

TURCOMP

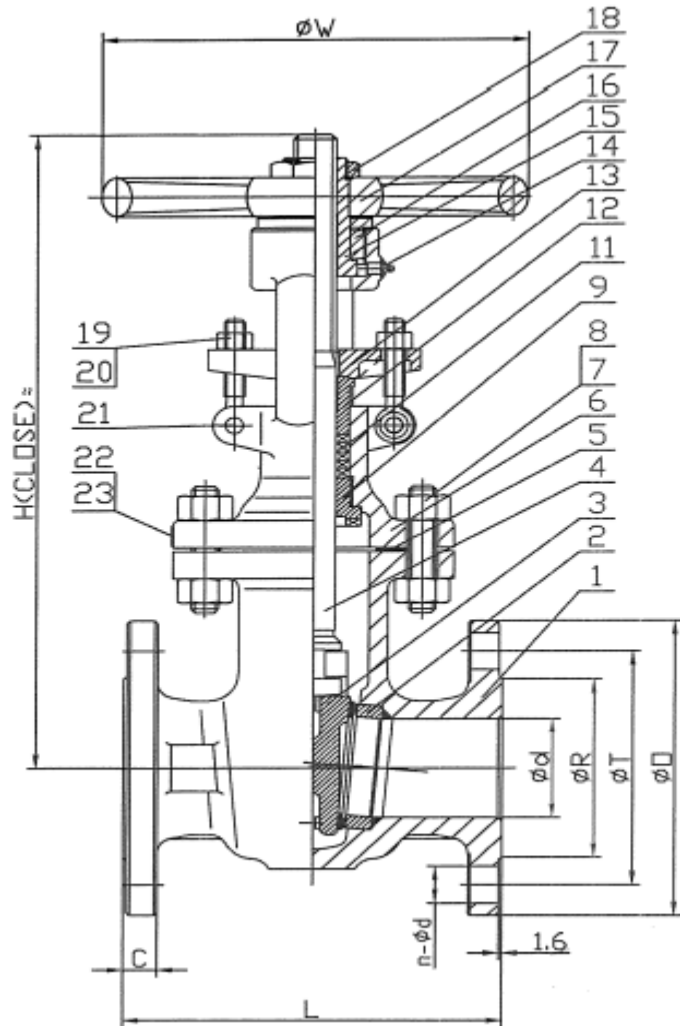

No.	Part Name	Material
1	Body	ASTM A216 GR. WCB
2	Seat Ring	ASTM A105 + STL #6
3	Wedge	ASTM A216 GR. WCB + CR13
4	Stem	ASTM A182 GR F6a
5	Gasket	SS304 + GRAPHITE
6	Bonnet	ASTM A216 GR.WCB
7	Nut	ASTM A194 GR.2H
8	Stud	ASTM A193 GR.B7
9	Back Seat	ASTM A276 TYPE 410
11	Packing	GRAPHITE
12	Gland	ASTM A276 TYPE 410
13	Gland Flange	ASTM A216 GR.WCB
14	Grease Fitting	CARBON STEEL
15	Stem Nut	ASTM A439 GR.D-2
16	Retaining Nut	ASTM A29 TYPE 1025
17	Handwheel	DUCTILE IRON
18	Handwheel Nut	ASTM A29 TYPE 1025
19	Eye Bolt	ASTM A193 GR.B7
20	Nut	ASTM A194 GR.2H
21	Pin	ASTM A29 TYPE 1025
22	Nameplate	SS316
23	Rivet	SS316

DIM NPS	Φd	ΦR	ΦT	ΦD	$n-\Phi d$	C	L	H	W	W(KG)
	2	51	92	120.5	152	4- $\Phi 19$	16	178	311	200
3	76	127	152.5	190	4- $\Phi 19$	19	203	368	250	36
4	102	157	190.5	229	8- $\Phi 19$	24	229	434	250	53
6	152	216	241.5	279	8- $\Phi 22$	26	267	581	300	85
8	203	270	298.5	343	8- $\Phi 22$	29	292	729	350	136
10	253	324	362	406	12- $\Phi 26$	31	330	864	400	200