

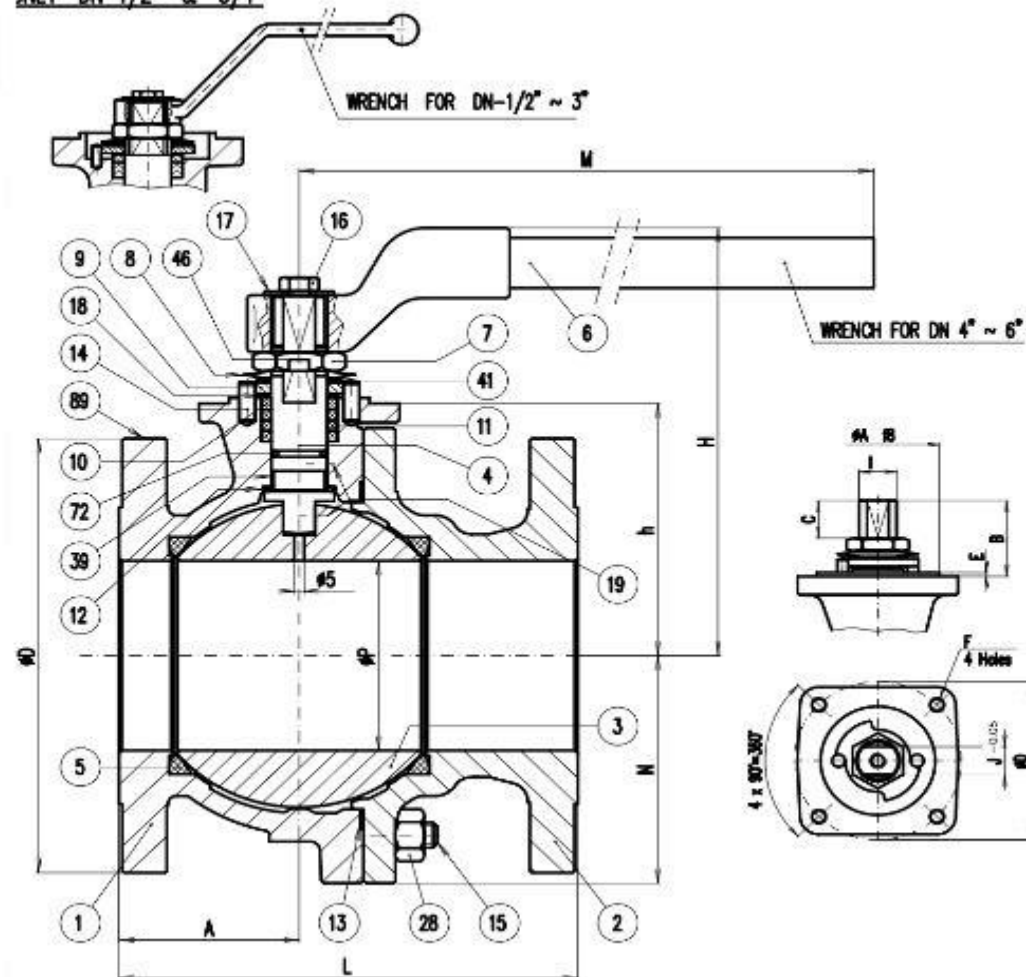

TURCOMP

ONLY DN-1/2" & 3/4"



	2	PLASTIC CAP	PLASTIC
89	1	IDENTIFICATION PLATE	STAINLESS ST.
72	1	*O" RING	FKM
46	1	LOCKING WASHER	AISI 304
41	1	SPACER (DN 40 ~ DN 150)	CARBON STEEL
39	1	STEM BUSHING	STANSIT
28	--	NUT (DN-3/4" ~ DN-6")	A 194 Gr. 2HM
19	2	ANTISTATIC DEVICE	STAINLESS ST.
18	1	THRUST WASHER	25% G.F. + PTFE
17	1	WASHER	ZINC PLATED CARBON STEEL
16	1	BOLT	DIN-933 5.6 ZINC PLATED
15	--	STUD (DN-1/2" BOLT)	A 193 Gr. B7M
14	--	STOP PIN	CARBON ST.
13	1	BODY CONNECTOR SEAL	AISI 316L + PTFE+ GRAPHITE
12	1	STEM THRUST SEAL	25% G.F. + PTFE
11	--	GLAND PACKING	GRAPHITE
10	1	GLAND	AISI 303
9	1	STOP PLATE	CARBON STEEL
8	2	DISK SPRING	CARBON STEEL
7	1	GLAND NUT	ZINC PLATED CARBON STEEL
6	1	WRENCH	NODULAR IRON
5	2	SEAT RING	PTFE
4	1	STEM	A 479 Tp.316
3	1	BALL	SEE "NOTE 1"
2	1	BODY CONNECTOR	A 216 Gr. WCB (C ≤ 0.25%)
1	1	BODY	A 216 Gr. WCB (C ≤ 0.25%)