

Automatic Swing door Operator

SD3108

Product manual

△Notes: please keep the manual properly for reference. Do carefully read this manual before use.

Safety Warning!

Please read carefully the instructions before installing the door operator, we do not take responsibility for the loss or damage due to the improper use disobeying the following cautions.

- △ **Do use the power conforming to the regulations!** Or otherwise, it may result in the damage of electronic component of partial circuit of machine.
- △ **Maintain the reliable grounding!** The enclosure of automatic door operator shall be made of metal material which is the sound electrical conductor. The grounding of automatic door operator must be well done, especially the metal door body on operator, as the conductor, must be reliably grounded.
- △ **Prevent vapor from intrusion!** The automatic door operator is inbuilt with the complicated and precise electronic components to prevent from vapor. The machine enclosure is unsealed for maintaining the automatic door operator.
- △ **Prohibit rapidly opening and closing automatic door by hand or rudely!** No matter on operation or power failure, prohibit rapidly opening and closing automatic door by hand or rudely to avoid the mechanical damage due to overload of automatic door!
- △ **The safety beam detector is highly recommended to avoid the probability of collision with pedestrian!** If you haven't the safety beam detector installed, You might be touched in the door operation area. So please use the safety beam detector where there are elder and children, and please also lower the opening/closing speed with the longer hold-opening times.
- △ The safety beam detector is highly recommended to avoid the probability for hands to be nipped by the closing door. Do not worry if you haven't the safety beam detector installed, because the door operator gives the buffer action and moves very slowly when the door closes to the 7-12° angle, please also adjust the inching latching force to a small range for the 100% safety for your children.
- △ **The person unauthorized by the company shall not repair or modify the spare part! If any problem of automatic door operator is found, the automatic door operator shall not be directly repaired without permission! Any modification to the automatic door operator may result in the serious consequences!**

Content

1. Product Overview

1.1 Product Procedure

1.2 LED Indicator

1.3 Main Parameters

2. Installation

2.1 Installation Notice

2.2 Want your door to be

2.3 Installation measurement and mode

3. Wiring diagram

4. Debugging

4.1 Control programmer debugging

4.2 Remote control function debugging and management

5. Trouble shooting

1.Product Overview

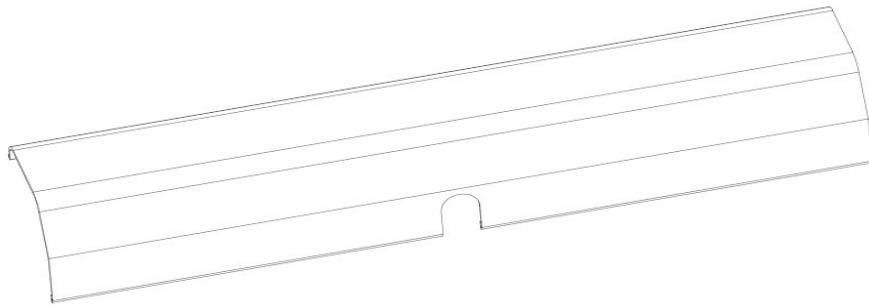
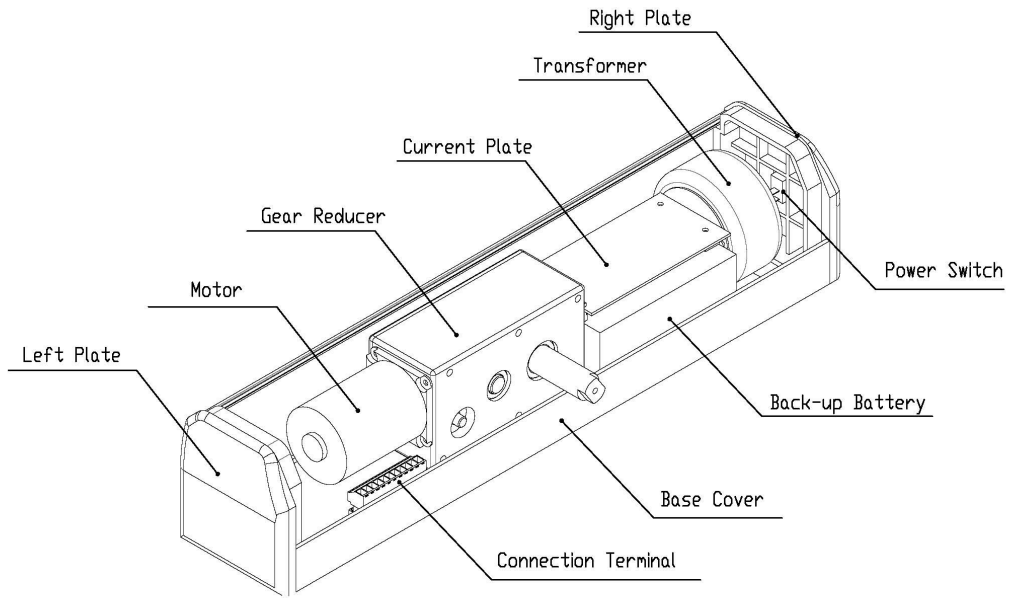

Cover

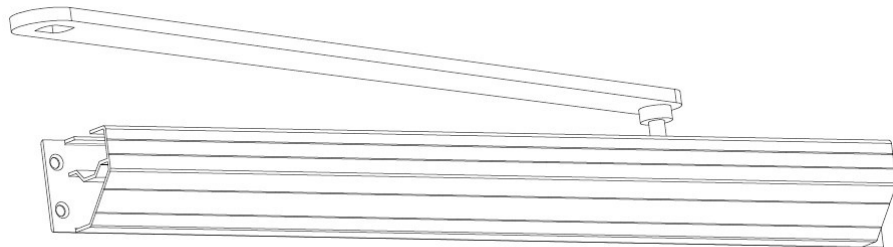

Sliding arm

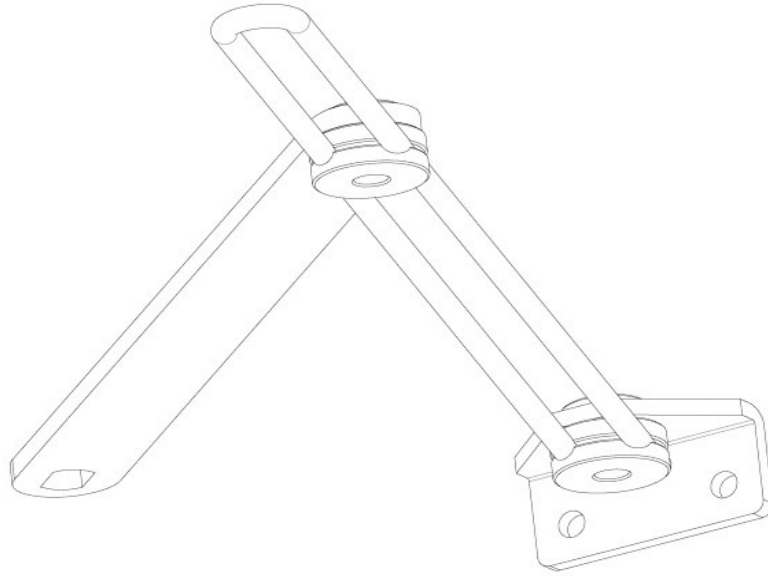

Articulated arm

Please carefully read this instruction for better use this equipment.

The automatic swing door operator SD3108 is intelligent equipment controlled by the microcomputer, enjoys excellent capability and strong function.

- △ Surface mounting**
- △ Push-Go: Automatic activation by pushing or pulling door panel**
- △ Operators can be integrated with security systems, card readers, etc.**
- △ Quiet and aesthetically pleasing**
- △ Electric strike integration**
- △ Reversing and obstruction sensing**
- △ Efficient and cost-effective**
- △ Battery Convenience Mode-operator can be activated by battery power for continuous operation in the event of a power failure.**

△ Easily adjustable opening & closing speeds

△ Manual operation in case of power failure

1.1 Operation Procedure

Activated by the signals from external control device, unlock → open → buffer action & stop → hold-open → close → buffer action & stop → lock and seal.

1.2 LED Indicator

Green lighting LED: Operation status

Red LED lighting LED: The operator is supplied with power

1.3 Main performance parameter

Applicable for single leaf swing door: Max weight 120Kg (264 lb) & Max width 1200mm (48 ")

Installation method: surface mounting (external)

Opening angle: 60° ~120° adjustable

Speed of opening/closing: 30-100M/S adjustable

Hold open time: 0-120S adjustable

Working noise: ≤60db

Power supply: 220V ± 10% 50~60HZ

Safety system: the automatic protection device against overheating, overvoltage, over current and obstacle-encountering

Rated power: 45W

Static power: 4.8W

Output voltage of power: DC24-12V for the optional accessories, such as body sensor; access device, safety beam, electric strike and others.

2 Installation

2.1 Installation Notice

◆ The operator is available both for the left handing and right handing door (can mounted on the hinge side or not the opposite hinge side.)
Articulated arm and sliding arm both can be used to this operator.

◆ Door leaf max weight and width: Please refer to the max limit of the door application; overweight will affect the capacity of the operator. (See below diagram)

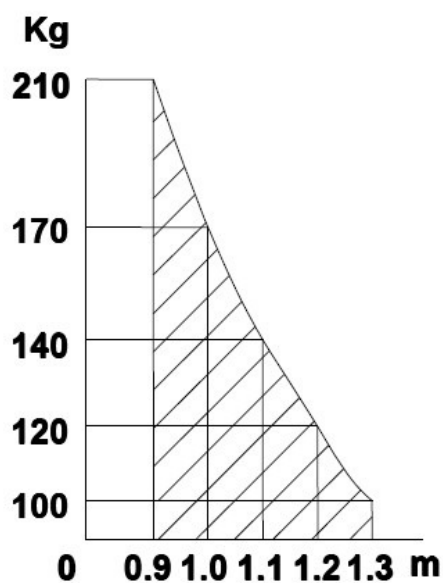

◆ Installation measurement: The operator must be installed exactly as the measurements stipulated by the instruction manual, the improper installation will decrease the operation of the operator, even cause malfunction and damage.

◆ When the operator is supplied with power, the driving axis will rotate 360°. This is normal action, when it is fixed onto the door leaf, it will perform normally.

2.2 What your door to be

- ◆ Become inductive automatic door by connecting sensor inductor.
- ◆ Become identifying automatic door by connecting code remote control or card reader and other door access control system.
- ◆ Become apartment automatic door by connecting building intercom system.
- ◆ Become long-distance wiring control automatic door by connecting push button on the table or wall.
- ◆ Automatic open/close set as required when on fire by connecting to fire alarm equipment.
- ◆ Automatic close on pilferage by connecting to theft alarm equipment.
- ◆ Become double leaf automatic doors by simultaneous performance of 2 operators.

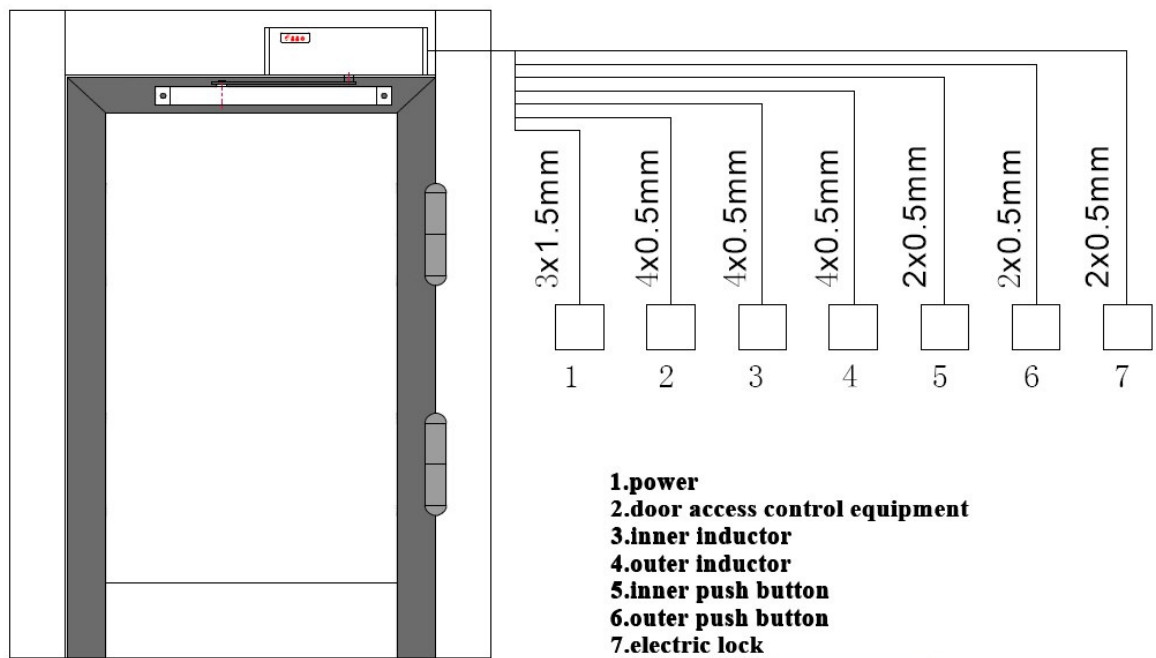

2.3 Installation measurement and mode (The measurement is in millimeter)

- A. Sliding arm model

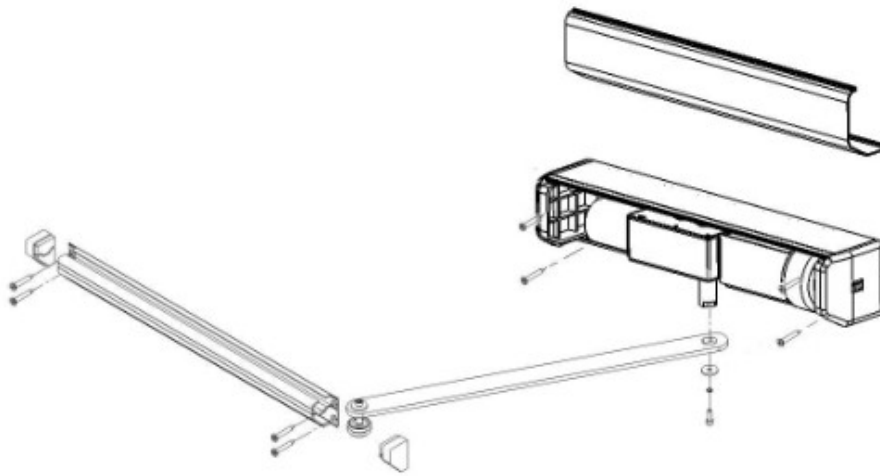

Sliding arm model, left outward opening installation

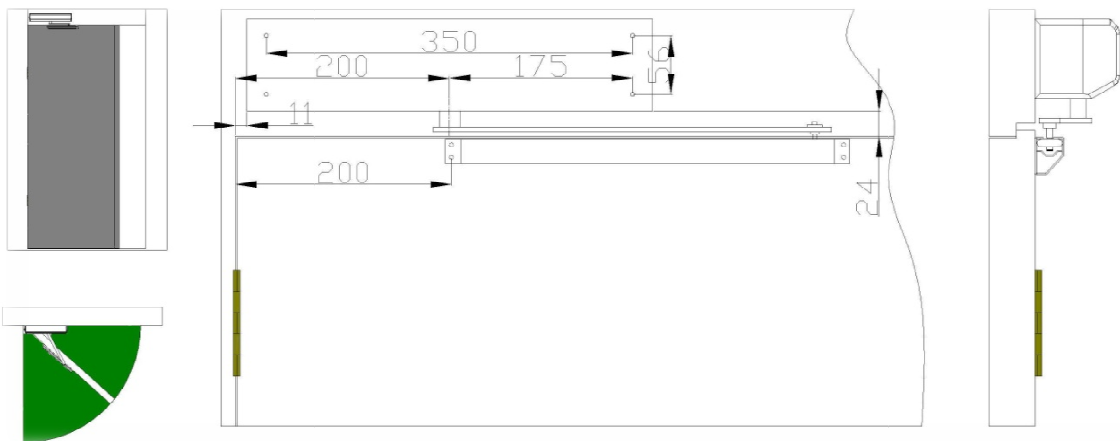

Sliding arm model, right outward opening installation

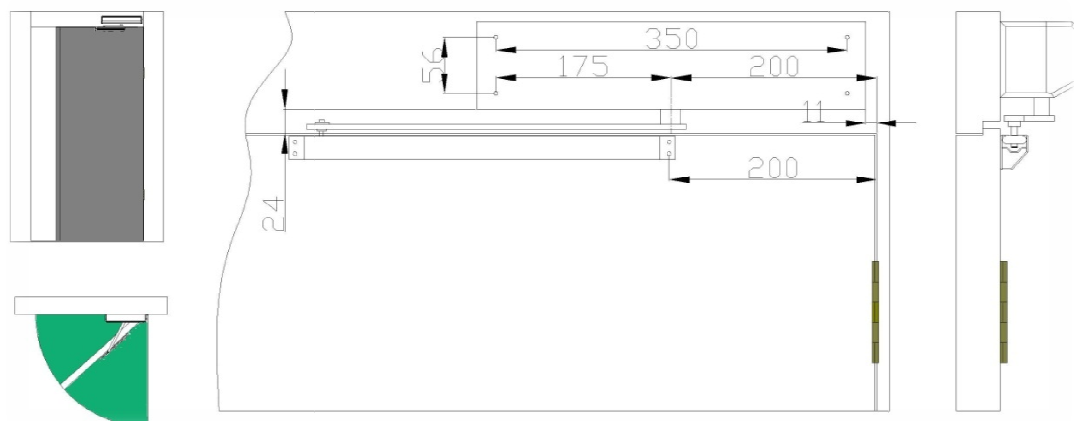

- **B. Articulated arm model**

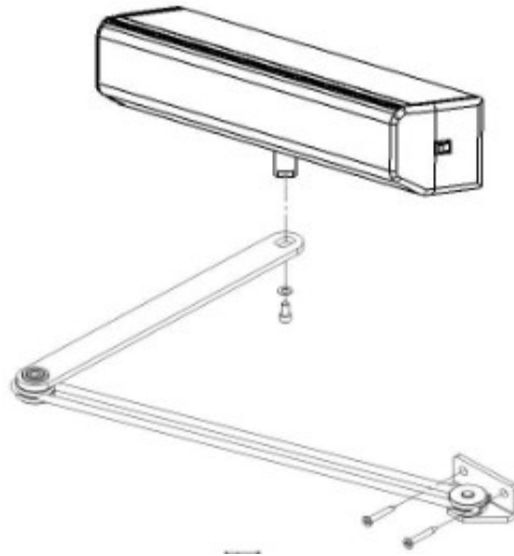

Articulated arm model, left handing, outward opening installation

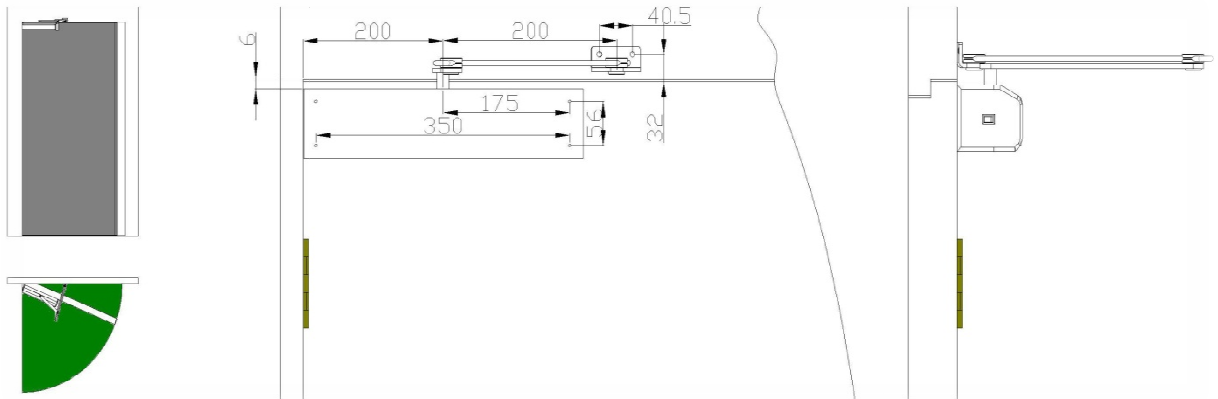

Articulated arm model, right handing, inward opening installation

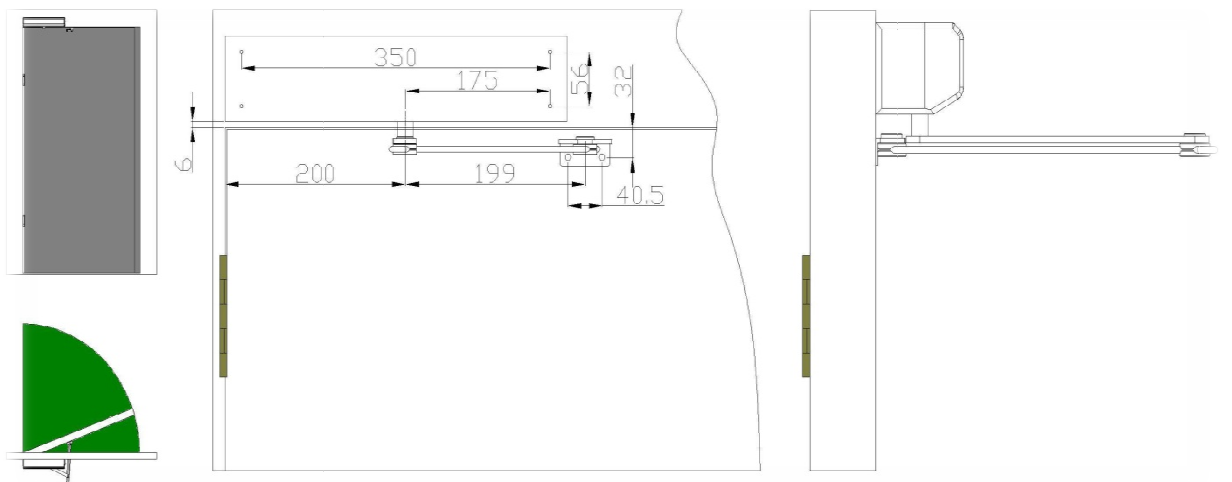

2.3.1 Supplement Notice

It is suggested to fix the driving arm to the door frame vertically, or fix at a 15° angle with the vertical line. When the door leaf and door frame are on the same plane;

If the door is fixed at the different depth of the door frame, it should be noticed that for articulated arm model, the linkage arm should be lengthened; for sliding arm model, for sliding rail may be not long enough.

Note: Figure 4, the door leaf depth shall be less than 80mm for the normal existing linkage arm; Figure 5, the linkage arm shall be specially tailored longer if the door leaf depth is more than 80mm. (Please inquire your distributor for the special longer linkage arm)

Articulated arm correct angle

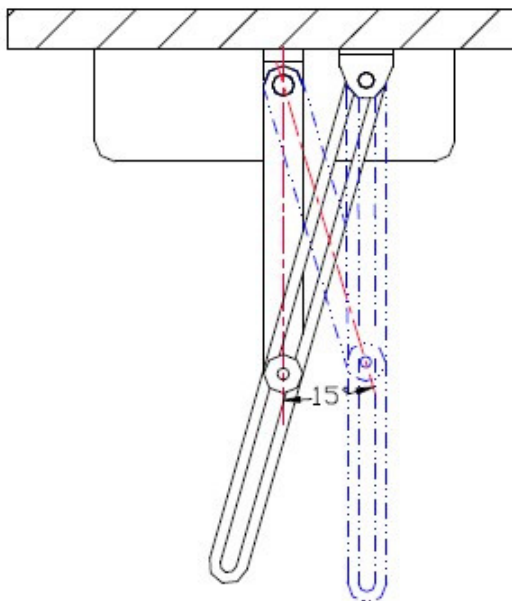

Figure 1

Utmost angle for sliding arm model

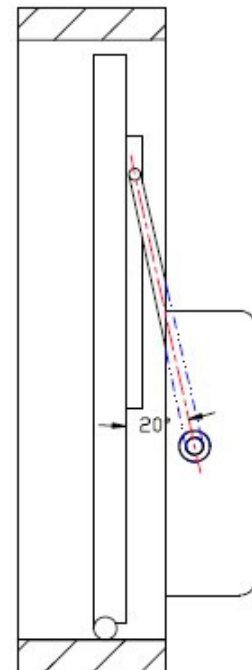

Figure 2

On the edge of inner frame

In the middle of frame

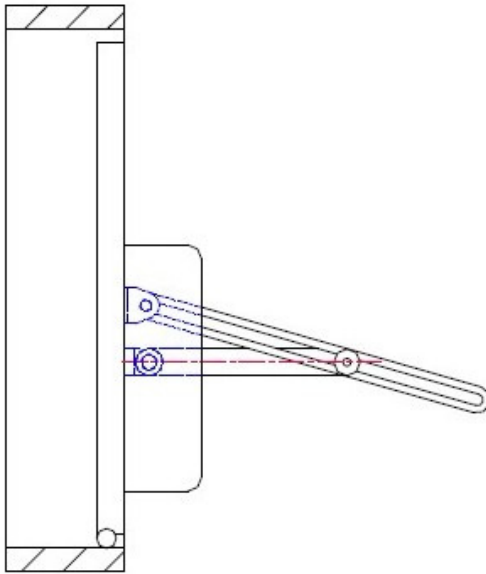

Figure 3

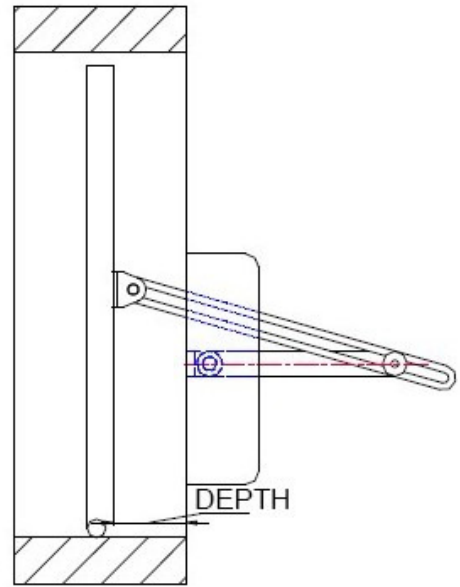

Figure 4

On the edge of outer frame

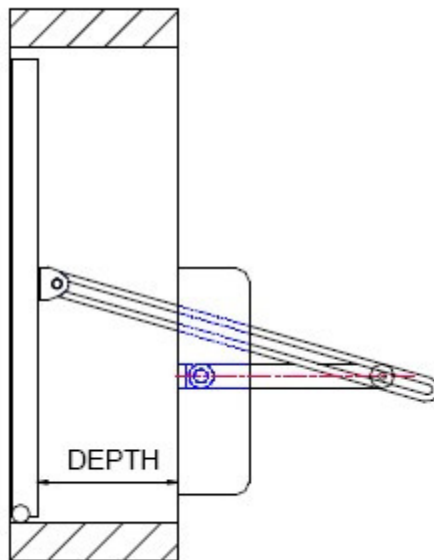

Figure 5

Notes to installation

Do install in accordance with the dimension stated in this manual; the incorrect installation will directly affect the machine operation even cause failure damaging the machine.

When the equipment is being installed, do tighten reliably to prevent the machine from loosening to result in the incorrect identification of door and cause vibration; meanwhile, it will also influence the door operation and service life of machine.

The body sensor can induce the movement of human body only. while, the other types of sensor can induce all the moving objects. As long as the object moves, the sensor will react; therefore, the automatic door operator will be triggered to operate. All the other moving objects installed in the door body shall avoid the detection scope.

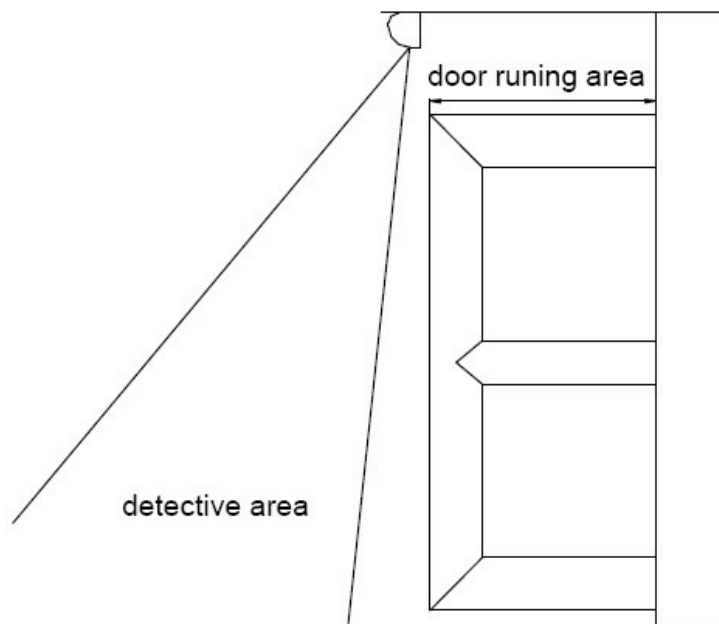

3. Wiring Diagram

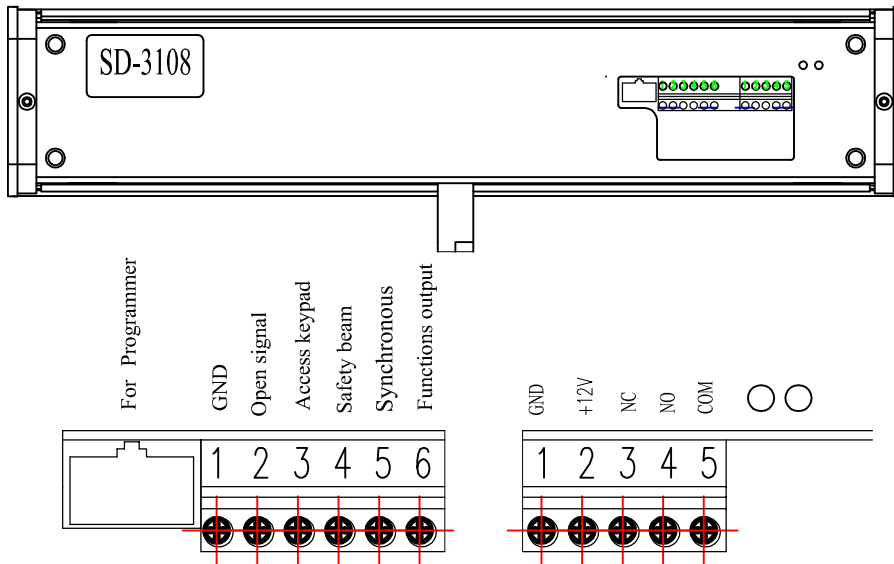

Push button wiring diagram

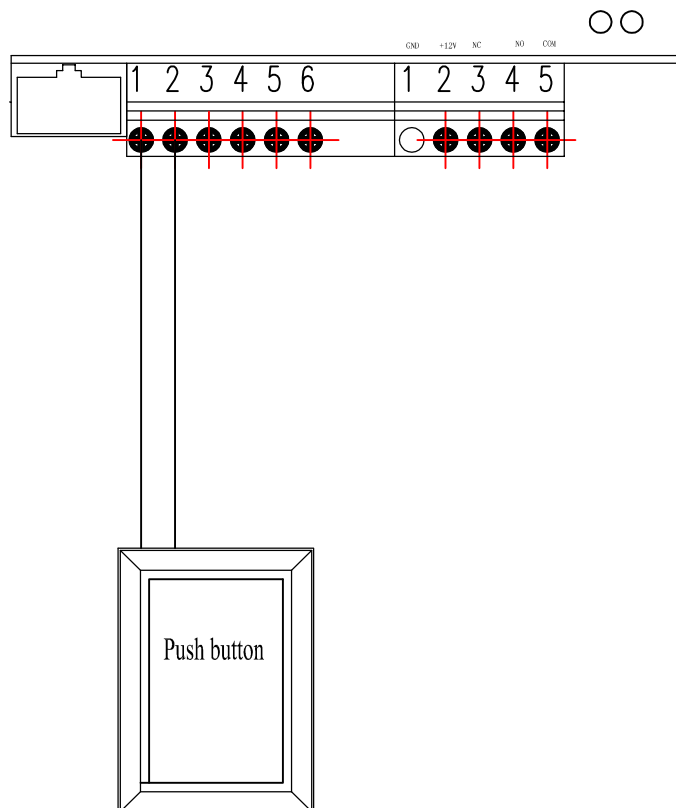

Safety beam wiring diagram

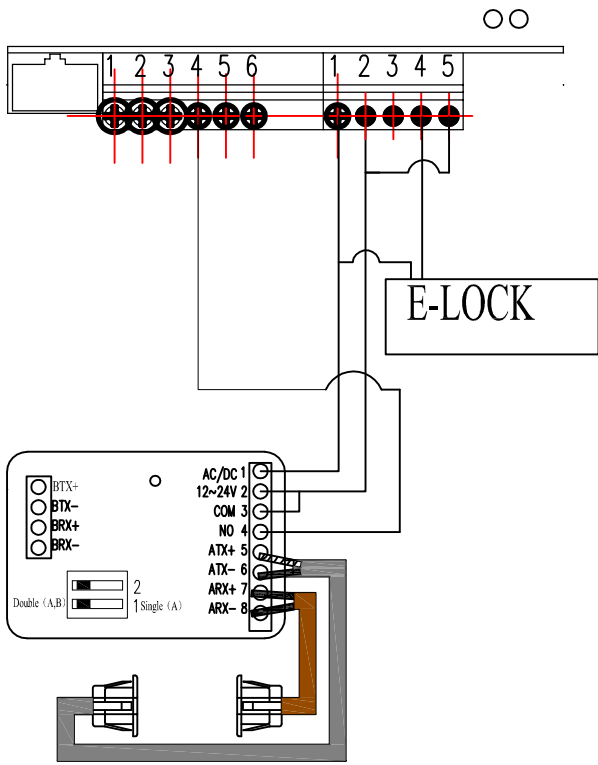

Foot sensor wiring diagram

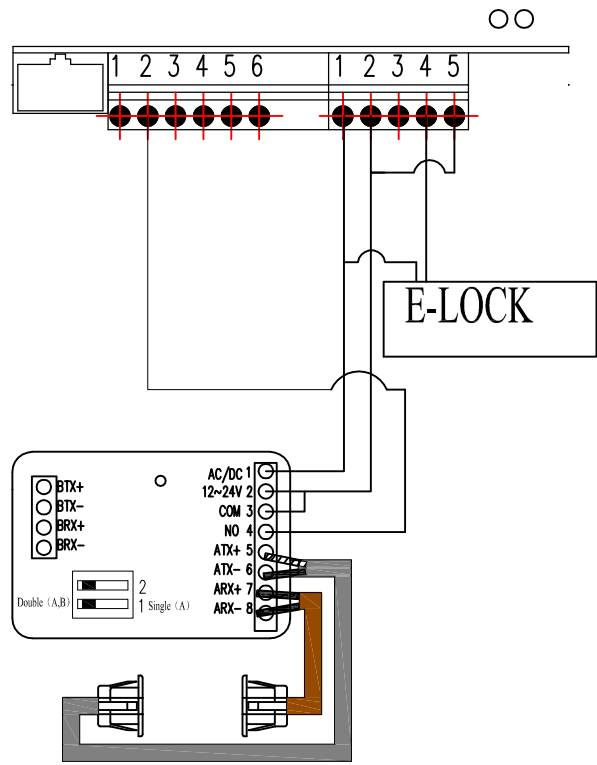

Body sensor wiring diagram

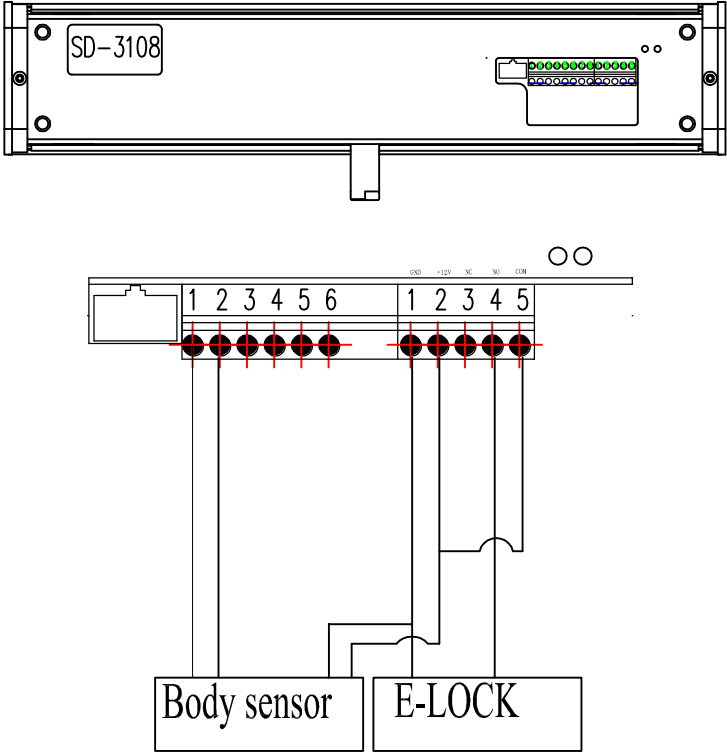

Double doors wiring diagram

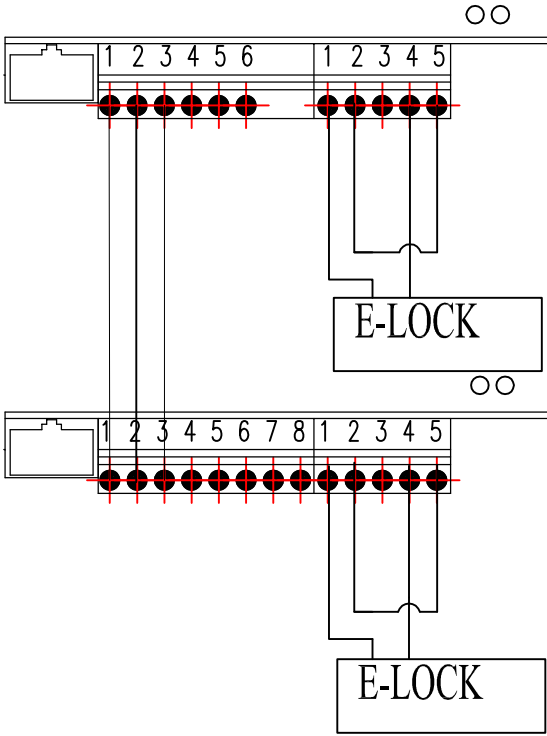

Fingerprint machine wiring diagram

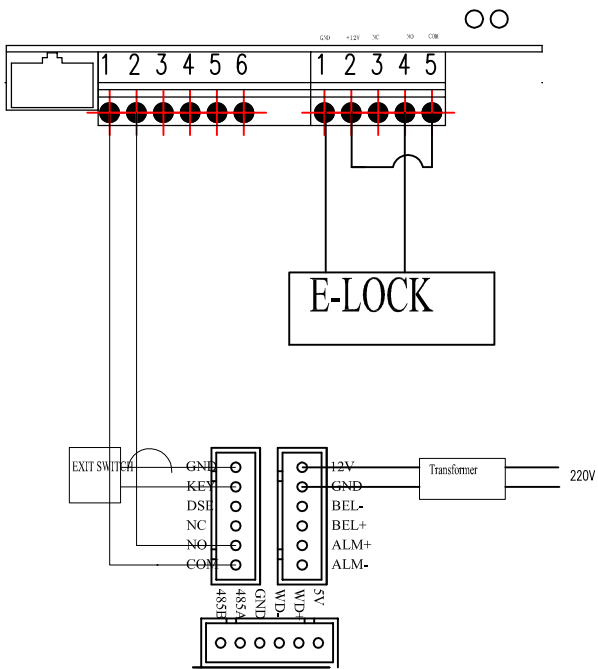

Touch sensor wiring diagram

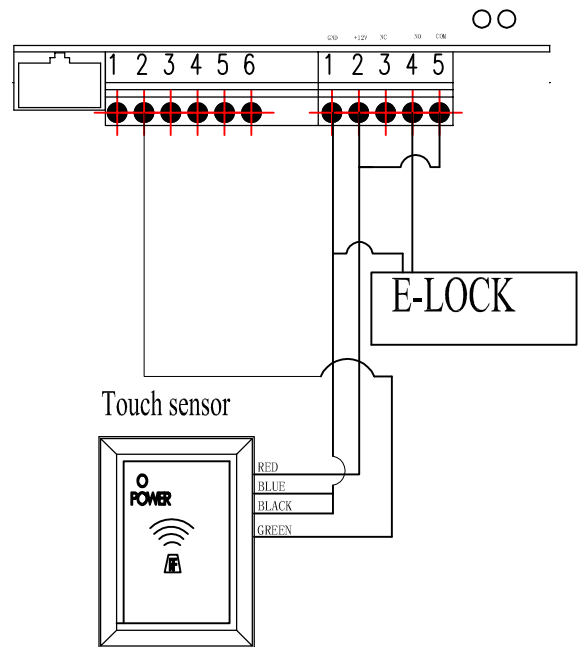

Access keypad wiring diagram

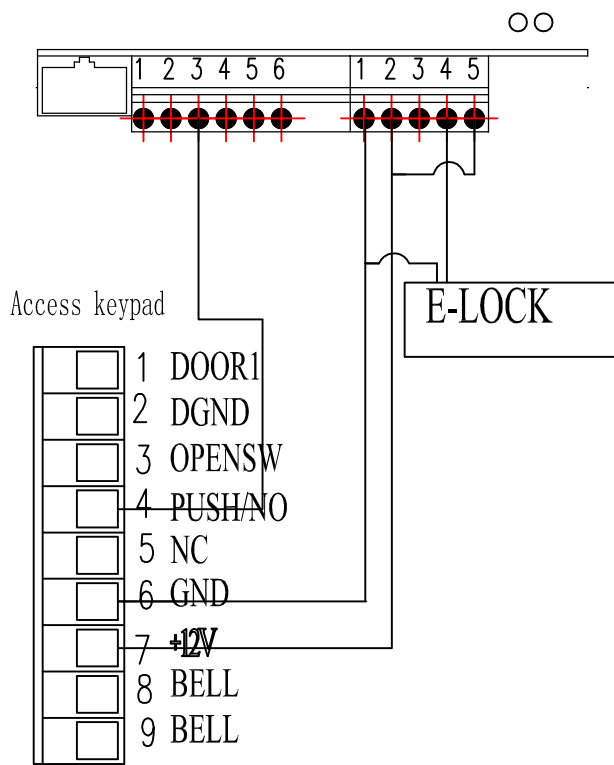

Access keypad & E-lock & External power

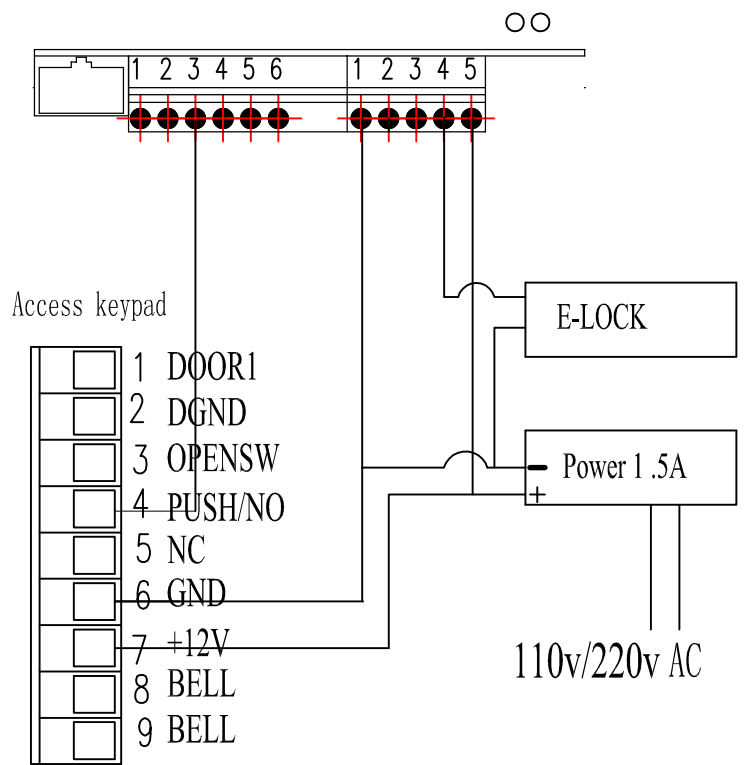

Access keypad & E-lock & External power

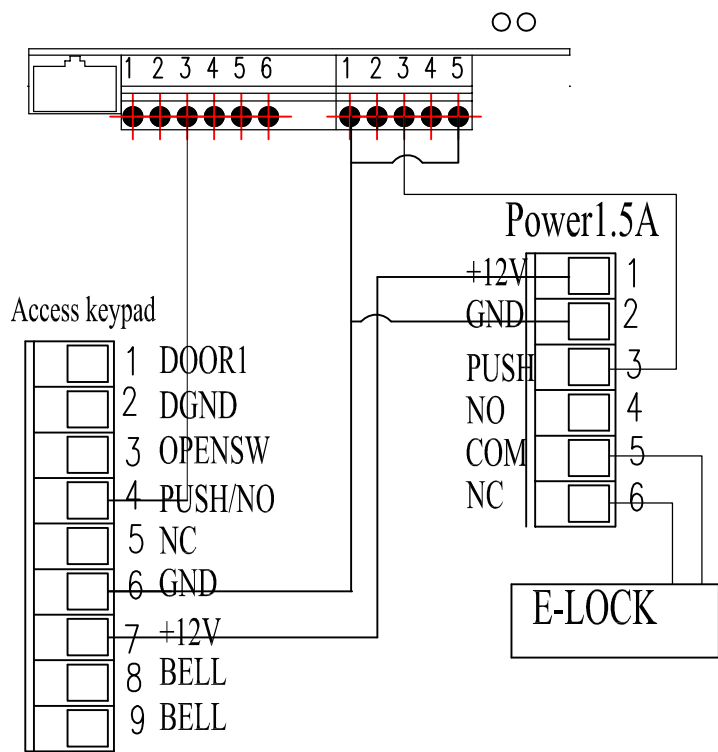

Access keypad & E-lock & External power

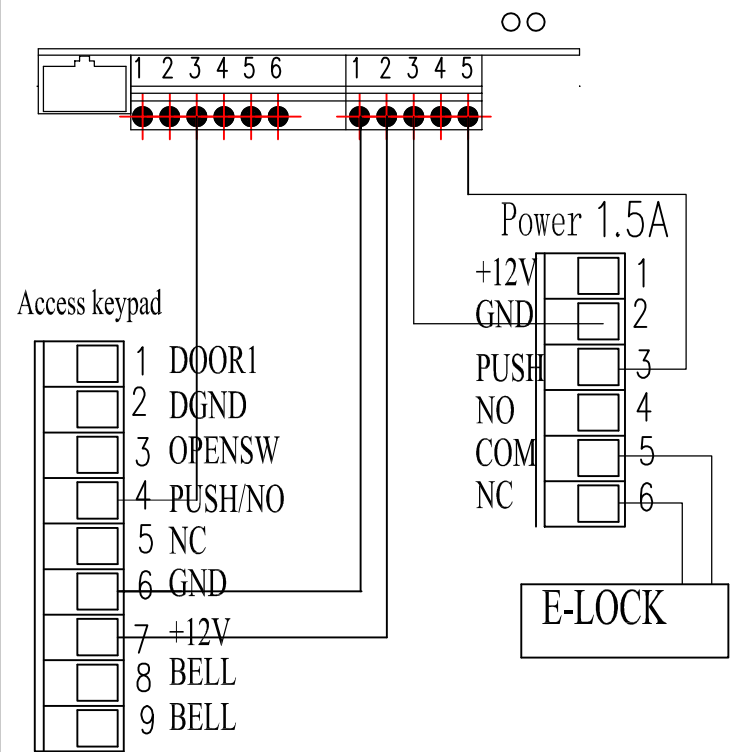

4. Debugging

4.1 Control programmer debugging

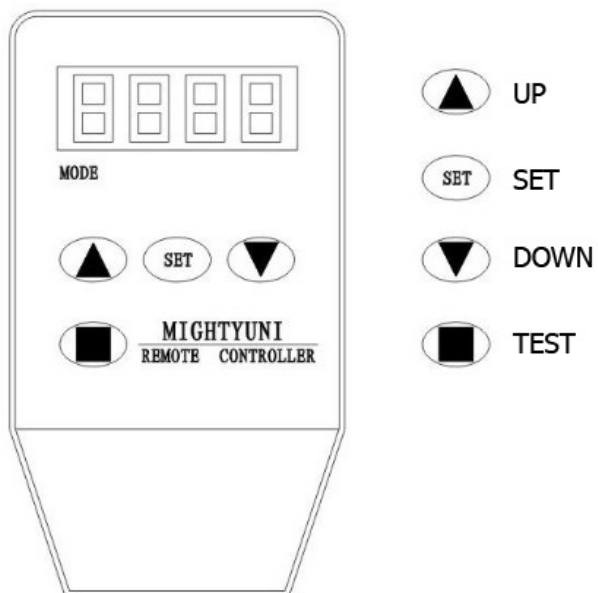

Notes:

Do not inset or draw out the debugger with power; do after power disconnection.

Debugger operation:

The debugger is connected to the telecommunication interface of controller to display XXXX-XXXXXXX characters; enter the menu of parameter of automatic door by pressing SET and adjust UP or DOWN; open the door by TEST.

If no pressing after 30s, back to the menu displaying XXXX-XXXXXXX characters; When the S/N is being selected by SET, press UP/DOWN to adjust the number scope and SET to save.

Operation Procedure

Activated by the signals from external control device, unlock → open → damping action & stop → hold-open → close → damping action & stop → lock and seal.

Debugging

S/N	Value scope	Initial value	Function description
1	10-100	65	Opening speed `
2	10-100	55	Closing speed
3	1-10	2	Damping opening speed
4	1-10	2	Damping closing speed
5	1-60	20	Damping opening distance
6	1-60	20	Damping closing distance

7	0-120	2	Hold-on open time
8	0-3	1	Delay open time
9	0-1	1	Left and right directions of door opening
A	0-1	1	Fire alarm signal to open/close door
B	30-200	90	Opening/Closing angle
C	0-30	20	Locking force
D	0-60	20	Opening braking force
E	0-60	20	Closing braking force

Debugging Further introduction:

1. Opening speed, 10-100 adjustable
2. closing speed, 10-100 adjustable
3. The speed of damping opening, 1-10 adjustable
4. The speed of damping closing, 1-10 adjustable
5. Opening damping distance, 1-60 adjustable
6. Closing damping distance, 1-60 adjustable
7. The time from the door opening destination till the door begin to close, 0-120s adjustable
8. Delay-open time: delay opening time 0-3s adjustable, specially supply time for electro lock to lock or unlock which is helpful to avoid damage to drop bolt lock.
9. Opening direction (Left or Right)
 - A. Fire signal open/close: It is only used when connected with fire alarm system.
 - B. Opening angle adjust: 30-200 adjustable. The digital angle is not the door opening angle, but the driving axis turning angle; the door opening angle features different subject to the sliding arm or articulated arm. Users can adjust the digits referring to the real door opening angle.
 - C. Locking force 0-30: The force to open the door manually when the door is closing
 - D. The braking force when the door being fully opened, 0-60 adjustable
 - E. The braking force when the door being fully closed, 0-60 adjustable

4.2 Remote control function debugging and management

One remote control can control a lot of operators, and one operator can be controlled by 15 remote controls utmost, but the operator only accept authorized remote control, you do not worry that your neighbor's remote control can open your door. You need to manage the remote control when adding or canceling them:

Matching the code: authorize the remote control

Press And Release The code-matching white button S1 on power supply (see above pictures), the LED D1 on the circuit panel will light shortly, then press and release any key-press on the remote control (do not keep pressing), the LED D1 on the circuit panel will light shortly again, and then the code matching is finished; if the LED doesn't light, you shall restart the above operation; If you need to add more remote control, Just Repeat the above procedure.

Clear all the code authorization of remote control

Keep pressing the code -matching button for about 10 seconds until the LED extinguish, all the authorized code will be cleared.



Inductor and other equipment debugging

Please refer to the instruction of inductor and other equipment.

Troubles Shooting

Trouble	Reason	Solution
No indicator LED lights on power supply	Power failure	<ul style="list-style-type: none"> • Open the cover of machine body; check if the fuse of 220V/110V power is burned down. • Open the outer crust and check if happens 220V or 110V power fuse blowout.
The remote control doesn't work	Failure of remote control	<ul style="list-style-type: none"> • Connect the port "door opening signal" with the public port "GND" by the wire; if the side of door opening is not allowed, check the machine power; if the signal of door opening is accepted, further check as per the following steps: <ol style="list-style-type: none"> 1. If the indication light is on when the key of remote control is pressed; if out, replace with the same kind of battery after opening the rear cover. 2. Re-learn the code of remote code; if it still doesn't work, check if the receiver or remote control doesn't work
Door knock	<ol style="list-style-type: none"> 1. The brake doesn't work well; 2. Too small of distance of damping speed 3. Too fast door closing 	<ul style="list-style-type: none"> • Turn up the braking force (Option E) • Increase the damping close distance (Option 6) • Slow down the speed of door closing
Door open not in place	<ol style="list-style-type: none"> 1. The angle is not well adjusted; 2. The signal of door opening is sent before the powering on and resetting; 	<ul style="list-style-type: none"> • Adjust the angle of door opening (Option B) • Reclose the power; close the door and then power on; send the signal of door opening after 60s
Door in unclosed state	<ol style="list-style-type: none"> 1. The angle to be 	<ul style="list-style-type: none"> • Decrease the angle of door

	<p>adjusted too large</p> <ol style="list-style-type: none">2. The signal of door opening is sent before the powering on and resetting;3. Failure of external signal	<p>opening (Option B)</p> <ul style="list-style-type: none">• Reclose the power, close the door and power on once again.• Remove the external signal
--	---	---