

# AUTOMATIC SWING DOOR

SPRING RETURN

DSW85

*Power open, spring close*

*Hand open, spring close*

*More safe , more stable*

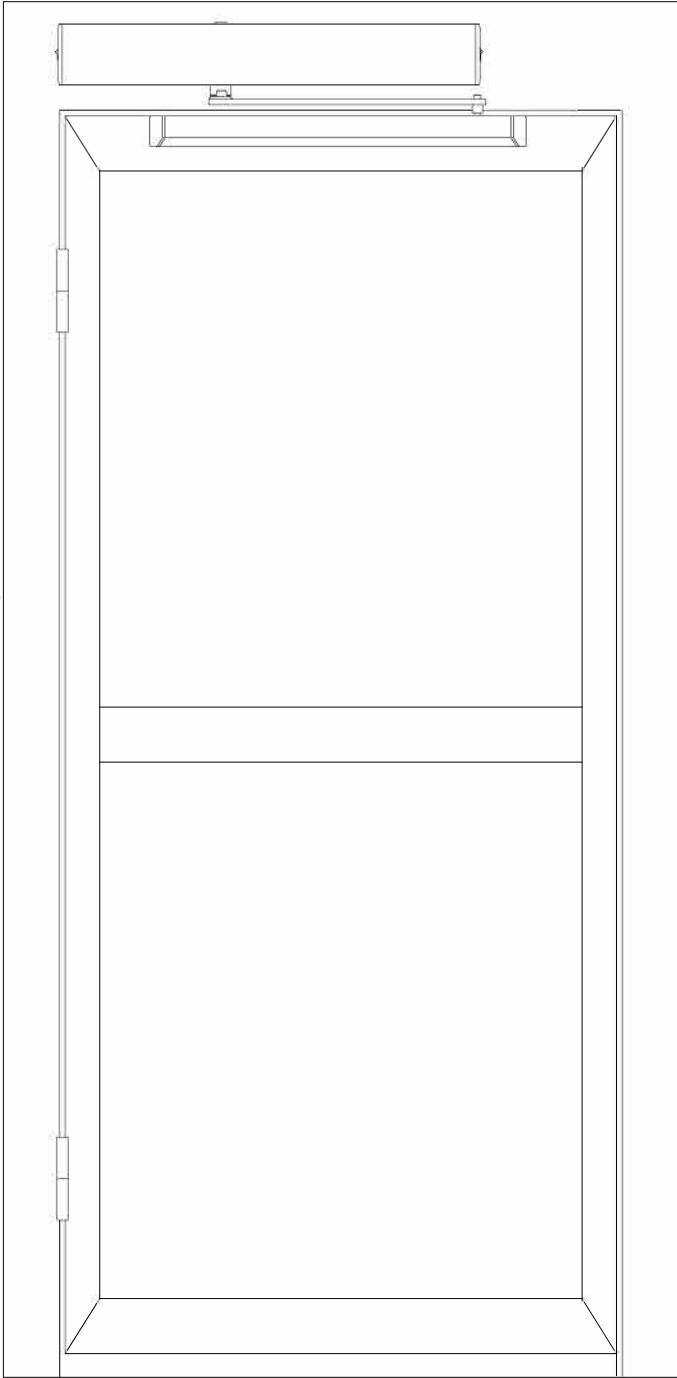

# CONTENTS

◆ Safety guide .....	01
◆ Technical data .....	02
◆ Components .....	03-04
◆ Installation .....	05-12
◆ Debugging .....	13-17

## ⚠ Warning

### **Beware of electric shock and fire**

- ★ During installation and adjustment, please follow this manual;
- ★ Don't allow to decompose, transform or repair the components;
- ★ Input supply power AC 220V, make sure the Ground wire is connected;
- ★ Whole process of the installation, the power must be disconnected.

### **Beware of electric injure and malfunction**

- ★ When the door is under working, don't cut off the power;
- ★ There is person or block in the door, don't turn on the power;
- ★ Power failed, you can open the door by hand, please take care of your finger;
- ★ If open by hand, please make sure the door is running in the right trajectory;
- ★ Don't allow to disassemble the gear box from motor, because the spring fly out may hit you.

*DC 24V output is for sensor ( please don't use other power for the sensor )*

### ⚠ Note:

Before installation, please read this manual carefully and fully understand it, then do the installation. ( If you didn't follow this manual, any problem happened will be responsible by yourself.)

## Chapter 2 Technical Data

### 1. Technical data

Supply power:	220 VAC $\pm$ 10%, 50/60Hz
Power consumption:	100W (max)
Drive unit:	24V DC Motor, spring closer
Anti-press device:	STD
Open angle:	80°-100°
Opening time (speed):	3-7Sec. (adjustable)
Closing time (speed):	3-7Sec. (adjustable)
Hold-open time:	0.5-30Sec. (adjustable)
Drive arm:	pull arm(inward open) / push arm(outward open)
Environment temperature:	-20°C-45°C
Relative humidity:	$\leq$ 85%

### 2. Door width and weight:

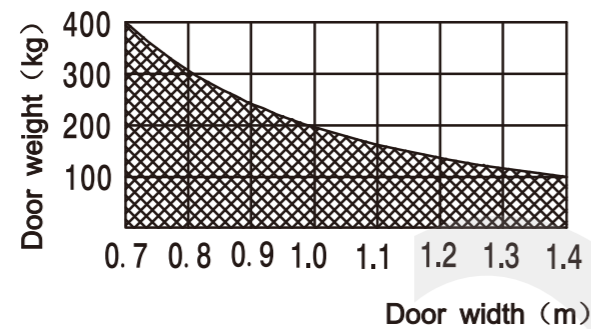

### 3. Product dimension (mm):

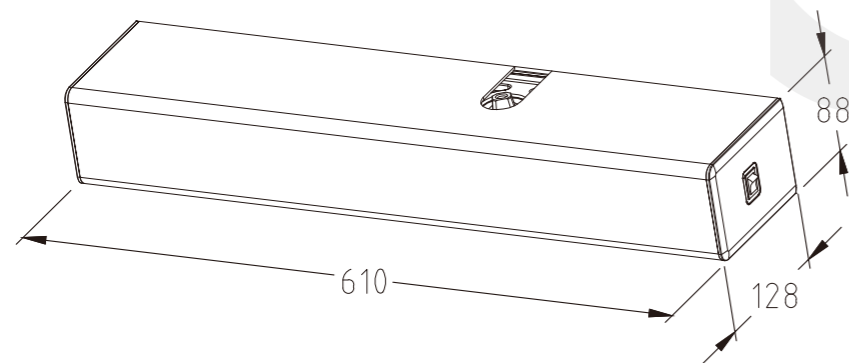

## Chapter 3 Components

### Description(1)

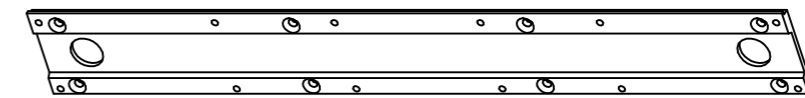

Base plate

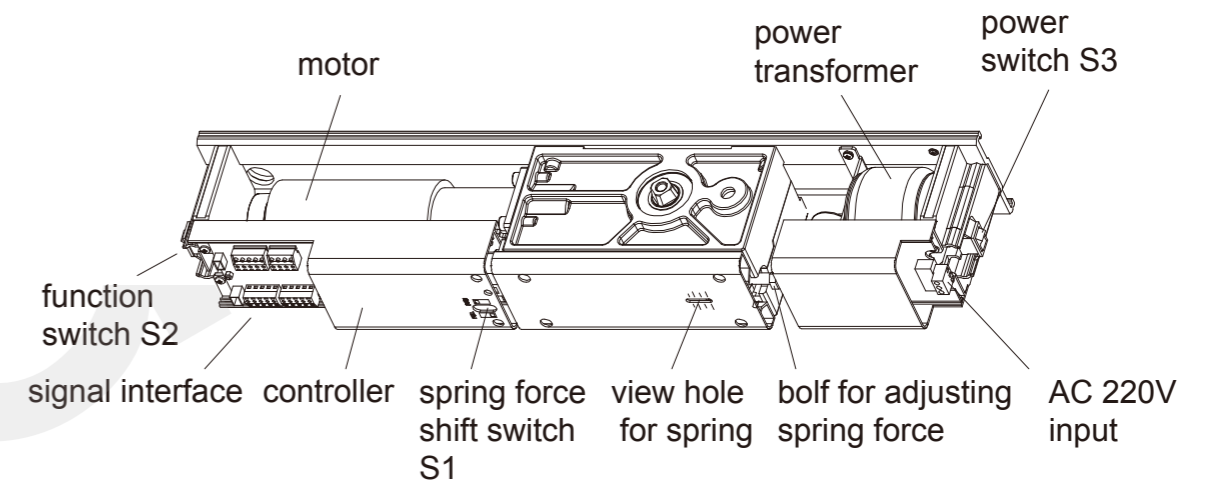

Drive device

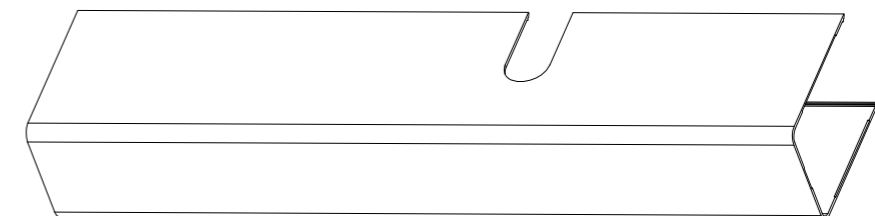

Cover

Description(2)

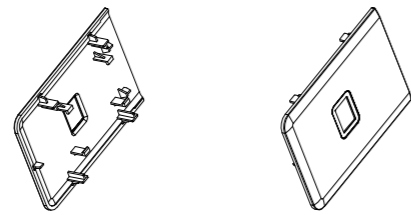

end caps (1 pair)

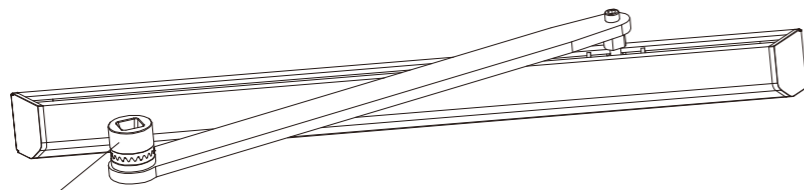

Spline housing

Pull arm (alternative with push arm)

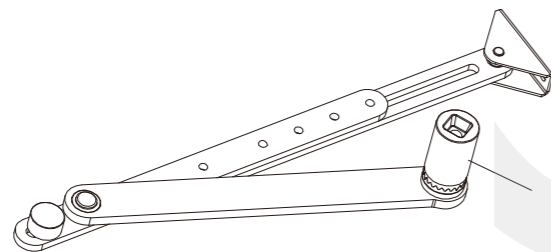

Extended Spline housing

Push arm (alternative with pull arm)

# Chapter 4 Installation

## 1. Set installation mode

Note: Find out the switch S1 on the drive device, choose installation mode according to the specific installation form (pull arm or push arm) (see figure on the right).

If choose wrong, the drive device can not work properly. Factory setting is installation with pull arm.

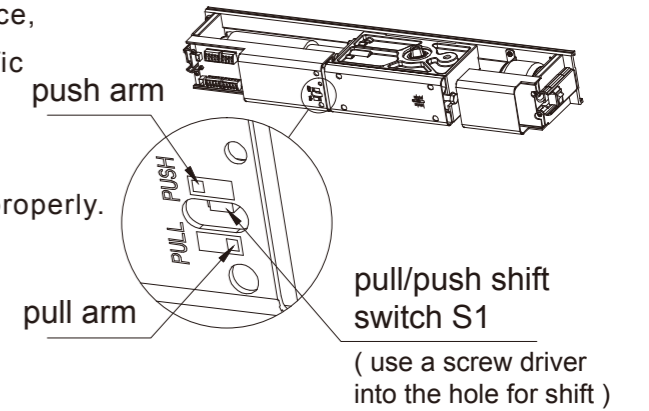

Application of pull arm mounting (for example, right mounting)  
Suitable for inward open doors (the drive is inside)  
Door leaf width min. 680mm.

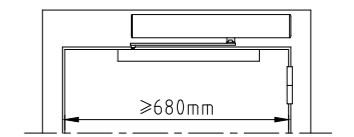

opening direction

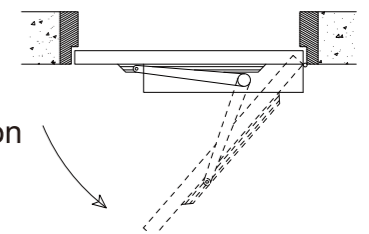

Application of push arm mounting (for example, right mounting)  
Suitable for outward open doors (the drive is inside)  
The depth between the door face and the opposite wall should be less than 180mm.

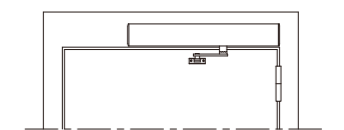

opening direction

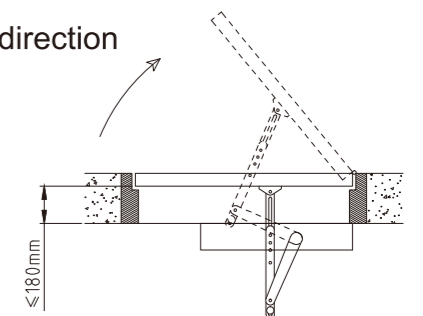

## 2. Installation with pull arm

### 1. Base plate and slide rail

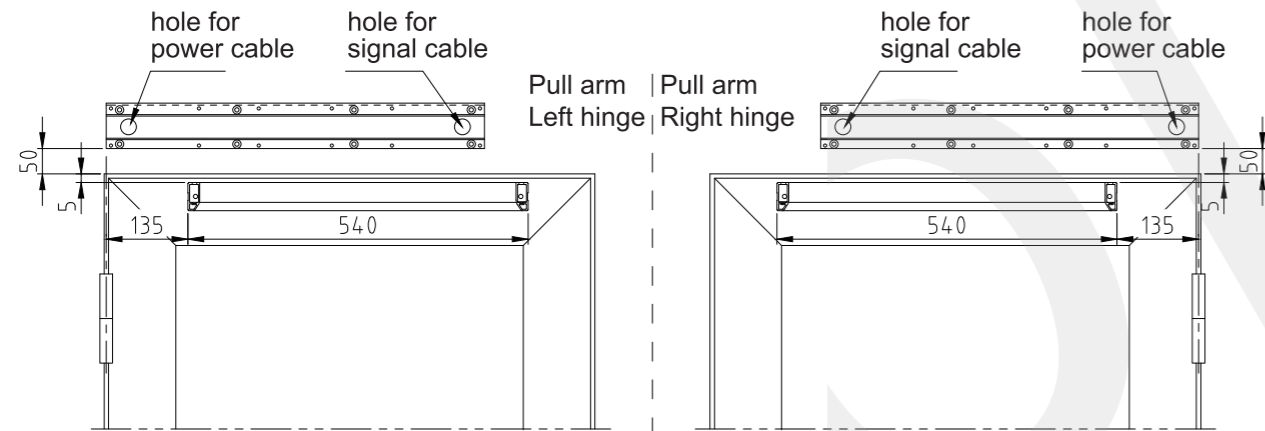
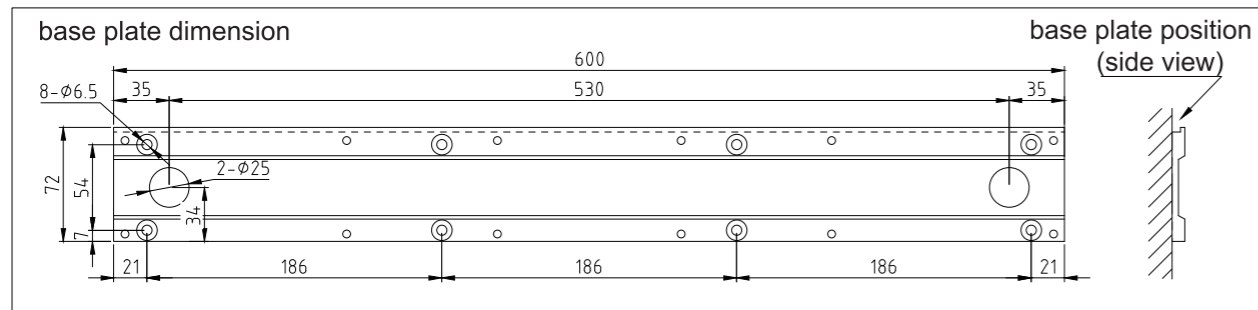

## 2. Drive device

Hang the drive device onto the base plate and tighten with 8pcs bolts M6x12.

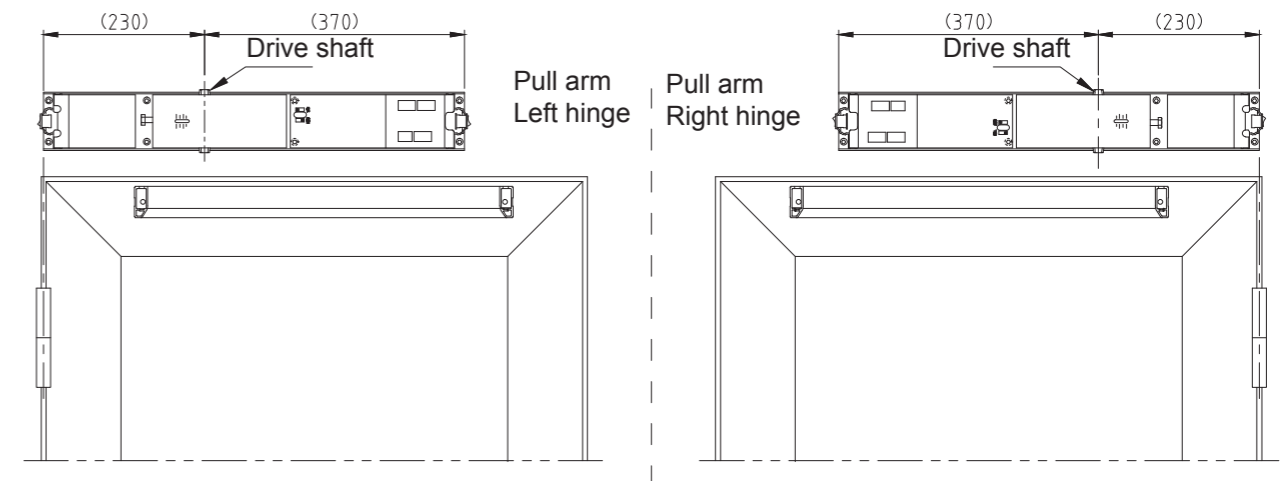
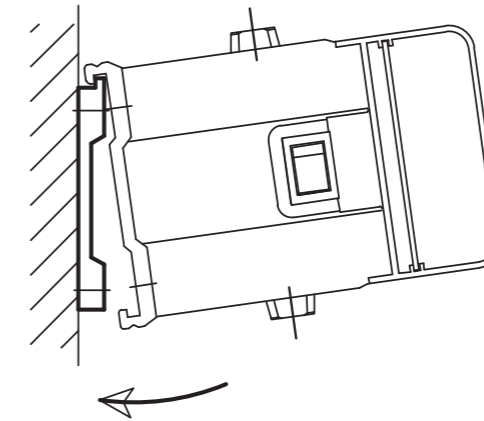

### 3. Install pull arm

Temporarily remove the slider on the pull arm;  
 Take the Right hinge assembly as an example, according to the diagram, assemble the spline housing, the pull arm and the drive shaft together (the end face needs to be completely fitted), and the pull arm (shown by the dashed line) must be in the range of 0~40, if not, rotate the spline housing 90° with respect to the drive shaft and test again until it meets the requirements.

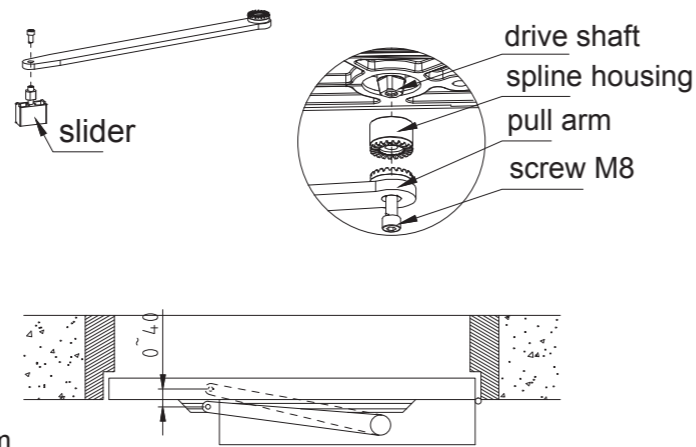

Fasten the M8 screws and tight torque is 15 N.m.  
 Finally, place the slider back into the slide rail and reinstall it with the pull arm.

The position of the stopper is adjusted according to the actual full opening Angle.  
 The full opening angle should be less than 100°, otherwise the spring reset mechanism in the drive device may not be able to drive the door back to closed.

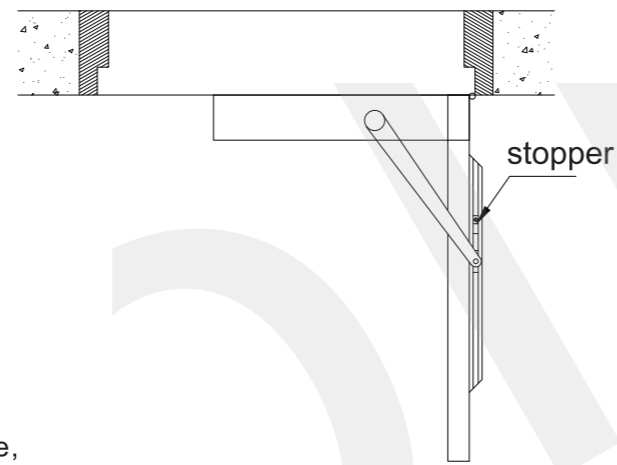

It can be tested by pushing the door to the max. angle in the state of power failure, try to let it go, and the door leaf should be able to close slowly by itself (if the door is rapidly closing without resistance, indicating that the setting of pull/push arm shift switch S1 is wrong, see P5 "setting of installation mode").

### 3. Installation with push arm

#### 1. Base plate and fixed seat of push arm

Base plate dimension is on P6 (base plate and slide rail installation)

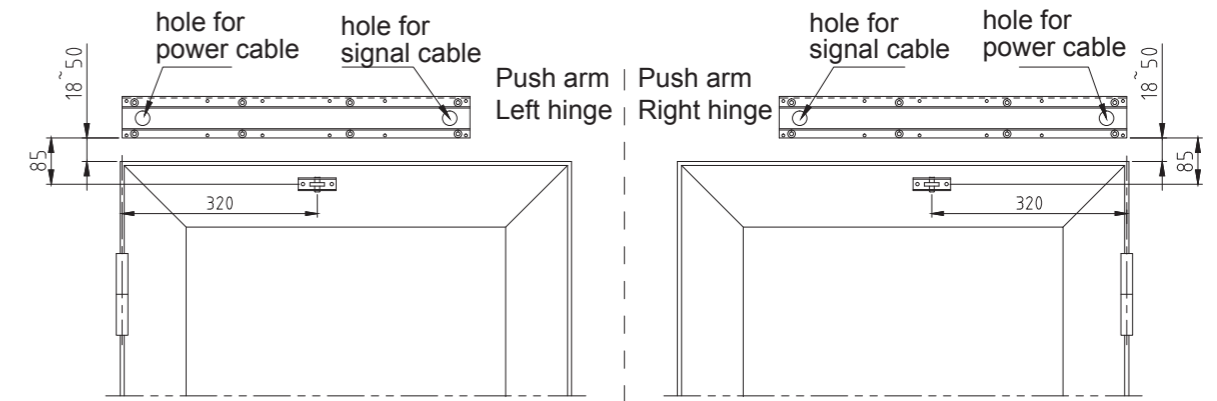

#### 2. Drive device

Hang the drive device onto the base plate and tighten with 8pcs bolts M6x12.

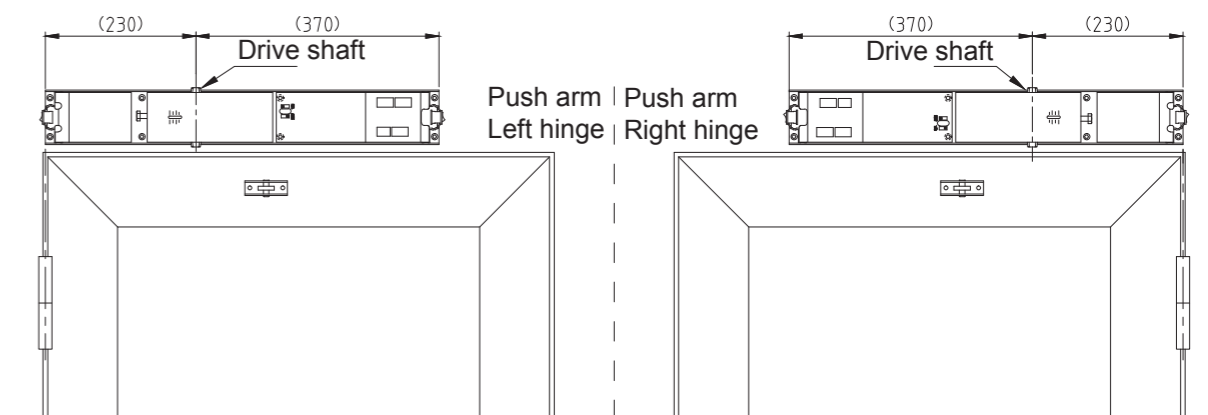
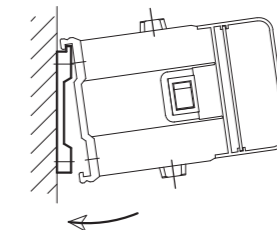

### 3. Install push arm

Take the Right hinge assembly as an example, according to the diagram, assemble the spline housing, the push arm and the drive shaft together (the end face needs to be completely fitted), check whether the push arm is within the range of 0~25, if not, rotate the spline housing 90° with respect to the drive shaft and test again until it meets the requirements.

Fasten the M8 screws and tight torque is 15 N.m.

Install the linked arm and adjust the length of it so that it is perpendicular to the door body at the door closed position.

The position of the stopper is adjusted according to the full opening angle of the door. The full opening Angle should be less than 100°, otherwise the spring in the drive device may not be able to drive the door leaf back to close.

It can be tested by pushing the door to the max. angle in the state of power failure, try to let it go, and the door leaf should be able to close slowly by itself (if the door is rapidly closing without resistance, indicating that the setting of pull/push arm shift switch S1 is wrong, see P5 "setting of installation mode").

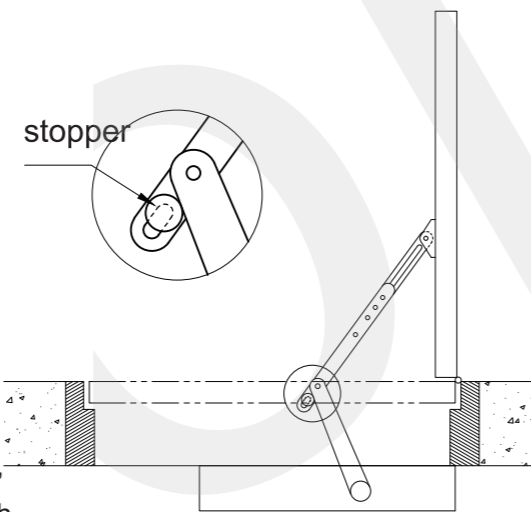
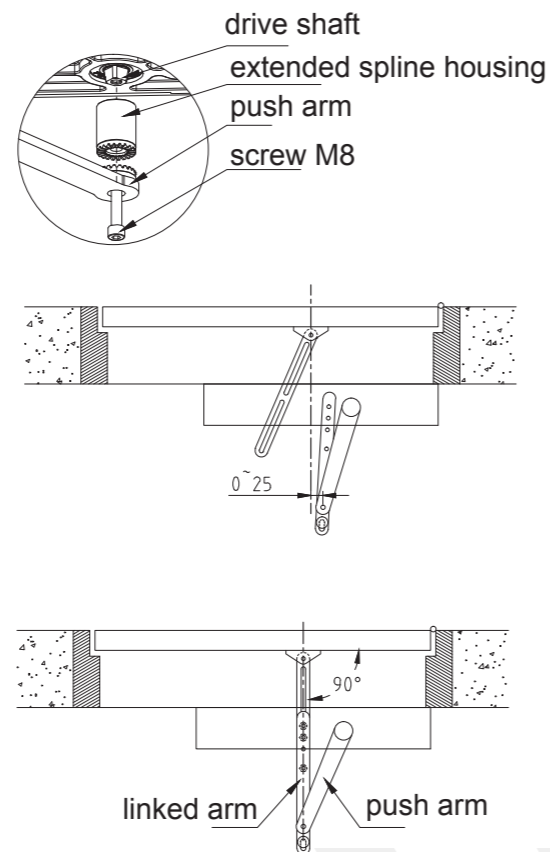

### 4. Adjust the spring force

The preloading force of the spring in the drive device is set to the minimum value by our factory. In the actual installation, the spring force can be increased according to the door weight and resistance, so that the spring can close the door smoothly; But the force should not be too big because if power failed, the door should be open by hand easily.

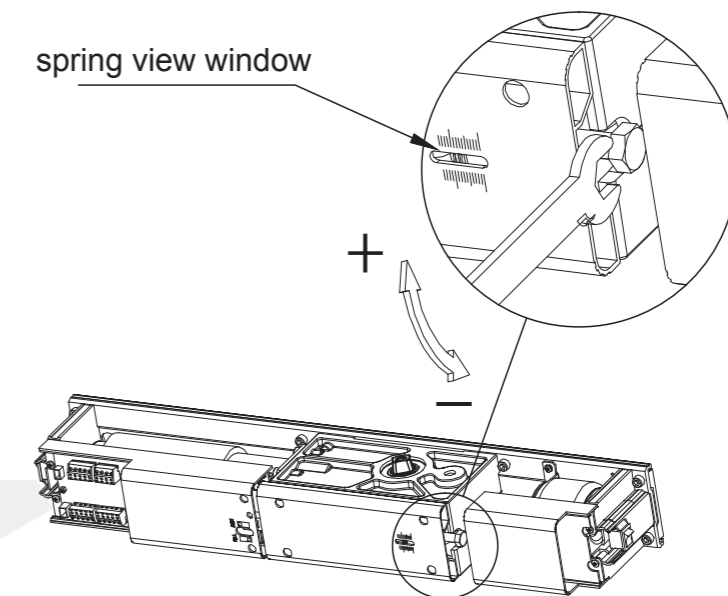

### 5. Cable connection

The power cable and signal cable are connected to their respective terminals go through the position shown in the figure. Please refer to P16 "Electronic connection" for the wiring of signal cables.

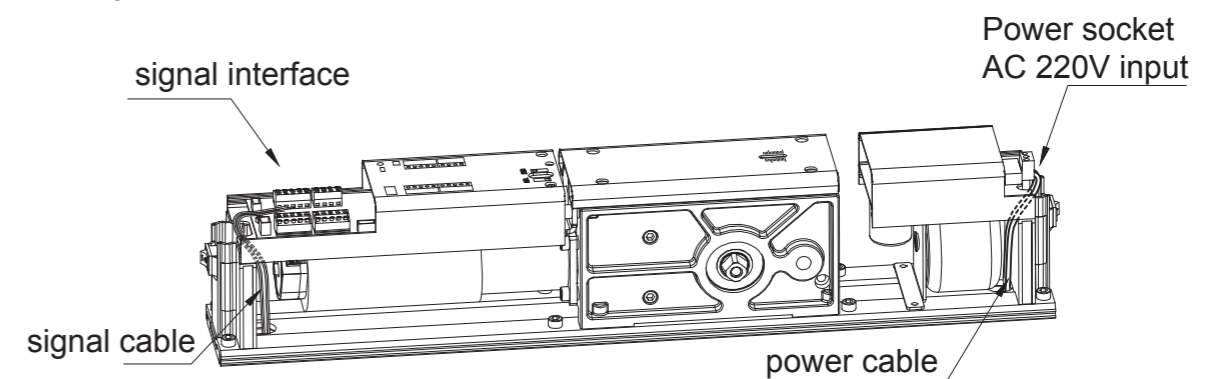

## 6. Cover and end caps

After all debugging, put on the cover and end caps.

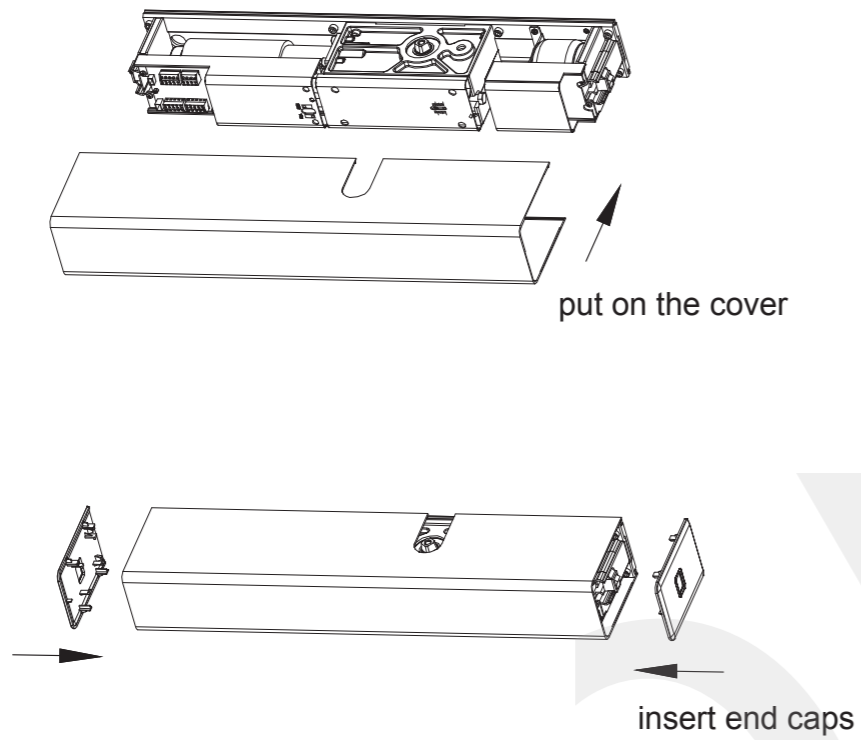

# Chapter 5 Debugging

## 1. Parameter setting

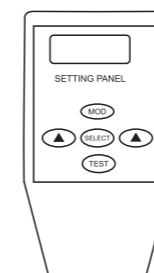
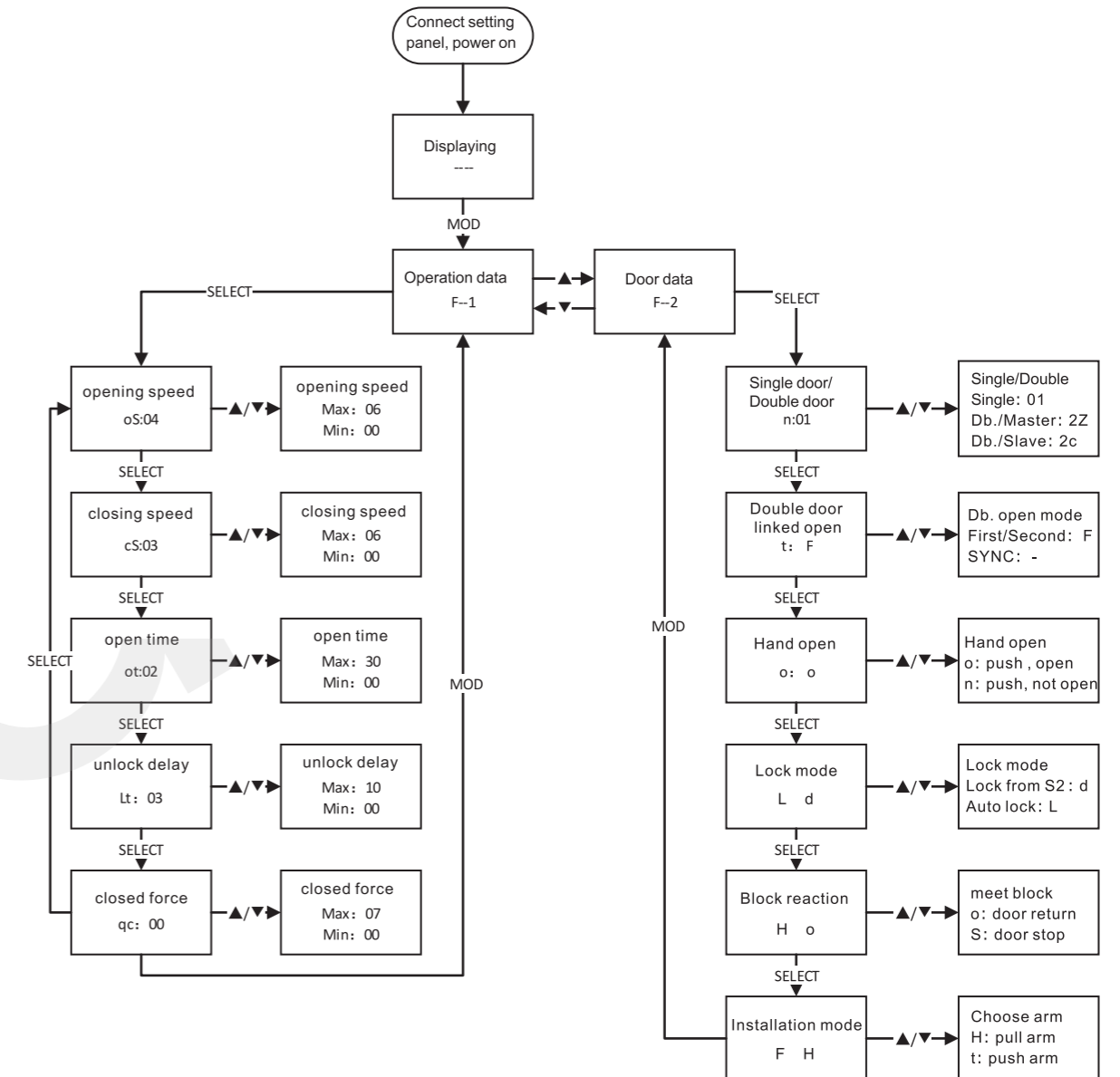

MOD: Press MOD enter into menu

▲/▼: increase / decrease

SELECT: confirm

TEST: After debugging, test before confirm



## 2. Initialization Setting

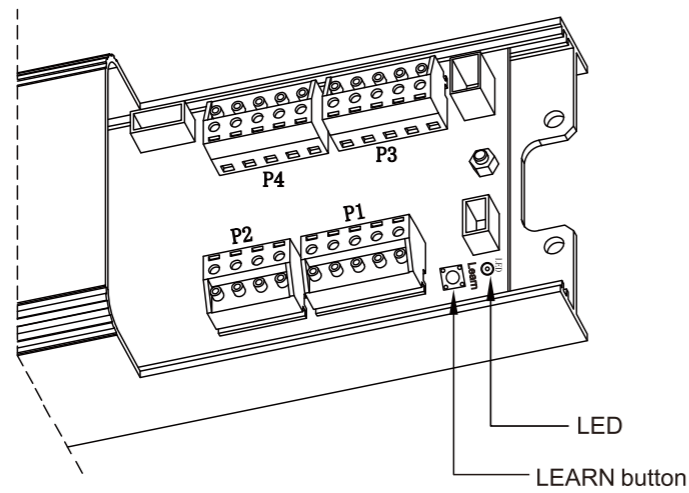

Mechanical installation finished,  
fully close the door by hand

connect setting panel  
power on, set data

press LEARN  
button until door  
start to open,

during door opening,  
the LED is twinkling,

door open normally

change installation  
mode: pull /push

full open

door close  
automatically

during door closing,  
the LED is lighting,

full closed

first start is done

## 3. State setting

Choose door state from function switch S2:

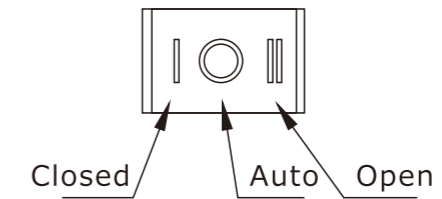

Hold-closed: sensor signal is shielded, electric lock automatically lock,  
but access control signal is effective .

Hold-open: the automatic door keep fully open.

Automatic: all signal inputs are valid.

#### 4. Electronic connection

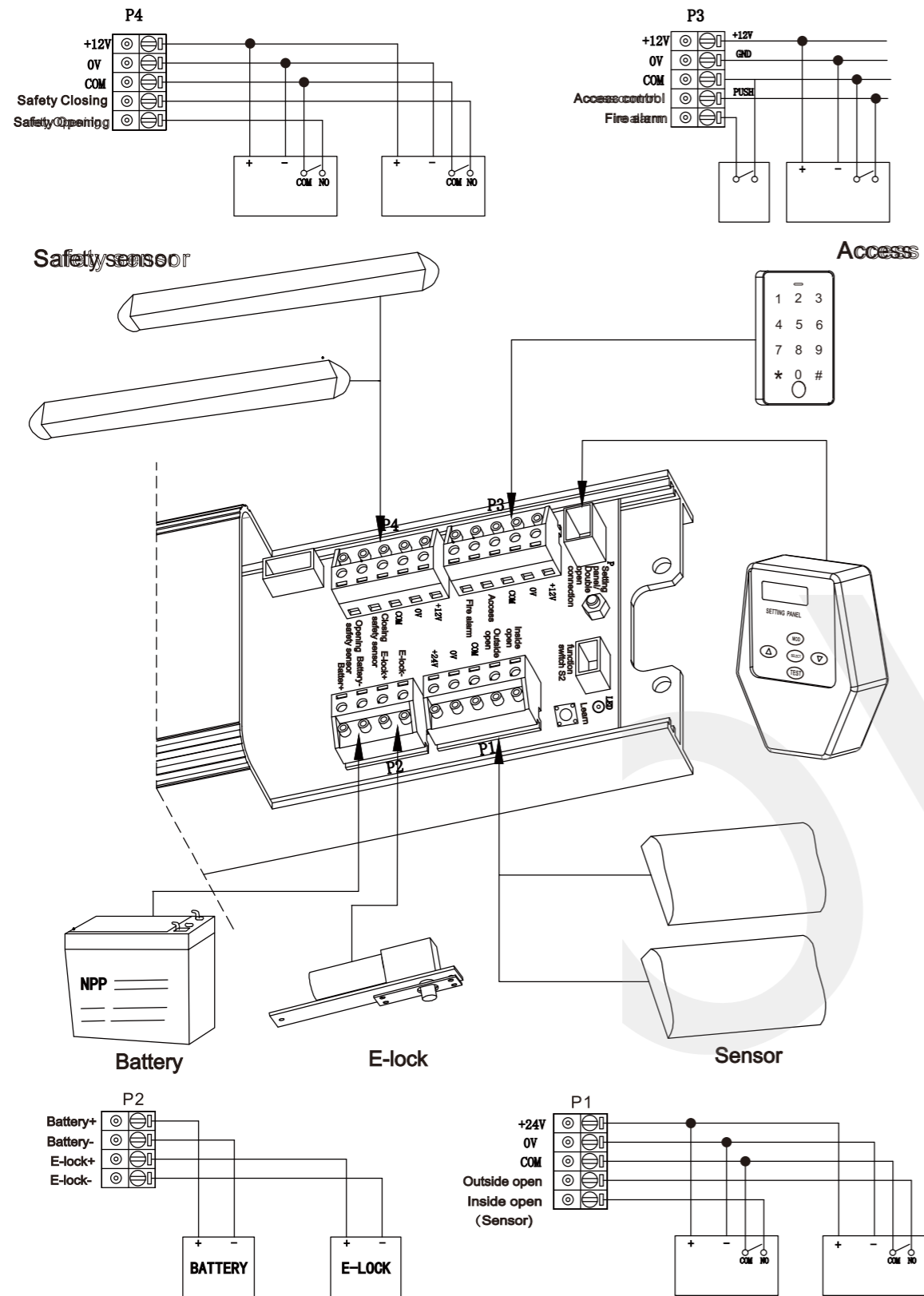

#### 5. Double open connection (option)

