

# LIGHTHOUSE LED FIRE BOWL - USA EDITION

Copper/ Corten Steel / Stainless Steel / Powder Coated



## SPECIFICATION

| MATCH LIT       | 12V                 | A   | B  | C   | D   | E   | BTU    |
|-----------------|---------------------|-----|----|-----|-----|-----|--------|
| OPT-LHFOUSAPC24 | OPT-LHFOUSAPC24E12V | 18" | 8" | 24" | 12" | 12" | 45,000 |
| OPT-LHFOUSAPC30 | OPT-LHFOUSAPC30E12V | 24" | 8" | 30" | 12" | 15" | 45,000 |
| OPT-LHFOUSAPC36 | OPT-LHFOUSAPC36E12V | 30" | 8" | 36" | 12" | 18" | 45,000 |

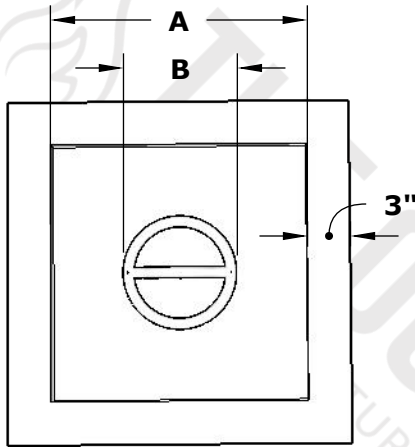

TOP VIEW

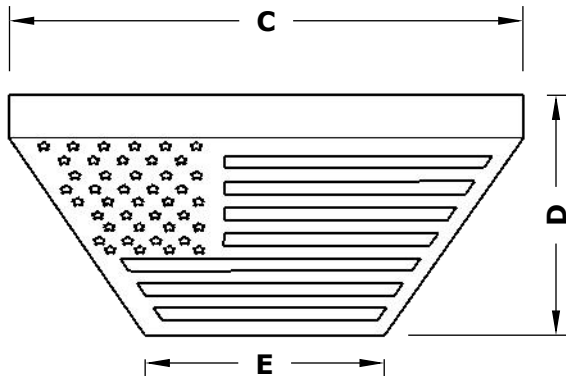

FRONT SIDE VIEW

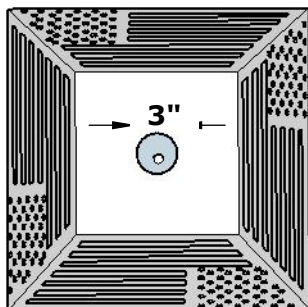

BOTTOM SIDE VIEW

### Gas Requirements

**Gas Type:** Natural Gas or Propane  
**Gas Inlet:** 1/2" NPT Female  
**Total BTU:** 65K - 125K

\*All Match Lit Units up to 65K BTU are LC Certified  
 \*\*All Electronic Units are CSA Certified



### What's Included?

#### Match Lit Unit:

- Fire Pan, Burner, Gas Orifice, Gas Hose, Key Valve with Key

#### Low Voltage Unit:

- Fire Pan, Burner, Gas Orifice, Gas Hose, Key Valve with Key, Low Voltage Electronic Valve, Pilot Ignitor

#### Plug & Play Unit:

- Fire Pan, Burner, Gas Orifice, Gas Hose, Key Valve with Key, Plug & Play Electronic Valve, Pilot Ignitor

#### 110V ELECTRONIC IGNITION

ANSI Z21.97-(2017) / CSA 2.41-(2017)

Standard 2" Depth on all pans

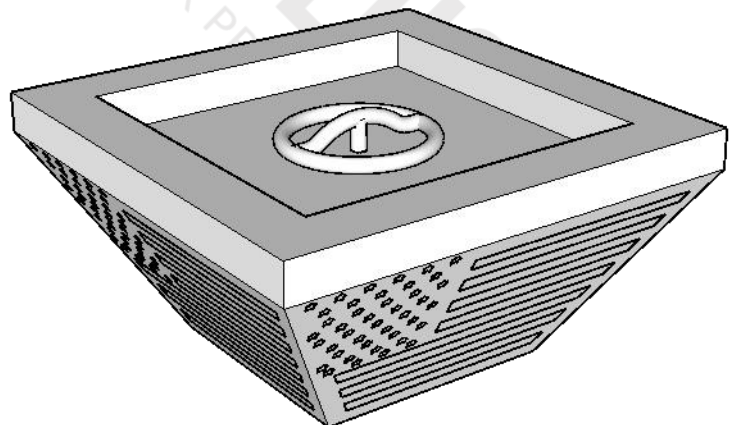

ISOMETRIC VIEW

|              |                |
|--------------|----------------|
| Drawn By     | Mia L.         |
| Date Created | August 7, 2023 |

**Proprietary & Confidential:** The information contained in this drawing is the sole property of **The Outdoor Plus**. Any reproduction or as a whole without written permission of **The Outdoor Plus** is prohibited.