

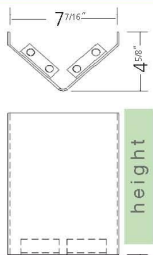

INSTALLATION INSTRUCTIONS:

L-Shaped - Floor Mounted Stainless Steel Corner Guards

	style description	height (inches)	weight (pounds)	part #
L-shaped	 <p>L-shaped profile with KWIK bolt to floor, ideally used for corners</p>	12	9	SSCP-12
		18	14	SSCP-18
		24	17	SSCP-24
		30	23	SSCP-30
		42	35	SSCP-42
		48	38	SSCP-48
		60	50	SSCP-60



Fast, Simple Installation: Captive KWIK bolt instructions – 4 bolts provided.

Tools: Drill, Drill bit and Mallet

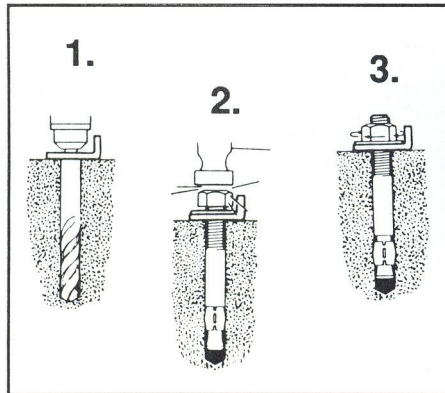

STEP 1:

Drill four 1/2" diameter x 2 5/8 deep holes, using corner guards as a template.

STEP 2:

Put nut and washer on bolt, then tap bolt into hole.

STEP 3:

Turn bolt with ratchet until tight.



- **Rounded Corners and Edges**
- **Withstands an impact of 4000 lbs**
- **10 Gauge Stainless Steel**
- **Inside Flange (no exposed hardware)**

Specifications: Constructed from 10 gauge heavy duty stainless steel. Corners are rounded and deburred of sharp edges. Surface has a smooth horizontal brush finish. Formed with a 90° and two 45° bends. Welded inside anchors (excluding SSCP-30, which as a formed base). Four 3 1/2" long x 3/8" diameter captive bolts are provided: pull out capacity, 590lbs. per fastener; shear capacity 1,280lbs. per fastener.



Maintenance: Optional deflector plate prevents build up in back. Inside Flange design provides for easy cleaning in front.