

DS18[®]

PRO

OWNER'S MANUAL

PRO-W10.4SNEO
10" NEODYMIUM
WOOFER LOUDSPEAKER
WATER RESISTANT CONE



PERFECT FOR
MOTORCYCLES

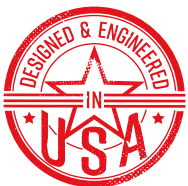

PRO-W10.4SNEO

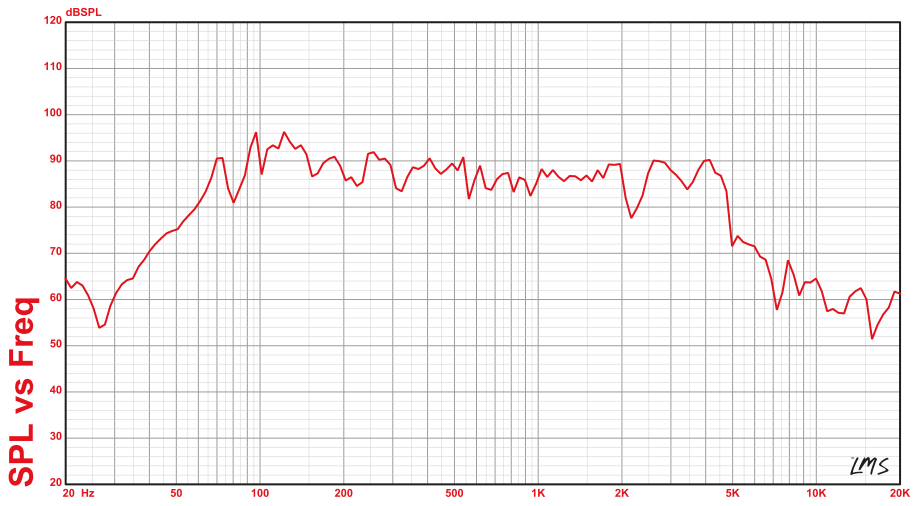
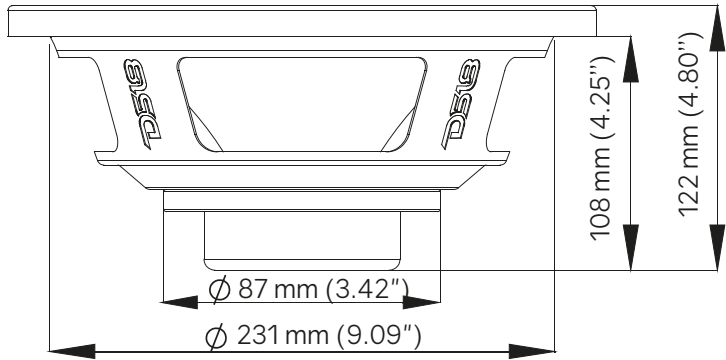
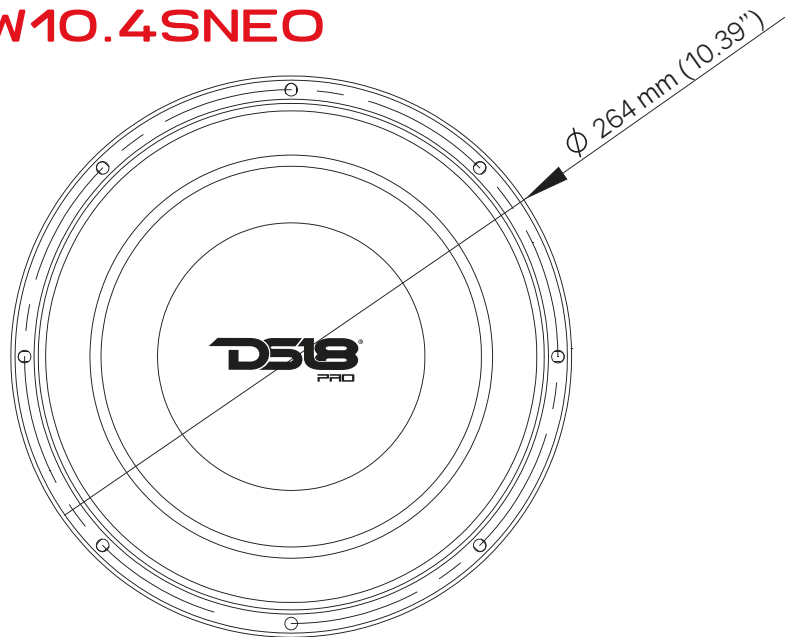

LMS



Specifications:

Nominal Diameter	10" (254mm)
Nominal Impedance	4 ohms svc
Maximum Power Handling	800 watts
RMS Power Handling	400 watts
Sensitivity (1w/1m)	91 db
Frequency Response	40Hz-5KHz
Recommended Lo Pass Crossover	180hz

Motor:

Voice Coil Diameter	2.5" (65.5mm)
Voice Coil Former Material	TiI
Winding Material	SV
Cone Material	Water resistant paper
Dust Cap Material	Water resistant paper
Surround Material	Rubber
Basket Material	Steel
Magnet Material	Neodymium
Magnet Weight	8.8 oz
Displacement Volume	1.79L

Thiele & Small Parameters:

Equivalent Volume.....	Vas	23.431 LTR
Excursion (one way).....	Xmax	12.2 mm
Free Air Resonance.....	Fs	41.5 Hz
Mechanical Factor.....	Qms	5.171
Electrical Factor	Qes	0.5
Total Factor.....	Qts	0.38
Moving Mass.....	Mms	91.85g
Compliance.....	Cms	0.16mm/N
BI Factor.....	BI	12.95
Voice Coil Inductance.....	Le	0.4578mH
Diaphragm Area.....	Sd	0.035299sq/M
Dc Resistnace.....	Re	3.2 ohms
Efficiency Bandwith Product.....	EBP	83

Measurements:

Overall Diameter	264 mm (10.39")
Overall Depth	122 mm (4.80")
Front Mount Baffle Cutout	231 mm (9.09")
Mounting Depth	108 mm (4.25")
Motor Diameter	87 mm (3.42")

PRO-W10.4SNEC

INS-7.01M-CM



FOR MORE INFORMATION
PLEASE VISIT
DS18.COM

WE LIKE IT LOUD



DS18[®]