



DS18[®]

PRO

OWNER'S MANUAL PRO-GM8.4B

8" MIDRANGE LOUDSPEAKER
WITH BULLET - 4 ohm

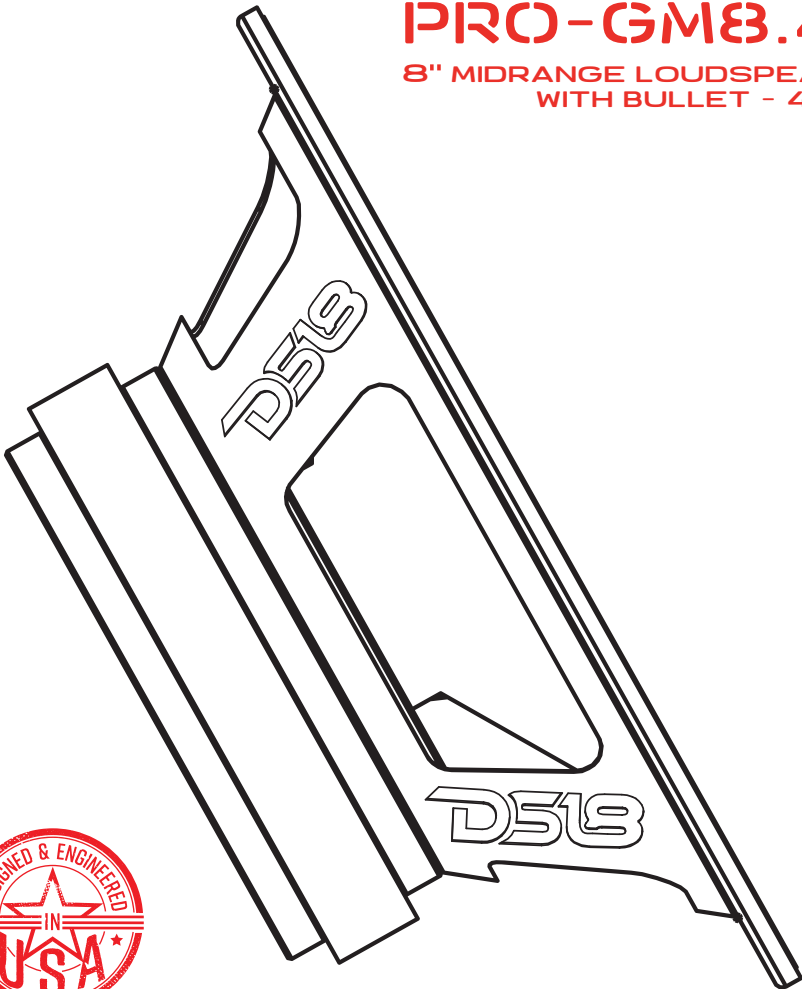

PRO-GM8.4B

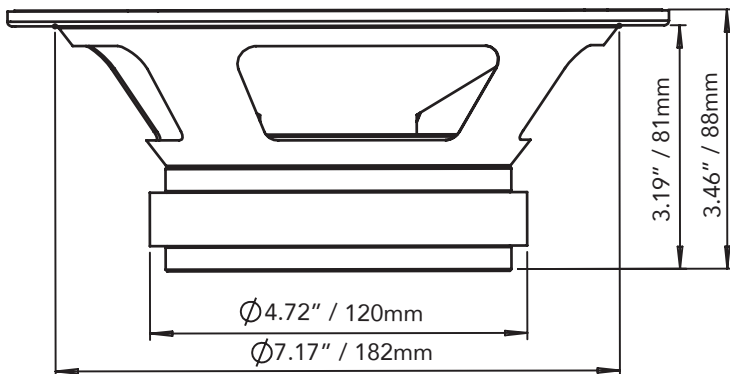
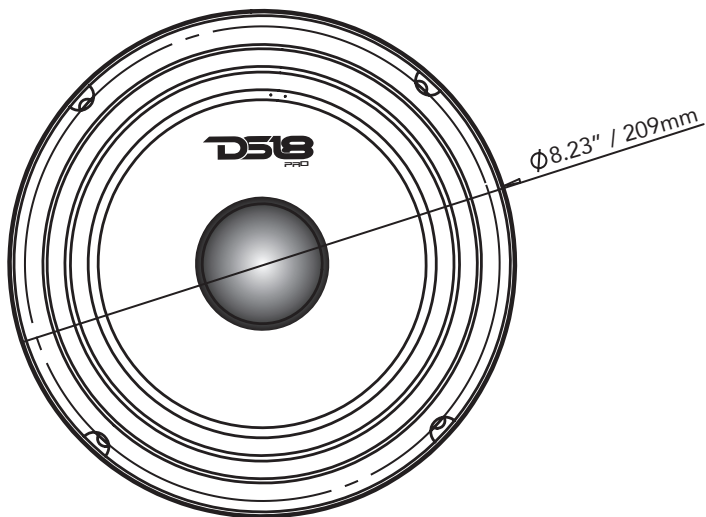

SPL vs. FREQ

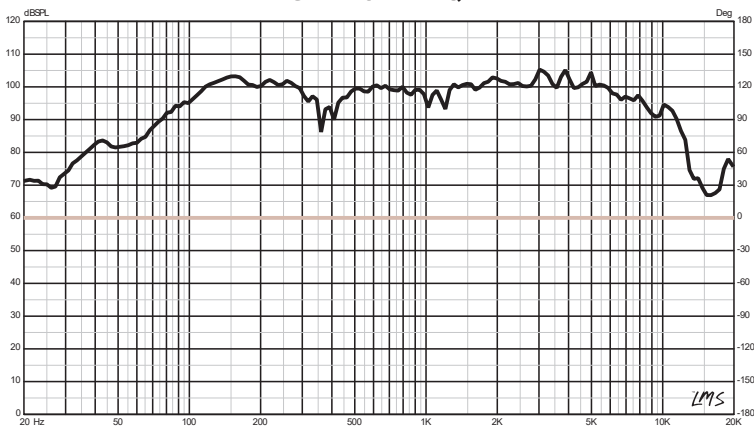



Specifications:

Nominal Diameter	8"
Nominal Impedance	4 OHM
RMS Power Handling.....	190W
Maximum Power Handling	580W
Sensitivity (1w/1m)	96dB
Frequency Response	90Hz-10KHz
Recommended Hi Pass Crossover.....	120Hz

Midrange:

Voice Coil Diameter.....	1.5"
Voice Coil Former Material	Kapton
Winding Material	KCCAW
Cone Material.....	Paper
Dust Cap Material.....	Paper
Bullet Material.....	Aluminum
Surround Material.....	Cloth
Basket Material.....	Steel
Magnet Material.....	Ferrite
Magnet Weight.....	30 oz

PRO - GMB. 413

Thiele & Small Parameters:

Vas.....	17.832L	
Equivalent Volume	Fs..... 110 Hz	
Free Air Resonance	Qms	7.857
Mechanical Factor	Qes.....	0.726
Electrical Factor	Qts.....	0.665
Total Factor	Re.....	3.2 ohm
CD Resistance		

Measurements:

Overall Diameter.....	8.23"/209mm
Overall Depth.....	3.39"/86mm
Front Mount Baffle Cutout.....	7.17"/182mm
Mouting Depth.....	3.11"/79mm
Motor Diameter.....	4.72"/120mm



FOR MORE INFORMATION
PLEASE VISIT
DS18.COM

WE LIKE IT LOUD

The DS18 logo, featuring a stylized red "D" followed by "S18" in a bold, blocky font. A registered trademark symbol (®) is located at the top right of the "8".

DS18[®]