

DS18

GEN X

GEN-X3700.4 OWNER'S MANUAL



WE LIKE IT LOUD

INSTRUCTIONS FOR FUNCTIONS AND CONTROLS

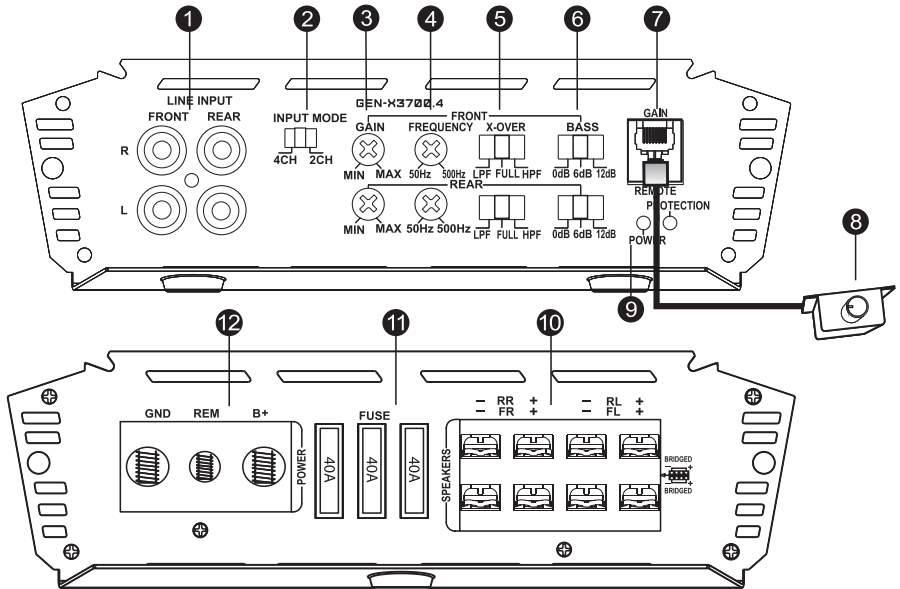

- 1 **LINE INPUT** - Left and right channels inputs of the amplifier system. Preamp outputs of a source (head unit, CD player, DAT, etc.) or of an external electronic crossover must be connected to them.
- 2 **INPUT MODE** - The switch select between 2 channels audio signal input and 4 channels audio signal input come from RCA terminal. When the switch is "4CH" position, please keep the RCA terminal have 4 channels audio signal input. When the switch is "2CH" position, the RCA terminal only needs 2 channels audio signal input and the unit may obtain 4 channels audio signal output, the 2 channels input signal may select between FRIFL and RR/RL.
- 3 **GAIN** - Knob for volume adjustment.
- 4 **HPF / LPF** - High pass frequency adjusting knob and Low pass frequency adjusting knob, the frequency ranges from 50Hz to 500Hz.
- 5 **X-OVER** - Optional switches for high pass filter (HPF) / full pass filter (FULL) / low pass filter (LPF).
- 6 **BASS BOOST**-Optional switches for 0dB / +6dB / +12dB.
- 7 **REMOTE CONTROLLER OUTLET** - To be connected with the remote controller, which help to boost the gain. Please turn the knob of volume to be maximum before using the remote.
- 8 **REMOTE CONTROLLER** - Volume level knob, the Gain ranges from 0.2V to +6V
- 9 **INDICATOR LIGHT** - When pow LED sends out green light, it means that this amplifier have being working now. When protection LED send out red light, it means that the self-protection of the amplifier.
- 10 **SPEAKER** - Speaker connecting terminal.

ELECTRICAL CONNECTION

- 11 **FUSE** - Standard automatic fuse, you must use the same power fuse if you need to change it.
- 12 **B+** - Anode of power connection terminals. Connect to the anode of car battery.
REM - Terminal to be connected with Remote cable, which comes from the source and which controls the amplifier switching on. Applied voltage must be between 10 and 15VDC.
GND - Ground terminal. Connect to the car chassis. Keep the length of the ground cable to a minimum.

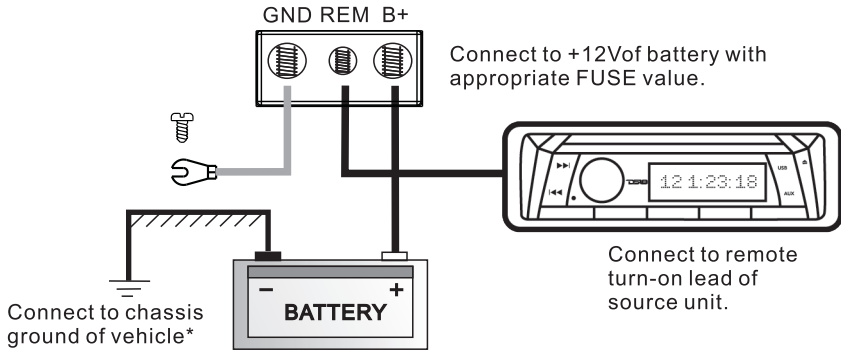

SPECIFICATIONS

MODEL	GEN-X3700.4
RMS Power @ 14.4V DC	
Power @ 4 Ohms	150W x 4
Power @ 2 Ohms	225W x 4
Bridge Power @ 4 Ohms	375W x 2
Minimum Speaker Impedance	2 Ohm
THD Distortion	0.08%
Frequency Response	20Hz~20KHz
Input Sensitivity	0.2V~+6V
Input Impedance	10K
Signal - To - Noise Ratio	98dB
Channel Separation	50dB
Remote Gain Control	0.2V~+6V
Crossover Network	
Low Pass Filter	50Hz~500Hz
Bass Boost	0dB / +6dB / +12dB
High Pass Filter	50Hz~500Hz
Fuse Rating	40A x 3
Size L x W x H	540 x 190 x 60 mm

SYSTEM WIRING - 4 CHANNEL STEREO CONFIGURATION

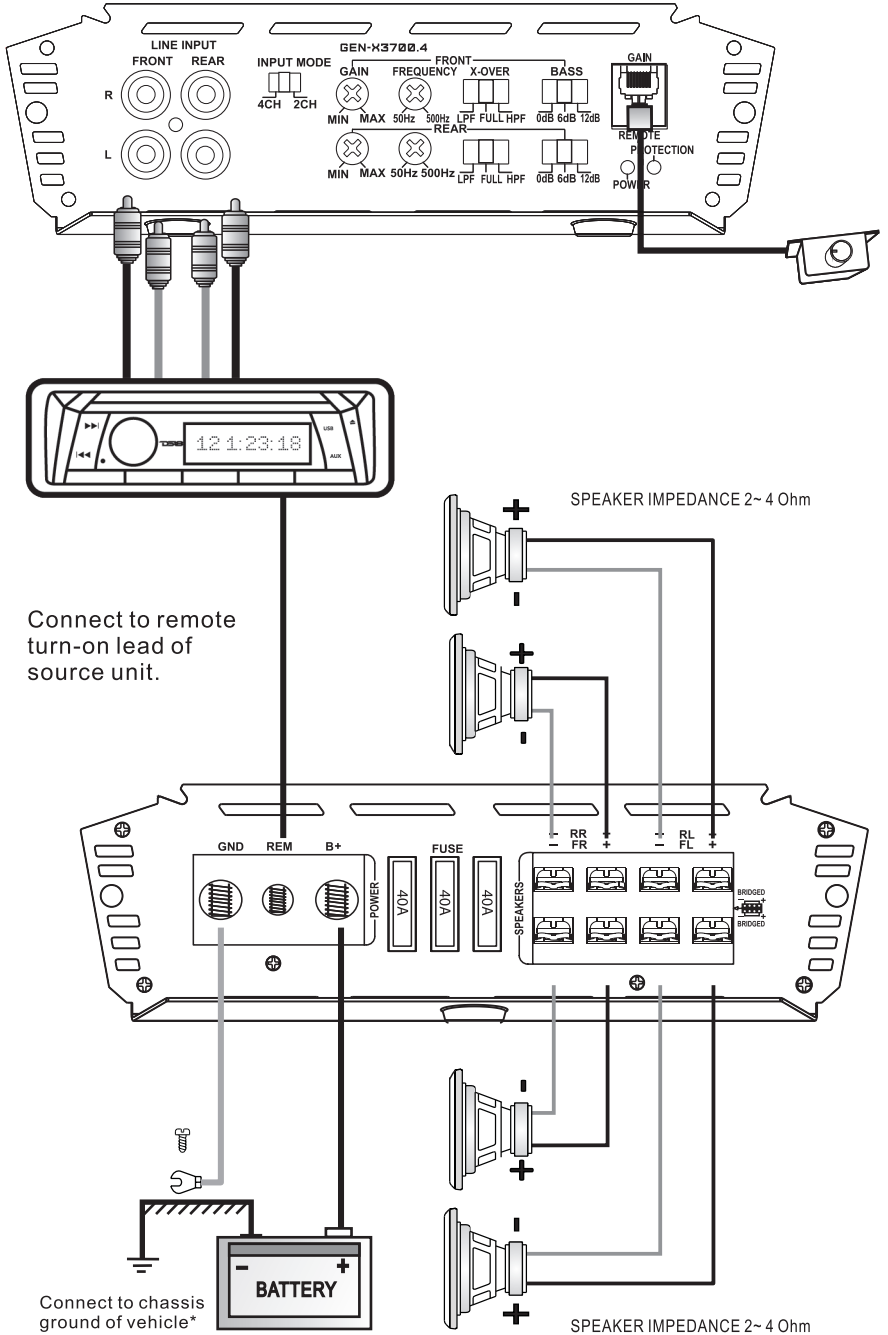

SYSTEM WIRING - 3 CHANNEL BRIDGED MODE CONFIGURATION

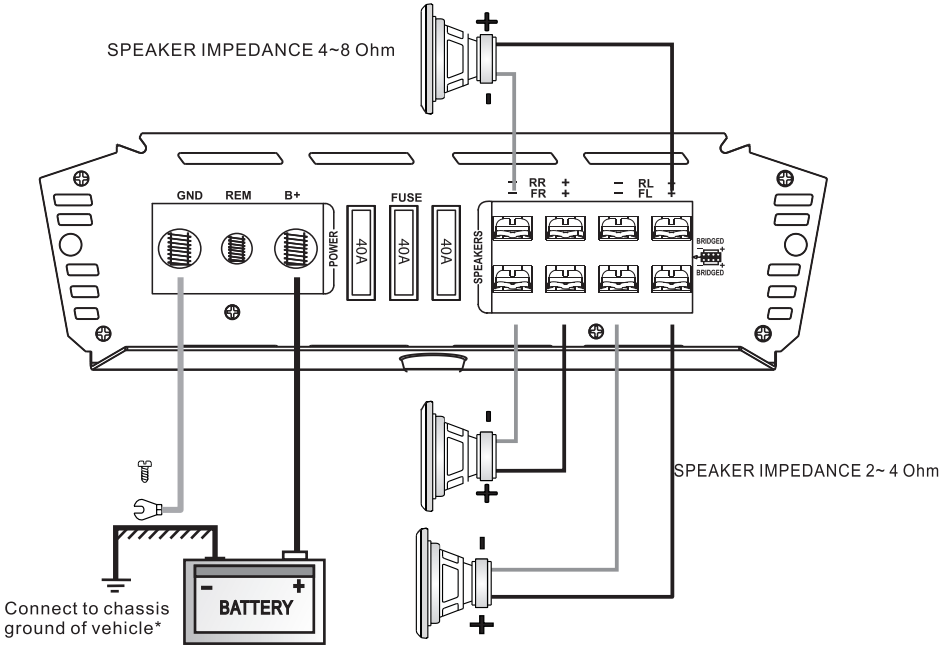

SYSTEM WIRING - 2 CHANNEL BRIDGED MODE CONFIGURATION

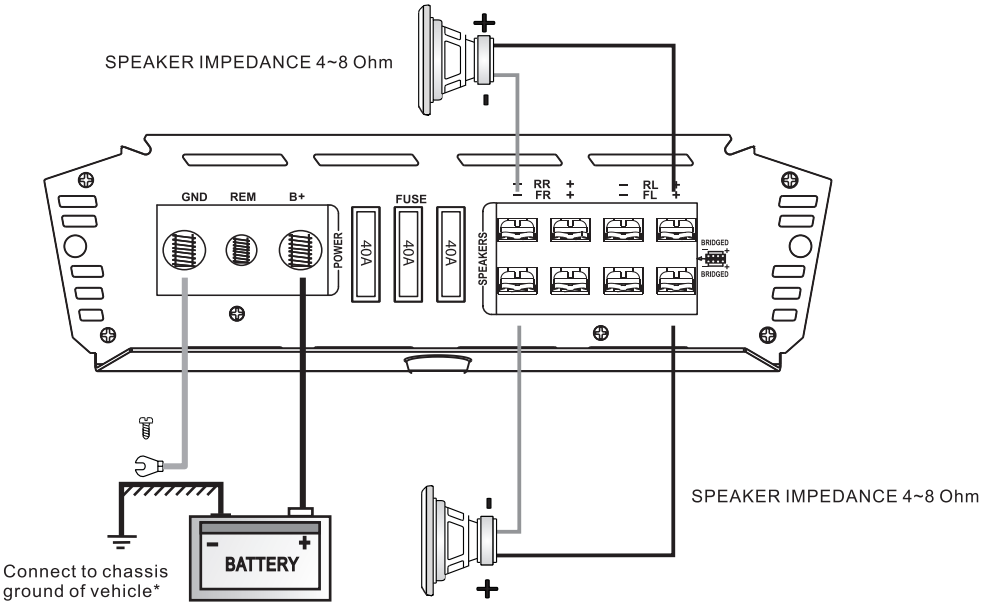

TROUBLESHOOTING

Before removing your amplifier, refer to the list below and follow the suggested procedures. Always test the speakers and their wires first.

AMPLIFIER WILL NOT POWER UP.

Check for good ground connection.

Check that remote DC terminal has at least 10V DC.

Check that there is battery power on the + terminal.

Check all FUSES.

Check that Protection LED is not lit. If it is lit, shut off amplifier briefly and then re power it.

HIGH HISS OR ENGINE NOISE (ALTERNATOR WHINE) IN SPEAKERS.

Disconnect all RCA inputs to the amplifier, if hiss / noise disappears, then plug in the component driving the amplifier and unplug its inputs.

If hiss / noise disappears, go on until the faulty / noisy component is found. It is best to set the amplifier input level as insensitive as possible. The best subjective S/N ratio is obtainable this way. Try to drive as high a signal level from the head unit as possible.

PROTECTION LED COMES ON WHEN THE AMPLIFIER IS POWERED UP.

Check for shorts on speaker leads.

Check that volume control on the head unit is turned down low.

Remove speaker leads, and reset the amplifier. If the Protection LED still comes on, then the amplifier is faulty.

The amplifier will shut down automatically when the units' temperature goes up to 85°C This will protect the units from damage.

AMPLIFIER'S GETS VERY HOT.

Check that the minimum speaker impedance for that model is correct. Check for speaker shorts.

Check that there is good airflow around the amplifier. In some applications, an external cooling fan may be required.

DISTORTED SOUND.

Check that the Level control's is set to match the signal level of the head unit.

Check that all crossover frequencies have been properly set.

Check for shorts on the speaker leads.

HIGH SQUEAL NOISE FROM SPEAKERS.

This is always caused by a poorly grounded RCA patch cord.

WARNING

1. Over high volume will damage your speakers.
2. Be cautious when you use the amplifier near gasoline tank and electric wires.
3. Protect the connecting wires and parts to avoid any damage or short circuit.
4. The power must be lee from the anode of the battery via FUSE.
5. The sound system must be in turning-off situation when you check the amplifier.
6. Be sure that you use the same type of FUSE when you need to replace it .

* We reserve the right to make needed change or improvement to the product, without informing customer about this in advance.