



K A C O 
new energy.

**Powador-
protect**

Operating Instructions

■ English translation of German original

These instructions form part of the product and must be observed. They must also be stored in a place which is freely accessible at all times.

The copyright for these operating instructions is held solely by KACO new energy GmbH.

Operating Instructions

Contents

1	General information	4
2	Safety	6
3	Technical Data	8
4	Transportation and Delivery	13
5	Mounting	15
6	Device overview	18
7	Electrical connection	20
8	Connecting the interfaces	24
9	Starting up the Powador-protect	33
10	Configuration and Operation.....	34
11	Maintenance/Troubleshooting	45
12	Warranty and Service.....	48
13	Disposal	50
14	EU Declaration of Conformity	51

1 General information

1.1 About this document



WARNING

Improper handling of the device can be hazardous



You must read and understand the operating instructions in order to install and use the device safely!

Other applicable documents

During installation, observe all assembly and installation instructions for components and other parts of the system. These instructions also apply to the equipment, related components and other parts of the system.

Storing the documents

These instructions and other documents must be stored near the system and be available at all times. The content of these instructions is revised on a regular basis and updated if necessary. You can download the current version of the operating instructions at www.kaco-newenergy.com.

1.2 Layout of Instructions

Symbols used



General hazard



Risk of fire or explosion



Electrical voltage



Risk of burns

Safety warnings symbols guide



DANGER



High risk

Failure to observe this warning will lead directly to serious bodily injury or death.



WARNING



Potential risk

Failure to observe this warning may lead to serious bodily injury or death.



CAUTION



Low-risk hazard

Failure to observe this warning will lead to minor or moderate bodily injury.

CAUTION

Risk of damage to property

Failure to observe this warning will lead to property damage.

Additional information symbols



NOTE

Useful information and notes

2 Safety

2.1 Proper use

Correct use of the Powador-protect entails

- Monitoring the voltage 3*Ph-N
- Monitoring the voltage 3*Ph-Ph
- Monitoring the (three-phase) frequency
- Reading digital signals for remote-controlled power reduction of PV systems
- Controlling interface switches
- Controlling the output relays separately as a backup protection concept for controlling internal interface switches on compatible KACO inverters.

Any other or additional use of the device shall be regarded as improper.

This includes:

- Mobile use,
- Use in rooms where there is a risk of explosion,
- Operation outside of the specifications intended by the manufacturer



DANGER

Danger to life from electric shock!



- › Observe all safety regulations and the current technical connection specifications from the relevant power supply company.
- › Only appropriately qualified electricians authorised by the mains supply network operator are permitted to install and maintain the device.
- › Do not touch the exposed ends of the cables.
- › Avoid short circuits.

2.2 Other functions

When using suitable KACO inverters, the shutdown can be carried out via the grid separation relay integrated into the inverters and the "Inverter OFF" digital output instead of via interface switch.

If a Powador-protect is used for fast shutdown, it must be used as grid protection.

3 Technical Data

3.1 Electrical data

Supply	
Voltage supply [V_{AC}]	100 ... 264
Nominal voltage U_{nom} [V_{AC}]	230
Max. power consumption [W]	2.5
Measurement	
Measurement voltage: Range/nom [V_{AC}]	0 ... 290 / 230
Voltage measurement tolerance	< 1 % U_{nom} (@ $U_{nom} = 230 V$)
Frequency: Range/nom [Hz]	40 ... 70 / 50
Frequency measurement tolerance [Hz]	< 0.1
Rated frequency [Hz]	50
Drop-off ratio for overvoltage/frequency [Hz]	< 1.01
Drop-off ratio for undervoltage/frequency [Hz]	> 0.99
Overvoltage category	III
Electrical protection class	II
Actuation of external interface switches	
Max. AC current (inductive) [A]	2.0
Max. AC voltage [V_{AC}]	250
Max. DC current [A]	8.0
Max. DC voltage [V_{DC}]	30
"Inverter off" shutdown signal	
Output voltage clocked [V_{DC}]	12

3.2 Mechanical data

Interfaces	
Measurement	Screw terminals 4-pin (L1/L2/L3/N)
Switch contacts	2 changeover contacts for connecting external interface switches
Ripple control receiver	Screw terminals, 5-pin
to the inverter	Screw terminals for digital output, RS485-Bus. RJ45 socket for RS485
Terminals	
Length of insulation to be stripped off	8 mm
Tightening torque	0.5 ... 0.6 Nm
Conductor cross-section	
1 conductor, rigid, no wire sleeves	0.2 ... 4.0 mm ²
1 conductor, flexible, no wire sleeves	0.25 ... 2.5 mm ²
2 conductors, rigid/flexible, no wire sleeves	0.2 ... 1.5 mm ²
2 conductors, flexible, with wire sleeves	0.25 ... 0.75 mm ²
General mechanical data	
Display	LCD (2 x 16 characters), 3 LEDs
Controls	2 control buttons, 1 release test
Mounting	Top-hat rail or wall mount

Ambient temperature range [°C]	-20 ... +70
Maximum installation elevation (m above mean sea level)	2000
Protection rating according to EN 60529	IP20
Housing	Polycarbonate
H x W x D [mm]	89.5 x 107 x 63
Weight [g]	310

3.3 Setting values

Icon	Meaning
U	Voltage in V
U10M	Voltage in V as 10-minute mean value
f	Frequency in Hz
>/>>	Voltage increase protector level 1/level 2
</<<	Frequency drop protector level 1/level 2
R	Reconnection threshold in s
x	Phase (possible values: 1, 2, 3)

Country setting "Germany"	Setting values	Response times
U>	1.15 U _{nom}	100 ms
U10M>	1.1 U _{nom}	100 ms
U<	0.80 U _{nom}	100 ms
f>	51.5 Hz	100 ms
f<	47.5 Hz	100 ms

Country setting "IT-CEI021"	Setting range		Default values	
	Value	Time	Value	Time
U>	1...1.2 U _{nom}	0.2...10 s	1.1 U _{nom}	3 s
U>>	1...1.3 U _{nom}	0.05...5 s	1.15 U _{nom}	0.2 s
U<	0.2...1 U _{nom}	0.05...5 s	0.85 U _{nom}	0.4 s
U<<	0...1 U _{nom}	0.05...5 s	0.4 U _{nom}	0.2 s
f> eng	50 to 52 Hz	0.05...5 s	50.5 Hz	0.1s
f> broad	50 to 52 Hz	0.05...5 s	51.5 Hz	0.2s
f< eng	47 to 50 Hz	0.05...5 s	49.5 Hz	0.1 s
f< broad	47 to 50 Hz	0.05...5 s	47.5 Hz	0.2 s

Free adjustment				
"User-defined"	Setting range		Default values	
	Value	Time	Value	Time
Power control	ENABLE/ DISABLE	-	ENABLE	-
Unom	220 - 240 V	-	230 V	-
Tstart	-	0 ... 1800 s	-	0 s

Free adjustment				
"User-defined"	Setting range		Default values	
	Value	Time	Value	Time
Twait	-	0 ... 1800 s	-	0 s
U10M	1 ... 1.25 U_{nom}	-	1.25 U_{nom}	-
U>>	$U>^* \dots 1.26 U_{nom}$	0 ... Toff(U>) ms	1.2 U_{nom}	100 ms
U>	1 ... $U>>^* U_{nom}$	Toff(U>>) ... 99990 ms	1.08 U_{nom}	20000 ms
UR>	0.9 ... $U>^*$	-	1.08 U_{nom}	-
U<	$U<<^* \dots 1 U_{nom}$	Toff(U<<) ... 99990 ms	0.80 U_{nom}	1000 ms
U<<	0.1 ... $U<^* U_{nom}$	0 ... Toff(U<) ms	0.45 U_{nom}	300 ms
UR<	$U<^* \dots 1.1 U_{nom}$	-	0.95 U_{nom}	-
F>>	$F>^* \dots 65 \text{ Hz}$	0 ... Toff(F>) ms	51.5 Hz	100 ms
F>	50 ... $F>>^* \text{ Hz}$	Toff(F>>) ... 99990 ms	51.5 Hz	100 ms
FR>	50 ... $F>^*$	-	50.05 Hz	-
F<	$F<<^* \dots 60 \text{ Hz}$	Toff(F<<) ... 99900 ms	47.5 Hz	100 ms
F<<	42.5 ... $F<^* \text{ Hz}$	0 ... Toff(F<) ms	47.5 Hz	100 ms
FR<	$F<^* \dots 60$	-	47.5 Hz	-

*) The value is dependent on the voltage/frequency range.

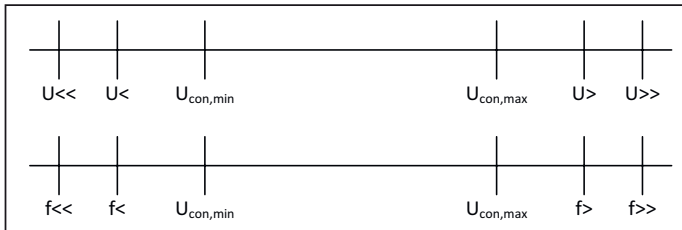

Figure 1: "User defined" settings diagram

3.4 Operating system

The devices uses the open source operating system FreeRTOS 7.00 (<http://www.freertos.org>).



4 Transportation and Delivery

Delivery

Every product leaves our factory in perfect electrical and mechanical condition. Special packaging ensures that the units are transported safely. The shipping company is responsible for any transport damage that occurs.

Scope of delivery

- 1x Powador-protect
- 4x jumpers for bus termination
- 1x cable set for AC connection
- 1x ferrite clip
- Documentation

5 Mounting



DANGER

Danger of death from high voltages

Severe injuries or death may occur if the cables and terminals in the device are touched.

The device is only permitted to be installed by an authorised electrician. The device must be mounted in a fixed position before being connected electrically.



- › Observe all safety regulations and current technical connection specifications of the responsible power supply company.
- › Make sure there is absolutely no voltage present.
- › Only then should the device be connected.



DANGER

Risk of fatal injury from fire or explosions!

Fire caused by flammable or explosive materials in the vicinity of the device can lead to serious injuries.



- › Do not mount the device in potentially explosive atmospheres or in the vicinity of highly flammable materials.

Requirements for the installation space

- Contact protection for the device and connection leads must be ensured
- Installation in the immediate vicinity of the feed-in meter
- Observe the required dimensions
- The installation space must be dry and well ventilated, and must also permit unhindered air circulation
- Ensure sufficient heat dissipation, where necessary via forced ventilation
- For simple operation, ensure that the device is installed so that the display is positioned slightly below eye level
- The installation site should be easily accessible
- Top hat rail in control cabinet or meter cabinet, optional wall mounting



NOTE

Access by maintenance personnel for service

Any additional costs arising from unfavourable structural or mounting conditions shall be billed to the customer.

5.1 Mounting the device on a top hat rail

- Mount the device in the immediate vicinity of the feed-in meter.
 1. Place the device with the upper fastening on a suitable top hat rail (I).
 2. Press the device downwards against the top hat rail (II).
 3. Lock the device into position in the top hat rail (III).

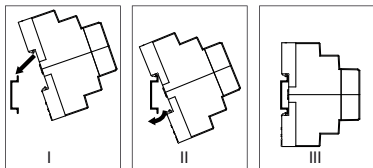

Figure 2: Top hat rail mounting

5.2 Mounting the device onto a wall

- Mount the device in the immediate vicinity of the feed-in meter.
- 1. Press out the 2 holders on the rear of the device
- 2. Screw the device onto the wall using 2 fixing screws (max. diameter 3.5 mm).

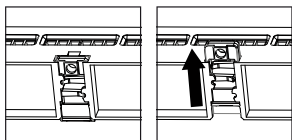

Figure 3: Wall holders on the rear of the device

6 Device overview

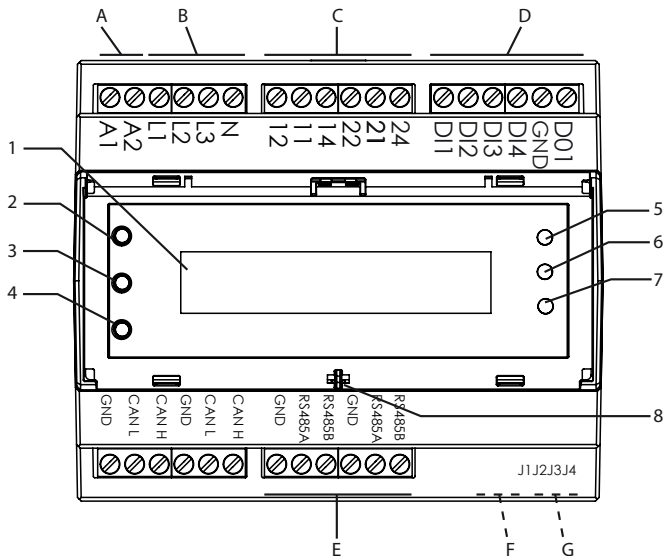

Figure 4: Device overview

Device overview

1	Display	5	Action button
2	"Operating" LED	6	Forward button
3	"Feed-in" LED	7	Test button
4	"Fault" LED	8	Feed-through for sealing wire

Connector strip on the upper side of the housing

Electrical connections	Description
A A1, A2	Connection terminals for AC power supply
B L1, L2, L3, N	Measurement inputs for three phase voltage monitoring and frequency monitoring
C 12, 11, 14 22, 21, 24	Switch contacts to actuate 2 external interface switches

Interfaces	Description
DI1, DI2, DI3, DI4	Digital inputs. Evaluation of potential-free contact
D GND	Common mass connection for digital inputs and digital output
DO1	Digital output for shutdown signal "Inverter off". 12V DC clocked.

Connector strip on the lower side of the housing

Interfaces	Description
E 2x GND, 2x RS485A, 2x RS485B	Connection terminals for RS485 bus connection
F RJ45 socket (lower side of the housing)	Optional: Bus connection via Ethernet cable
G J1, J2, J3, J4 (underside of the housing)	4 rows of pins for bus termination via jumpers

7 Electrical connection

Make the electrical connection via the screw terminals on the top of the device. Use a slot screwdriver (max. blade width: 3 mm).

You will require the following additional materials that are not included with the powador-Protect:

- Connection material, wire sleeves if necessary
- suitable fuses

The use of the digital inputs and outputs is country-specific. Note the relevant instructions.

7.1 General information

The integrated power supply is designed for a supply voltage of 100 - 264 V_{AC}.

You can use AC or DC supplied interface switches.

NOTE

Grid failure bridging time

With a supply voltage of 230 V to <50 V, the grid failure bridging time is 280 ms.

With a supply voltage drop below 100 V, the grid failure bridging time is 5 s.



An extended undervoltage operation is regarded as improper usage. An additional fuse of the voltage supply (USV) should be included in this case.

The grid failure bridging time of the interface switches should be observed. If necessary, the grid connection rule requires that the interface switch is not triggered before the set trigger delay time.

When using the internal interface switches and suitable KACO inverter, adequate grid failure bridging time must be provided at all times.

NOTE



If AC-supplied interface switches are used, the AC connection can be simplified.

- › Use the wire jumper provided to bridge inputs A1, L1, 11 and 21.

Recommended conductor cross-sections and fuse protection of NYM cables for fixed wiring according to VDE 0100 part 430:

- Conductor cross-section: 1.5 mm²
- Fuse protection: Automatic circuit breakers, 16 A for 1.5 mm² conductor cross-section

7.2 AC connection



DANGER



Danger to life from electric shock!

Severe injury or death will result if the live connections are touched.



- › Before all work, ensure that there is absolutely no voltage present.

NOTE



In the system installation, a switch or circuit breaker must be fitted as a disconnection unit. This must

- › be suitably positioned
 - › to be accessible for the user
 - › be marked as a disconnection unit for the device
-

7.2.1 AC connection with the wire jumper provided

- ⌚ Observe the input voltage
 - ⌚ Observe the cable cross-sections
 - ⌚ Use a suitable fuse
 - ⌚ The interface switches used must be AC supplied
1. Remove the cover of the pre-stripped wire end of the wire jumper
 2. Connect screw terminals L1, 11 and 21 to the 3 connections of the wire jumper fitted with wire sleeves
1. Connect neutral conductor N to screw terminal A2
 2. Connect the stripped wire end of the jumper and the AC supply line to screw terminal A1
- » Connect AC measurement lines

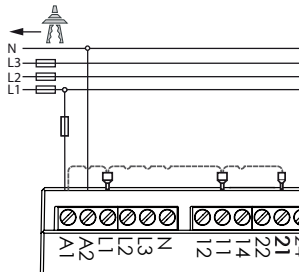

Figure 5: AC connection with wire jumper

7.2.2 AC connection without the wire jumper provided

- ⌚ Observe the input voltage
 - ⌚ Observe the cable cross-sections
 - ⌚ Use a suitable fuse
1. Connect neutral conductor N to screw terminal A2
 2. Connect AC supply line to screw terminal A1
- » Connect AC measurement lines

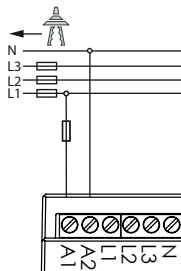

Figure 6: AC connection without wire jumper

7.2.3 Connect AC measurement lines

Required to monitor undervoltage, overvoltage, underfrequency and overfrequency

- ⌚ Make AC connection. Use suitable fuses!
- ☞ Connect AC measuring lines (L1, L2, L3) and neutral conductor N to the relevant screw terminals (L1, L2, L3, N)

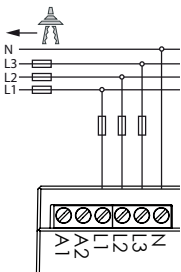

Figure 7: AC supply and AC measuring lines (with wire jumper)

8 Connecting the interfaces

Connect the interface lines via the screw terminals to the upper and lower side of the device.



DANGER



Danger to life from electric shock!

Severe injury or death will result if the live connections are touched.



- › Before all work, ensure that there is absolutely no voltage present.

8.1 Connect interface switches



NOTE

Germany,
User defined

With exclusive use of suitable KACO inverters in the generation plant being monitored, no external interface switches are required.

Supply	Contact load capacity on the Powador-protect
AC	250 V / 2 A inductive
DC	24 V/8 A

Connect AC supplied interface switch (Figure 8)

- ⌚ You have installed 2 suitable external interface switches between feed-in meter and generation plant.
1. Connect "A1" connection of interface switch 1 to terminal "14" of the Powador-protect.
 2. Connect "A2" connection of interface switch 1 to neutral conductor N of the AC voltage supply.
 3. Connect terminal "11" of the Powador-protect to a phase of the AC voltage supply.
- 👉 The connection of interface switch 2 is made on the same principle (A1 to "24", A2 to "N", L1 to "21").

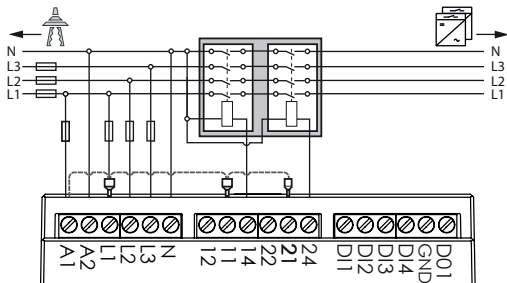

Figure 8: AC-supplied interface switch, installation with wire jumper

Connecting the DC-supplied interface switch (Figure 9)

- ⌚ You have installed 2 suitable external interface switches between feed-in meter and generation plant.
1. Connect "A1" connection of interface switch 1 to terminal 14 of the Powador-protect.

2. Connect "A2" connection of interface switch 1 to the minus pole of the DC voltage supply.
 3. Connect plus pole of the DC supply to terminal "11" of the Powador-protect.
- ☞ The connection of interface switch 2 is made according to the same principle (A1 to "24", A2 to DC-, DC+ to "21").

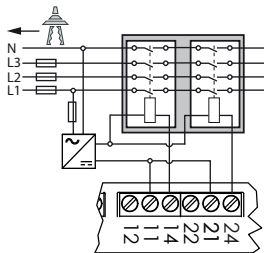

Figure 9: DC-supplied interface switch

8.2 Digital inputs

8.2.1 Connect ripple control receiver

for feed management by the power supply company.

Country settings: "Germany", "Power Control", "User Defined"

Observe the installation and operating regulations of the ripple control receiver.



NOTE

The Powador-protect has an individual GND connection. A bridging of the GND connection of the ripple control receiver can therefore be required outside the device.

Connecting the ripple control receiver to the Powador-protect

- You have correctly fitted and installed the ripple control receiver.
- Note the control stages! Terminal "1" (100% nominal power) to terminal "4" (0% nominal power)
- ☞ Attach connection leads to the corresponding connection terminals (DI1, DI2, DI3, DI4, GND).

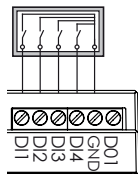

Figure 10: Ripple control receiver

Configure Powador-protect for ripple control receiver

- Observe the grid operator specifications!
 1. Open menu level 3.
 2. Change "Pwr-Ctr active" option to "Yes".
 3. Configure 4 control stages "Pwr-Ctr DI1" to "Pwr-Ctr DI4" and option "Pwr-Ctr All DI".

If no ripple control receiver is connected to the device, the option "Pwr-Ctr active" should be set to "No".

8.2.2 Connect signal sources for remote shutdown and frequency limitation

to monitor undervoltage, overvoltage, underfrequency and overfrequency.

Country setting: "IT-CEI021"

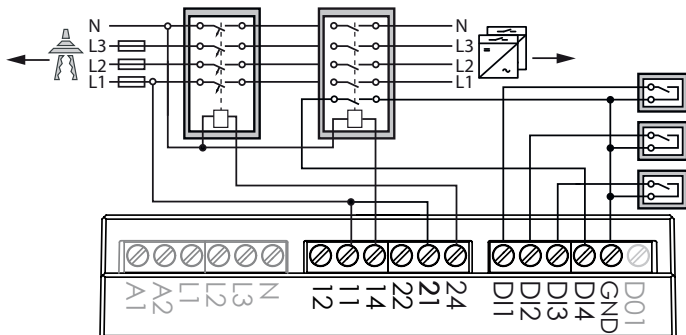

Figure 11: AC interface switch; signal sources for remote shutdown and frequency limitation

D11: Remote shutdown

1. Connect connection leads of the signal source for the remote shutdown to connection terminals D11 and GND.
2. After commissioning: Configure "Remote tripping" setting.

D12/D13: Frequency shutdown limits

- ☞ Connect connection leads of the first signal source for the frequency shutdown limits to connection terminals D12 and GND.
- ☞ Connect connection leads of the second signal source for the frequency shutdown limits to connection terminals D13 and GND.



NOTE

Whilst one of the two inputs D12 or D13 is connected to GND, the other frequency shutdown limits are active. Otherwise the tight frequency shutdown limits are active.

8.2.3 Connect feedback contact of the interface switch

to monitor the triggering of the interface switch.

Country setting: "IT-CEI021".

The triggering of the interface switch is monitored. If no opening of the interface switch is detected within 500 ms after relay 1 is switched, relay 2 opens to trigger reserve tie circuit breaker ("*back-up device*").

DI4: Relay feedback to monitor the interface switch status

1. Connect feedback contact to connection terminals DI4 and GND.
2. After commissioning: Configure "Relay loop-back" setting.

8.3 Digital_output_ "inverter off"

Country settings: "Germany", "IT-CEI021", "User Defined"

Output signal: Status "On": 12 V clocked, status "Off": 0 V.



NOTE

The digital output can only be used with suitable KACO inverters. When using devices from other manufacturers or in combination with KACO inverters, external interface switches must be used.

CAUTION

Equipment damage on short circuit

Destruction of the device if the digital output is short circuited.

- › Do not short circuit the digital output.

1. Connect wire A (+) to the terminal marked "EVU+" on the first inverter via the "DO1" terminal on the first inverter (see Figure 12).
2. Connect wire B (-) to the terminal marked "EVU-" on the first inverter via the "GND" terminal of the first inverter (see Figure 12).
3. Connect the other inverters to one another as follows:
 - Wire A (+) to wire A (+) and
 - wire B (-) to wire B (-).

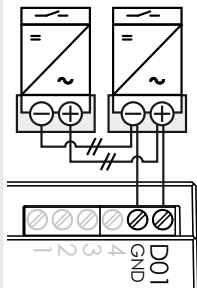

Figure 12: Digital output

8.4 RS485 Bus

NOTE



Ensure that the DATA+ and DATA- wires are properly connected. Communication is not possible if the wires are reversed!

NOTE



Different manufacturers do not always interpret the standard on which the RS485 protocol is based in the same way. Note that the wire designations (DATA+ and DATA-) for wires A and B may vary from one manufacturer to another.

8.4.1 Specification

Properties of the RS485 data line	
Maximum length of the RS485 bus line	The bus is permitted to be a maximum of 1200m long. This length can be reached only under optimum conditions. Cable lengths exceeding 500m generally require a repeater or a hub.
Maximum number of bus subscribers	32
Data line	Twisted, shielded. Recommendations: LI2YCYv (Twisted Pair) black for laying cable outside and in the ground, 2 x 2 x 0.5 LI2YCY (Twisted Pair) grey for dry and moist indoor spaces, 2 x 2 x 0.5

8.4.2 Connecting the RS485 bus



NOTE

☞ To prevent interference during data transmission:

- Observe the wire twisted pairing when connecting DATA+ and DATA- (see Figure 13)
- Do not lay RS485 bus lines in the vicinity of live DC/AC cables.

1. Connect the connection cable to the corresponding connection terminals.
2. Connect in this manner to all bus subscribers
 - Wire A (-) to wire A (-) and
 - Wire B (+) with wire B (+).
 Optional: Place screen of the connection cable on terminal GND.
3. If terminal unit: activate the terminating resistor.



Figure 13: Wire twisted-pair connection



NOTE

When using compatible inverters, the RS485 cabling can also be laid via the RJ45 socket to the underside of the device. The connection terminals can also be used together with the RJ45 socket, for example with combined use of Powador-protect, inverters with RJ45 socket and proLOG.

8.4.3 Activate connection resistance (optional)

Activate the terminating resistor if the Powador-protect represents the terminal unit within your wiring layout. Jumpers are included with the device for this purpose.

Applications	Connection assignment	Jumpers
Case 1: Terminal, RS485 master		

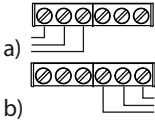
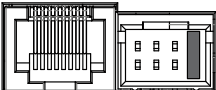
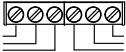
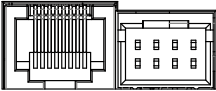
Applications	Connection assignment	Jumpers
☞	Insert 3 jumpers in accordance with diagram.	
Case 2: Terminal, RS485 slave	 <p>a)</p> <p>b)</p>	
☞	Insert jumpers in accordance with diagram.	
Case 3: Bus subscriber, slave		
☞	Do not insert jumpers.	

8.5 Fitting the ferrite clip

1. Place the ferrite clip supplied around the connection leads for ripple control receiver and/or digital output.
2. Close the ferrite clip.

9 Starting up the Powador-protect

9.1 Switching on Powador-protect

- ☞ The device has been mounted and electrically installed.
1. Connect the AC power supply and AC measurement inputs via external fuse elements.
 2. Start up the PV system in line with the installation instructions.
 - » The device begins the grid monitoring process and connects the PV system when the limit values are observed.

9.2 Sealing the Powador-protect (optional)

- ⤷ The device is mounted, electrically installed and configured.
- 1. Close the device cover.
- 2. Run sealing wire through the opening on the device cover and fit a closure.

9.3 Performing a self test

The Powador-protect supports the testing of the tripping circuit "NA protection - interface switch" in accordance with VDE AR-N 4105 in the "Germany" country setting. The digital output "Inverter off" and any connected interface switches are actuated.

- ☞ Press and hold the test button (>1s).
- » The self test is carried out. The "Processing manual event..." message appears on the display.
- » The device begins grid measurement and re-connects the PV system according to the waiting time set "Tstart".

10 Configuration and Operation

10.1 Text display

The text display shows measured values and data and allows the configuration of the device via a menu. In normal operation, the backlighting is switched off. When you press one of the three control buttons, the backlighting is activated. If no button is pressed for a period of time, it switches off again. Even if the device is sealed, you can press the Forward button through an opening in the cover using a sharp object.

10.2 LEDs



























Three LEDs on the front of the device show the different operating states. The LEDs can display the following states:

 LED on

 LED flashing



 LED off

The LEDs show the following operating states:

Operating status	LEDs	Description
Device off	<ul style="list-style-type: none">	<ul style="list-style-type: none">The device is not in operation.No LED is lit.The relay contacts are open.
Start	<ul style="list-style-type: none">	<ul style="list-style-type: none">The device starts up.The green "Operating" LED flashes.The relay contacts are open.
Operation	<ul style="list-style-type: none">	<ul style="list-style-type: none">The start process is ended.The green "Operating" LED is lit.The relay contacts are open.
Wait for connection	<ul style="list-style-type: none">	<ul style="list-style-type: none">The device monitors the grid and connects the PV system according to the waiting time set (T_{start}).The relay contacts are open.The green "Operating" LED is lit.The green "Relay closed" LED flashes.
Normal operation	<ul style="list-style-type: none">	<ul style="list-style-type: none">The relay contacts are closed.The green LEDs "Operating" and "Relay closed" are lit.
Fault	<ul style="list-style-type: none">	<ul style="list-style-type: none">The relay contacts are open.The green "Operating" LED is lit.The red "Fault" LED is illuminated.

10.3 Operating the device

Operation is carried out via 3 buttons to the right of the LC display.

Key	Function
 Forward button	Navigation within the menu structure
 Action button	Activate and exit the setting mode, change settings
 TEST Test button	Short button press (<1s): Activation of the temporary RS485 slave mode (only used by KACO-Service). Long button press (>1s): Initiate self test

Menu level 1

- » Menu level 1 is active by default and displays settings and status messages.

Open menu level 2

- ↻ Menu level 1 must be active.
- ☞ Press Action and Forward buttons simultaneously.
- » Menu level 2 is opened.

Open menu level 3

- ↻ Menu level 1 must be active.
- 3. Press and hold Action button for 20 seconds.
- 4. Enter password if required.
- » Menu level 3 is opened.

Carry out settings (via menu levels 2 and 3 only)

- ↻ The LCD shows menu level 2 or 3.
1. Press the Action button to access setting mode.
 - » The cursor appears underneath the first adjustable setting.
 2. If the menu option includes multiple adjustable settings, press the Forward button as necessary to select the setting to be changed.
 3. Press or hold down the Action button until the required setting value is reached.
 4. After running through all setting options, press the Forward button again to exit setting mode. When pressing the Forward button again, the next menu option will be displayed.

Save settings and exit menu (menu levels 2 and 3 only)

- ☞ Press Action and Forward buttons simultaneously.

10.4 Menu structure

Icons used:



Display menu



Password-protected menu



Settings menu















NOTE

The menu structure differs depending on the country of use selected in the "Country" setting.

The device hides the menu options not available in the selected country.

Menu level 1

Shows measurements, country setting, software version and recorded events. Each menu option is displayed for 2 seconds. After a complete menu run-through, the displays begins again from the start, beginning with the product name.

Display	Action in this menu/meaning
System starting...	 Displayed when the device starts up
Powador-protect	 Product name
SW version	
Boot version	 Software versions of the individual components
CFG version	
Serial number	 Unit serial number
Power control	 Control level of the external active power limitation
U L1, L2, L3	 Currently on L1, L2, L3 rated voltage
F	 Currently measured grid frequency
Country	 The country currently set
Current time	 Date and time
Log 01...Log 10	 Displays, if present, a maximum of the 10 last events recorded, with the time of occurrence















NOTE









The display of the voltages measured on L1, L2 and L3 may vary from the actual voltages present.

The function of shutdown in the event of an undervoltage or overvoltage fault is not affected.

Menu level 2

Display and change of non-critical system settings.











Display	Action in this menu/meaning
RS485 role	Set role of the Powador-protect in the RS485 bus Master: no proLOG is used,  Powador-protect is the terminal unit Slave: proLOG is used, Powador-protect is bus subscriber or terminal unit Observe the bus termination!
RS485 address	 Assign unique RS485 bus address (1...31)
U_{nom}	 Nominal voltage of the monitored public power grid 
$U>$: val, Toff	 Limit value voltage increase protector and trigger delay time for level 1/level 2 shutdown
$U>>$: val, Toff	 Limit value voltage increase protector and trigger delay time for level 1/level 2 shutdown
UR>	 Reconnection threshold after overvoltage shutdown
$U<$: val, Toff	 Limit value voltage drop protector and trigger delay time for level 1/level 2 shutdown
$U<<$: val, Toff	 Limit value voltage drop protector and trigger delay time for level 1/level 2 shutdown
UR<	 Reconnection threshold after undervoltage shutdown
$U10M>$: val, Toff	 Limit value voltage increase protector for shutdown due to 10-minute mean value
$F>$: val, Toff	 Limit value frequency increase protector and trigger delay time for level 1/level 2 shutdown
$F>>$: val, Toff	 Limit value frequency increase protector and trigger delay time for level 1/level 2 shutdown













Display	Action in this menu/meaning
FR>	Reconnection threshold after overvoltage shutdown
F<: val, Toff	 Limit value frequency drop protector and trigger delay time for level 1/level 2 shutdown
F<<: val, Toff	
FR<	 Reconnection threshold after underfrequency shutdown
Tstart	 Time of grid monitoring up to connection after device restart (in s)
Twait	 Time of grid monitoring up to re-connection after fault triggering (in s)
Realtime clock	 Set the date and time. NOTE: Date and time are buffered for a short period only on voltage loss. To obtain reliable fault and operating status messages, ensure that the date and time are correctly set at all times. In RS485 slave mode, the device obtains the current time from the RS485 master.
Remote tripping	 Status of the remote shutdown
Inv-off signal	 Status of the shutdown signal "Inverter off"
Relay loop-back	 Status of the feedback contact
Selftest start	 Start self test





Menu level 3



Display and change of critical system settings.

Observe the grid operator guidelines. Non-compliance may result in the operating permit being revoked.

Display	Action in this menu/meaning
Set&Enb Password	 Set password (4 characters 0...9, A...F) for access to menu level 3  NOTE: Password protection is optional.
Pwr-Ctr active	A ripple control receiver is connected.  Yes: Activated Power Control (power reduction by the power supply company) No: Deactivates the function
Pwr-Ctr DIx=1	
Pwr-Ctr DI2=1	 If Pwr-Ctr active=Yes: Set control power (in %) to apply when there
Pwr-Ctr DI3=1	 is a signal present on the corresponding digital input (DI1...DI4)
Pwr-Ctr DI4=1	
Pwr-Ctr All DI=0	 If Pwr-Ctr active=Yes: Set control power (in %) to apply when there is no signal present on any of the 4 digital inputs
Country	Set country of use.  Observe guidelines that apply at the installation site!
2-stage params	Enable:  Permit setting of the shutdown limits for shutdown level 2

Display	Action in this menu/meaning
U>: val, Toff	 Set limit value voltage increase protector and trigger delay time for level 1/level 2 shutdown
U>>: val, Toff	
UR>	 Set reconnection threshold after overvoltage shutdown
U<: val, Toff	 Set limit value voltage drop protector and trigger delay time for level 1/level 2 shutdown
U<<: val, Toff	
UR<	 Set reconnection threshold after undervoltage shutdown
U10M>: val, Toff	 Set limit value voltage increase protector for shutdown due to 10-minute mean value
F>: val, Toff	 Set limit value frequency increase protector and trigger delay time for level 1/level 2 shutdown
F>>: val, Toff	
FR>	 Set reconnection threshold after overfrequency shutdown
F<: val, Toff	 Set limit value frequency drop protector and trigger delay time for level 1/level 2 shutdown
F<<: val, Toff	
FR<	 Set reconnection threshold after underfrequency shutdown
Tstart	 Time of grid monitoring up to connection after device restart (in s)
Twait	 Time of grid monitoring up to re-connection after fault triggering (in s)
Clear log	 "Yes": delete saved log data "No": no action

Display	Action in this menu/meaning
U_{nom}	 Set nominal voltage of the monitored public power grid
Connection-cond.	<p>Enable: Activate monitoring of the reconnection thresholds for over/undervoltage and over/underfrequency.</p> <p>Disable:  Deactivate monitoring of the reconnection thresholds for over/undervoltage and over/underfrequency for 3 hours. Connection takes place as long as the shutdown threshold has not been exceeded.</p>
1-stage params	<p>Enable: Activate monitoring of shutdown limits level 1</p> <p>Disable:  Deactivate monitoring of the shutdown limits level 1 for under/overvoltage and over/underfrequency for 3 hours. Set shutdown limits of level 1 are ignored.</p>
Remote tripping	<p> "Active high": The "Remote shutdown" function becomes active when digital input DI1 (RMT) is connected to GND.</p> <p>"Active low": The "Remote shutdown" function becomes active when digital input DI1 (RMT) is open.</p>

Display	Action in this menu/meaning
Inv-off signal	 <p>"Interface switch": Digital output DO1 switches the connected inverters off when relay 1 opens.</p> <p>"Backup device": Digital output DO1 switches the connected inverters off when relay 2 opens.</p>
Relay loop-back	 <p>"Active high": The interface switches are closed when digital input 4 (IFS) is connected to GND.</p> <p>"Active low": The interface switches are closed when digital input 4 (IFS) is open.</p>

11 Maintenance/Troubleshooting

11.1 Visual inspection

Inspect the device and the cables for visible external damage and note the operating status display. In case of damage, notify your installer. Repairs may only be carried out by an electrician.



NOTE

The device should be checked for proper operation by a qualified electrician at regular intervals.

11.2 Procedure in the event of a fault



DANGER

Lethal voltages are present in the terminals and cables in the device!



Severe injury or death may occur if the cables and terminals are touched.

- ☞ When a fault occurs, notify an appropriately authorised and qualified electrician or KACO new energy GmbH Service.
-

- ☞ In case of a grid failure, wait for the system to automatically restart.
 - ☞ Notify your electrician if there is an extended power failure.
-



11.3 Troubleshooting

Fault	Cause	Rectification
The display is blank and the LEDs are not lighting up.		
↻	Grid voltage not available.	
☞	Check whether the AC voltages are within the permitted limits (see Technical Data).	
☞	Have the cables and fuses checked by a qualified electrician.	
☞	If necessary, notify KACO service.	
The device has shut off the PV system from the grid.		
↻	The green "Relay connected" LED is off.	
↻	The red "Fault" LED is illuminated.	
1.	Check the status and fault signals.	
2.	Determine the fault category:	
☞	Grid errors: wait for re-connection of the system. Where necessary have the cables and fuses checked by an electrician.	
☞	Internal error: Notify KACO Service.	
No access to settings on menu level 3.		
↻	The device is password protected.	
☞	Enter the password.	
☞	If unknown: Notify KACO Service.	

11.4 Status and fault signals

On the device, the last 10 recorded fault or operating status messages (Log 1 ... Log 10) with date and time of occurrence are automatically displayed in menu level 1 on the display. The following table gives the possible fault and operating status messages that the

device shows via the LC display and signalled visually via the "Fault" LED.

In the event of a fault:   The red "Fault" LED is illuminated.

↩ Event ↻ Cause

Line error

Display	Fault description
F>/F>>	Shutdown due to exceedance of the frequency increase protector level 1/level 2
F</F<<	Shutdown due to lower deviation of the frequency drop protector level 1/level 2
LNx_U>/LNx_U>>	Shutdown due to exceedance of the voltage increase protector level 1/level 2 on phase x
LNx_U>/LNx_U>>	Shutdown due to lower deviation of the voltage drop protector level 1/level 2 on phase x
LL12_U>/LL12_U>> LL23_U>/LL23_U>> LL31_U>/LL31_U>>	Shutdown due to exceedance of the voltage increase protector level 1/level 2 between phases L1-L2/L2-L3/L3-L1
LL12_U</LL12_U<< LL23_U</LL23_U<< LL31_U</LL31_U<<	Shutdown due to lower deviation of the voltage drop protector level 1/level 2 between phases L1-L2/L2-L3/L3-L1
LNx_U10M>	Shutdown due to exceedance of the voltage increase protector level 1/level 2 on phase x (10-minute mean value)
TEST	Button for manual fault triggering has been activated

System fault	
Display	Fault description
RELAYS	Interface switch faults: when reading the relay contacts for the single fault proof assurance, it was detected that the relay has not been activated
Internal fault	
Display	Fault description
VOLTRDC	Internal fault: Difference between the voltage measurement of the 3 phases and the redundant voltage measurement for the single fault proof assurance
VREF15	Internal fault: in the A/D converter check with reference voltage for single fault proof assurance, a fault was detected

12 Warranty and Service

12.1 Factory warranty and liability

On our website <http://www.kaco-newenergy.de/> you will find our latest warranty conditions and a complaints form, in addition to more detailed information.

During the warranty period, KACO new energy GmbH guarantees the proper function of the unit and to undertake repairs at the factory free of charge in the event of a defect for which we are responsible.

Contact your specialist dealer if your unit exhibits a defect or fault during the warranty period.

Warranty claims are excluded in the following cases:

- Use of the unit in ways not intended
- Improper installation or installation that does not comply with standards

- Improper operation
- Open the housing (housing cannot be opened without damage)
- Operating the unit with defective protective equipment
- Unauthorised modifications to the units or repair attempts
- Influence of foreign objects or force majeure (lightning, overvoltage, severe weather, fire)
- Failure to observe the relevant safety regulations
- Transport damage

All warranty claims must be handled at the premises of KACO new energy GmbH. Where possible, the unit must be returned in its original or equivalent packaging. The costs for these services cannot be borne by KACO new energy GmbH.

KACO new energy GmbH will only perform warranty services if the defective unit is returned to KACO new energy GmbH together with a copy of the invoice which was issued to the user by the dealer. The name plate on the unit must be fully legible. If these requirements are not fulfilled, KACO new energy GmbH reserves the right to deny warranty services.

12.2 Service

If you need help fixing a technical problem with one of our KACO products, please contact our service department

Telephone: +49(0)7132-3818-690

Email: service@kaco-newenergy.de

So that your enquiry can be dealt with more quickly, please always have the serial number of the device. This can be found on the name plate on the right of the housing.

13 Disposal

For the most part, both the Powador-protect and the corresponding transport packaging are made from recyclable raw materials.

13.1 Unit

Defective units must not be disposed of with household waste. Ensure that the old unit and any accessories are disposed of in a proper manner.

13.2 Packaging

Ensure that the transport packaging is disposed of properly.

14 EU Declaration of Conformity

Manufacturer's name and address	KACO new energy GmbH Carl-Zeiss-Straße 1 74172 Neckarsulm, Germany
Product description	External grid and system protection
Type designation	Powador-protect

This is to confirm that the unit stated above is compliant with the protection requirements set forth in Directive 2014/30/EC of the European Parliament and of the Council of 26 February 2014 on the approximation of the laws of the Member States relating to electromagnetic compatibility (Electromagnetic Compatibility Directive) and Directive 2014/35/EC (Low Voltage Directive).

The device is compliant with the following standards and guidelines:

2014/35/EU

"Directive relating to electrical equipment designed for use within certain voltage limits"

2014/30/EU

"Directive relating to electromagnetic compatibility"

Safety of the unit

EN 61010-1:2010

Interference immunity

EN 61000-6-2:2005

Emitted interference

EN 61326-1:2006

Secondary effects on the grid

EN 61000-3-2:2006+A1.2009+A2.2009

EN 61000-3-3:2008

The product mentioned above is therefore labelled with the **CE marking**.

Unauthorised modifications to the supplied units and/or any use of the units that is contrary to their intended use render this Declaration of Conformity null and void.

A handwritten signature in blue ink, appearing to read 'M. Haag', is positioned on the left side of the page.

Neckarsulm, 20/04/2016
KACO new energy GmbH

p.p. Matthias Haag
Member of the management
team for technology

K A C O



new energy.

Carl-Zeiss-Straße 1
74172 Neckarsulm
Germany

Tel. +49 7132 3818-0

Fax +49 7132 3818-703

info@kaco-newenergy.de

www.kaco-newenergy.de



3008096-02-161011