



KACO 
new energy.

KACO blueplanet 3.0 NX1 M2
KACO blueplanet 3.7 NX1 M2
KACO blueplanet 4.0 NX1 M2
KACO blueplanet 5.0 NX1 M2

Manual

- English translation of German original

 **Authorised electrician**
Important safety instructions



Android APP



iOS APP



Installation video
3.0-5.0 NX1



Start-up video via APP

Legal provisions

The information contained in this document is the property of KACO new energy GmbH. Publication, in whole or in part, requires the written permission of KACO new energy GmbH.

KACO warranty

You can download the current warranty conditions from the Downloads folder on our website at <http://www.kaco-newenergy.com>.

Definitions on product designations

In this manual, the product “Photovoltaic feed-in inverter” is referred to as the device for ease of reading.

Trademarks

All trademarks are recognised, even if not explicitly identified as such. A lack of identification does not mean that a product or designation/logo is free of trademarks.

Software

This device contains open source software developed by third parties and in some cases licensed under GPL and/or LGPL. More details on this topic and a list of the open source software used, as well as the corresponding licence texts, can be found on the associated “**KACO NX Setup**” APP in the “Info” menu under “Imprint”, “Wi-Fi Stick Licences” and “Mobile APP Licences”.

Photovoltaic feed-in inverter

Table of contents

1	General information	1	8	Commissioning	23
1.1	Notes regarding this document.....	1	8.1	Requirements	23
1.2	More information.....	1	8.2	Preconditions relating to standards	23
1.3	Layout of Instructions.....	1	9	Configuration and operation	24
1.4	Target group.....	2	9.1	Start condition.....	24
1.5	Marking	3	9.2	Initial start-up.....	24
2	Safety	4	9.3	Authorisation.....	25
2.1	Intended use	4	9.4	Operating system and system configuration....	26
2.2	Protection features	5	9.5	Signal elements	27
3	Description of the device.....	6	9.6	Connecting to the device.....	28
3.1	Mode of operation	6	9.7	Menu of the Communication unit.....	31
3.2	System layout.....	6	9.8	Additional functions	34
4	Technical data	7	9.9	Menu of Inverter	37
4.1	Electrical data	7	9.10	Operation mode	38
4.2	General data.....	8	9.11	Enabling functions.....	39
4.3	Environmental data.....	8	9.12	Performing a firmware update.....	49
4.4	Accessories	8	9.13	Monitoring with “blueplanet web”	51
5	Transportation and Delivery	9	9.14	Monitoring the device	52
5.1	Scope of delivery	9	9.15	Active power control with a Smart-Meter	52
5.2	Transporting the device	9	9.16	Information on dynamic feed-in	52
5.3	Installation tool	9	10	Maintenance and troubleshooting	55
6	Assembly and preparation.....	10	10.1	Visual inspection.....	55
6.1	Choosing the installation location.....	10	10.2	Cleaning	55
6.2	Unpacking the device	11	10.3	Shutting down for maintenance work / troubleshooting.....	56
6.3	Fastening the mount	12	10.4	Troubleshooting	57
6.4	Installing and securing the device	13	10.5	Error code.....	57
7	Installation	14	10.6	Fault during connection set-up and search.....	60
7.1	General information	14	10.7	Disconnecting connections.....	61
7.2	Surveying the connection area.....	14	11	Decommissioning and dismantling	62
7.3	Making the electrical connection	15	11.1	Switching off the device	62
7.4	Connecting the device to the power grid.....	15	11.2	Uninstalling the device	62
7.5	Connecting the PV generator to the device	17	11.3	Disassembling the device	63
7.6	Creating equipotential bonding	20	11.4	Packaging the device	63
7.7	Connecting the interfaces	20	11.5	Storing the device.....	63
7.8	Connecting the Smart-Meter for dynamic feed-in	21	12	Disposal.....	63
			13	Service and warranty.....	63
			14	Appendix.....	64
			14.1	EU Declaration of Conformity	64

1 General information

1.1 Notes regarding this document



WARNING

Improper handling of the device can be hazardous!

› You must read and understand the manual in order to install and use the device safely.

Other applicable documents

During installation, observe all assembly and installation instructions for components and other parts of the system. These instructions also apply to the device, associated components and other parts of the system.

Some of the documents required for the registration and approval of your system are included with the manual.

Retention of documents

This manual and other document must be stored near the system and be available at all times.

- The current version of the manual can be downloaded from www.kaco-newenergy.com.

Original version

This document has been produced in several languages. The German version is the original version. All other language versions are translations of the original version.

1.2 More information

Links to more detailed information can be found at www.kaco-newenergy.com.

Document title	Document type
Technical data sheet	Product flyer
Dynamic feed-in limitation and blueplanet web with/without data logger	Application Notes
Firmware package	Zip file
Software	Automatic update for iOS / Android app
EU Declaration of Conformity	Certificates
Country-specific certificates - Certification for specific subassemblies	Certificates

1.3 Layout of Instructions

1.3.1 Symbols used



General hazard



Fire and risk of explosion



Electrical voltage



Risk of burns



Earthing - ground conductor

1.3.2 Safety warnings symbols guide



DANGER

High risk

Failure to observe this warning will lead directly to serious injuries or even death.



WARNING

Potential risk

Failure to observe this warning may lead to serious injuries or even death.



CAUTION

Low-risk hazard

Failure to observe this warning will lead to minor or moderate injuries.

NOTE

Risk of property damage

Failure to observe this warning will lead to property damage.

1.3.3 Additional information symbols



NOTE

Useful information and notes

Information that is important for a specific topic or objective, but that is not safety-relevant.

1.3.4 Symbols for instructions

 Prerequisite for use.

1 Perform next step

2 Additional action sequence

⇒ Interim result of the action

» End result

1.4 Target group

All activities described in the document may only be carried out by skilled personnel who have the following qualifications:

- Knowledge about how an inverter functions and operates.
- Training in the handling of hazards and risks during the installation and operation of electrical devices and systems.
- Education concerning the installation and start-up of electrical devices and systems.
- Knowledge of applicable standards and directives.
- Knowledge and adherence to this document with all safety notices.

1.5 Marking

You will find the name plate with the following data for service and other requirements specific to installation on the right side panel of the product:

- Product name
- Part number
- Serial number
- Date of manufacture
- Technical details
- Disposal information
- Certification marking, CE marking.





 KACO new energy Werner-von-Siemens-Allee 1 74172 Neckarsulm		blueplanet 5.0 NX1 M2 WM OD I190		
		Part number 1002018		
		Serial number 5.0NX12000001	Year Q1 / 21	
				
Input	Vmax PV / Isc PV(max) / Inom PV	580 V / 2x18 A / 2x 12 A		
	V- MPP at Pnom / V- range	220 V - 480 V / 80 V - 550 V		
Output	Nominal voltage	220 V (1/N/PE)		
		230 V (1/N/PE)		
		240 V (1/N/PE)		
	Voltage range continuous operation	180 Vac - 290 Vac		
Output Power	Current(maximum continuous)	22.7 A		
	Frequency range	45 Hz - 65 Hz		
	Snom at 230 V Unom	5000 VA		
	Reactive power	0 - 60% Snom	cos phi	0.8 - 0.8 ind/cap
Environ-ment	Temperature range	-25°C...+60°C/ -13°F...+140°F		
	Protection class / Ingress protection	I / IP65		
No galvanic separation / Ungrounded Arrays Only		Max. Backfeed Current	0	
Grid Support Interactive Inverter		ARC fault circuit protection	none	
Interface protection according to country specific requirements, details see manual				
				
				

Fig. 1. Name plate

2 Safety

DANGER

Lethal voltages are still present in the connections and cables of the device even after the device has been switched off and disconnected!

Coming into contact with the lines and/or terminals/busbars in the device can cause serious injury or death.



- › Do not open the device.
- › The device must be mounted in a fixed position before being connected electrically.
- Comply with all safety regulations and current technical connection specifications of the responsible power supply company.
- › The device is only permitted to be mounted, installed and commissioned by a qualified electrician.
- › Switch off the grid voltage by turning off the external circuit breakers.
- › Do not touch the cables and/or terminals/busbars when switching the device on and off.
- › Check that all AC and DC cables are completely free of current using a clip-on ammeter.

The electrician is responsible for observing all existing standards and regulations. The following points must be taken into account:

- Keep unauthorised persons away from the device and/or system.
- In particular, observe standard¹ “Requirements for special types of premises, rooms and installations - Solar photovoltaic (PV) power supply systems” in the respective regionally applicable version
- Ensure operational safety by providing proper grounding, conductor dimensioning and appropriate protection against short circuiting.
- Observe all safety instructions on the product and in these operating instructions
- Switch off all voltage sources and secure them against being inadvertently switched back on before performing visual inspections and maintenance.
- When taking measurements on the live device:
 - Do not touch the electrical connections
 - Remove all jewellery from wrists and fingers
 - Ensure that the testing equipment is in safe operating condition
- Modifications to the surroundings of the device must comply with the applicable national and local standards

2.1 Intended use

The device is a transformerless PV inverter which converts the direct current of the PV generator into grid-compatible single-phase alternating current and then feeds the single-phase alternating current into the public power grid.

The device is built using state-of-the-art technology and in accordance with the recognized safety rules. Nevertheless, improper use may cause lethal hazards for the operator or third parties, or may result in damage to the product and other property.

The device is intended for indoor and outdoor applications and may only be used in countries for which it has been approved or for which it has been released by KACO new energy and the grid operator.

Operate the device only with a permanent connection to the public power grid. The country and grid type selection must be commensurate with the respective location and grid type.

The requirements of the grid operator must be met for grid connection to take place. The permission of the relevant authorities may also be required in order to secure authorisation to connection to the grid.

The device may only be operated with PV arrays (PV modules and wiring) of protection class II pursuant to IEC 61730, application class A.

The enclosed documentation is an integral part of the product. The documentation must be read, observed and stored in a place which is freely accessible at all times.

1	Country	Standard
	EU	Harmonised document - HD 60364-7-712 (European implementation of the IEC standard)

The name plate must be permanently attached to the product.

Any other or additional use of the device shall be regarded as improper. This includes:

-
- Use of a distribution system that is not described (grid type)
 - Use of sources other than PV-strings
 - Mobile use
 - Use in rooms where there is a risk of explosion
 - Use in direct sunlight, rain or a storm or other harsh environmental conditions
 - Use in an outdoor area that does not meet the environmental conditions set down in Technical Data > Environmental Data.
 - Operation outside the specification intended by the manufacturer
 - Overvoltage on the DC connection of over 580 V
 - Modifying the device
 - Standalone mode

2.2 Protection features

The following monitoring and protection functions are built-in:

- System for monitoring the device temperature
- EMC filters to protect the inverter from high-frequency grid interference
- Anti-islanding detection according to the current standards.
- Isolation detection / residual current monitoring and disconnection function to detect isolation faults

3 Description of the device

3.1 Mode of operation

The device converts the DC voltage generated by the PV-modules into AC voltage and feeds this into the power grid. The starting procedure begins when there is sufficient sunlight and a specific minimum voltage is present in the device. The feed-in process begins once the PV generator has passed the insulation test and the grid parameters are within the requirements imposed by the grid operator for a specific monitoring time. If, as it gets dark, the voltage drops below the minimum voltage value, feed-in mode ends and the device switches off.

3.2 System layout

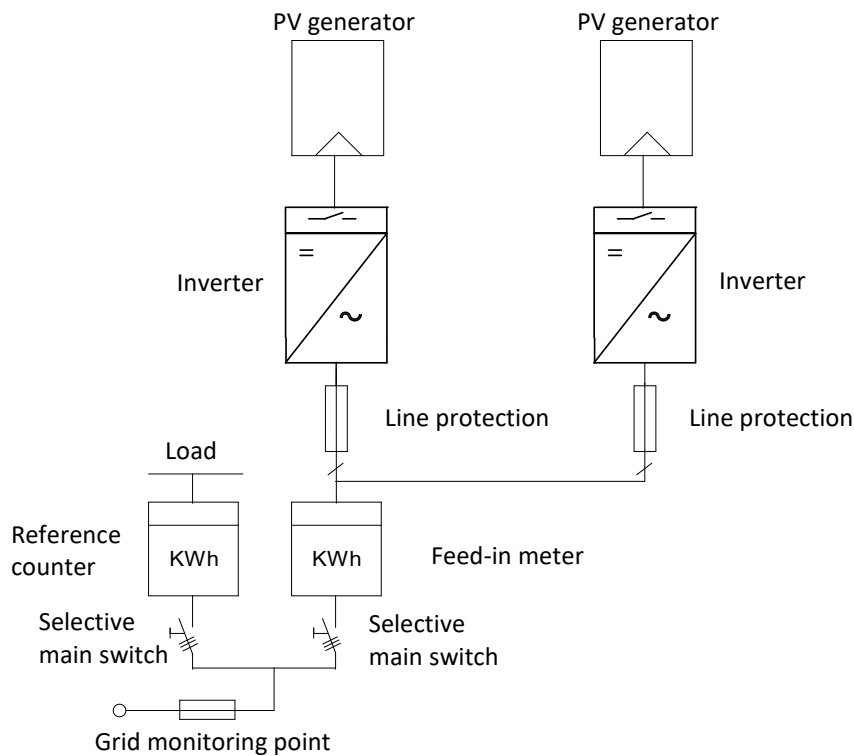

Fig. 2. Circuit diagram of a system with two inverters

Key	Definition / information on the connection
PV generator	The PV generator converts the radiant energy of sunlight into electrical energy.
Inverter	The PV generator is connected to the device's DC connection.
Line protection	The circuit breaker is an overcurrent protection device.
Feed-in meter	The feed-in meter is to be specified and installed by the power supply company. Some power supply companies also allow the installation of your own calibrated counters.
Selective main switch	The selective main switch is to be specified by the power supply company.
Reference counter	The reference counter is to be specified and installed by the power supply company. This measures the amount of energy drawn.
Integrated DC isolator switch	Use the integrated DC isolator switch to disconnect the device from the PV generator.

4 Technical data

4.1 Electrical data

KACO blueplanet	3.0 NX1 M2	3.7 NX1 M2	4.0 NX1 M2	5.0 NX1 M2
DC Input levels				
Recommended generator power range	3.0 kW	3.68 kW	4.0 kW	5.0 kW
MPP range at nominal power	140-480 V	165-480 V	180-480 V	220-480 V
Working range	80-550 V			
Rated voltage	360 V	360 V	360 V	360 V
Starting voltage	80 V (PLC switch-on voltage, feed-in voltage is 100 V)			
No-load voltage	580 V			
Max. input current ²	2*12 A			
Number of strings	2			
Number of MPP controls	2			
Max. short-circuit current (I _{sc max.})	2 x 18 A			
Input source feedback current	0 A			
Polarity safeguard	yes			
String fuse	no			
DC overvoltage protection	no			
KACO blueplanet	3.0 NX1 M2	3.7 NX1 M2	4.0 NX1 M2	5.0 NX1 M2
AC Output levels				
Nominal power	3 kVA	3.68 kVA	4 kVA	5 kVA
Rated voltage	230 V [3/N/PE]			
Voltage range: continuous operation	180 V - 290 V			
Rated current	13 A	16 A	17.4 A	21.7 A
Max. continuous current	15 A	16 A	20 A	22.7 A
Contribution to peak short-circuit current i _p	48 A			
Initial short-circuit alternating current (I _k " first single period effective value)	34 A			
Make current	<20 % of the rated AC current for a maximum of 20 ms			
Rated frequency	50/60 Hz			
Frequency range	45 – 65 Hz			
Reactive power	0 - 60 % S _{nom}			
cos-phi	0.8 inductive.... 0.8 capacitive			
Number of feed-in phases	1			
Distortion factor (THD)	<3%			
Max. voltage range (up to 100 s)	295 V			
AC overvoltage protection	no			

² The "Max. input current" is the maximal theoretical value for operation with full power when the feed-in power is low. The inverter switches to the maximum AC output power.

The "Max. short-circuit current (I_{SCmax.})" together with the open circuit voltage (U_{OCmax}) defines the characteristic of the connected PV generator. This is the relevant value for string design and represents the absolute maximum limit for inverter protection. The connected PV generator must be designed in such a way that the maximum short-circuit current is less than or equal to the I_{SCmax} of the inverter under all foreseeable conditions. The design must in no case result in a short-circuit current greater than the I_{SCmax} of the inverter.

4.2 General data

KACO blueplanet	3.0 NX1 M2	3.7 NX1 M2	4.0 NX1 M2	5.0 NX1 M2
Max. efficiency	97.5%			
Europ. Efficiency	96.02%	96.33%	96.47%	96.70%
Self consumption: Standby	5 W			
Feed-in from	60 W			
Transformer unit	no			
Protection class / over voltage category	I / III (AC) II (DC)			
Grid monitoring	Country-specific			
Distribution system	TN-C-System, TN-C-S-System, TN-S-System, TT-System			
Display	LED			
Controls	no			
Menu languages	DE, EN			
Interfaces	Communication unit / RS485 (e.g. smart meter) (optional)			
Communication	WLAN			
Radio technology	WLAN 802.11 b / g / n			
Frequency spectrum	2,412 MHz - 2,472 MHz			
Antenna gain	2 dBi			
Potential-free relay	no			
DC isolator switch	yes			
AC isolator switch	no			
Cooling	natural			
Number of fans	no			
Noise emission	< 25 dB(A)			
Housing material	Aluminium			
HxWxD	355 mm * 376 mm * 145 mm			
Weight	11 kg			
Certifications	Overview: see website / download area			

4.3 Environmental data

KACO blueplanet	3.0 NX1 M2	3.7 NX1 M2	4.0 NX1 M2	5.0 NX1 M2
Installation height	3,000 m			
Installation distance from coast	3,000 m			
Ambient temperature	-25 °C ...+60 °C			
Power derating from	+40 °C			
Protection rating (KACO installation location)	IP65			
Humidity range (non-condensing) [%]	100%			

4.4 Accessories

Accessory articles	KACO order no.
NX1 smart meter connection kit	3015112
Eastron SDM230	3015113

5 Transportation and Delivery

Every product leaves our factory in perfect electrical and mechanical condition. Special packaging ensures that the devices are transported safely. The shipping company is responsible for any transport damage that occurs.

5.1 Scope of delivery

Article	Description	Quantity
A	Inverter	1 piece
B	Wall mounting bracket	1 piece
C	Mounting accessory kit: Wall fixings and hex bolts (3×) M4×10 mm screw (4×)	1 set
D	DC plug connector	2 pairs
E	AC connector	1 piece
F	Communication device (WiFi stick)	1 piece
G	Documentation	1 set

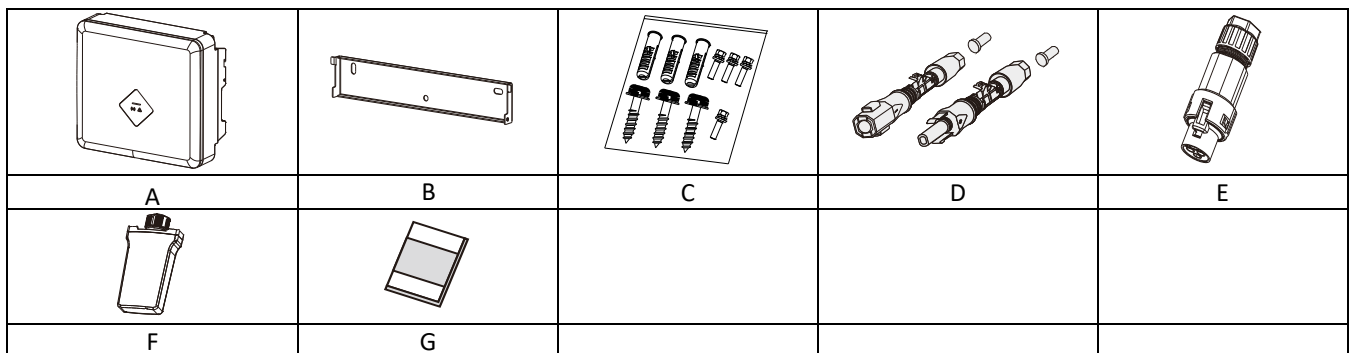

Check the equipment included

- Inspect the device thoroughly.
- Immediately notify the shipping company in case of the following:
 - o Damage to the packaging that indicates that the device may have been damaged.
 - o Obvious damage to the device.
- Send a damage report to the shipping company immediately.
- The damage report must be received by the shipping company in writing within six days following receipt of the device. We will be glad to help you if necessary.

5.2 Transporting the device

CAUTION



Hazard due to impact; risk of breakage to the device!

- › Pack the device securely for transport.
- › Transport the device using the intended carrying handles of the packaging box.
- › Do not expose the device to any shocks.

5.3 Installation tool

The codes given in the table below are used in all usage instructions for assembly/installation/maintenance and disassembly for the tools and tightening torques being used.

Code (s)	Shape of the connector
XW	External hexagon
XT	Torx
XS	Slot
XP	Phillips

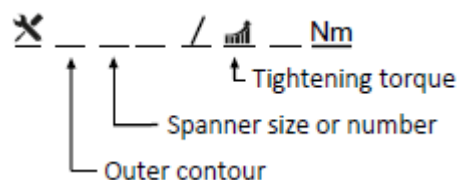

Fig. 3. Form pattern

6 Assembly and preparation

6.1 Choosing the installation location



DANGER

Risk of fatal injury due to fire or explosions!

Fire caused by flammable or explosive materials in the vicinity of the device can lead to serious injuries.

- › Do not mount the inverter in an area at risk of explosion or in the vicinity of highly flammable materials



CAUTION

Property damage due to gases that have an abrasive effect on surfaces when they come into contact with ambient humidity caused by weather conditions.

The device housing can be seriously damaged due to gases in combination with air humidity resulting from weather conditions (e.g. ammonia, sulphur).

- › If the device is exposed to gases, the installation must be carried out at observable locations.
- › Perform regular visual inspections.
- › Immediately remove any moisture from the housing.
- › Ensure adequate ventilation at the installation location.
- › Immediately remove dirt, especially on vents.
- › Failure to follow these warnings may result in damage to the device that is not covered by the manufacturer's warranty.



NOTE

Access by maintenance personnel for service

Any additional costs arising from unfavourable structural or installation conditions will be billed to the customer.

Installation space

- As dry as possible, climate-controlled. The waste heat must be dissipated away from the device
- Unobstructed air circulation
- When installing the device in a control cabinet, provide forced ventilation for sufficient heat dissipation
- Close to the ground, accessible from the front and sides without requiring additional resources
- In outdoor areas, protected on all sides from direct weather exposure and sunlight (thermal heating). Implementation where necessary via constructional measures, e.g. wind breaks
- Make sure that the inverter is installed out of the reach of children.
- To ensure an optimal operation and a long service life, the temperature of the installation environment of the inverter should be ≤ 40 °C.

Installation surface

- Must have adequate load-bearing capacity
- Must be accessible for installation and maintenance
- Must be made of heat-resistant material (up to 90 °C)
- Must be flame resistant
- Minimum clearances to be observed during installation [see Fig. 9 on Page 12]

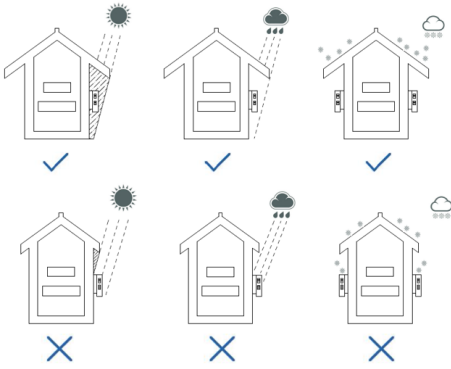

Fig. 4. Device for outdoor installation

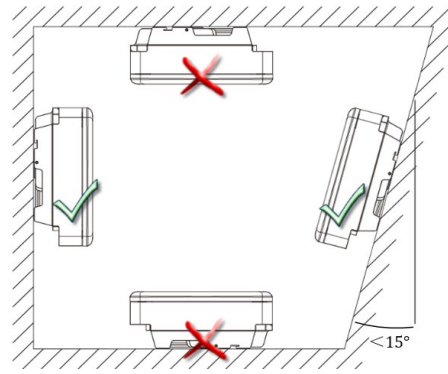

Fig. 5. Permissible installation location

6.2 Unpacking the device



⚠ CAUTION

Risk of injury due to excessive physical strain

Lifting the device, for transport, relocation and assembly can result in injuries (e.g. back injuries).

› Only lift the device using the grip recesses provided.

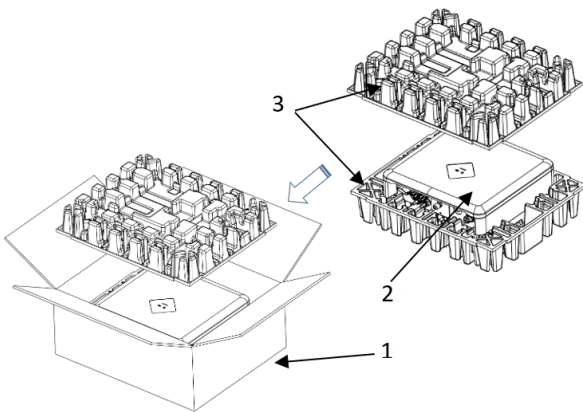

Fig. 6. Unpacking the device

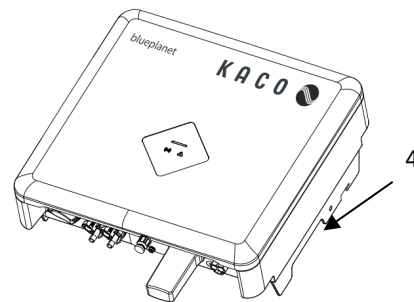

Fig. 7. Lift the unit

Key

1	Packaging box	3	Protective packaging
2	Device	4	Grip recesses

🔄 The device has been transported to the installation site.

1. Loosen packaging tape from cardboard box.
 2. Open carton at the front.
 3. Remove installation material and documentation.
 4. Pull up top protective packaging to remove.
 5. Remove device from the packaging.
 6. Place the protective packaging back into the packaging box.
 7. Lift the device at the intended positions.
- » Continue installing the mount.

6.3 Fastening the mount



CAUTION

Hazard when using unsuitable fixing materials!

If unsuitable fixing materials are used, the device could fall and persons in front of the device may be seriously injured.

- › Use only fixing materials that are suitable for the mounting base. The fastening materials supplied are only suitable for masonry and concrete.
- › Only install the device in an upright position.

NOTE



Power reduction due to heat accumulation!

If the recommended minimum clearances are not observed, the device may go into power regulation mode due to insufficient ventilation and the resulting heat build-up.

- › Observe minimum clearances and provide for sufficient heat dissipation.
- › All objects on the device housing must be removed during operation.
- › Ensure that no foreign bodies prevent heat dissipation following device installation.

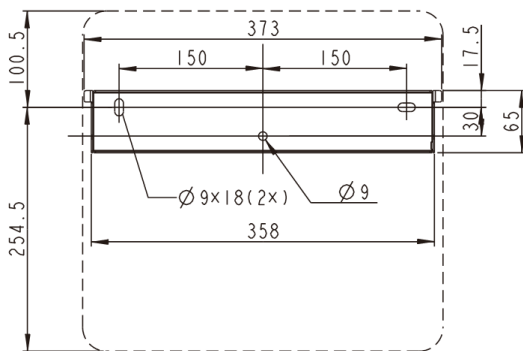

Fig. 8. Drill holes for wall mounting

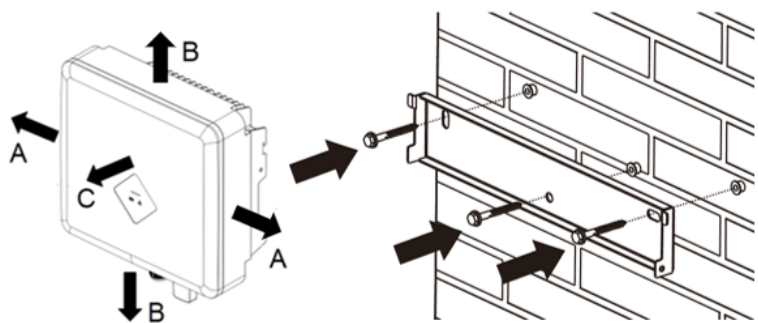

Fig. 9. Mounting the wall bracket

Key

1 Drill three holes [\varnothing 10 mm depth 70 mm]	5 Screw for securing purposes
2 Insert screws and anchors	A Minimum clearance: 300 mm
3 Take out the wall bracket	B Minimum clearance: 500 mm
4 Install the wall holder	C Minimum clearance: 500 mm

Cardboard packaging with mount and mounting kit removed from the packaging and opened.

1. Mark the mounting position on the wall surface according to the position of the mount plate by drawing three marks.
2. Mark the positions of the drill holes and drill three holes.

NOTE: The minimum clearances between two devices, or the device and the ceiling or floor have already been taken into account in the diagram.

3. Fix the mount to the wall using suitable mounting fixtures from the mounting kit [XW-10].

NOTE: Make sure that the mount is oriented correctly.

- › Proceed with the installation of the device.

6.4 Installing and securing the device

CAUTION





Risk of injury from improper lifting and transport.

If the device is lifted improperly, it can tilt and result in a fall.

- › Always lift the device vertically using the openings provided.
- › Use a climbing aid for the chosen installation height.
- › Wear protective gloves and safety shoes when lifting and lowering the device.

Lifting and installing the device

 The mount has been installed.

1. Lift the device using the recesses. Observe the centre of gravity!
2. Fit the device onto the mounting bracket. Check both sides of the heat sink to ensure that it is securely in place.
3. Insert the screw provided into the lug of the mount and secure the device to prevent it from being lifted off. [ P / 2 Nm]

NOTE: At this point, the screw described above can be replaced by a special screw as anti-theft protection.

» Device is installed. Proceed with the electrical installation.

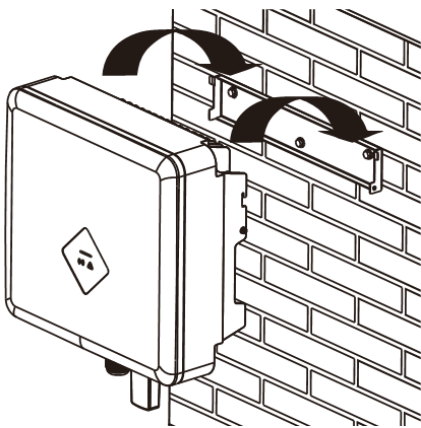

Fig. 10. Mount the inverter to the wall bracket

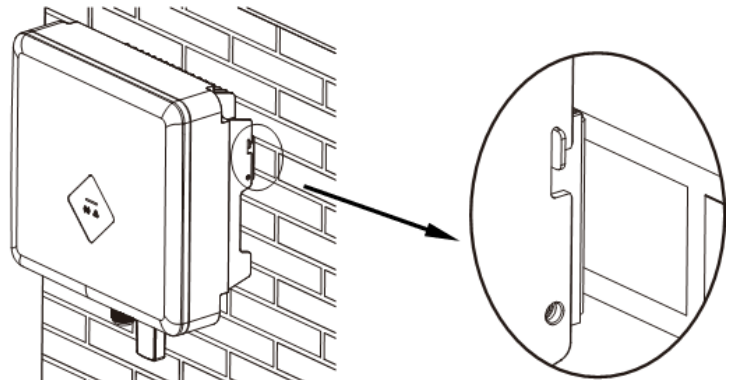

Fig. 11. Check the device is secure

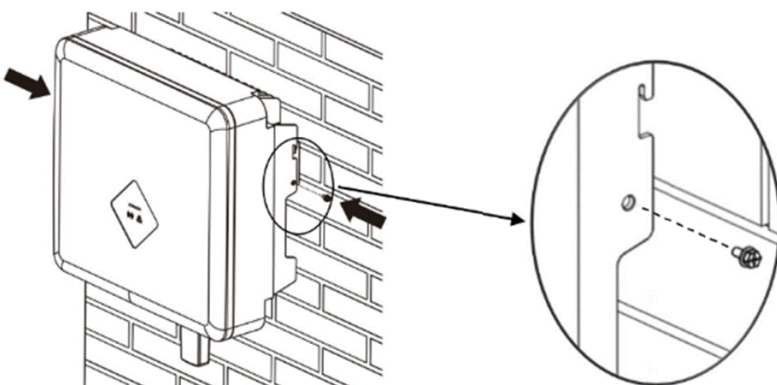

Fig. 12. Secure the inverter

⚠ CAUTION

Property damage as a result of condensation

During pre-assembly of the device, moisture can enter the internal space via the DC connectors and the dust-proof screw connections. The resulting condensate can cause damage to the device during installation and start-up.



- Keep the device closed during pre-assembly and do not open the connection area until you perform installation.
- Seal off any plug-in connections and screw fittings using sealing covers.
- Immediately remove any moisture from the housing.

7 Installation

7.1 General information

⚠ DANGER

Lethal voltages are still present in the connections and cables of the device even after the device has been switched off and disconnected!



Coming into contact with the lines and/or terminals/busbars in the device can cause serious injury or death.

- › Do not open the device.
- › The device must be mounted in a fixed position before being connected electrically.
- › Comply with all safety regulations and current technical connection specifications of the responsible power supply company.
- › Switch off the grid voltage by turning off the external circuit breakers.
- › Check that all AC and DC cables are completely free of current using a clip-on ammeter.
- › Do not touch the cables and/or terminals/busbars when switching the device on and off.

7.2 Surveying the connection area

The connection for the AC supply is located on the housing in the lower right area. The DC input source is connected to the DC plugs and DC sockets on the base plate.

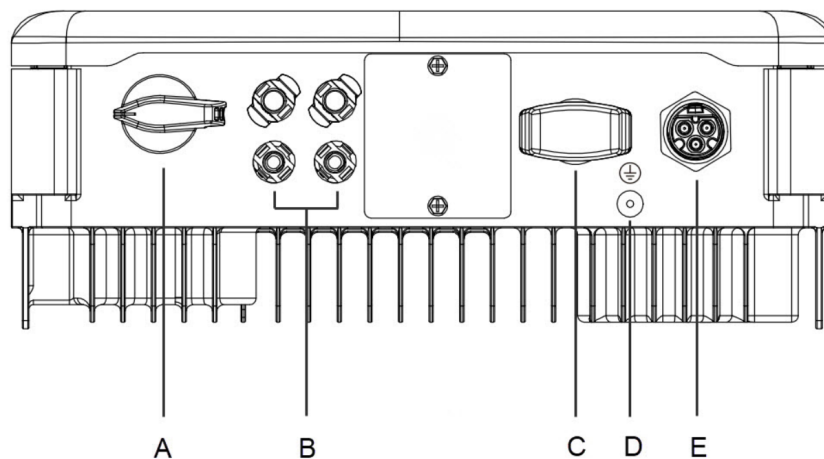

Fig. 13. Surveying the connection area

A	DC integrated isolator switch	D	Housing grounding
B	DC connector for PV generator	E	AC connection socket
C	Connection for Communication unit		

7.3 Making the electrical connection



NOTE

Select conductor cross-section, safety type and safety value in accordance with the following basic conditions:

Country-specific installation standards; power rating of the device; cable length; type of cable installation; local temperature

7.3.1 Requirement for supply lines and fuse

DC-side	
Max. outer diameter	5 – 8 mm
Max. cable cross-section (with wire sleeves)	2.5 - 6 mm ² (DC plug connector)
Recommended cable type	Solar cable
AC-side	
Max. conductor cross-section	4 - 6.0 mm ²
Max. outer diameter (with wire sleeves)	10 - 16 mm
Length of insulation to be stripped off	13 mm
Type of connection	Vaconn AC connector
Fuse protection for installation provided by customer	Max 25 A at 6 mm ²
Tightening torque	1.4 Nm
Communication	
Recommended RS485 bus cable	LiYCYv (twisted pair) black for laying cable outside and in the ground, 2 x 0.5 mm ² LiYCY (twisted pair) grey for dry and damp indoor spaces, 2 x 0.5 mm ²

7.4 Connecting the device to the power grid

7.4.1 Configuring the AC connection plug

🔄 You have completed assembly.

1. Slide the cable fitting over the cable.
 2. Select seal according to cable diameter used.
 3. Slide the housing and seal over the cable.
 4. Remove the insulation from the cable. [sl. 53 mm]
 5. Shorten the wires N, L by 2 mm more than the PE conductor.
 6. Strip the wires N, L, PE by 13 mm.
 7. Flexible wires must be fitted with wire sleeves in accordance with DIN 46228.
 8. Insert wires into the contacts in accordance with the markings on the contact carrier.
 9. Tighten screws on contact carrier. [$\times T_8$ / \triangle 2.0 Nm]
 10. Press contact carriers into the housing with an audible "click".
 11. Fix the housing and tighten the cable screw fitting. [$\times W_{29}$ / \triangle 3.5 Nm]
- » Make the electrical connections.

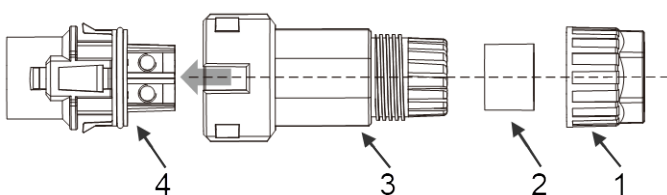

Fig. 14. AC connection plug

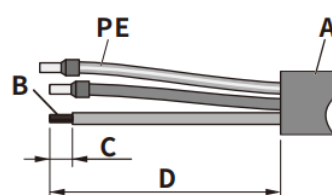

Fig. 15. Connect wires

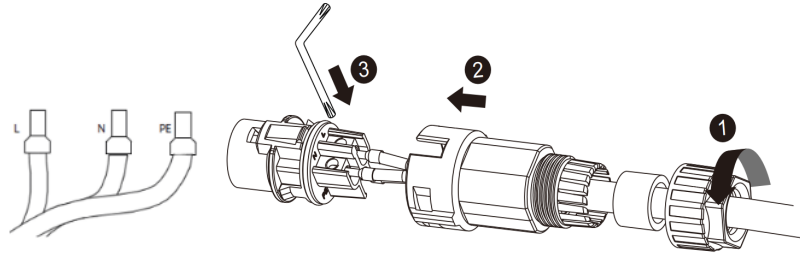
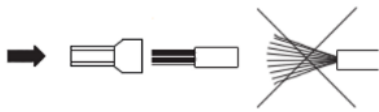

Fig. 16. Crimp wire sleeve to the contact

Fig. 17. Tighten the cable screw fitting

Key

1	Cable fitting	A	External diameter ($\phi 10$ to 16 mm)
2	Seal	B	Conductor cross-section (4 to 6 mm ²)
3	Housing	C	Stripping length of the insulated cables (approx. 13 mm)
4	Contact carrier	D	Stripping length of the outer sheath of AC cable (approx. 53 mm)

7.4.2 Make AC connection

⌚ AC connection plug configured correctly.

1. Insert the AC connection plug into the device connector on the device.

⇒ **NOTE: The AC connection is secure when an audible click is heard.**

2. Lay the cables correctly and in accordance with the following rules:

- Lay the cables around the device with a minimum clearance of 20 cm
- Never lay cables over semiconductors (cooling bodies).
- Excessive bending force may negatively impact the protection rating. Lay the cables with a bending radius of at least 4 times the cable diameter.

» The device is connected to the power grid.

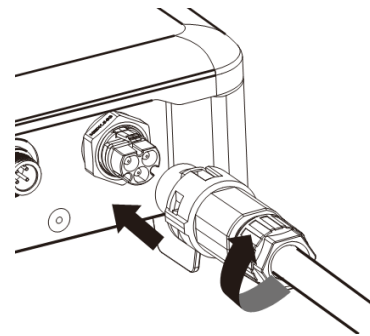

Fig. 18. Engage the AC connector with the device connector



NOTE

An AC-side disconnection unit must be provided during the final installation stage. This disconnector mechanism must be installed so that it can be accessed at any time without obstruction.



NOTE

If a residual current circuit breaker is necessary due to the installation specification, a type A residual current circuit breaker must be used.

For questions regarding the appropriate type, please contact the installer or our KACO new energy customer service.



NOTE

When the line resistance is high, i.e. long cables on the grid side, the voltage at the grid terminals of the device will increase in feed-in mode. If the voltage exceeds the country-specific grid overvoltage limit value, the device switches off.

Ensure that the cable cross-sections are sufficiently large or that the cable lengths are sufficiently short.

7.5 Connecting the PV generator to the device

7.5.1 Configuring the DC connector

DANGER

Risk of fatal injury due to electric shock!

Coming into contact with live connections can cause serious injury or death. When there is sunlight present on the PV generator, there is DC voltage on the open ends of the DC cables.



- › Make sure that PV modules have good insulation against ground.
- › On the coldest day based on statistical records, the max. open-circuit voltage of the PV modules must not exceed the max. input voltage of the inverter.
- › Check the polarity of DC cables.
- › Ensure that the device is completely free of DC voltage.
- › Do not disconnect DC connectors under load.

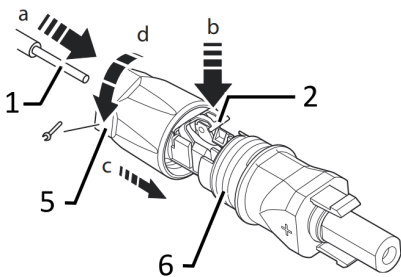

Fig. 19. Insert wires

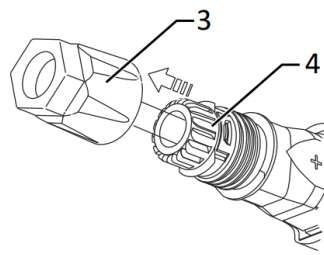

Fig. 20. Slide insert into sleeve

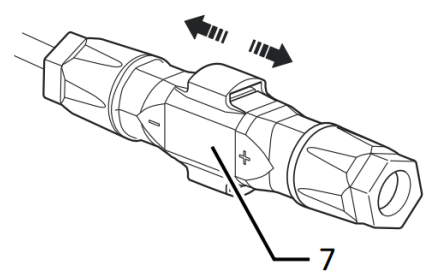



Fig. 21. Check fastening

Legend

1	Wire for DC connection	5	Cable fitting
2	Spring	6	Contact plug
3	Insert	7	Coupling
4	Sleeve		

 Connection area opened.

 **NOTE: Before proceeding with the isolation ensure that you do not cut any individual wires.**

1. Insert isolated wires with twisted ends carefully up to the connection.

NOTE: Wire ends must be visible in the spring.

2. Close the spring in such a way that the spring latches.

3. Slide insert into sleeve.

4. Secure and tighten the cable fitting [$\times W_{15}$ / m 1.8 Nm].

5. Join insert with contact plug.

6. Check latch by lightly pulling on the coupling.

› Make the electrical connections

NOTE



The permissible bending radius of at least 4x the cable diameter should be observed during installation. Excessive bending force may negatively impact the protection rating.

- › All mechanical loads must be absorbed in front of the plug connection.
- › Rigid adaptations are not permitted on DC plug connectors.

7.5.2 Checking the PV generator for a ground fault

DANGER



Risk of fatal injury due to electric shock!

Coming into contact with live connections can cause serious injury or death. When there is sunlight present on the PV generator, there is DC voltage on the open ends of the DC cables.

- › Only touch the PV generator cables on the insulation. Do not touch the exposed ends of the cables.
- › Avoid short circuits.
- › Do not connect any strings with a ground fault to the device.



NOTE

The threshold value from which the insulation monitor reports an error can be set in the “Parameters” menu.

Ensure that there is no ground fault

- 1 Measure the DC voltage between the protective earth (PE) and the positive cable of the PV generator.
- 2 Measure the DC voltage between the protective earth (PE) and the negative cable of the PV generator.
 - ⇒ If stable voltages can be measured, there is a ground fault in the DC generator or its wiring. The ratio between the measured voltages gives an indication as to the location of this error.
- 3 Rectify any errors before taking further measurements.
- 4 Measure the electrical resistance between the protective earth (PE) and the positive cable of the PV generator.
- 5 Measure the electrical resistance between the protective earth (PE) and the negative cable of the PV generator.
 - ⇒ In addition, ensure that the PV generator has a total insulation of more than 2.0 MOhm, since the device will not feed in if the insulation resistance is too low.
- 6 Rectify any errors before connecting the DC generator.

7.5.3 Recommended standard connection

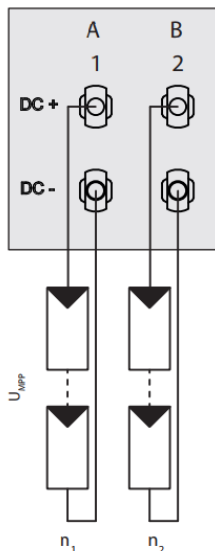

Possible connection

Two PV generators for each MPP tracker

The MPP voltages of the two DC strings can be different. They are supplied by separate, independently operating MPP trackers (MPP trackers A and B).

Number of modules per string:

P_{max} per string < 0.6 * max. recommended PV generator power

MPP tracker A+B together < max. recommended PV generator power

I_{max} : Depending on PV generator

The input current per MPP tracker must not be exceeded 12 A

Fig. 22. Recommended connection for blueplanet 5.0 NX1

7.5.4 Designing the PV generator

CAUTION



Damage to components due to faulty configuration!

In the expected temperature range of the PV generator the values for the no-load-voltage and the short circuit current must never exceed the values for U_{dcmax} and I_{scmax} in accordance with the technical data.

- › Observe limit values in accordance with the technical data.



NOTE

Type and configuration of the PV modules

Connected PV modules must be dimensioned for the DC system voltage in accordance with IEC 61730 Class A, but at least for the value of the AC grid voltage.



NOTE

Dimensioning the PV generator

The device is designed with a reserve of DC short-circuit current resistance. This allows for oversizing of the connected PV generator. The absolute limit for the PV generator is the value of the max. short-circuit current ($I_{sc\ max}$) and the max. no-load voltage ($U_{oc\ max}$).

7.5.5 PV generator

⚠ DANGER



Risk of fatal injury due to electric shock!

Coming into contact with live connections can cause serious injury or death. When there is sunlight present on the PV generator, there is DC voltage on the open ends of the DC cables.

- › Only touch the PV generator cables on the insulation. Do not touch the exposed ends of the cables.
- › Avoid short circuits.
- › Do not connect any strings with a ground fault to the device.

⚠ CAUTION



Damage to the PV generator in case of faulty configuration of the DC connector

Incorrect configuration of the DC connector (polarity +/-) leads to device damage in the DC connection if it is connected permanently.

- › Please check polarity (+/-) of the DC connector before connecting the PV generator.
- › Before using the solar modules, check the vendor's calculated voltage values against those actually measured. The DC voltage of the PV system must not exceed the maximum no-load voltage at any time.

Connecting the PV generator

⌚ The DC plug connector has to be configured and PV generator checked to ensure there is no ground fault.

1 Remove protective caps from the required DC connection plugs on the underside of the device.

2 Connect the DC plug connectors to the DC positive and DC negative connectors in pairs.

» The device is connected to the PV generator.

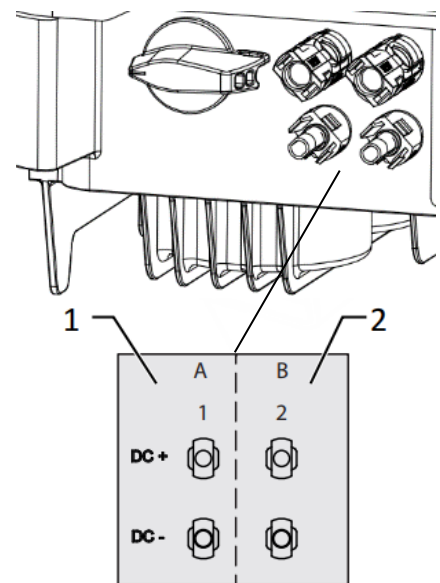

Fig. 23.Connection for DC+ and DC-

Closing the unused DC connectors

⌚ All existing strings are connected to the device.

NOTE: Meet the requirements of protection class IP65 by closing the unused plug connectors with the enclosed protective caps.

1 Press down the clamping bracket and push the forcing nut up to the thread. Insert the sealing plug into the DC plug connector and tighten the forcing nut.

2 Finally, insert DC plug connectors with sealing plugs into the corresponding DC input terminals on the device.

» Unused DC plug connectors are closed.

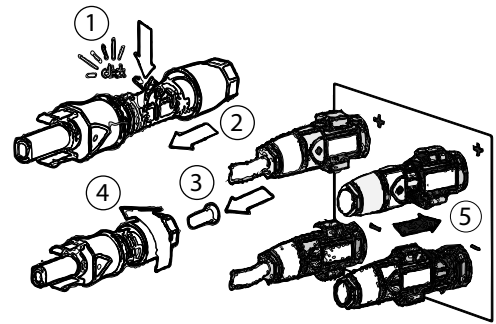

Fig. 24. Insert DC plug connectors and close unused connectors

7.6 Creating equipotential bonding



NOTE

Depending on the local installation specifications, it may be necessary to earth the device with a second ground connection. To this end, the threaded bolt on the underside of the device can be used.

⌚ The device has been installed on the mount.

1 Insert the grounding conductor into the suitable terminal lug and crimp the contact.

2 Align the terminal lug with the grounding conductor on the screw.

3 Tighten the screw tightly into the housing [\times P_2/ \approx 1.6 Nm].

» The housing is included in the equipotential bonding.

Legend

1	M4 terminal lug	3	M4 screw
2	Earthing ground conductor		

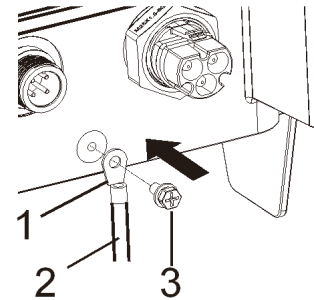

Fig. 25. Connect the grounding

7.7 Connecting the interfaces

7.7.1 Connection for Communication unit



NOTE

Damage to the inverter from electrostatic discharge

Components inside the inverter can be damaged beyond repair by electrostatic discharge.
› Earth yourself before touching the components.



NOTE

Damage to the Communication unit due to rotation of the stick housing

When the Communication unit is attached to the inverter, the nut on the stick must be turned. The Communication unit can be damaged if you rotate the housing of the stick.

› Do not rotate the actual Communication unit when attaching it to the device.

⌚ The device has been installed on the mount.

1 Remove the cap on the COM connector.

2 Insert the Communication unit into the existing connection and screw it tightly into the connection using the nut on the module.

NOTE: Do not rotate the actual Communication unit when attaching it to the device.

3 Ensure that the Communication unit is securely connected and the label on the module can be seen.

» The Communication unit is connected to the device.

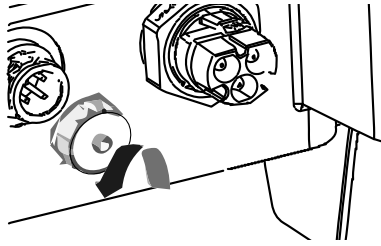

Fig. 26. Remove the cap

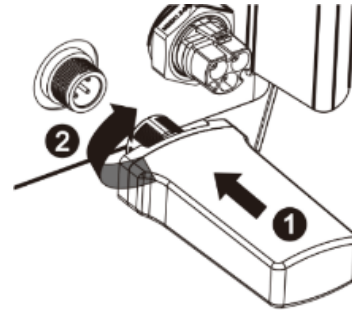

Fig. 27. Connect the Communication unit

7.8 Connecting the Smart-Meter for dynamic feed-in

If you want to implement the function dynamically, you need to install the Smart Meter. The Communication unit is compatible with the **Eastron Smart-Meter (SDM230 – Article no. 2015113)** and is available via our customer service.



NOTE

The Smart-Meter must support the MODBUS protocol and communicates with baud rate 9600, parity “None”, Stop-Bits “1”

Ensure that individual wires at the terminal contact of the Smart-Meter are attached with the correct torque and cannot work loose. Attach protective cover if fitted.



NOTE

Damage to the inverter from electrostatic discharge

Components inside the device can be damaged beyond repair by electrostatic discharge.

› Ground yourself before touching a component.



NOTE

A network cable of category 5E or higher is required for connection to the RJ45 socket. A network cable with good resistance to UV radiation is also required for use outdoors.

The RS485 connection can support communication with a maximum installation length (across all inverters) of 1000 m. The individual and control connected must be measured in accordance with EMC requirements EN 62920 if the length of the cable attached at the signal and control connection is more than 30 m according to the standard.

⌚ The device and the Smart-Meter have been firmly installed on a mounting bracket.

1. Fit suitable wire sleeves in accordance with DIN 46228-4 to the wires of the required cable and crimp [wire cross-section 0.5 - 0.6 mm²]

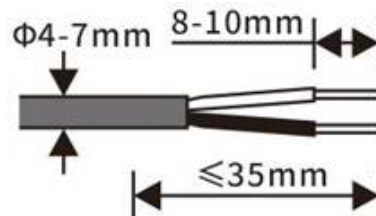

Fig. 28. Configuring the cable

2. Remove the protective cover from the housing base. (See Fig. 29)
3. Release the forcing nut (Pos. 1) of the cable fitting at the terminal (See Fig. 30).
4. Remove closing plug (Pos. 2) for required communication line, route the line through the forcing nut, the sealing sleeve and terminal, and guide the communication line with three turns through the magnetic ring (Pos. 3).
5. Connect wires of the cable to terminal (Pos 4) as assigned (A/B). [Screwdriver type: PH2, tightening torque: 1.6Nm]
6. Ensure that the cable is firmly attached.

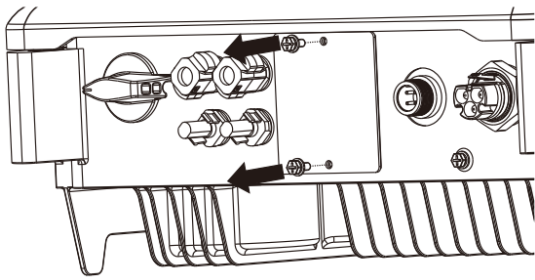

Fig. 29. Removing protective cover

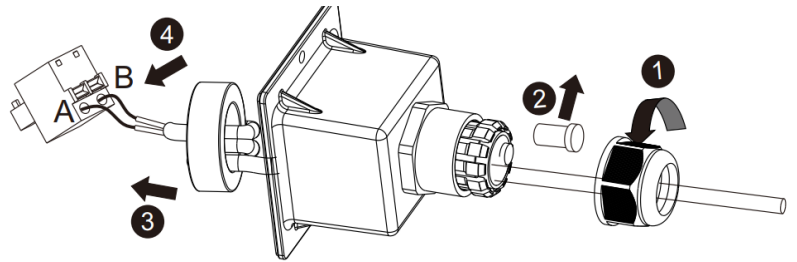

Fig. 30. Routing line through terminal

7. Insert configured terminal into the socket provided. Mount terminal on device using screws of protective cover [screwdriver type: PH2, tightening torque: 1.6 Nm] and tighten forcing nut [tightening torque 3.0-3.5 Nm].

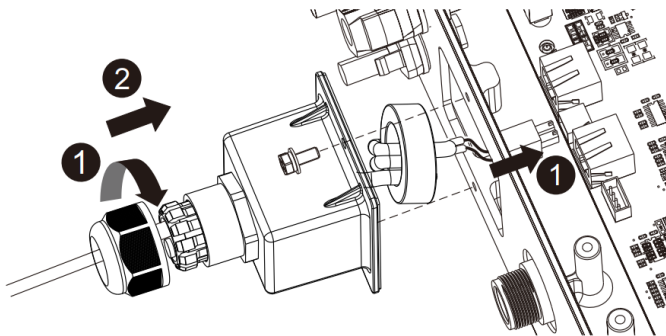
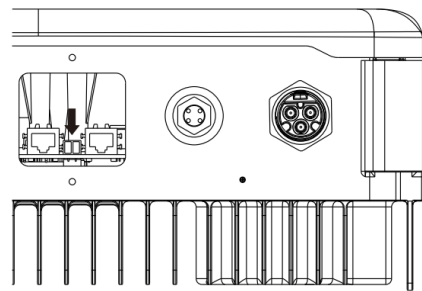

Fig. 31. Inserting terminal into the socket



8. Fit wire sleeve to the other end of the cable and connect to the contacts of the Smart-Meter. Screwdriver type: PH0, tightening torque: 0.7 Nm See Fig. 32

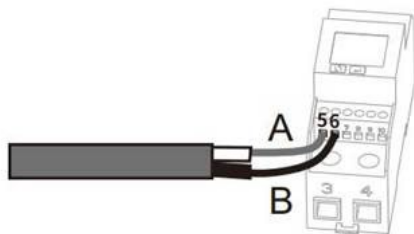

Fig. 32. Connection to SDM 230



NOTE

Accessories package: NX1 smart meter connection kit (Art. 3015112)

The kit (terminal with seal, clamp, magnetic ring) is available via our customer service.

<https://kaco-newenergy.com/service/customer-service/>

8 Commissioning

8.1 Requirements

DANGER



Lethal voltages are still present in the connections and cables of the device even after the device has been switched off and disconnected!

Coming into contact with the lines and/or terminals/busbars in the device can cause serious injury or death.

- › The device is only permitted to be commissioned by a qualified professional.
- › Unauthorised persons must be kept away from the device.

↻ The device has been mounted and electrically installed.

↻ The PV generator supplies a voltage above the configured start voltage.

1 Connect the grid voltage using the external circuit breakers.

2 Connect the PV generator using the DC isolator switch (0 > 1)

» The device begins operation.



NOTE

For initial start-up of the device, the enclosed WiFi stick must be plugged into the connection port. A mobile terminal device with a WIFI interface is required for monitoring and setting parameters. No serial number dependent password is required here.

The following functions are only available via the associated app:

1. Initial start-up.
2. Setting parameters
3. Special parameters (e.g. P(f), P(U), Q(U))
4. Reset to Factory defaults.

8.2 Preconditions relating to standards

Attachment of safety label in accordance with UTE C15-712-1

The code of practice UTE C15-712-1 requires that, upon connection to the French low-voltage distribution network, a safety sticker showing a warning to isolate both power sources when working on the device must be attached to each device

- Attach the safety sticker provided to the outside of the device housing where it is clearly visible.



9 Configuration and operation

9.1 Start condition

- ⌚ The Communication unit is connected to the device and firmly screwed in place.
- ⌚ The device is connected on the AC and DC sides **and** supplied with sufficient DC voltage.

Note: Note the status of the LED during initialization, during operation and in the event of fault messages. This can provide you with accurate information about the current operating status of the device.

- 1 Check on the Communication unit that the blue LED lights up during the initialization process. If not, check the fastening again. Otherwise, replace the Communication unit.
- 2 Check on the device that the white LED lights up in feed mode. If not, there is a fault in the device.

Note: In case of faults, refer to the error code in Chapter 10.5

» Continue to set up the device monitor.

9.2 Initial start-up

Initial start-up of the inverter is carried out via a hotspot WLAN connection between the Communication unit (WiFi stick) connected to the inverter and a mobile terminal unit with installed “KACO NX Setup” APP.

There are two ways to connect with the hotspot created by this unit:

- Establish a simplified connection with the Communication unit by opening the APP and reading in the QR code on the Communication unit with Setup Mode. After scanning the QR code, you will be shown a WLAN network with the name **B....** . When selecting this WLAN network, it is not necessary to enter a password. Your mobile device will connect to the device automatically.
- Connect by opening the WLAN settings on the mobile terminal device and selecting the WLAN connection with the designation **B....** and entering the password (registration code).
Note: The name SSID (serial number of the WiFi stick B..) and password (registration code) of the Communication unit can be found printed on the WiFi stick.
- You are successfully connected to the communication unit.

Step 2: Configuring the communication unit and inverter

We recommend the following steps for the initial start-up:

- **Configuration communication unit**
 - Set up time zone. See Chapter 9.7.1 on page 31
 - Configure network parameters See Chapter 9.7.3 below on Page on page 33 (Communication Unit Properties)
 - Setting the monitoring and control functions See Chapter 9.7.4 below on page 34 (Monitoring & Control)
- **Configuration Inverter**
 - Select country and grid standard See Chapter 9.9.3 below on page 38.
 - Set local grid requirement (observe local grid requirements! E.g. cos-phi, P(f), Q(U)...) See Chapter 9.11 below on page 39
 - View the instantaneous values of the inverter in order to detect any faults. See chapter 9.9.1 below on page 37.



NOTE

For further settings such as power control, zero-feed in or communication with a data logger, please refer to chapter 9.11 below

9.3 Authorisation



NOTE

In order to use the full range of functions of the “KACO NX SETUP” app, you should accept **all** requested authorisations. The app does not use these authorisations to record the user’s telephone data. The **current** description reflects the firmware version **1.0.15**. With newer firmware versions the **following subchapters** will be updated in time to inform you about current functions.



NOTE

If your device has a software version of **V08** or **higher**, you will have many additional functions. However, you can **update** your **V06/V07** version with \geq V08 available on **our website** as described in the chapter 9.14.



NOTE

Our KACO website offers a wide range of further product information to assist you during start-up. You can find this information in the download area under: <https://kaco-newenergy.com/de/downloads/>.

Follow the **QR code link** on the cover sheet to view the installation and start-up video.



NOTE

No password is required for **initial start-up**. A password must be entered again if it becomes necessary to change the parameters of the device after initial start-up.

The specific password for the inverter can be requested from KACO Service. <https://kaco-newenergy.com/de/service/kundendienst/>



NOTE

Frequency band:

Before configuring the network, please prepare a WLAN router that supports the 2.4G frequency band. The Communication unit can only be operated in the 2.4G frequency band.

Installation location

For a stable connection, the Communication unit or inverter should be no more than 10 m away from the router.

Availability of SSID and password of the router

The Communication unit supports only 32 characters for the SSID or password.



NOTE

We recommend integrating the Communication unit into your/your customer’s WLAN network, if the signal quality of the network is insufficient or non-existent, then you will need to continue with hot-spot connection.

To use monitoring and control functions (Monitoring Portal “blueplanet web”), there must be a connection to the internet via the customer’s WLAN network.

9.4 Operating system and system configuration

The corresponding, free APP **KACO NX Setup** from the relevant APP store can be installed on a mobile terminal unit (smartphone or tablet PC) with an **Android operating system, version 9.0 or newer** or **IOS operating system version 11.0 or newer**. You will find QR code links on the cover sheet.

Below you will find illustrations of the connection options for initial start-up of the device and its optional integration into a local network.

If you integrate the device into a local network, it is possible to connect the device to a web portal or a client (data logger, system controller).

Option 1: Set-up via hotspot (with APP connection to the inverter with Communication unit)

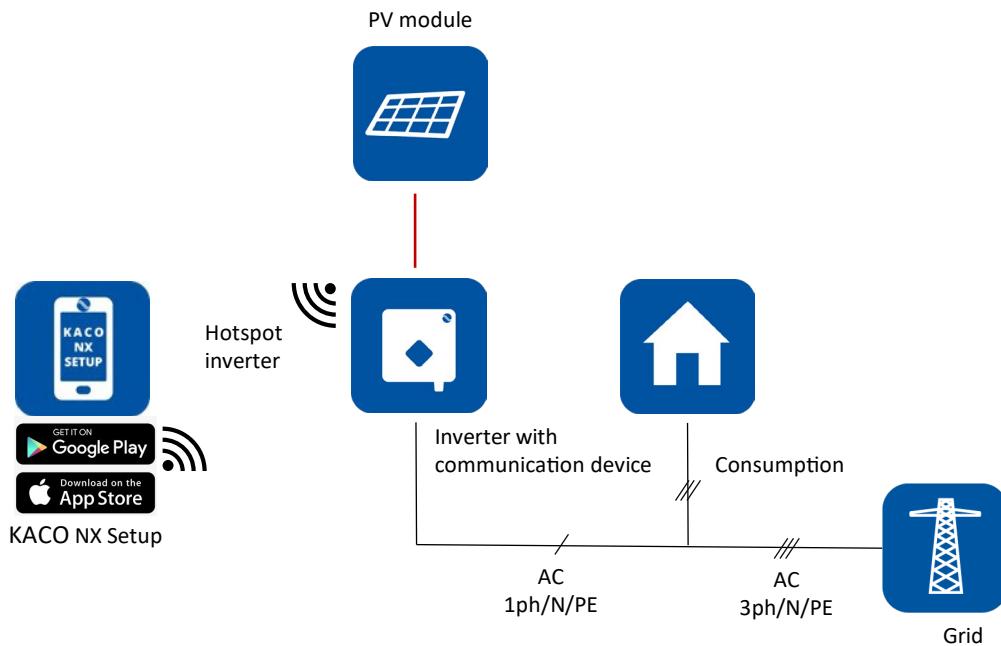

Fig. 33. Set up Communication unit via mobile end device – hotspot

Option 2: Set-up via local network

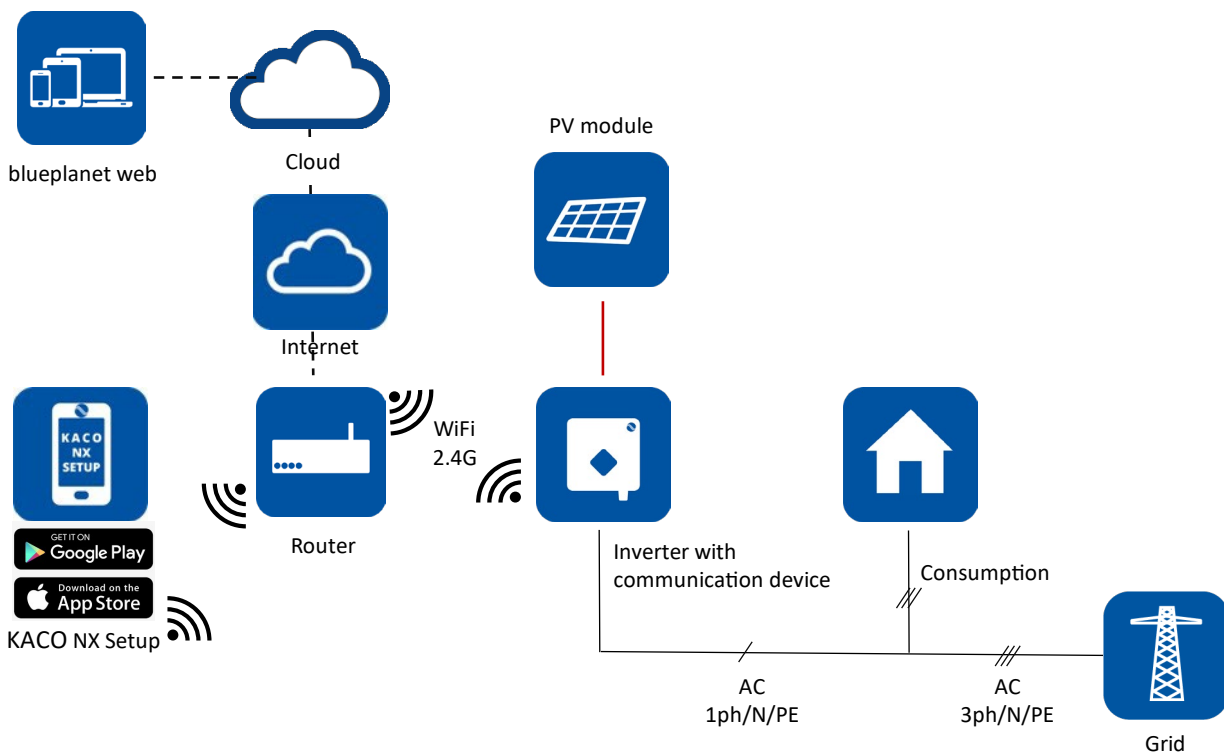

Fig. 34. Set up Communication unit via local network – WiFi2.4G

9.5 Signal elements

There are status LEDs on the Communication unit and on the inverter housing that indicate the operating status. The LEDs can display the following states:

	LED illuminated		LED flashing		LED flashes rapidly
---	-----------------	---	--------------	---	---------------------

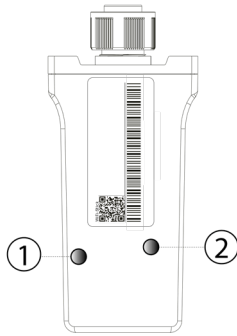

Fig. 35. LEDs on Communication unit

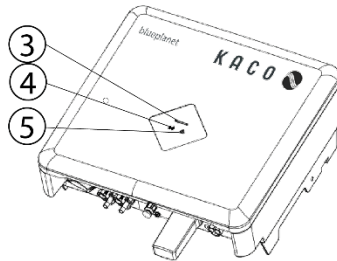













Fig. 36. LEDs on device

Item	Operating status on Communication unit	LED	Description
1	Network communication		Note: For AP network configuration, you must be connected to the device's local WLAN network to re-enter the router information. The password for the local WLAN network is the registration key found on the name plate (See Abb. 50 on Communication unit). The blue "Network" LED flashes when the Communication unit is connected to the WLAN network.
			The blue "Network" LED is illuminated when the inverter is connected to the web portal. If the LED does not light up, check if the network SSID and password are correct and if the WLAN signal is strong enough.
2	Device communication		The green "Operating" LED is illuminated when the Communication unit establishes communication with the device. If it does not light up, there is a hardware defect. Contact our service team.
			The green "Operating" LED flashes if the connection fails due to invalid router information. Use the "KACO NX Setup" APP to perform the network configuration.
			The green "Operating" LED flashes rapidly when the Communication unit is in network configuration mode. This disables the device's data capture function.
Item	Operating status on the device	LED	Description
3	Standby self-test		The white "Operating" LED flashes when AC and DC voltage is present. The device performs a self-test. After flashing, the device is ready for feed-in.
3	Feed-in operation		The white "Operating" LED is illuminated when the device is feeding into the grid. The LED goes off when there is a malfunction.
3	Feed-in mode with power reduction		Note: Dynamic power is also indicated by means of the LED. The white "Operating" LED flashes quickly if there is a power reduction of 45%-90%. If the power falls below 45%, the LED flashes slowly.
4	COM		The white "Communication" LED is illuminated during communication with other devices (data logger, Smart-Meter, Communication unit) and during a firmware update via RS485. The LED is not illuminated if the communication is interrupted or non-existent.
5	Fault		The red "Fault" LED lights up due to an error and the feed into the grid is interrupted. The corresponding error code is displayed in the KACO NX Setup APP in the Live values menu 9.9.1 on Page 37. If there is no fault, the LED goes out.

1-5	Offline		No LED is lit. There is no AC/DC supply to the device.
-----	---------	---	---

9.6 Connecting to the device

9.6.1 Connecting to the device for the first time

🔄 **WLAN of your mobile device is enabled,** and any existing customer WLAN network router is switched on.

Note: The initial connection is generally made via a hotspot.

🔄 The “KACO NX Setup” APP from the Android/iOS Store has been installed and opened on your mobile end device.

🔄 The Communication unit is connected to the COM port of the device. (See Chapter 7.7 on page 20)

Note: Each device in the device series must be configured with the **enclosed** Communication unit. Thereafter there is a fixed assignment to the device.

🔄 The access details for your / your customer’s WLAN network are to be made available to the solar installer.

1. Select <Start-up>.

2. Grant authorisation for use of images, videos and camera.

3. Scan the QR code on the Communication unit. Max. distance from the scan frame shown in the scan window. (See Fig. 40)

» The connection to the hotspot WLAN is established (**B...**).



Fig. 37. Select <Start-up>



Fig. 38. Scan QR code on Communication unit

Note: The connection is established exclusively via the hotspot until **step 6**. This is how long your mobile end device must be kept near the Communication unit.

4. Confirm the WLAN network of the Communication unit by tapping the B... number displayed.

Note: After a short time you will have 2 options in <Network Configuration>.

Option 1- Connect the Communication unit to the local WLAN network.

Option 2 –Use the existing hotspot: **Now follow the instructions in Chapter 9.7.2 on page 30**

5. Select the customer's WLAN network. The customer needs to enter the password and press the <Confirm> button.

Note: If the connection fails, the Communication unit is not in range of the customer's router. You can improve the signal quality between the Communication unit and the router by interposing a **repeater**. However, this must also be connected to the same network.

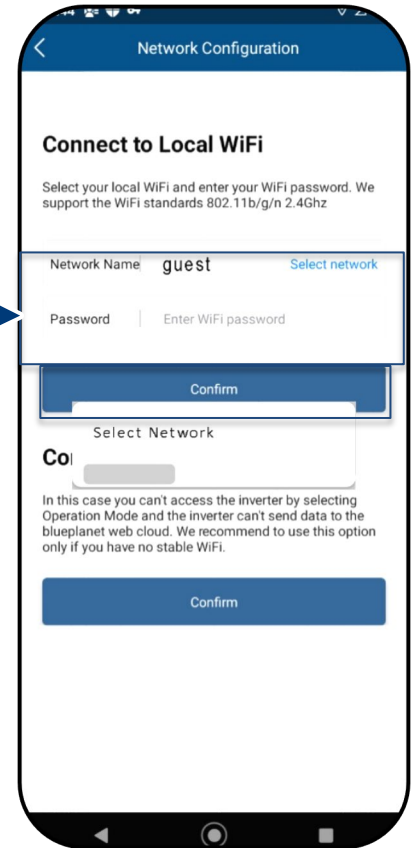
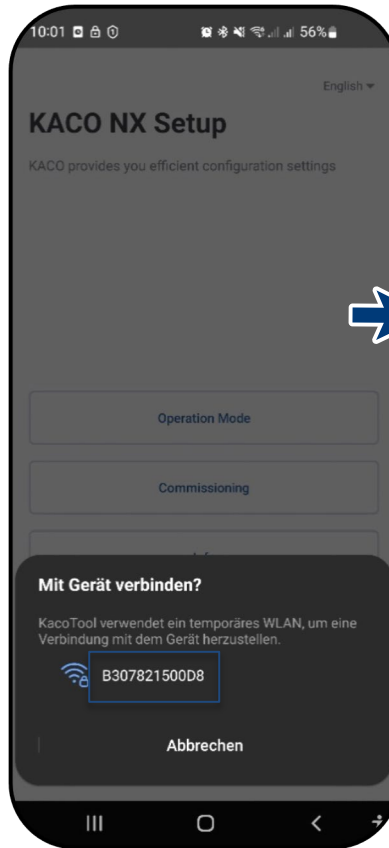

Fig. 39. Access to the Communication unit with a mobile end device

Fig. 40. Enter the access data for the customer's WLAN network

Note: If the connection is successful, your communication unit will be connected to the customer's WLAN network. Your mobile end device now also needs to be connected to the customer's WLAN network.

6. In <Settings> on the mobile end device, you now need to establish a connection with the customer's WLAN network.

Note: The password is pre-filled if a connection already exists.

7. Note the checklist and status. Process takes up to 5 minutes.

» Your communication unit and your mobile end device are now on the same customer WLAN network. A successful connection is displayed in a new window.

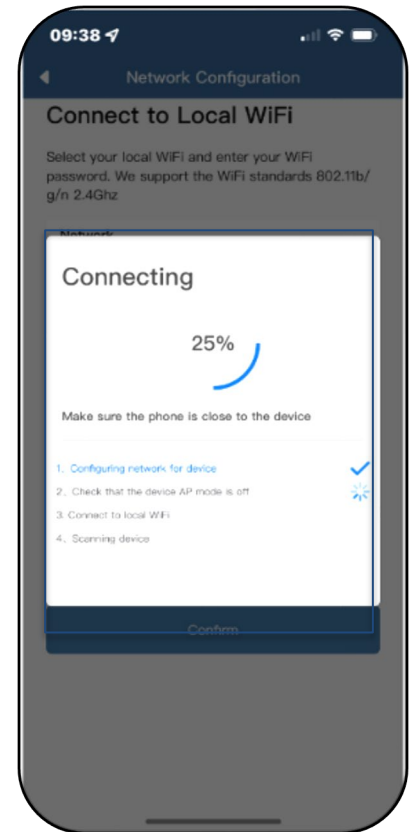
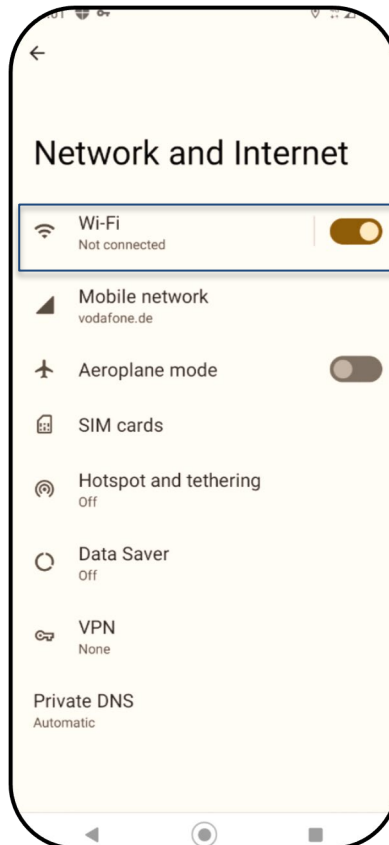
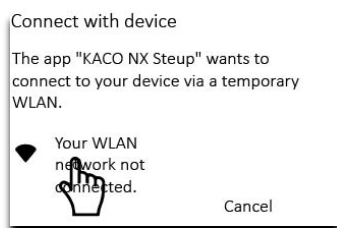

Fig. 41. Connect the inverter to the customer's WLAN

Fig. 42. Connect the mobile end device to the customer's WLAN

Fig. 43. The connection to the customer's WLAN network is established

Note: <Network configuration> displays information on the device serial number, software version and system time. If the system time is different, you can set it under <Timezone>.

8. <Confirm> that the Communication unit has been successfully connected to the customer's WLAN network.

Note: After a successful connection, the green LED on the Communication unit lights up continuously and the blue LED flashes. Please also refer to the description of the signal elements in Chapter 9.4 on page 27

Note: The software version is the firmware version of the Communication unit. You can update these as described in Chapter 9.14 on page 49 to bring the device up to the current functional status.

» The Communication unit is registered on the customer's WLAN network.

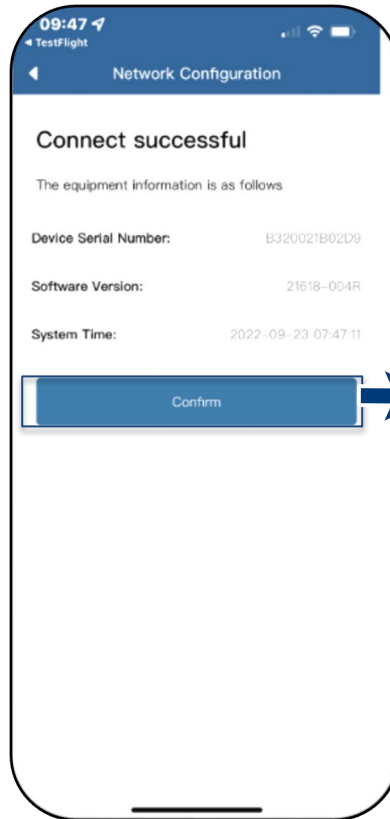

Fig. 44. Status when connection is successful (IOS only)



Fig. 45. Connection established – blue LED flashes.

9.6.2 Connecting the device via a hotspot (alternative)

Note: We recommend connecting the Communication unit to the customer's WLAN network.

However, if the signal quality of the network is insufficient or non-existent, you can connect the unit using a hotspot connection.

🔄 The “KACO NX Setup” APP from the Android/iOS Store has been installed and opened on your mobile end device.

🔄 A password is not required. However, you must be standing right next to the device to establish a connection.

1. Carry out action steps 1- 4 from Chapter 9.5.1.

2. Establish the hotspot connection by pressing <Confirm>.

Note: If no Communication unit is found, your mobile end device may not be close enough to the inverter.

» The Communication unit is connected to your mobile end device.

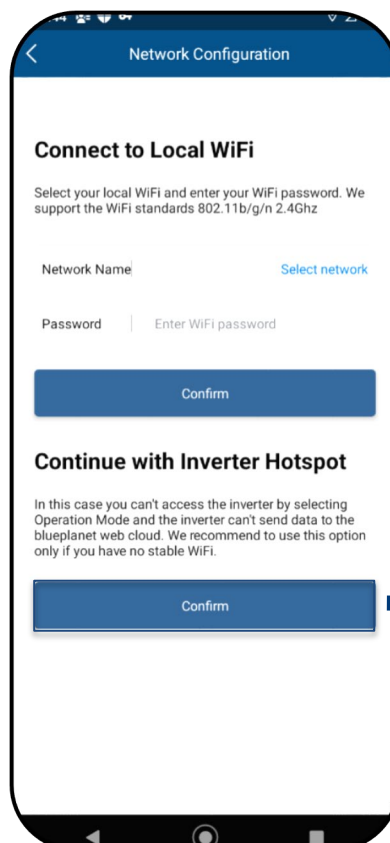

Fig. 46. Confirm inverter hotspot connection

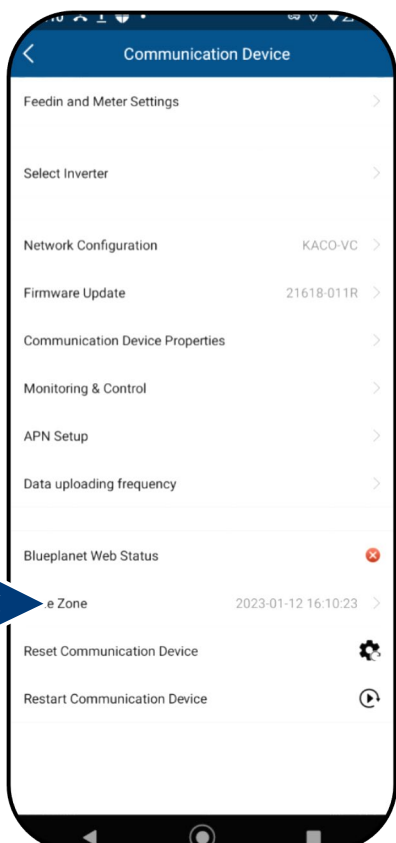

Fig. 47. Connection to the Communication unit established.

9.7 Menu of the Communication unit

Note: In both cases you now have access to the Communication unit. This is where you can make settings that do not directly affect the function of the inverter.

For initial start-up, we recommend calling up the following parameter:

- Set timezone. See chapter 9.8.1
- Set the same country and grid type for every connected inverter. (Observe local network requirements!) See chapter 9.8.5
- View live values of the customer's PV installation in order to detect faults, if necessary. Adjust other parameters, if necessary. See Chapter 9.6.4.
- Set up monitoring & control. See Chapter 9.8.2 on page 32.

Note: After completing or exiting initial start-up, the serial-number-based password is required to set further parameters. See Chapter 9.12.6 on page 37.

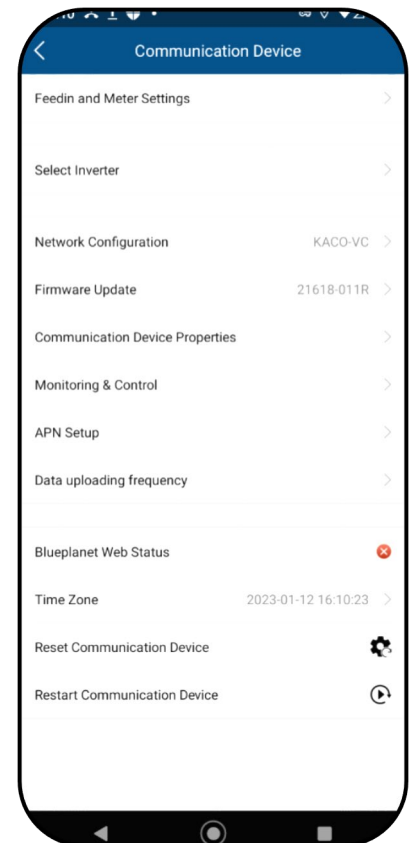

Fig. 48. Menu of the Communication unit

9.7.1 Setting the time zone

Note: The time communicated by the network is GMT. You should now adjust the time zone depending on the installation location.

This time is also used for the display on the "blueplanet web" portal.

1. Select time zone. For Germany, this would be Amsterdam, Berlin...

2. Save the selection with <Confirm>.

Note: If the internet is not available on the network, you will have to make the changeover to summer/wintertime manually.

» Time zone set.

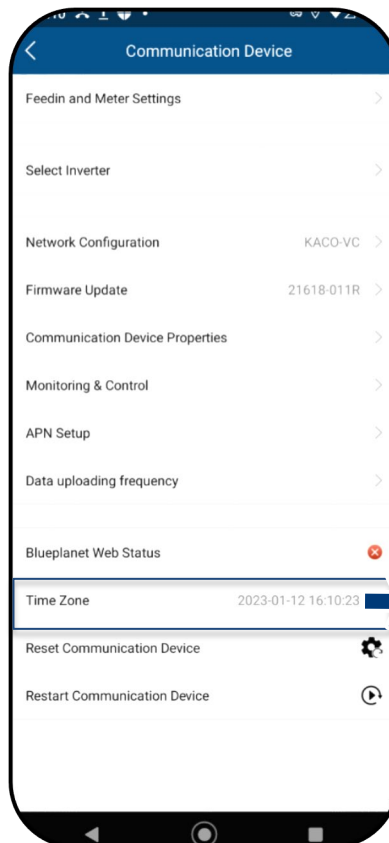

Fig. 49. Menu of the Communication unit



Fig. 50. Set time zone

9.7.2 Dynamic feed-in

↻ <Communication unit> menu opened.

↻ The connection shown in the block diagram Fig. 53 has been established.

Note: For more information, see Chapter 9.16 on page 52.

1. Select menu item <Feed-in control and Meter Settings>.
2. Select smart meter model >> SDM230
3. Switch on <Enable meter data processing> when the meter is connected.
4. Switch on <Enable feed-in control> when the meter is connected.
5. At <Maximum feed-in power>, set the maximum power which the device may feed into the grid.

Note: This setting is only possible under 2 conditions:

1. Meter model connected to the device.
2. <Active power regulation> is enabled in the <Settings for> menu under <Enable/disable functions>.

6. Start the function with <Confirm>.

5. Please remedy if these conditions are not met. See Chapter 9.13 on page 39

» Dynamic feed-in is selected.

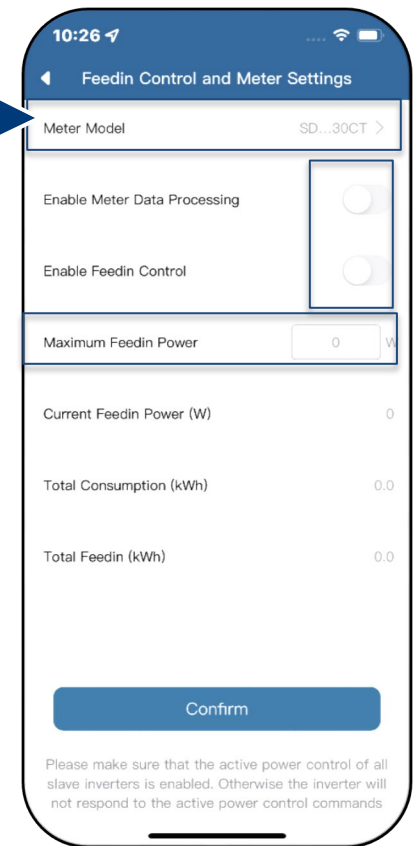
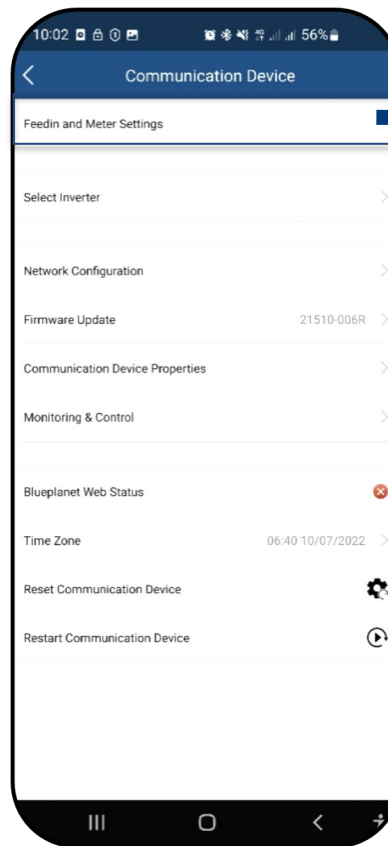

Fig. 51. Select feed-in and meter settings

Fig. 52. Select smart meter model and set max. feed-in power

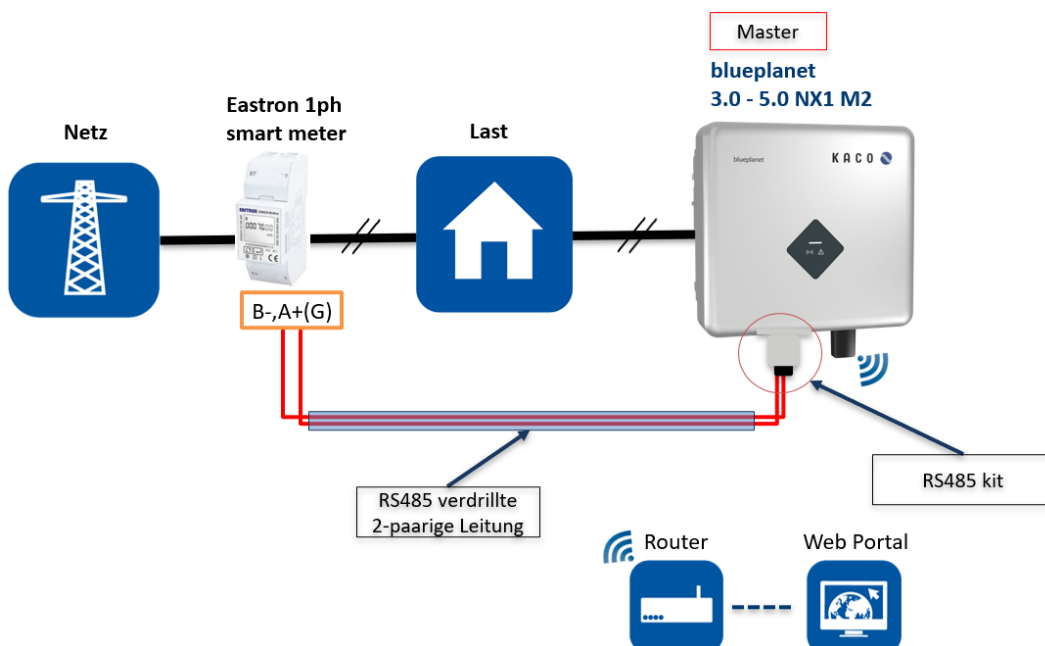

Fig. 53. Block diagram for dynamic feed-in

9.7.3 Configure network parameter

Note: Here you can assign a static IP address to the inverter so that your router always uses the same address.

↻ Connection to the device established

1. Select <Communication unit properties>.
 2. Activate <DHCP> for automatic IP address assignment or for greater security:
 3. Deactivate <DHCP> and enter the IP address for your inverter.
 4. Optional: Activate <DNS> and enter the primary DNS address.
 5. Save settings with <Confirm> button.
- » IP settings made successfully.

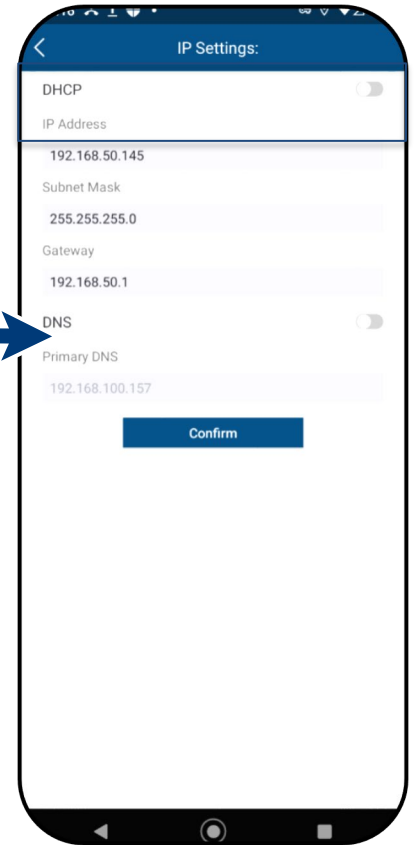

Fig. 54. View device parameters

Fig. 55. View all parameters

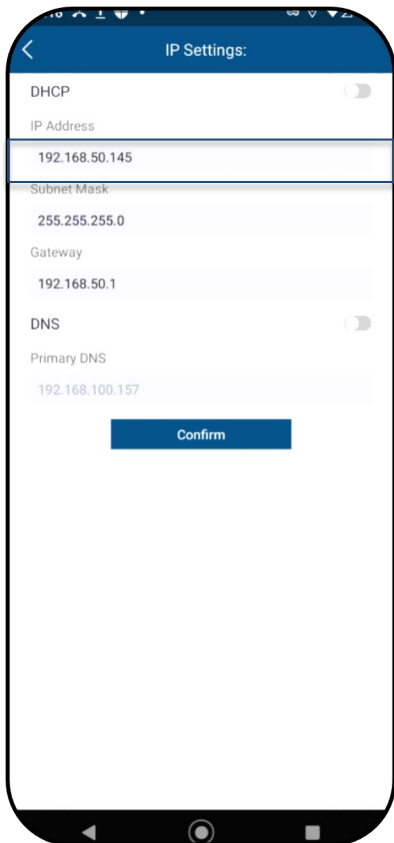

Fig. 56. Set IP address

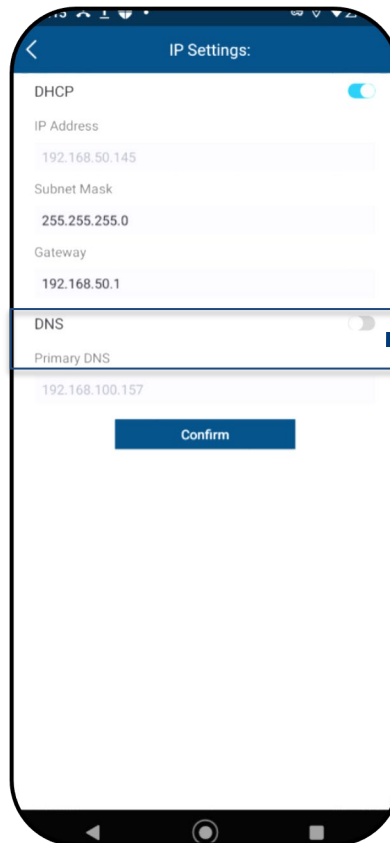

Fig. 57. Activate DNS

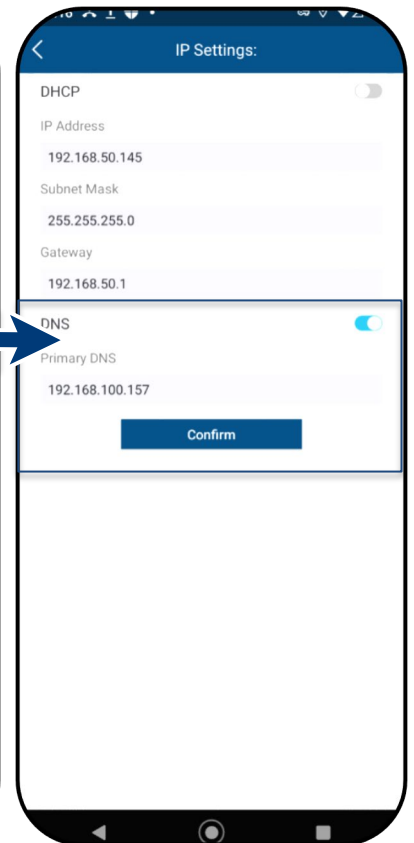

Fig. 58. Set DNS address

9.7.4 Monitoring and control

↻ The <Communication unit> is registered on the customer's WLAN network and the router is connected to the internet.

Note: The signal is transmitted via an installed RS485 line.

1. Select <Monitoring> mode:
 - <KACO web portal>: data from connected devices is uploaded to the KACO cloud server for evaluation.
 - <APP (local)>: local operation mode without further communication. (Standard)

2. Confirm the selection with <Confirm>.

» Operation mode set.

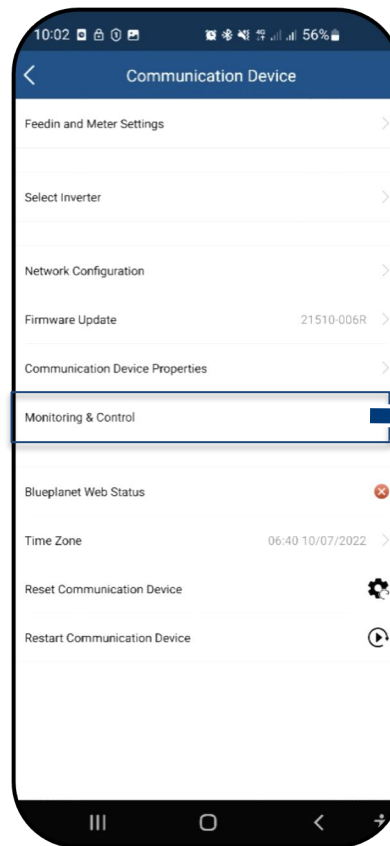

Fig. 59. Select monitoring & control

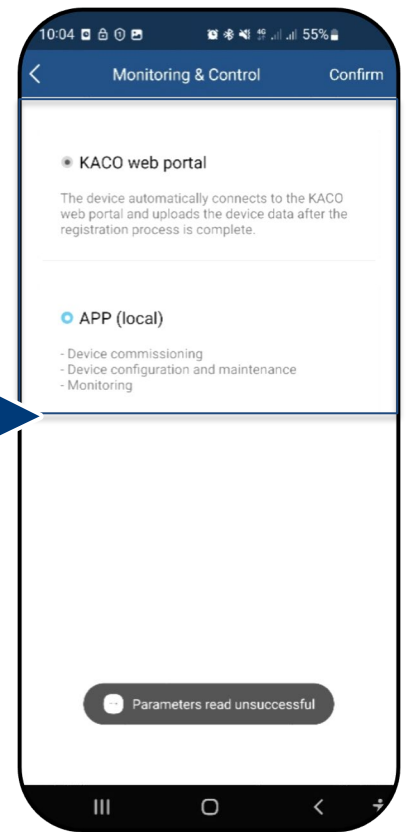

Fig. 60. Select mode

9.8 Additional functions

9.8.1 Changing the customer WLAN network

↻ <Communication unit> is open.

Note: This allows you to change the WLAN configuration when you replace the device, router or your mobile device.

1. Open <Network properties>.
2. Select the network in the <Network name> field using the drop-down menu.
3. Enter the password for the network and save the change with <Confirm>.

Note: If the router is defective or no longer reachable and the Communication unit cannot establish a connection and the blue LED lamp on the Communication unit does not light up, you can find the SSID of the Communication unit hotspot with the serial number of the Communication unit in your WLAN list. You can establish a connection with the hotspot of the Communication unit by entering the registration code on the label as a password.

Note: Data is transferred after approx. 30-60 minutes.

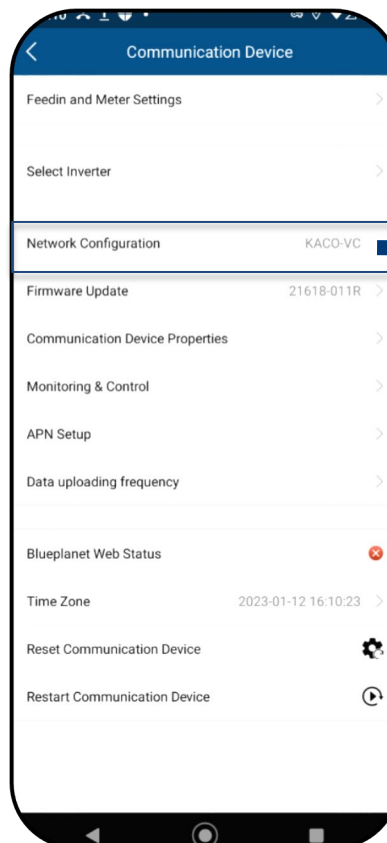

Fig. 61. Network properties

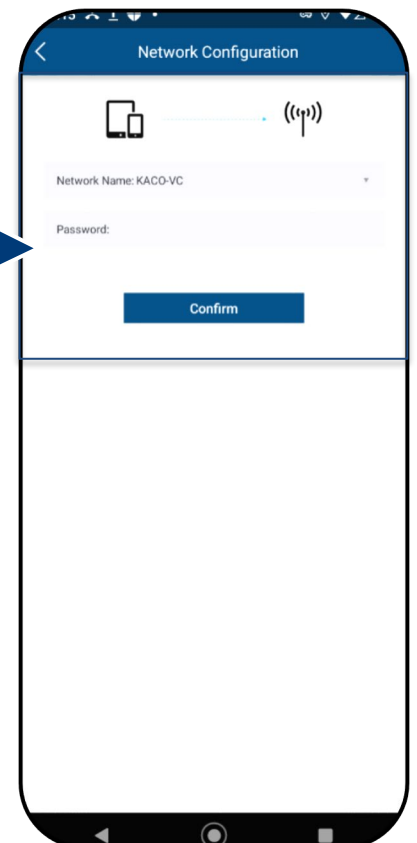

Fig. 62. Change network

9.8.2 Showing details of the WLAN connection

⌂ <Communication unit properties> has been opened from <Communication unit>.

1. First, check the quality of the WLAN connection in <Signal strength>. If this is marked as “Strong”, you have an optimal connection.

Note: Problem-free communication is only ensured if the signal quality is good. If necessary, improve the signal quality by decreasing the distance from the device and by removing objects which cause interference.

2. View the software version number of the Communication unit and the hardware version.

3. Adjust the IP setting if DHCP detection does not work. See 9.7.3 on page 33

» Details of the WLAN connection have been viewed.

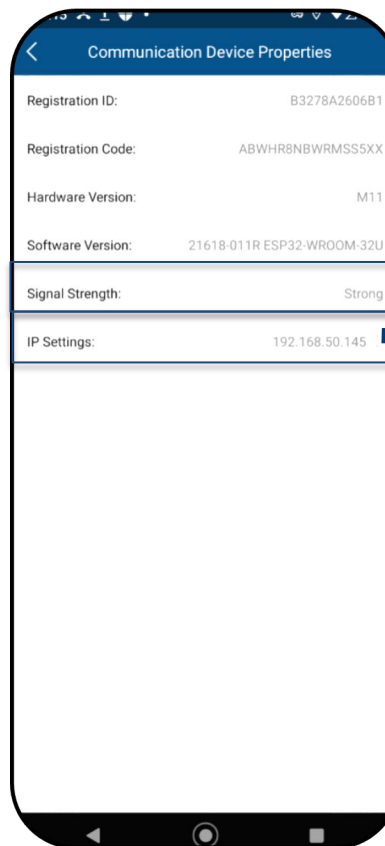

Fig. 63. View details of the WLAN connection

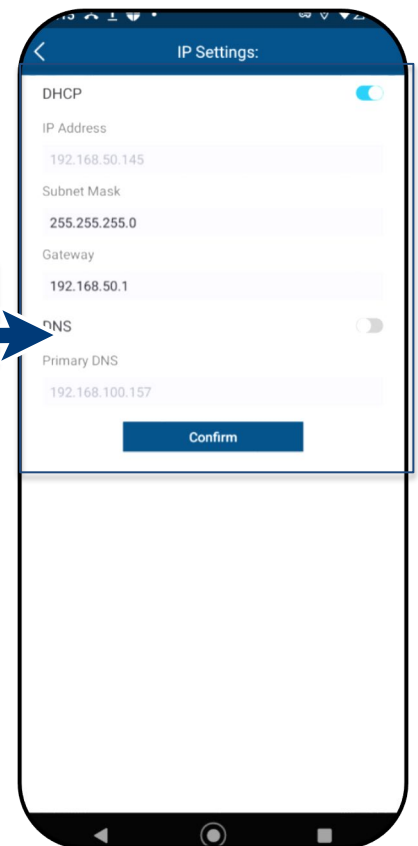

Fig. 64. Set static IP address

9.8.3 Resetting a faulty connection

⌂ <Communication unit> is open.

Note: The Communication unit is restarted via the <Restart Communication unit> icon. Set values on the device are **not** reset.

1. Press the <Confirm> button in the warning message to trigger a restart.

Important: Pressing <Reset Communication unit> resets **all** created configurations to the factory defaults.

2. Reset the Communication unit with <Reset Communication unit>.

» Check the connection after restart.

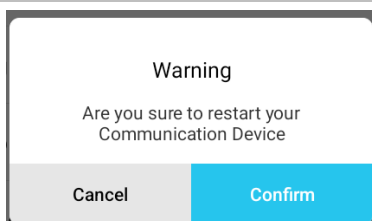

Fig. 65. Note for <Restart Communication unit> All configurations remain unchanged.

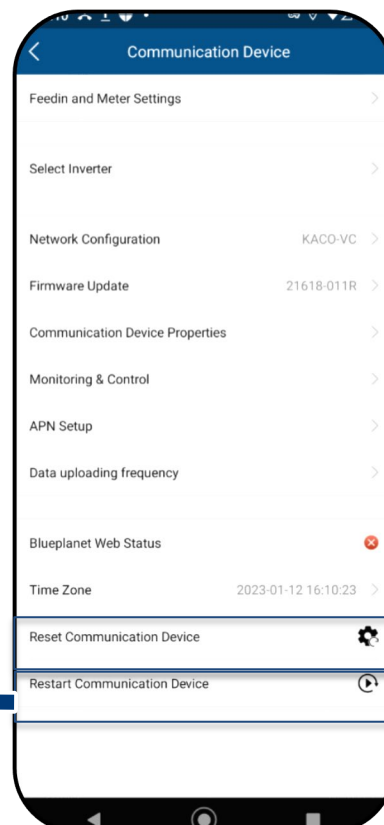

Fig. 66. Reset / restart the Communication unit

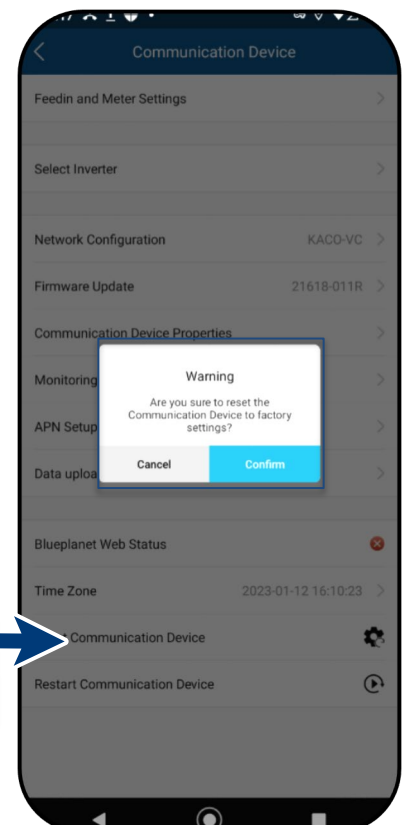

Fig. 67. Observe the note on resetting the Communication unit!



NOTE

The following settings are **reset** when the communication unit is reset:

- **Network configurations**
- **Feedin and Smart-Meter Settings**
- **Function Monitoring & Control**
- **Time Zone**
- **Internal inverter list from the communication unit is deleted from the memory.**

Note: Inverter settings are not reset by the communication unit during a restart.

9.8.4 View available inverters

- ↻ All inverters are connected via a communication unit.
- 1. Select the required <Inverter> under <Communication unit>.
Note: Up to 5 inverters can be connected to one Communication unit.
- 2. Adjust the parameters in <Parameter settings>.
>> see Chapter 9.11 on page 39 or:
- 3. View feed-in values of the selected device in <Live values> >> see Chapter 9.9.1 on page 37
- » Device configured with country setting.

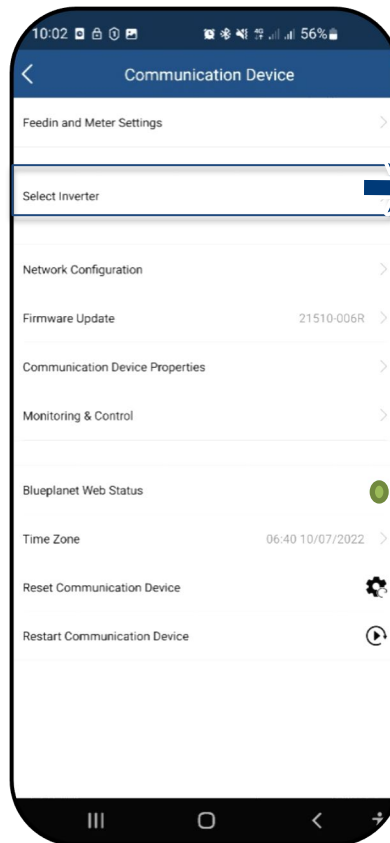

Fig. 68. Select inverter

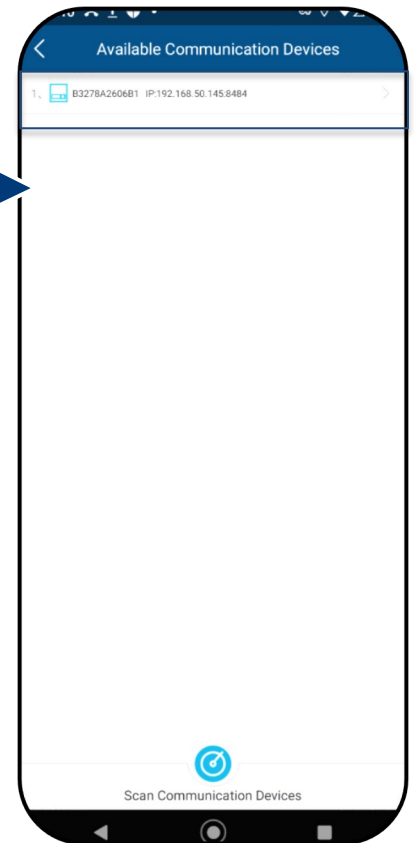

Fig. 69. Select the required inverter

9.9 Menu of Inverter

9.9.1 Viewing the Instantaneous values

🔄 The required device is selected in <Available inverters> and the <Inverter values & settings> menu is opened.

1. Select <Instantaneous values> and view information about the installation.

Note: All measured values for your PV system and the grid power are displayed. In addition, after solar feed-in, the daily values and yields are displayed.

Note: The measured values are only displayed for the selected device. A simultaneous evaluation of all inverters can only be carried out via our “blueplanet web” monitoring portal.

2. View current Power and Power Factor.

3. View pending errors via <Error Code>. N/A = no error

Note: In the event of a pending error, note the **Error code list** in chapter 10.5 on page 57.



Fig. 70. Viewing the live values

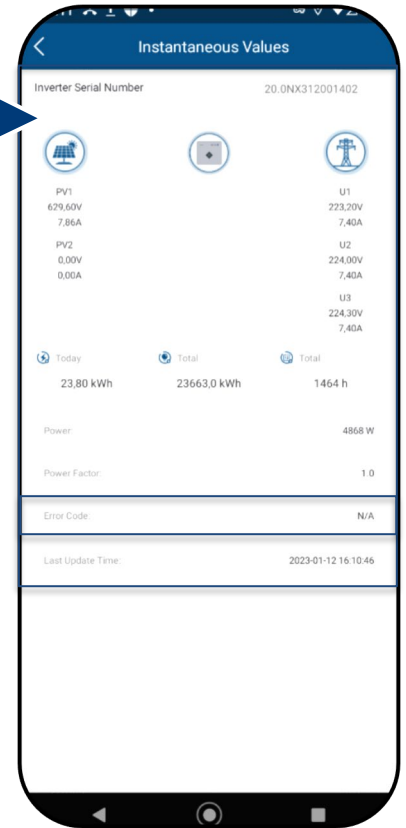

Fig. 71. Overview of power values

9.9.2 Authorisation to change parameters

🔄 <Live values and settings> menu has been opened from <Available Communication units> and <Find inverter>.

1. Open <Parameter settings> to set the parameters for initial start-up.

Important: No password is required for **initial parameter setting**. A password must be entered if it becomes necessary to change the parameters of the device after initial start-up (security function). The specific password for the inverter must be requested from KACO Service.

2. Enter the password in the <Password> field and confirm with <Confirm>.

Warning

Please complete the configuration completely before exiting the configuration mode.

Confirm

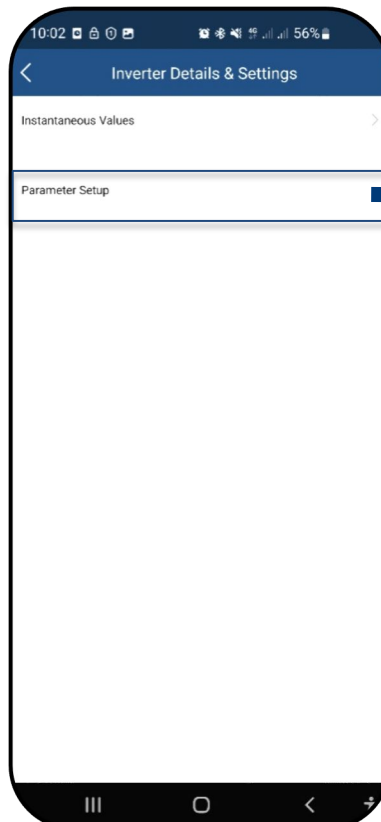

Fig. 73. Select parameter settings

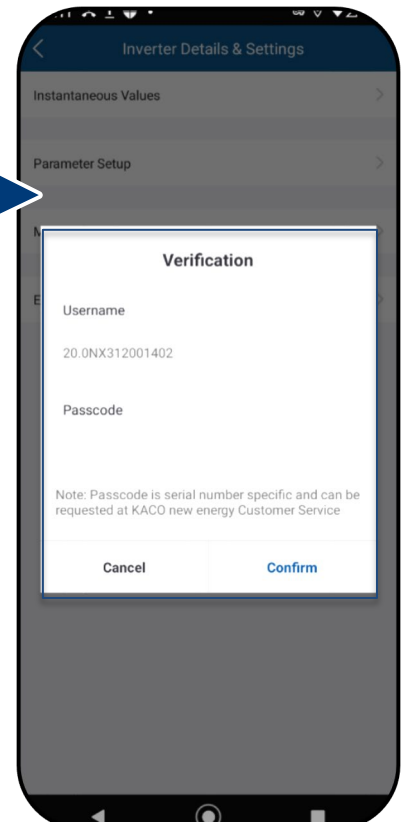

Fig. 74. Authorisation required

Fig. 72. Warning issued only on the **first** accidental abort attempt.

9.9.3 Selecting country and grid type

↻ The required device is selected in <Available inverters> and the <Settings for> menu is opened in the <Parameter settings> in the <Inverter values & settings> menu.

1. Select <Country / Grid>.

Caution: The following settings can only be made once without a password during initial start-up!

2. Select the operator country and **grid type** in the field according to the **grid operator requirements** and confirm with <O.K.>.

Note: By default, all required parameters are activated via the relevant grid code.

Note: When the grid standard has been changed, the device carries out a self-test. As a result, around 2 minutes may elapse before the device feeds in again.

Note: Further grid standards settings can be made if requested by the grid operator or customer (e.g., setting for reactive power, Q(U) curve, see Chapter 9.13.1).

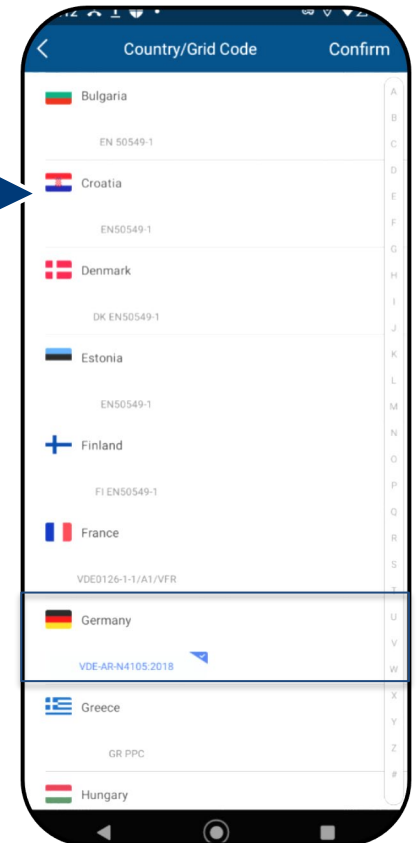
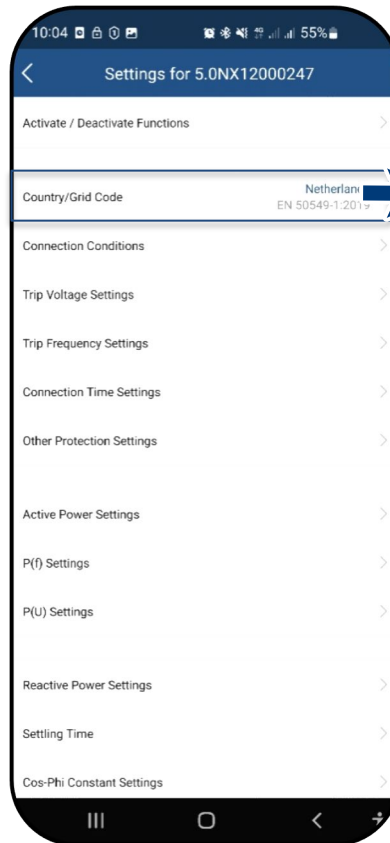

Fig. 75. Check or change country and grid-type

Fig. 76. Select country & grid code

9.10 Operation mode

9.10.1 Operation mode for normal operation

↻ You have made all the necessary basic settings.

1. Switch to <Operation mode> to view the menu of an <Available inverter>.

Note: As soon as the device appears, it can be selected immediately without having to wait for the search to finish (even if the screen is greyed out).

2 Now view all entries under <Settings for>. The menu of the <Communication unit> can be reached with ↵.

» The Communication unit is connected to your mobile end device.

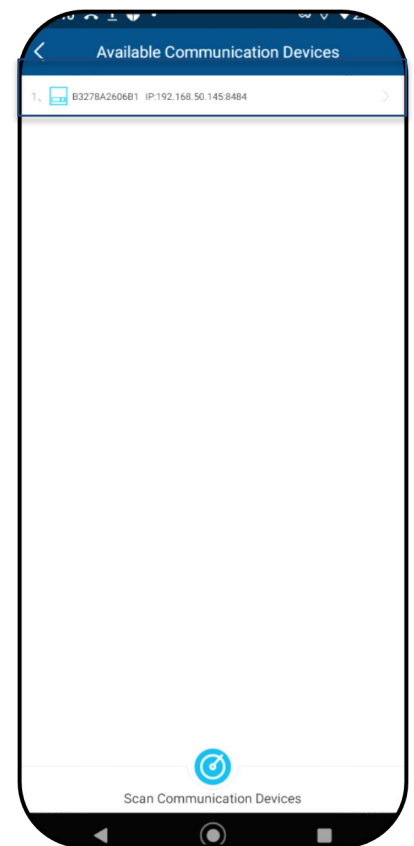

Fig. 77. Select operation mode

Fig. 78. Select inverter

9.11 Enabling functions



NOTE

You will find a description of the individual functions starting in Chapter 9.13.1 from page 40. Further parameters are also being added continuously in the successive firmware versions. For this reason, see the PDF version of these application instructions for important additions.

🔄 The <Communication unit> menu is opened.

1. Call up <Enable/disable functions> via <Settings for> under <Select inverter>.
2. After the setting has been made in the respective parameter, the function can be enabled (see references).
 - Active power regulation (see Chapter 9.13.6 on page 42)
 - 70 % rule (for details, see Chapter 9.17 on page 52)
 - Active power rampup (see Chapter 9.13.6 on page 42)
 - P(U) (see Chapter 9.13.8 on page 44)
 - P(f) (see Chapter 9.13.7 on page 43)
 - Reactive power control (see Chapter 9.13.9 on page 45)
 - LVRT (Low Voltage Ride Through) – This is a requirement that generation units remain on the grid and are not switched off in the event of a short-term voltage drop.
 - Overvoltage trip-off (10 min average) – protective function
 - Islanding detection – protective function
 - Monitoring of N-PE voltage – ground fault protective function
 - Active power increase with underfrequency P(f)
3. Confirm selection with <OK>. The device then performs a restart with the desired range of functions.
 - » The desired functions are permanently set.

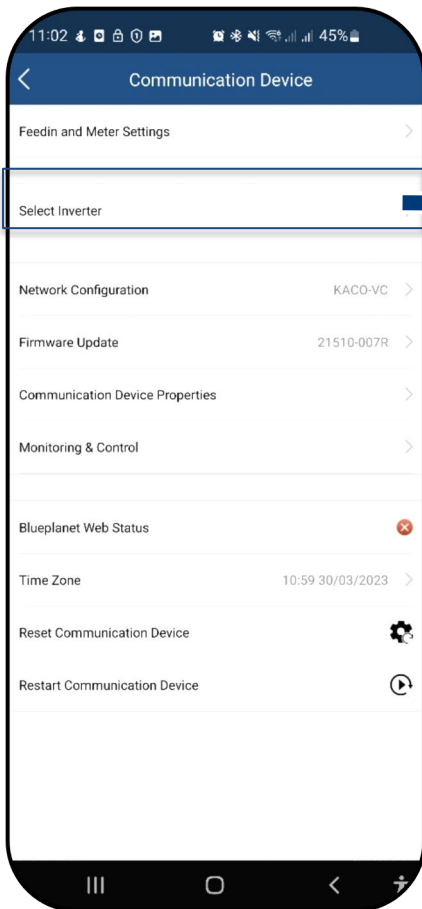

Fig. 79. Select inverter

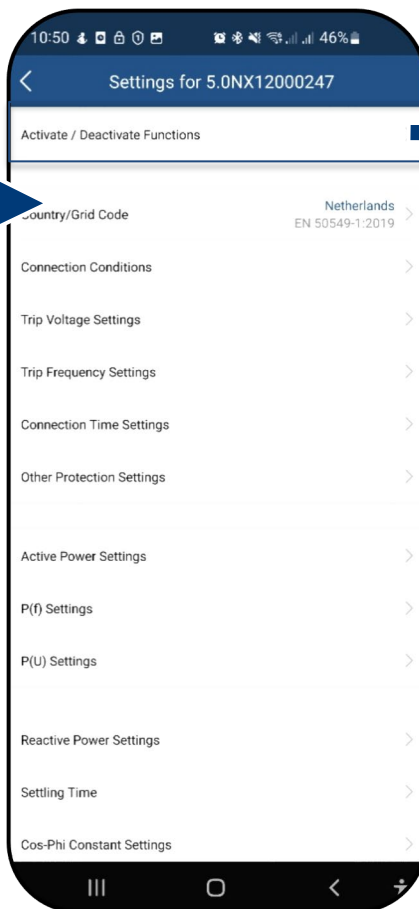

Fig. 80. Enable/disable functions

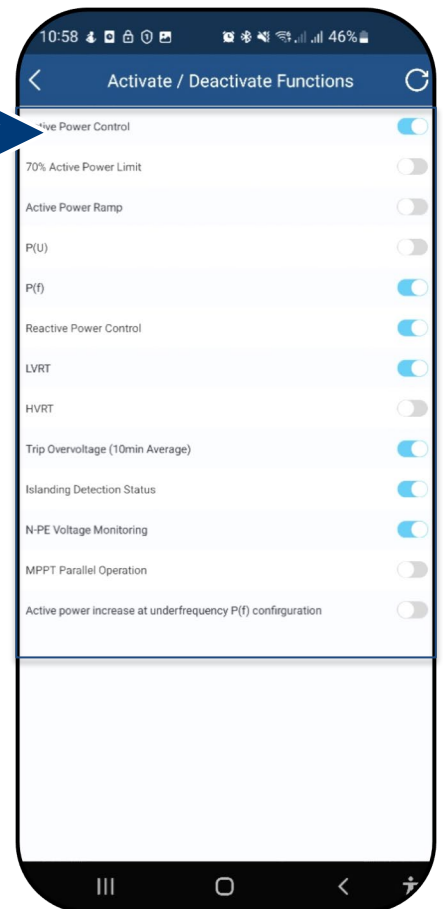

Fig. 81. Toggle required functions

9.11.1 Connection conditions

Note: The suitable voltage and frequency range for grid operation can be set in accordance with the requirements of the local grid operator.

The <Settings for> menu is opened.

Select <Connection conditions>.

Set parameters for min./max. start voltage and start frequency.

Save settings with <Confirm>.

Grid parameters set.

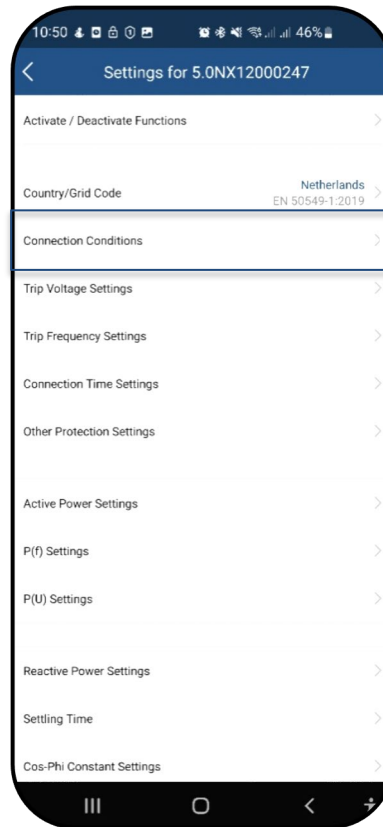

Fig. 82. Connection conditions

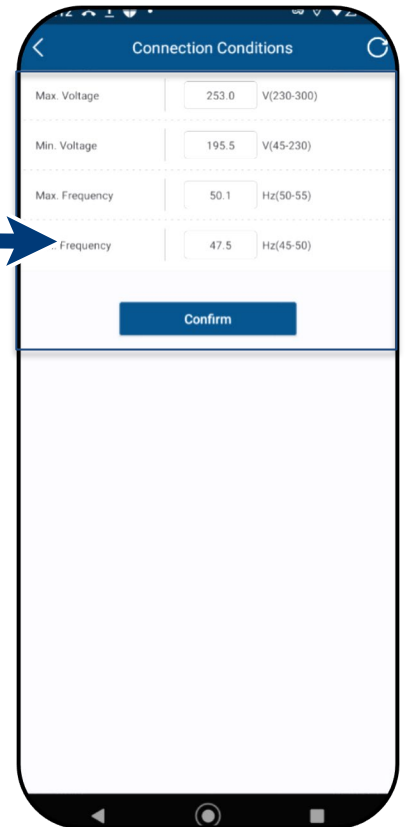

Fig. 83. Setting grid parameters

9.11.2 Voltage shutdown settings

Note: There are three thresholds for overvoltage and undervoltage protection. The first threshold value indicates the lower range. The middle threshold range is freely adjustable. The third threshold value indicates the upper range.

The <Settings for> menu is opened.

1. Select <Voltage shutdown settings>.

2. Set min. and max. shutdown time with associated voltage for each phase.

3. Save the settings with the <Confirm> button.

» Voltage protection defined.

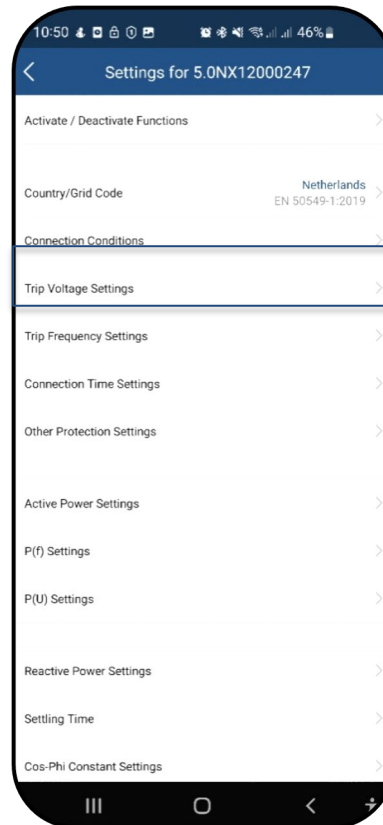

Fig. 84. Select voltage shutdown settings

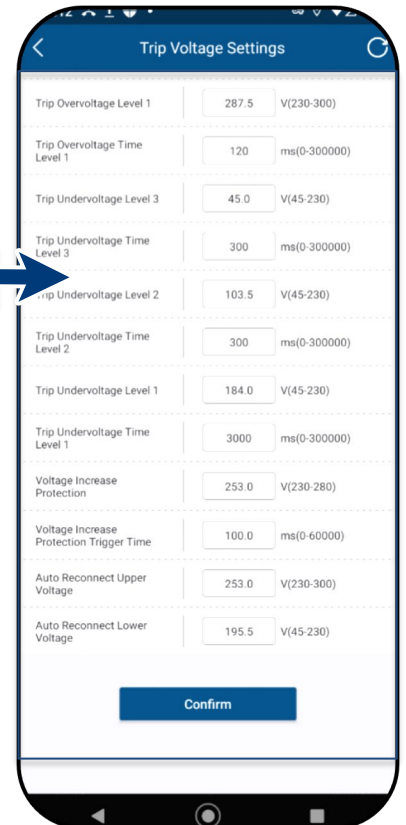

Fig. 85. Define voltage range and shutdown times

9.11.3 Frequency shutdown settings

Note: There are three thresholds for overfrequency and underfrequency protection. The first threshold value indicates the lower range. The middle threshold range is freely adjustable. The third threshold value indicates the upper range.

↻ The <Settings for> menu is opened.

1 Select <Frequency shutdown settings>.

2. Set the thresholds.

Principle:

- First maximum threshold \leq second maximum threshold \leq third maximum threshold
- First minimum threshold \geq second minimum threshold \geq third minimum threshold
- Trigger time for the first threshold \leq trigger time for the second threshold \leq trigger time for the third threshold

3. Save settings with <Confirm>.

» Frequency protection defined.

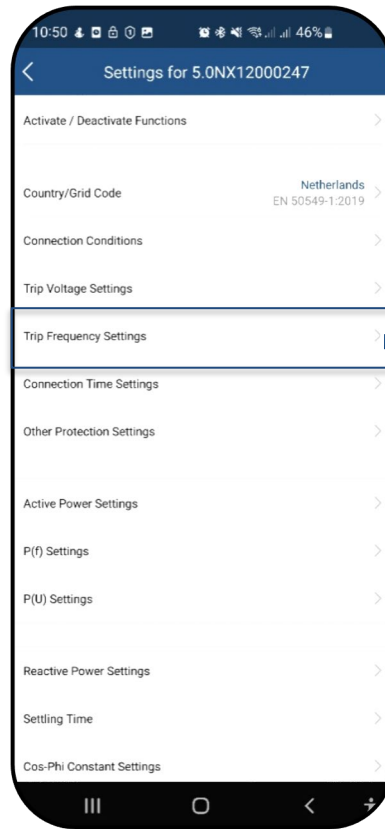

Fig. 86. Select frequency shutdown settings

Fig. 87. Set frequency range and ROCOF protection limit

9.11.4 Connection time settings

Note: Set monitoring time when one of the voltage and frequency values has been changed. If the measured values are within the range defined by the selected grid standard, the inverter can start or reconnect.

↻ The <Settings for> menu is opened.

1. Select <Connection time settings>.

2. Set <Start-up time> for restart.

3. Set <Reconnection time>.

4. <Confirm> settings.

» Connection time defined.

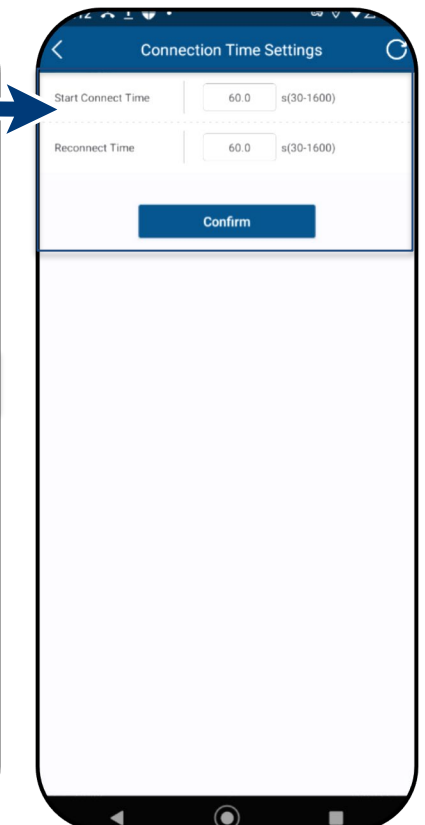
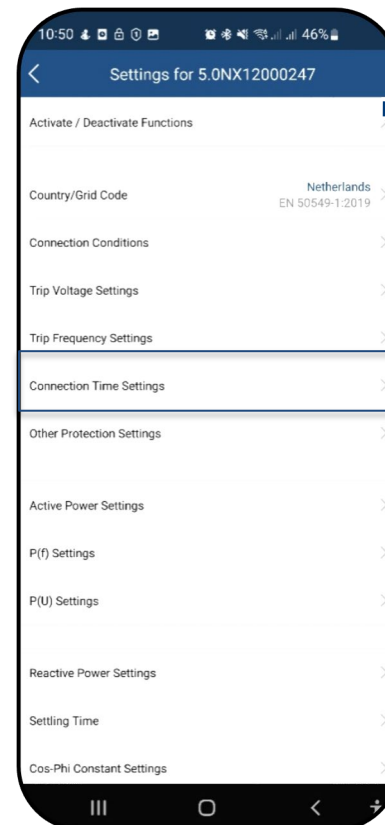

Fig. 88. Select connection time settings

Fig. 89. Define start-up / reconnection time

9.11.5 Other protective shutdowns

Note: Further protective settings must also be made to protect your PV array from damage.

↻ The <Settings for> menu is opened.

1. Select <Other protective shutdowns>.
 2. Specify the <insulation resistance>.
 3. Specify the <Max. DC feed-in current>.
 4. Set the <Max. DC feed-in duration> for error monitoring.
 5. Save settings with <Confirm>.
- » Protective function set

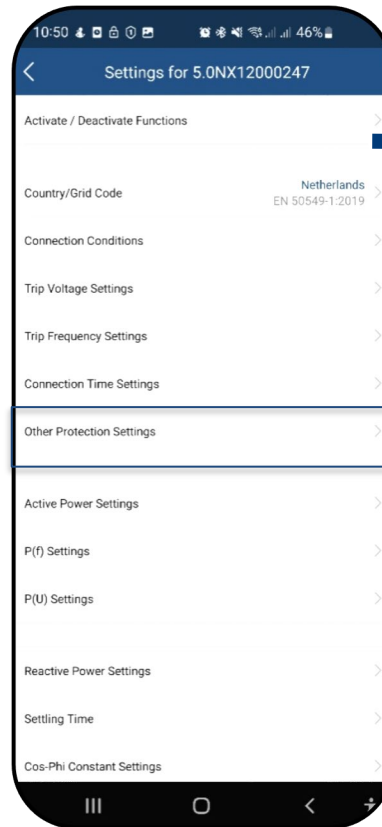

Fig. 90. Call up other protective shutdowns

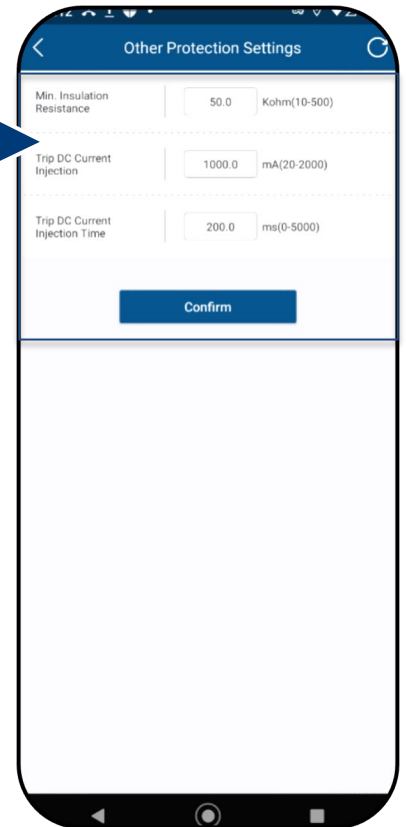

Fig. 91. Set insulation resistance and DC parameters

9.11.6 Active power settings (power limitation)

Note: The output power of the device can be set permanently to a lower value than the maximum output power by the power limitation. This may be necessary in order to limit the maximum power rating of the system at the grid connection point, upon the grid operator's request.

↻ The <Settings for> menu is opened.

1. Select <Active power settings>.
2. Set <Max. active power> dependent on Pn in %.
3. Set the <Increasing gradient> and <Decreasing gradient> of the active power.
4. Save settings with <Confirm>.

Note: When switching to AC operation and control and when switching to energy generation mode, the active power generated by the device must not exceed a certain gradient expressed as a percentage of the nominal active power of the inverter per minute.

» Power limitation defined.

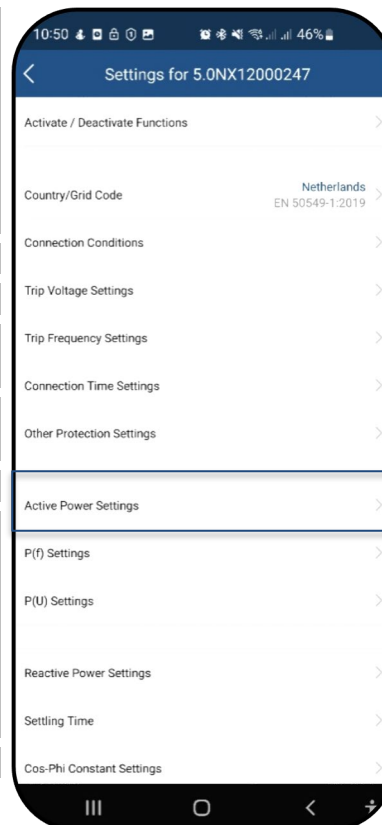

Fig. 92. Call up active power settings

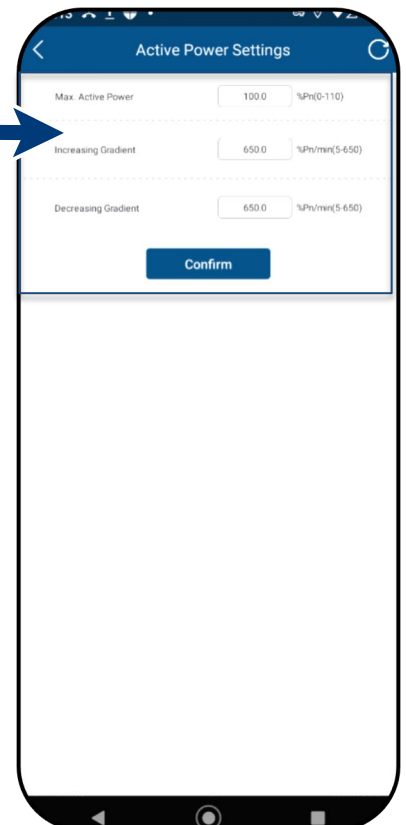

Fig. 93. Define max. AP & gradients settings

9.11.7 P(f) settings

Note: With a programmable frequency threshold with programmable P range, the inverter can activate the active power response to underfrequency.

↻ The <Settings for> menu is opened.

1. Select the <P(f) settings>.
 2. Select mode > see note below on the 4 modes.
 3. Define frequency range.
 4. Set relative power reduction.
 5. Set internal delay time P(f).
 6. Define min. delay time for power reduction.
 7. Define power gradient after resetting the frequency.
- » P(f) defined.

Legend for Fig. 96+Fig. 97: f_n : Nominal frequency; f_{reset} : Reset frequency; f_{start} : Start frequency; f_{stop} : Stop frequency; ΔP : Active power in % during reduction.

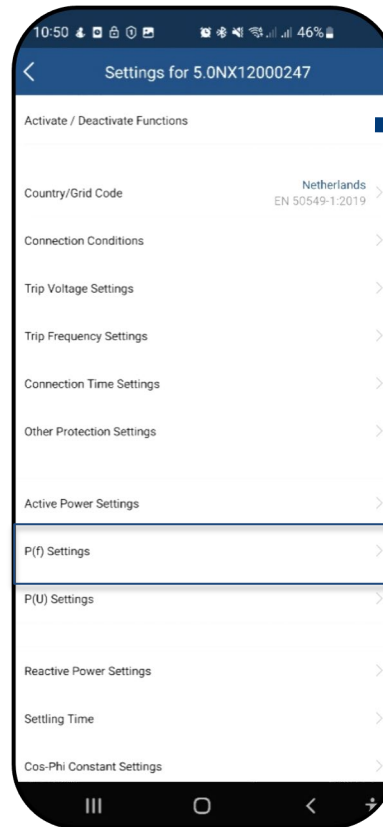

Fig. 94. Select the P(f) settings

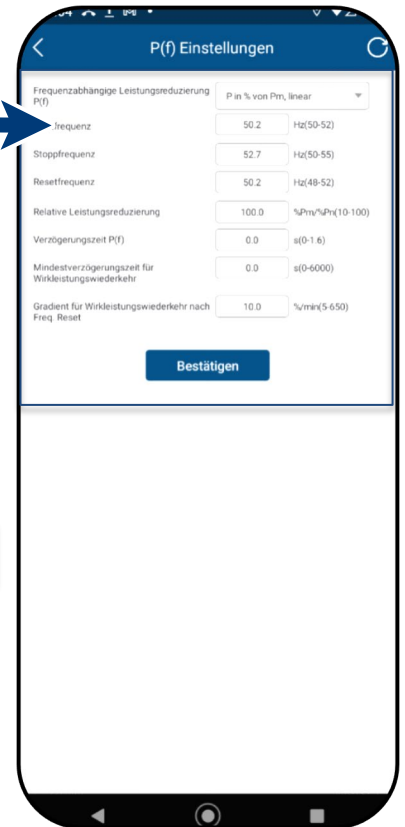

Fig. 95. Set the P(f) parameters

Note: The following 4 modes are available for selection:

1. Fixed gradient and non-hysteresis: ΔP is the active power as a percentage of P_n ; the inverter provides non-hysteresis in the control of active power response to overfrequency.
2. Variable gradient and non-hysteresis: ΔP is the active power as a percentage of P_M ; the inverter provides non-hysteresis in the control of active power response to overfrequency.
3. Fix gradient and hysteresis: ΔP is the active power as a percentage of P_n ; the inverter provides hysteresis in the control of active power response to overfrequency.
4. Variable gradient and hysteresis: ΔP is the active power as a percentage of the P_M ; the inverter provides hysteresis in the control of active power response to overfrequency.

Note: The intentional delay time for P(f) is only used for the activation of the function in accordance with the frequency via f_{start} , whereby the intentional delay time plus own dead time must be smaller than 2s.

Note: The minimum delay time for enabling of the active power is the delay time during which the active power can increase once the frequency has fallen below f_{reset} .

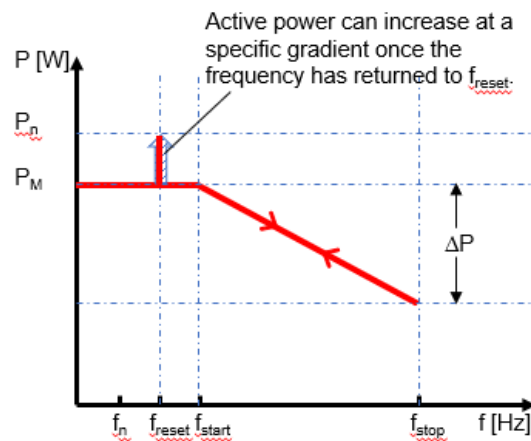

Fig. 96. Non-hysteresis

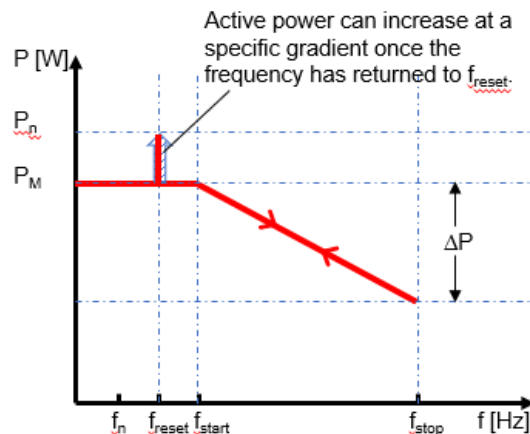

Fig. 97. Hysteresis

9.11.8 P(U) settings

Note: With a programmable voltage threshold with programmable P range, the inverter can activate the active power response to overvoltage.

↻ The <Settings for> menu is opened.

1. Select the <P(U) settings>.
 2. Select mode > see note below.
 3. Define voltage range.
 4. Define relative power reduction.
 5. Set internal delay time P(U).
 6. Define min. delay time for power reduction.
 7. Define power gradient after resetting the frequency.
- » P(U) defined.

Legend for Fig. 100+Fig. 101 U_n : Nominal voltage; U_{reset} : Reset voltage; U_{start} : Start voltage; U_{stop} : Stop voltage; ΔP : Active power in % during reduction.

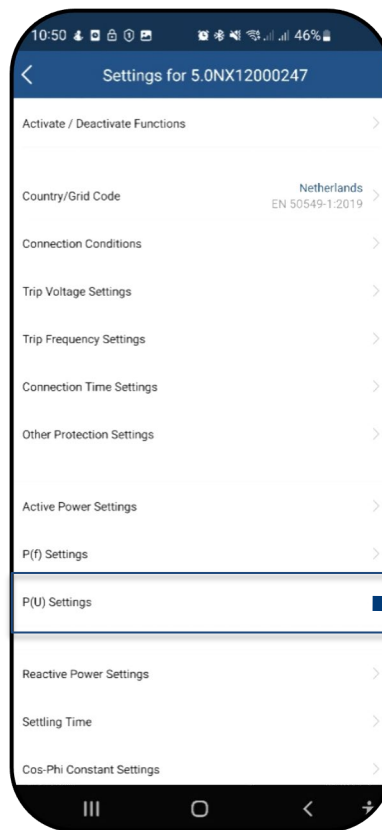

Fig. 98. Select the P(U) settings

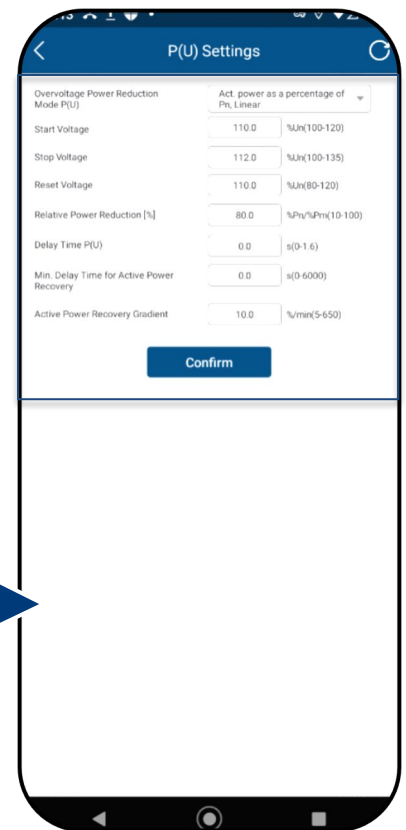

Fig. 99. Set the P(U) parameters

Note: The following 4 modes are available for selection:

1. Fix gradient and non-hysteresis: ΔP is the active power as a percentage of P_n ; the inverter provides non-hysteresis in the control of active power response to overvoltage.
2. Variable gradient and non-hysteresis: ΔP is the active power as a percentage of the P_M ; the inverter provides non-hysteresis in the control of active power response to overvoltage.
3. Fix gradient and hysteresis: ΔP is the active power as a percentage of P_n ; the inverter provides hysteresis in the control of active power response to overvoltage.
4. Variable gradient and hysteresis: ΔP is the active power as a percentage of the P_M ; the inverter provides hysteresis in the control of active power response to overvoltage.

Note: The intentional delay time for P(U) is only used for the activation of the function in accordance with the voltage via U_{start} , whereby the intentional delay time plus own dead time must be smaller than 2s.

Note: The minimum delay time for enabling of the active power is the delay time during which the active power can increase once the voltage has fallen below U_{reset} .

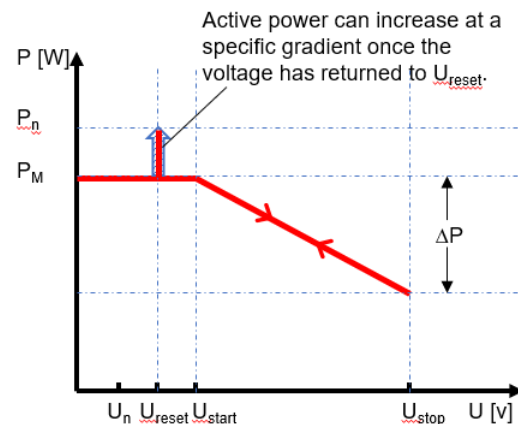

Fig. 100. Non-hysteresis

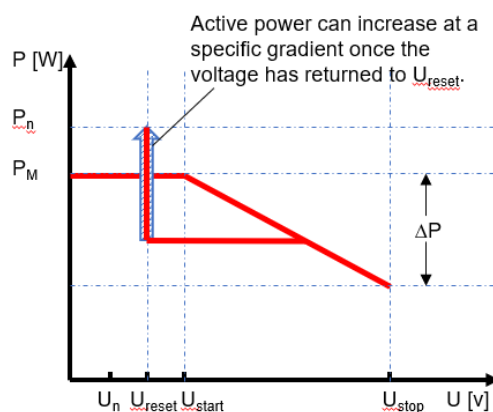

Fig. 101. Hysteresis

9.11.9 Reactive power operation mode

Note: Reactive power can be used in electrical energy supply networks to bolster the level of voltage. As such, feed-in inverters can contribute to statistical voltage stability.

↻ The <Settings for> menu is opened.

1. Select <Reactive power settings>.

2. Select control process > see basis and set subsequent processes <Cos-phi constant>, <Cos-phi(P)>, <Q constant>, <Q(U)>.

3. Set <Settling time setting> for selected control process.

Note: A change in the reactive power may be necessary in order to meet the requirements of a first-order filter.

» Reactive power process defined.

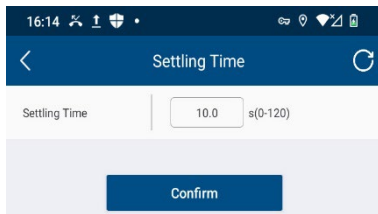

Fig. 102. Set the settling time

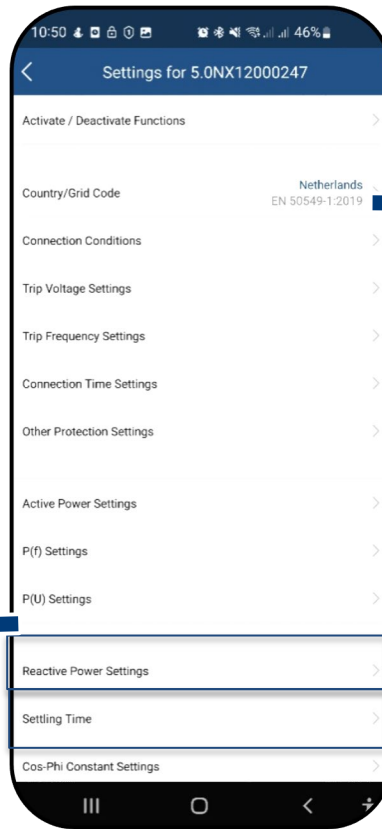

Fig. 103. Select reactive power settings

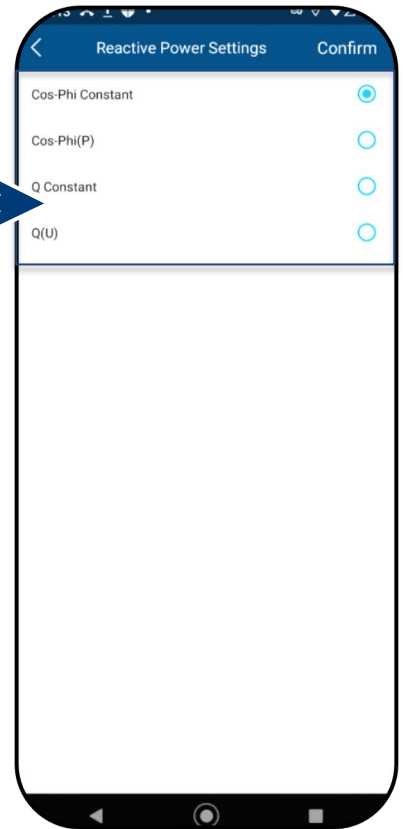

Fig. 104. Specify the operation mode settings

Basis

There are four types of reactive power control. Only one mode of operation can be active at any given moment.

From the perspective of the grid, the inverter behaves like a load in accordance with the national standard. This means that the inverter operates in quadrant II (under-excited) or III (over-excited) as shown in Fig. 105.

Definition

Over-excited reactive power, also known as capacitive reactive power or leading power factor.

Under-excited reactive power, also known as inductive reactive power or lagging power factor.

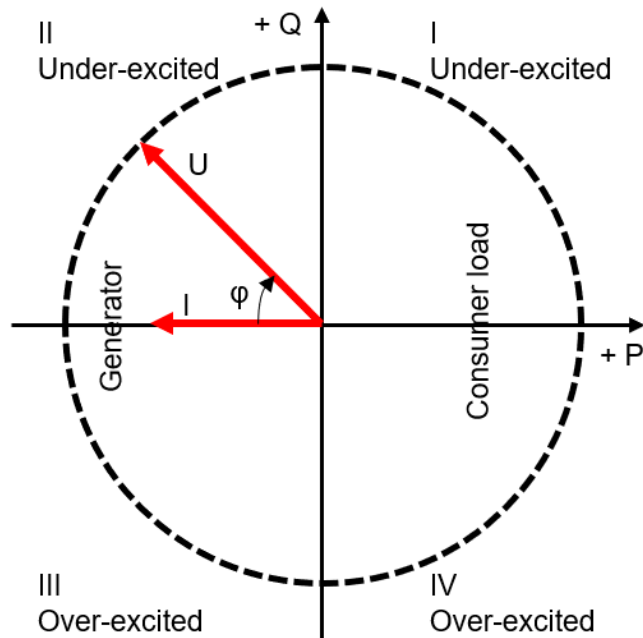

Fig. 105. Load reference arrow system

9.11.10 Cos-phi constant settings

Note: In $\cos \phi$ constant mode, the specified power factor is permanently set by the inverter. In doing so, the reactive power level is set in line with $Q=P \cdot \tan \phi$ as a function of the power that continuously generates the specified power factor.

The <Settings for> menu is opened.

1. Select <Cos-phi constant setting>.
 2. Set the <Cos-phi> target value.
 3. Select the excitation type from the drop-down field.
 4. Save settings with <Confirm>.
- » Cos-phi constant defined.

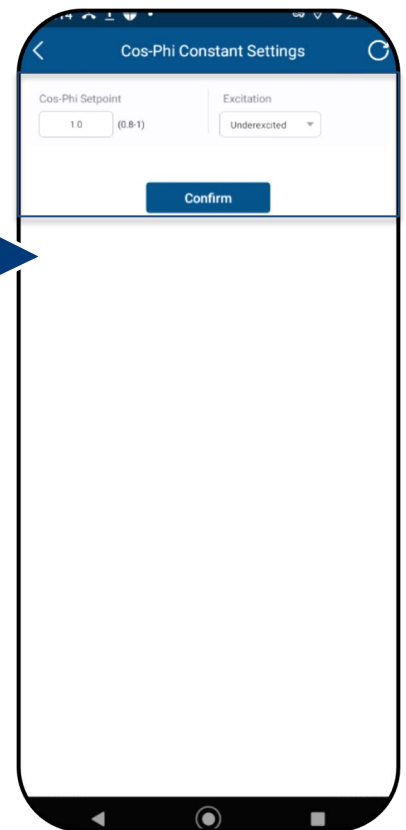
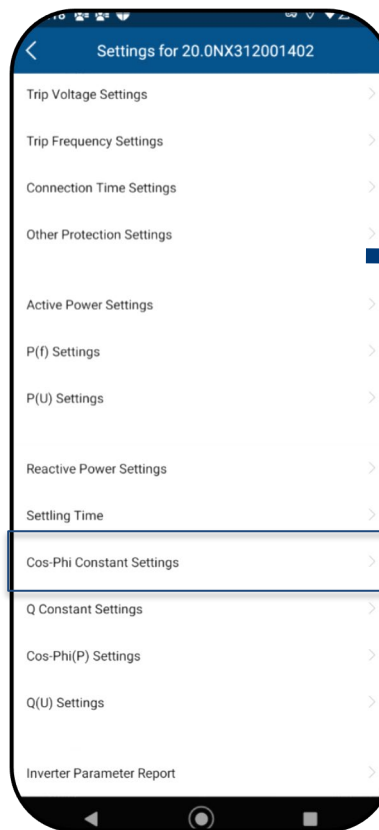

Fig. 106. Select the cos-phi constant

Fig. 107. Define the cos-phi target value

9.11.11 Q constant settings

Note: The target value of the reactive power can be adjusted depending on the set maximum apparent power.

The <Settings for> menu is opened.

1. Select <Q constant settings>.
 2. Set <Q> in %.
 3. Select the excitation type from the drop-down field.
 4. Save settings with <Confirm>.
- » Q constant> defined.

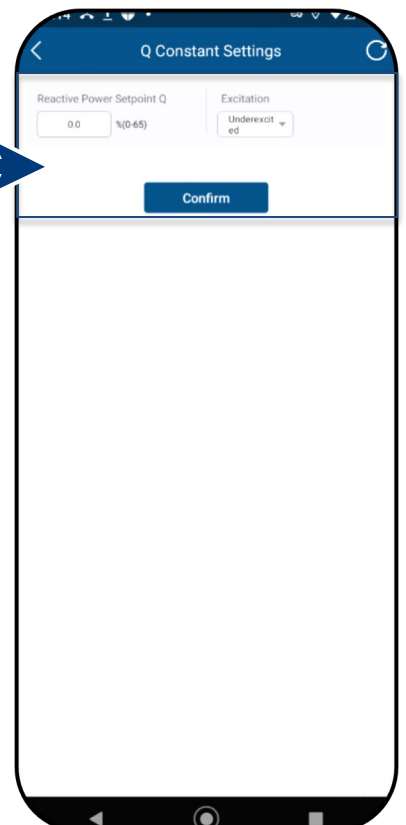
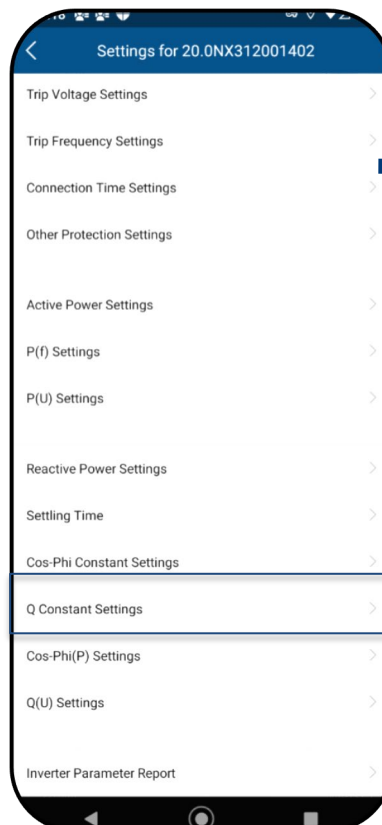

Fig. 108. Select Q constant settings

Fig. 109. Enter reactive power target value Q

9.11.12 Cos-phi (P) settings

Note: Power-based control $\cos \phi(P)$ regulates the $\cos \phi$ value of the power depending on the emitted active power.

4 coordinates can be set in order to map the P curve.

↻ The <Settings for> menu is opened.

1. Select <Cos-phi (P) settings>.
2. Define P/Pn, $\cos\phi$ and excitation for each of the 4 nodes.
3. Set the <Activation voltage>.

Note: Activation threshold as a percentage of U_n corresponds to the “Lock-In” voltage.

4. Set the <Deactivation voltage>.

Note: Deactivation threshold as a percentage of U_n corresponds to the “Lock-Out” voltage.

» $\cos \phi(P)$ defined.

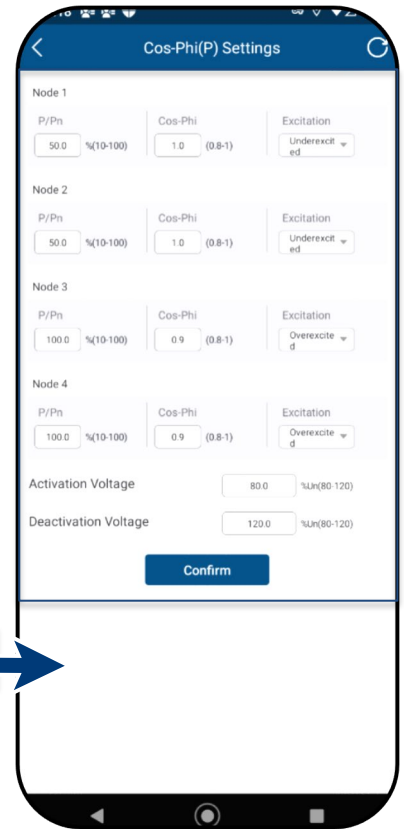
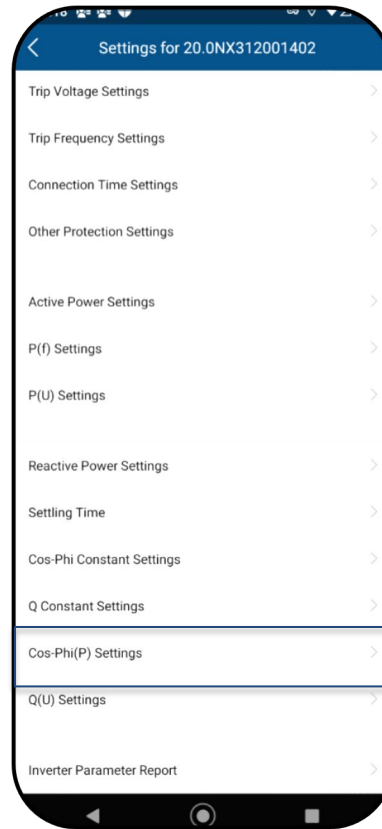

Fig. 110. Select cos-phi (P) settings

Fig. 111. Set cos-phi (P) parameters

Definition:

The coordinates are the active power as a percentage of P_n and the displacement factor $\cos\phi$.

A grid operator can specify two voltage thresholds as a percentage of P_n to activate or deactivate the function. The voltage thresholds are normally referred to as the “Lock-In” and the “Lock-Out” voltage.

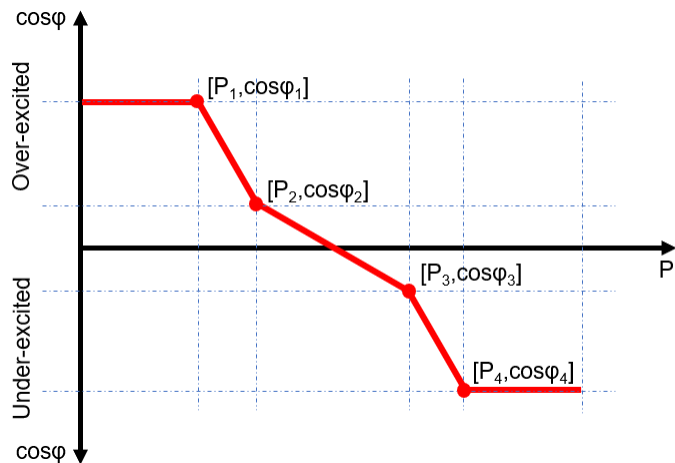

Fig. 112. Cos-phi(P) curve

9.11.13 Q(U) settings

Note: Voltage-dependent control Q(U) regulates the reactive power output depending on the voltage. 4 coordinates can be set in order to map the curve.

↻ The <Settings for> menu is opened.

1. Select the <Q(U) settings>.

2. Define U/Un, Q/Sn and phase for each of the 4 coordinates.

3. Set the <Activation power> in % of Pn.

Note: Activation threshold as a percentage of Pn corresponds to the “Lock-In” voltage.

3. Set the <Deactivation power> in % of Pn.

Note: Deactivation threshold as a percentage of Pn corresponds to the “Lock-Out” voltage.

» Q(U) curve defined.

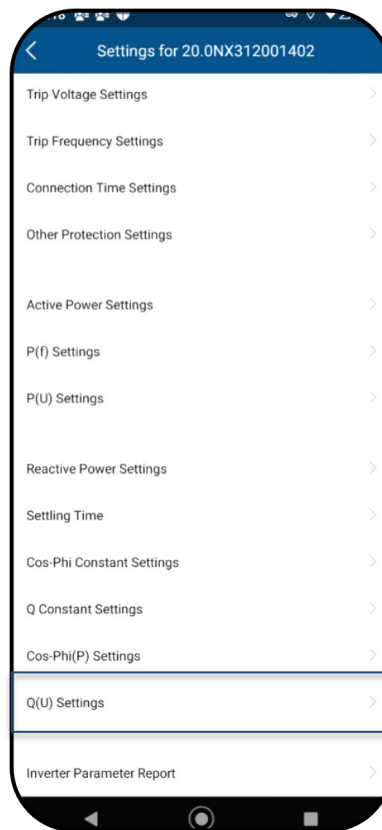

Fig. 113. Select Set Q(U) settings

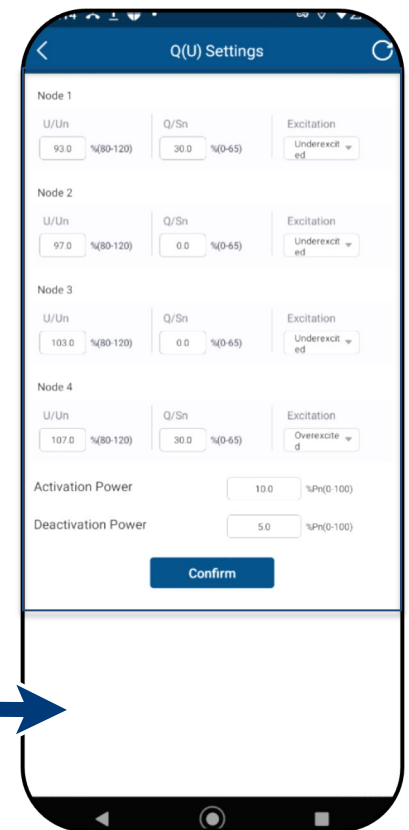

Fig. 114. Set the Q(U) parameters

Definition:

The coordinates are the voltage as a percentage of Un and the reactive power as a percentage of Pn.

A grid operator can specify two active power thresholds as a percentage of Un to activate or deactivate the function. The active power thresholds are normally referred to as the “Lock-In” and the “Lock-Out” active power.

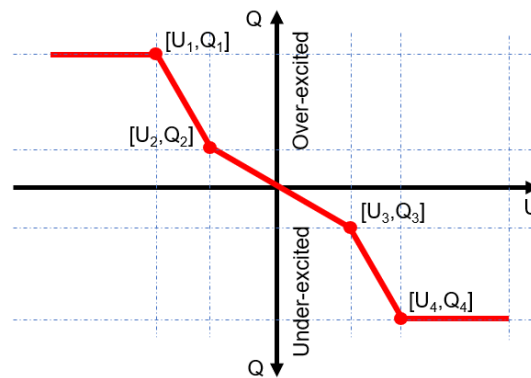

Fig. 115. Q(U) curve and non-hysteresis

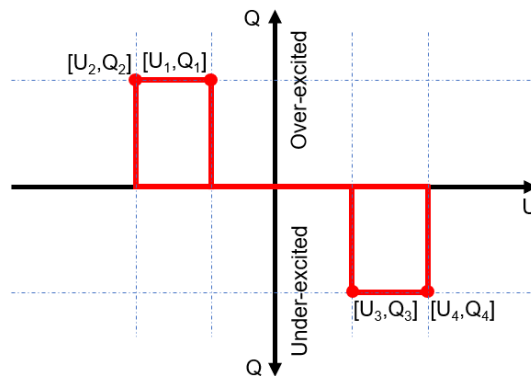

Fig. 116. Q(U) curve and hysteresis

9.11.14 Inverter parameter report

Note: Displays all set parameters in an overview list.

↻ The <Settings for> menu is opened.

1. Select <Inverter parameter report>.

2. Check all set parameters.

3. Export the set parameters using the <Export PDF> button. This serves as proof of all settings made with regard to the EVU.

» Parameter overview displayed.

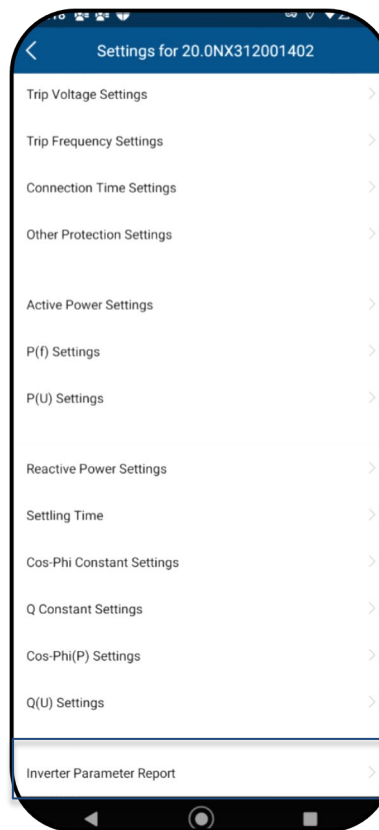

Fig. 117. View device parameters



Fig. 118. View all parameters

9.12 Performing a firmware update

9.12.1 Updating the Communication unit

Note: The enclosed Communication unit is required in order to perform the update. The firmware update can only be carried out with adequate DC voltage (100 W).

↻ The current firmware package is available at mykaco.com and does not correspond to the firmware version on the device(s).

1 Download the firmware “KACO_NX3_Vxx.zip” with the required *.bin files from mykaco.com under downloads and unpack.

2. Select <Firmware Update>

3. Select the tab <Communication unit> and press <Local upgrade>

4. In the firmware path, select the new file **Update.bin**.

» After successful update, continue with the inverter firmware update.

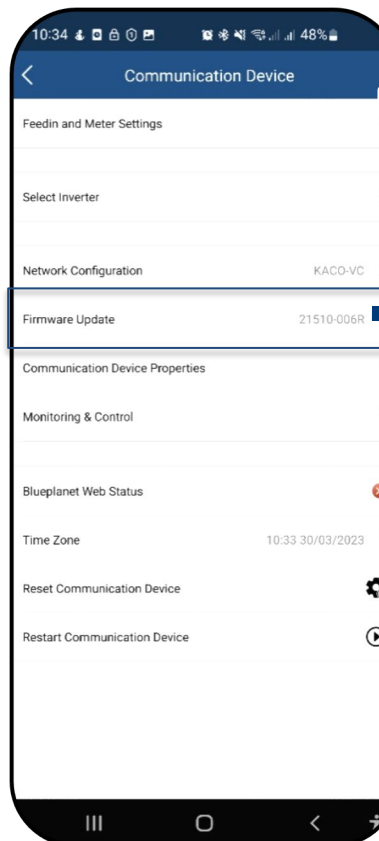

Fig. 119. Select firmware update

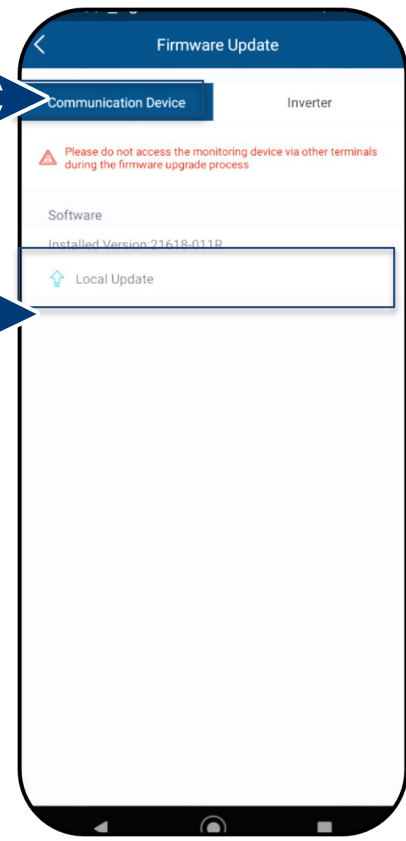

Fig. 120. Update the firmware for the Communication unit

9.12.2 Update the inverter



NOTE

Make sure that there is sufficient DC power (100 W). Also note that the sequence of the firmware update for the associated *.bin files must be observed. This process takes approx. 10 minutes. The files must not be renamed.

Before updating the inverter, the firmware of the Communication unit needs to be updated.



NOTE

With the Communication unit plugged in, no communication via RS485 is possible during the firmware update.

🔄 The firmware update for the Communication unit has been carried out successfully.

1. Select <Firmware Update>.
2. Select the <Inverter> tab and call up <Local upgrade> for inverters.
3. In the firmware path, locate and open the file **masterVxxx-xxxxx-xx.bin**. The upload begins.
6. Open <Local upgrade> for the <Safety> file.
7. In the firmware path, locate and open the file **safetyVxxx-xxxxx-xx.bin**. The upload begins.
8. After completing the update, check the uploaded firmware versions of each *.bin file against the version in your firmware path. Repeat the corresponding process if any deviation is found.
9. The upgrade process must be confirmed.

Caution: During the upgrade, the info – **Update in progress** – is displayed. Only **after restarting** the device does the message appear – **Update completed successfully**.

» Following successful update, the device is ready for operation.

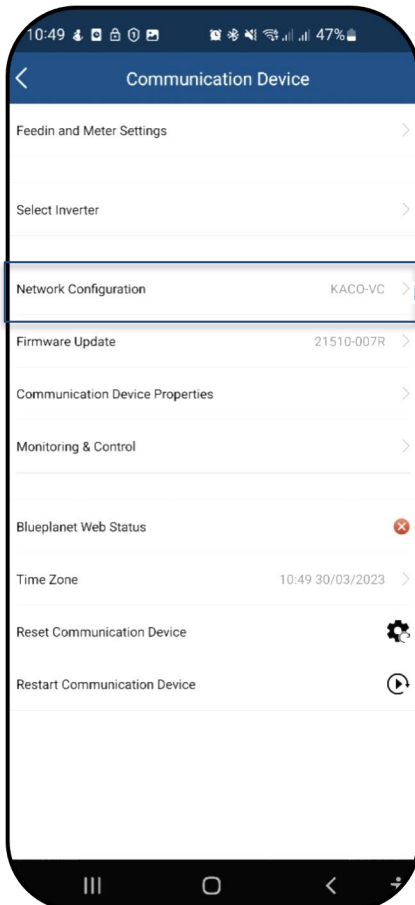

Fig. 121. Select firmware update



Fig. 122. Select firmware update for inverters



Fig. 123. Firmware for inverters and associated security update

9.13 Monitoring with “blueplanet web”

- ↳ <blueplanet web public> opened.
- Note:** You will find the portal under:
<https://kaco-newenergy.com/de/blueplanet-web/>.
- 1. Select “Register PV system free of charge in blueplanet web public”.
- 2. From the drop-down menu, select <blueplanet NX Series>.
- 3. Registration is carried out via the <Create new user> button, or with an existing account via <Login>.
- Note:** Data is transferred after approx. 30-60 minutes.
- Note:** After successful connection, the LED <blueplanet Web-Status> under <Communication unit> lights up **green**. (LED status – See Fig. 68 on Page36).
- Note:** The portal version <blueplanet web pro>, which is subject to a charge, offers a greater range of functions

blueplanet web public Registrierung

Mit diesem Formular können Sie Datenlogger zur Verwendung mit blueplanet web public registrieren.

1. Klicken Sie bitte auf "Neuen Benutzer anlegen" um einen neuen Zugang anzulegen.
2. Verfügen Sie bereits über einen Login klicken Sie bitte auf "Login".

blueplanet web public Kommunikation:

NOTE



Registration entry in the monitoring tool
 Depending on the software package on your device, o serial numbers may need to be entered!
SW package < R006 inverter serial number - Reg.
SW package > R006 serial number from WiFi stick-

▼ Data logger

Inverter serial number(s)*:

Fig. 124. Registering via KACO blueplanet web public

9.14 Monitoring the device

You can monitor the device via the external Communication unit. The operating data of the device can also be transferred to the cloud. You can also view all data with the “KACO NX Setup” app.

Each device has a communication unit. If the same devices are installed in the same location, the devices can be connected using the RS 485 cable and share a communication unit. Please note that a maximum of 5 devices can be connected to each Communication unit.

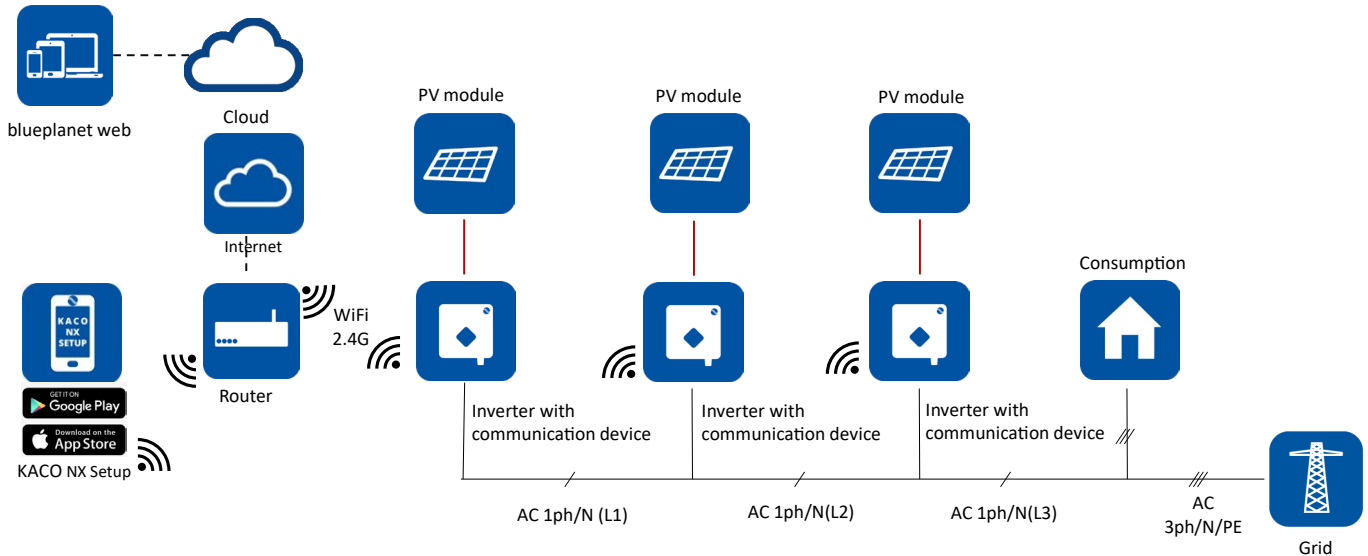

Fig. 125. Installation monitoring of up to 5 inverters with Communication unit

9.15 Active power control with a Smart-Meter

The device can control the active power delivered via a connected Smart-Meter. The following image shows the connection mode of the system via a communication unit.

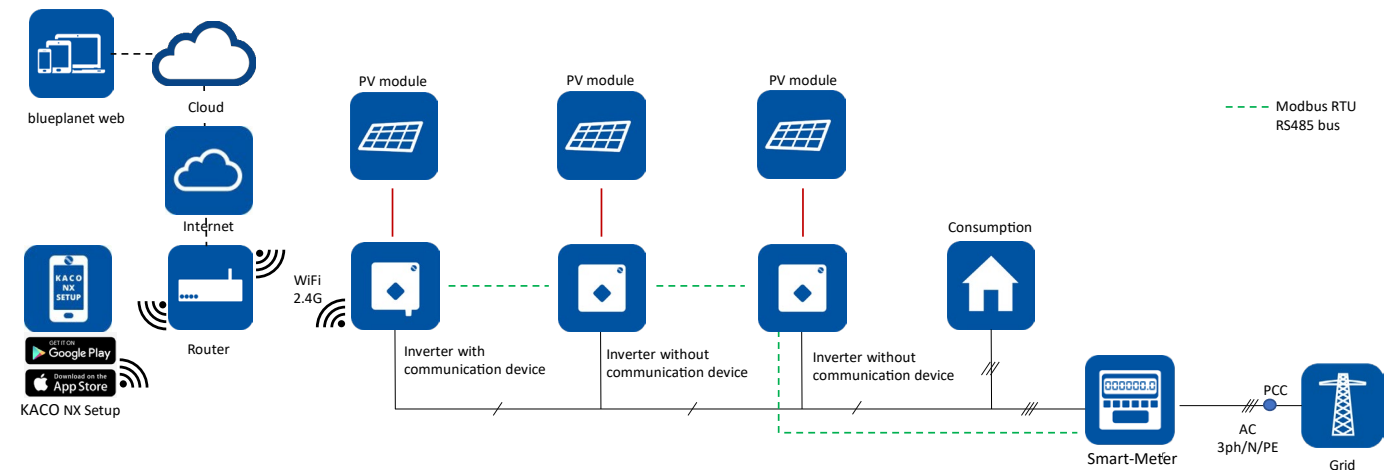

Fig. 126. System for active power control with Smart-Meter

Connection method with Smart-Meter as shown above via SDM630. For the Modbus and setting the baud rate method for ModBus, see the corresponding user manual.

9.16 Information on dynamic feed-in

9.16.1 Control behaviour

With a system output of 7 kWp and above, a digital feed-in meter or a remote control option is still mandatory at present. Active power limitation is the simplest option here. This can be achieved for all NX3 devices via the Smart-Meter or a data logger.

With EEG 2023, the expansion of photovoltaics is to become a topic of overriding public interest. Therefore, new PV systems that are connected to the grid on or after 1 January 2023 and have a capacity of up to 25 kW will be subject to the maximum generation. This involves abolishing the 70% limit on the nominal power that may be fed into the public grid. Consequently, a solar generation meter (Smart-Meter) is no longer necessary.

9.16.2 Increasing the active power limitation

For the feed-in limit to be raised above 70%, a smart meter or data logger must be connected. The total consumption is communicated to the inverter/data logger by the additional Smart-Meter (3-phase) so that it can establish a new maximum feed-in power.

If the feed-in power of a PV system is compared with the consumption of a detached home, a graph such as the following example is produced.

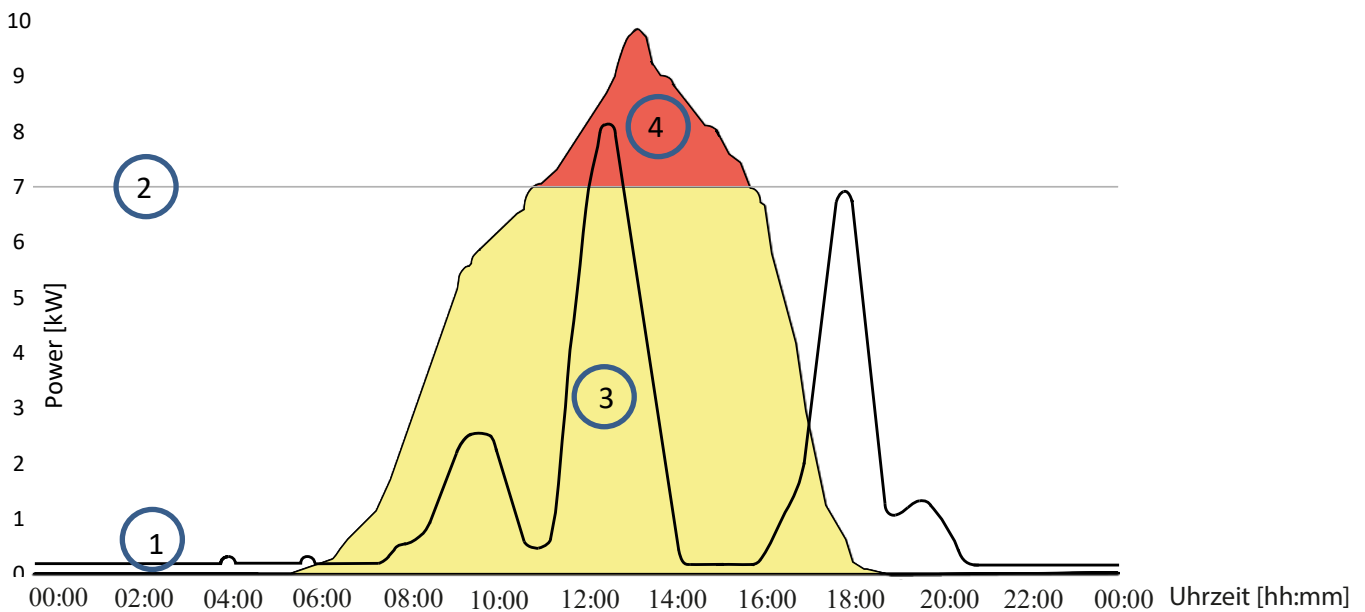

Fig. 127. Diagram comparing the energy requirement of a detached home and PV output

Legend			
1	Energy requirement of a detached home	3	70% feed-in power (yellow area)
2	70% fixed feed-in limit (grey line) – regulation command to inverter	4	Lost feed-in power (red area)

It is evident that there is a constant base load, especially at night (continuous/standby operation of consumers).

Based on this graph, we can now see that the actual self consumption values communicated should result in considerably less power being lost from the PV system.

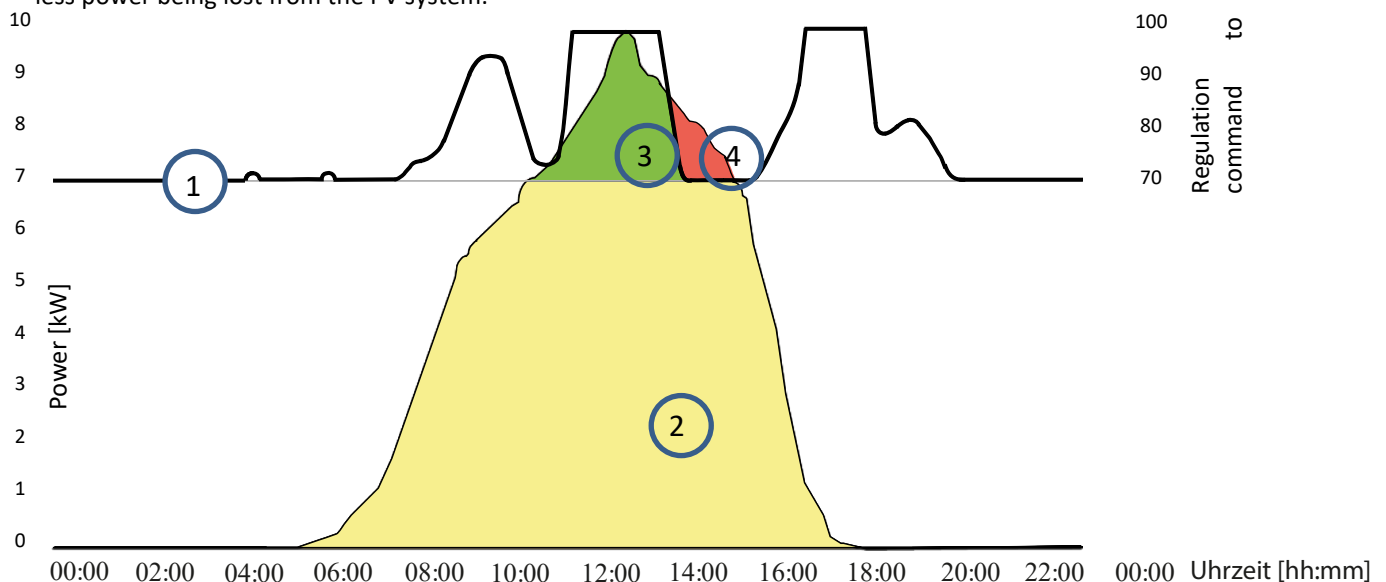

Fig. 128. Diagram of increase in self consumption

Legend			
1	Regulation command to device 70% + self consumption	3	PV power gained through self consumption
2	Energy requirement of a detached home (green area)	4	PV power lost despite self consumption

Using the feed-in meter/data logger for calculations allows more efficient use to be made of the PV system, thus providing more energy for self-consumption.

Graph Abb. 145 also shows that a red area (lost energy) is nevertheless produced because the amount of power consumed by the owner has fallen to 0 but the PV system could provide more electricity. When the self consumption falls to 0 kW, the 70% regulation function takes effect again.

The 0% feed-in regulation, on the other hand, must ensure that there is no feed into the public grid. Depending on the self consumption, the PV system output may be connected up in such a way that the user can make use of the energy generated themselves and nothing has to be purchased from the public grid.

The feed-in meter must therefore be connected to the data logger so that the logger can generate the regulation commands. If an energy meter is not connected to the data logger, the logger continuously sends a regulation command to the inverters with a 0% feed-in maximum. This means that feed-in may not take place.

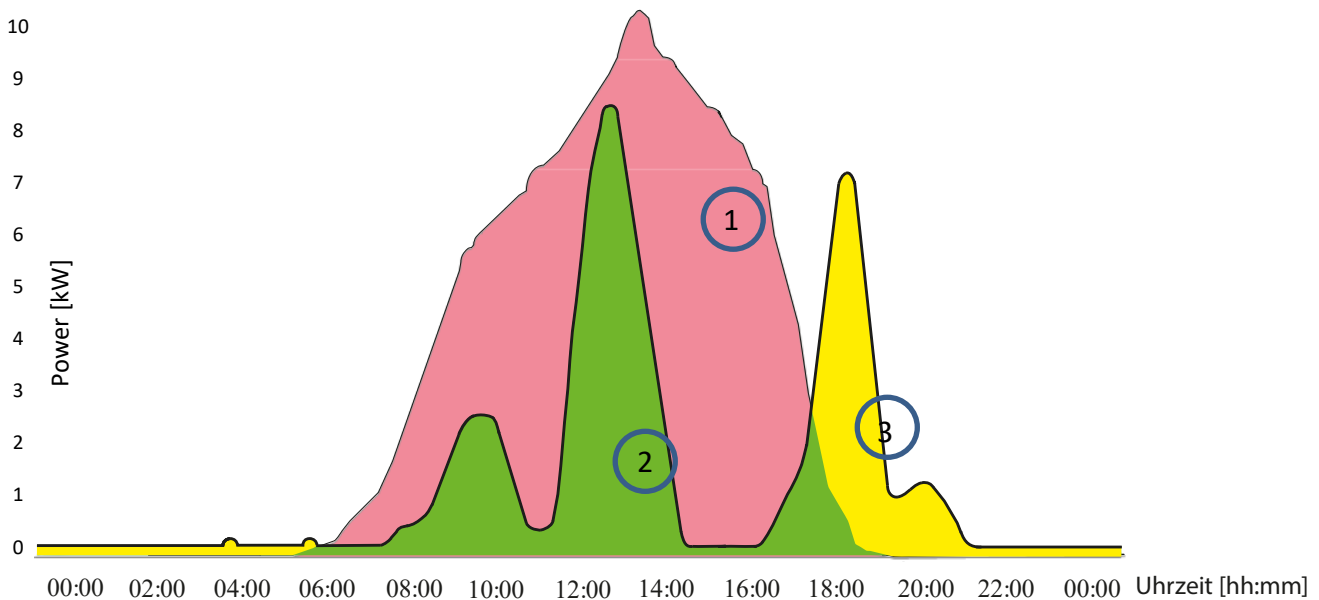

Fig. 129. Diagram of 0% regulation

Legend			
1	PV power available (red area)	3	Bought-in power (yellow area)
2	Energy requirement of a detached home (green area)		

By connecting up additional consumers, heating, water or energy storage systems, the self consumption and therefore the consumption of the PV current can be increased considerably.

This function can however only be used by data logger because this has an S0 output and could therefore connect up additional consumers via a relay circuit.

10 Maintenance and troubleshooting

10.1 Visual inspection

Inspect the product and cables for visible external damage and note the operating status display, where applicable. In case of damage, notify your installer. Repairs may only be carried out by an electrician.

DANGER



Dangerous voltage due to two operating voltages!

Removing the plug connections before disconnecting the device from the PV generator may lead to injuries and damage the device.

- › During installation: Electrically disconnect the DC positive and DC negative from the protective earth (PE).
- › Disconnect the device from the PV generator using the integrated DC isolator switch.
- › Remove the plug connector.

DANGER



Dangerous voltage due to two operating voltages

Coming into contact with the lines and/or terminals/busbars in the device can cause serious injury or death. The discharge time of the capacitors is up to 5 minutes.

- › Only appropriately qualified electricians authorised by the mains supply network operator are permitted to open and maintain the device.
- › Before opening the device: Disconnect the AC and DC side and wait at least 5 minutes.

NOTE



The housing of the device does not contain any components which can be repaired by the customer.

Do not attempt to repair faults that are not described here (in the chapter on troubleshooting and fault rectification). Contact our customer service department. Only perform the maintenance work that is described here.

The device should be checked for proper operation by a qualified electrician at regular intervals and if you experience problems, you should always contact the system manufacturer's Service department.

10.2 Cleaning

10.2.1 Cleaning the housing

DANGER



Danger of death due to penetrating fluid

Serious injuries or death can result if moisture enters the system.

- › Only use completely dry objects to clean the device.
- › The device should only be cleaned from the outside.

CAUTION



Do not use compressed air or high-pressure cleaners!

- › If the device is contaminated, only clean the housing, cooling fins, housing cover with water and a cloth.

1 Use a vacuum cleaner or a soft brush to remove dust from the top of the device on a regular basis.

2 Remove dust from the ventilation inlets if necessary.

10.2.2 Cleaning the heat sink

The housing of the device does not contain any components that can be repaired by the customer.

Do not attempt to repair faults that are not described here (in the chapter on troubleshooting and fault rectification). Contact our customer service department. Only perform the maintenance work that is described here.

The device should be checked for proper operation by a qualified electrician at regular intervals and if you experience problems, you should always contact the system manufacturer's Service department.

↻ Device switched off at integrated DC isolator switch and AC switch.

↻ Keep a suitable brush ready for cleaning.

1 Clean the free space between the cover and the heat sink using suitable brushes.

2 Clean the heat sink for the air inlet and outlet with a suitable brush.

NOTE: Do not use any aggressive cleaning agents and ensure that no other components come into contact with fluids.

» Cleaning completed



NOTE

Refer to our service and guarantee conditions on our website.

- The cleaning intervals must be adapted to the environmental conditions of the installation site.
- › In sandy environments, we recommend cleaning the heat sinks every three months.

10.3 Shutting down for maintenance work / troubleshooting

DANGER



Lethal voltages are still present in the connections and cables of the device even after the device has been switched off and disconnected!

Coming into contact with the lines and/or terminals/busbars in the device can cause serious injury or death.

Only appropriately qualified electricians authorised by the mains supply network operator are permitted to open and maintain the device.

- › Comply with all safety regulations and current technical connection specifications of the responsible power supply company.



NOTE

If the error status lamp lights up, follow the instructions in the Chapter 10.5 on page 57.

↻ NOTE: Shutdown sequence.

1 Switch off the grid voltage by turning off the external circuit breakers.

2 Switch off the DC supply using the DC isolator switch.

DANGER! The DC cables are still live!

» After shutdown, wait 5 minutes before replacing the device.

10.4 Troubleshooting

In <Communication unit properties>, a pending error is displayed under <Live values>. The error relates to the connected <Master inverter>

Error code	"N/A" is displayed here if no error has occurred.
------------	---

10.5 Error code

The following solutions are recommended when the error code is displayed:

No.: '	Description
Step	LED not illuminated/no power output
1	Make sure that the DC isolator switch on the device is in the "1" or "ON" position.
2	Use a multimeter to check the polarity of PV+ and PV-. The red measuring probe is connected to the positive pole, the black probe to the negative pole. The value should be positive.
3	Using the multimeter, check whether the DC voltage lies within the voltage range of the inverter or not.
4	Make sure that the DC solar plug connection is not loose.
5	Use an energy meter or a clamp meter to check whether the inverter starts up. If the device starts up, the cause may be an internal short-circuit in the communication cable.

No.: '	Description
Step	AC/DC terminals melted
1	It is necessary to tighten the terminals in order to establish the connection. Then, use external force to check whether the connection has loosened.
2	Take care that the cables and terminals are not subjected to excessive loads.

No.: E03-E05	Description
Step	E03: Relay test failed E05: Result of the automatic test function failed
1	Disconnect device via the AC isolator switch and measure the AC voltage with a multimeter. The voltage between the line and the neutral conductor should be approx. 230 V and the voltage between the neutral conductor and earth within 20 V.
2	If the measured voltage is abnormal, the error is caused by the system voltage. If the measured voltage is normal, please switch the AC isolator switch on and continue with the next step.
3	Measure the AC voltage UL1-N, UL2-N, UL3-N, UN-PE using a multimeter.
4	If the measured voltage is normal, there is an error in the device. Please contact customer service to replace the device.
5	If the measured voltage is abnormal, please check the isolator switch and the cable (wiring error, loose connection, short-circuit, insulation etc.).

No.: E46	Description
Step	High MPPT voltage value
1	When installing the device, measure the DC voltage with a multimeter to ensure that the voltage lies within the MPPT voltage range.
2	If the DC voltage exceeds the MPPT voltage range, please reconfigure the PV modules. If the DC voltage is within the MPPT voltage range, please replace the device.
3	If the error is reported for a limited period of time and the device regenerates, the cause is the detection of abnormal device data.
4	If the device does not recover, please switch the DC and AC power supply off, wait 5 minutes and then restart. If the error cannot be remedied, please replace the inverter.

No.: E34/E48	Description
Step	E34: AC voltage outside the range E48: Average voltage of the last ten minutes fault
1	Switch the AC isolator switch off and measure the AC voltage. The voltage between the line and the neutral conductor should be approx. 230 V and the voltage between the neutral conductor and earth within 20 V.
2	If the measured voltage is abnormal, the error is caused by the grid voltage. If the measured voltage is normal, please switch the isolator switch on and continue with the next step.
3	Measure the AC voltage UL1-N, UL2-N, UL3-N, UN-PE using a multimeter.
4	If the measured voltage is normal, there is an error in the device. Please contact customer service to replace the device.
5	If the measured voltage exceeds the safety requirements, please check the system voltage.

No.: E35	Description
Step	Loss of supply power
1	If the device error disappears and the device can be connected to the grid, please check whether an circuit breaker is installed on the AC side.
2	If the error occurs constantly, please disconnect the AC circuit breaker and measure the AC voltage. The voltage between the line and the neutral conductor should be approx. 230 V and the voltage between the neutral conductor and earth within 20 V.
3	If the measured voltage is lower than 20 V, the error is caused by the system voltage. If the measured voltage is normal, please switch the circuit breaker on and continue with the next step.
4	Measure the AC voltage UL1-N, UL2-N, UL3-N, UN-PE using a multimeter.
5	If the measured voltage is normal, there is an error in the device. Please contact customer service to replace the device. If the measured voltage exceeds the safety requirements, please check the system voltage.

No.: E36/E38	Description
Step	E36-GFCI failure / E38--ISO error
1	This error occurs if the device determines that the system leakage current exceeds the requirements of the safety standards (200k Ohms).
2	Please check whether the fault occurs in wet and rainy weather. Also check whether the fault disappears when the weather is dry and sunny. If this is not the case, the device is not the cause of the fault.
3	Using a multimeter, check whether the voltage PV+ and PV+ to earth is normal. It should be half of PV+ and PV-. Connect the strings individually to check which string is causing the error.
4	Carry out a visual inspection of all PV strings and connections and make sure that the grounding is reliable.
5	If there is a device of the same model in operation on site, use it to replace the failed device and check whether the failure was caused by the device.

No.: E37	Description
Step	PV overvoltage
1	This error occurs if the device determines that the DC input voltage exceeds the maximum DC voltage of the device.
2	Remove all strings from the device and use the multimeter to measure the voltage between PV+ and PV- for each string. The total voltage must not exceed the maximum DC voltage of the device.
3	If the measured voltage is normal, there may be an error in the device. Please contact customer service to replace the device.

No.: E40	Description
Step	Overtemperature in the device
1	This error occurs when the sensor detects a high temperature in the device.
2	Check for foreign bodies in the fan or heat sink of the device which could be the cause of overtemperature in the device.
3	Please check the ambient temperature when installing the device (below 40 °C) and do not expose the device to sunlight. If the error cannot be remedied, please contact customer service to replace the device.

No.: E65	Description
Step	PE connection error
1	This error occurs when the inverter detects overvoltage in the N-PE.
2	Using the multimeter, measure the N-PE voltage of the device.
3	Ensure that N and PE are not reversed.
4	If necessary, deactivate the <Monitoring N-PE voltage> function (See Fig. 81 on Page 39) in the APP to hide the error message.

No.: W165	Description
Step	PE connection error
1	This error occurs when the inverter detects overvoltage in the N-PE.
2	Using the multimeter, measure the N-PE voltage of the device.
3	Ensure that the earth cable is firmly connected and that the connection area is sufficient.
4	If the error persists, please contact KACO new energy customer service.

10.6 Fault during connection set-up and search

Note: If there is a timeout or a communication failure with its WLAN network, the APP may freeze in an unwanted manner.

We recommend the following approach:

- Check the WLAN connection on the mobile end device. If the connection has been lost, reactivate it in the device settings. The window of the “KACO NX Setup” APP has to be closed completely using the overview of all opened windows, so that the “KACO NX Setup” APP can be restarted.
- If necessary, restart the search using the “Scan” button.
- If the QR code is not recognized, a manual connection to the Communication unit can be established in the settings of the WLAN connection on the mobile end device. SSID: Serial number WIFI stick, password: Registration code (both printed on WIFI stick) see Fig. 38

Note: The current connection status can also be checked using the LEDs on the WIFI stick. To do this, check the signal status by referring to Chapter 9.5 on Page 27

» Faults have been corrected and the status LED on the Communication unit lights up continuously, signalling readiness for operation.

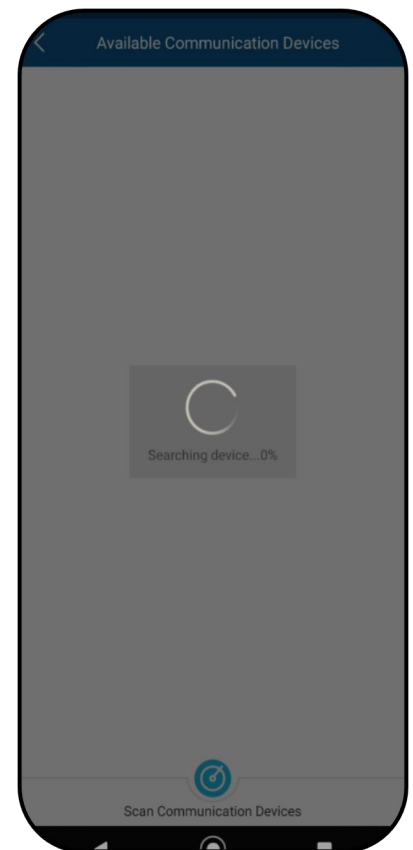

Fig. 130. Fault during connection & search

10.7 Disconnecting connections

10.7.1 AC connection

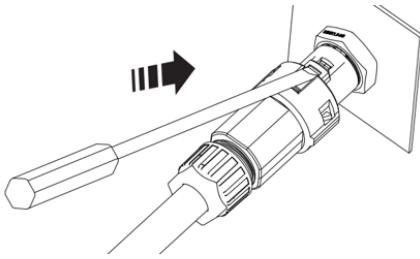

Fig. 131. Detach AC connection plug

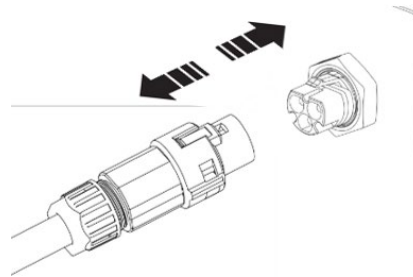

Fig. 132. Disconnect AC connection plug

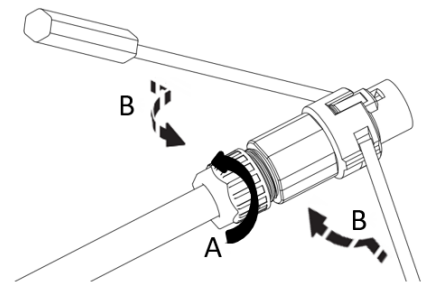

Fig. 133. Detach cable

⌚ Ensure that the device is completely free of AC/DC voltage.

- 1 Use a screwdriver (blade size 3 mm) to push in the catch on the coupling.
- 2 Unlock the plug connection and pull out the connector.
- 3 Unscrew the cable fitting.
- 4 Use a screwdriver to unlock the contact carrier on both sides.
- 5 Remove the contact carrier from the housing.
- 6 Loosen the screws on the contact carrier and remove the wires.

10.7.2 DC connection

 **DANGER**



Risk of DC plug connectors being destroyed!

DC plug connectors can be destroyed by an arc event if disconnected while still live. It is absolutely essential that the following shutdown sequence be carried out in the correct order:

- › Use a clip-on ammeter to check that there is no current in any DC cables.

⌚ Ensure that the device is completely free of AC/DC voltage.

⌚ › Check that there is no current with a clip-on ammeter.

⌚ NOTE: Plug connectors may be unplugged under voltage, but never under load.

- 1 Use a screwdriver (blade width 3 mm) to push out the catch on the coupling.
- 2 Leave the screwdriver in place.
- 3 Disconnect the DC connector from the DC socket.

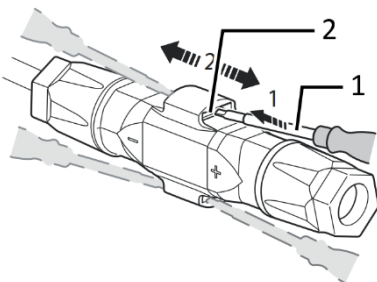

1 Screwdriver

2 Catch

Fig. 134. Detach AC connection plug

11 Decommissioning and dismantling

11.1 Switching off the device

DANGER

Lethal voltages are still present in the connections and cables of the device even after the device has been switched off and disconnected!

Coming into contact with the lines and/or terminals/busbars in the device can cause serious injury or death.



- › The device must be mounted in a fixed position before being connected electrically.
- › Comply with all safety regulations and current technical connection specifications of the responsible power supply company.
- › The device is only permitted to be opened or serviced by a qualified electrician.
- › Switch off the grid voltage by turning off the external circuit breakers.
- › Check that all AC and DC cables are completely free of current using a clip-on ammeter.
- › Do not touch the cables and/or terminals/busbars when switching the device on and off.
- › Keep the device closed when in operation.

DANGER

Risk of DC plug connectors being destroyed!



DC plug connectors can be destroyed by an arc event if disconnected while still live. It is absolutely essential that the following shutdown sequence be carried out in the correct order:

- › Use a clip-on ammeter to check that there is no current in any DC cables.

WARNING

Risk of burns caused by hot housing components



Housing components can become hot during operation.

- › During operation, only touch the housing cover on the device.

11.2 Uninstalling the device

DANGER

Dangerous voltage due to two operating voltages



Coming into contact with the lines and/or terminals/busbars in the device can cause serious injury or death. The discharge time of the capacitors is up to 5 minutes.



- › Only appropriately qualified electricians authorised by the mains supply network operator are permitted to open and maintain the device.

 Device disconnected and secured against restart.

- 1 Disconnect the AC connection plug from the device. AC connection [see section 10.6.1 on page 61]
 - 2 Detach the DC cables from the DC plug connectors and furnish with protective caps. DC connection [see Section 10.6.2 on page 61]
 - 3 Disconnect the Communication unit.
 - 4 If present, remove the accessories: **NX1 Smart Meter Connection Kit** in reverse order as described in Chapter 7.8.
- »The device has been uninstalled. Proceed with disassembly

11.3 Disassembling the device

↻ Unit has been switched off and uninstalled.

1 Remove the screw that prevents the device from being lifted off the mount.

2 Use the lateral openings and lift the device off the mount.

» Device removed. Proceed with the packaging process.

11.4 Packaging the device

↻ Device has been uninstalled.

1 If possible, always pack the device in the original packaging. If this is no longer available, an alternative is to use equivalent packaging.

2 The packaging box must be fully sealable and suitable for the weight and size of the device.

11.5 Storing the device

CAUTION



Property damage as a result of condensation

Incorrect storage can cause condensate to form in the device and impair the functionality of the device (e.g., storage outside the ambient conditions or temporary relocation from a cold to a hot environment).

- Store in accordance with the technical data > environmental data.
- Prior to installation, check the inner area for condensation and if necessary, allow it to dry sufficiently before installation.

↻ Device packaged.

Store the device in a dry place in accordance with the ambient temperature range specified in the environmental data.

12 Disposal

CAUTION



Risk to the environment if disposal is not carried out in the correct manner

For the most part, both the device and the corresponding transport packaging are made from recyclable raw materials.

Unit: Defective devices and accessories must not be disposed of with household waste. Ensure that the old devices and any accessories are disposed of in a proper manner.

Packaging: Ensure that the transport packaging is disposed of properly.

13 Service and warranty

If you need help solving a technical problem with one of our KACO products, please contact our service hotline. Please have the following information ready so that we can help you quickly and efficiently:

- Device name / serial number
- Date of installation / Start-up report
- Error message shown on the display / Description of the error / Did you notice anything unusual? / What has already been done to analyse the error?
- Module type and string circuit
- Consignment identification / Delivery address / Contact person (with telephone number)
- Information about the accessibility of the installation site.

You will find the following information and other information on our website www.kaco-newenergy.com.

- our current warranty conditions,
- a complaint form,
- a form for registering your device. Please register your device without delay. In this manner, you can assist us in providing you with the quickest service possible.

14 Appendix

14.1 EU Declaration of Conformity

EU-Konformitätserklärung

Name und Anschrift des Herstellers	KACO new energy GmbH Werner-von-Siemens-Allee 1 74172 Neckarsulm, Deutschland	
Produktbezeichnung	Photovoltaik-Netzeinspeise-Wechselrichter	
Typenbezeichnung	KACO blueplanet 3.0 NX1 M2 WM OD II90	[1002015]
[KACO Art. Nr.]	KACO blueplanet 3.7 NX1 M2 WM OD II90	[1002016]
	KACO blueplanet 4.0 NX1 M2 WM OD II90	[1002017]
	KACO blueplanet 5.0 NX1 M2 WM OD II90	[1002018]

Der oben beschriebene Gegenstand der Erklärung entspricht den einschlägigen gesetzlichen Bestimmungen, die in der Richtlinie des Europäischen Union vom 26. Februar 2014 zur Angleichung der Rechtsvorschriften der Mitgliedstaaten über die elektromagnetische Verträglichkeit (2014/30/EU), den Niederspannungsrichtlinien (2014/35/EU) sowie vom 16. April 2014 der Funkanlagenrichtlinie (2014/53/EU) festgelegt sind.

Der Gegenstand entspricht den folgenden Normen:

RED 2014/53/EU	Gerätesicherheit
„Richtlinie des Europäischen Parlaments und Rates vom 16. April 2014 über die Harmonisierung der Rechtsvorschriften der Mitgliedstaaten über die Bereitstellung von Funkanlagen auf dem Markt und zur Aufhebung der Richtlinie 1999/5/EG“	EN 62109-1:2010 EN 62109-2:2011
	Störfestigkeit
	EN 61000-6-1:2007 EN 61000-6-2:2005
	Störaussendung
	EN 55011:2016+A1:2017 group 1, Class B EN 61000-6-3:2007 + A1:2011 + AC:2012 EN 61000-6-4:2007 + A1:2011
	Netzurückwirkungen
	EN 61000-3-2:2014 EN 61000-3-3:2013 EN 61000-3-11:2000 EN 61000-3-12:2011
	Sicherheit und Gesundheit
	EN 62311:2018
	Effektive Nutzung des Frequenzspektrums
	EN 300 328 V2.2.2:2019
2011/65/EU	RoHS
„Richtlinie zur Beschränkung der Verwendung bestimmter gefährlicher Stoffe in Elektro- und Elektronikgeräten“	EN IEC 63000:2018 (Technische Dokumentation zur Beurteilung von Elektro- und Elektronikgeräten hinsichtlich der Beschränkung gefährlicher Stoffe)

Zusätzlich wurden folgende einschlägige Normen angewandt:

Störfestigkeit und Störaussendung
EN 62920:2017
Elektromagnetische Verträglichkeit
EN 301 489-1 V2.1.1
EN 301 489-17 V3.1.1

Die oben genannten Typen werden daher mit dem CE-Zeichen gekennzeichnet.

Bei eigenmächtigen Änderungen an den gelieferten Geräten und/oder nicht bestimmungsgemäßer Verwendung erlischt die Gültigkeit dieser Konformitätserklärung.

Diese Konformitätserklärung ist unter der alleinigen Verantwortung der KACO new energy GmbH ausgestellt.

Neckarsulm, 03.08.2021
KACO new energy GmbH

Neckarsulm, 03.08.2021
KACO new energy GmbH

**Haag
Matthias**
Digital signiert von Haag
Matthias
DN: cn=Haag Matthias,
o=DE, o=Siemens,
email=matthias.haag@kaco-
newenergy.de
Datum: 2021.08.05
15:36:20 +02'00'

i.V. Matthias Haag
Head of R&D and Technology

**Kittel
Thomas**
Digital signiert von Kittel
Thomas
DN: cn=Kittel Thomas,
o=Siemens,
email=thomas.kittel@kaco-
newenergy.de
Datum: 2021.08.05 15:40:18
+02'00'

i.V. Thomas Kittel
Head of Quality Management



The text and figures reflect the current technical state at the time of printing. Subject to technical changes. No liability for printing error



3014853-03-230420