

Building connections that last™



# Sharpe® Series 17

## Butterfly Valve Datasheet



# Butterfly Valve Sharpe® Series 17



## Design Features

- 200 psi Rating (2" - 12")  
150 psi Rating (14" - 48")
- Epoxy Coated Ductile Iron Body
- 416 Stainless Steel Stem
- Pinless Disc & Stem Design (2" - 12")
- Bi-Directional
- Suitable for Dead End Service (Lug only)
- For Use with Class 125 or 150 Flanges
- Seat Design Eliminates the Need for Flanged Gaskets
- ISO 5211 Mounting Pad
- MSS SP-25 Markings
- MSS SP-67
- API 609



asc-es.com

Building connections that last™

# Butterfly Valve Sharpe® Series 17

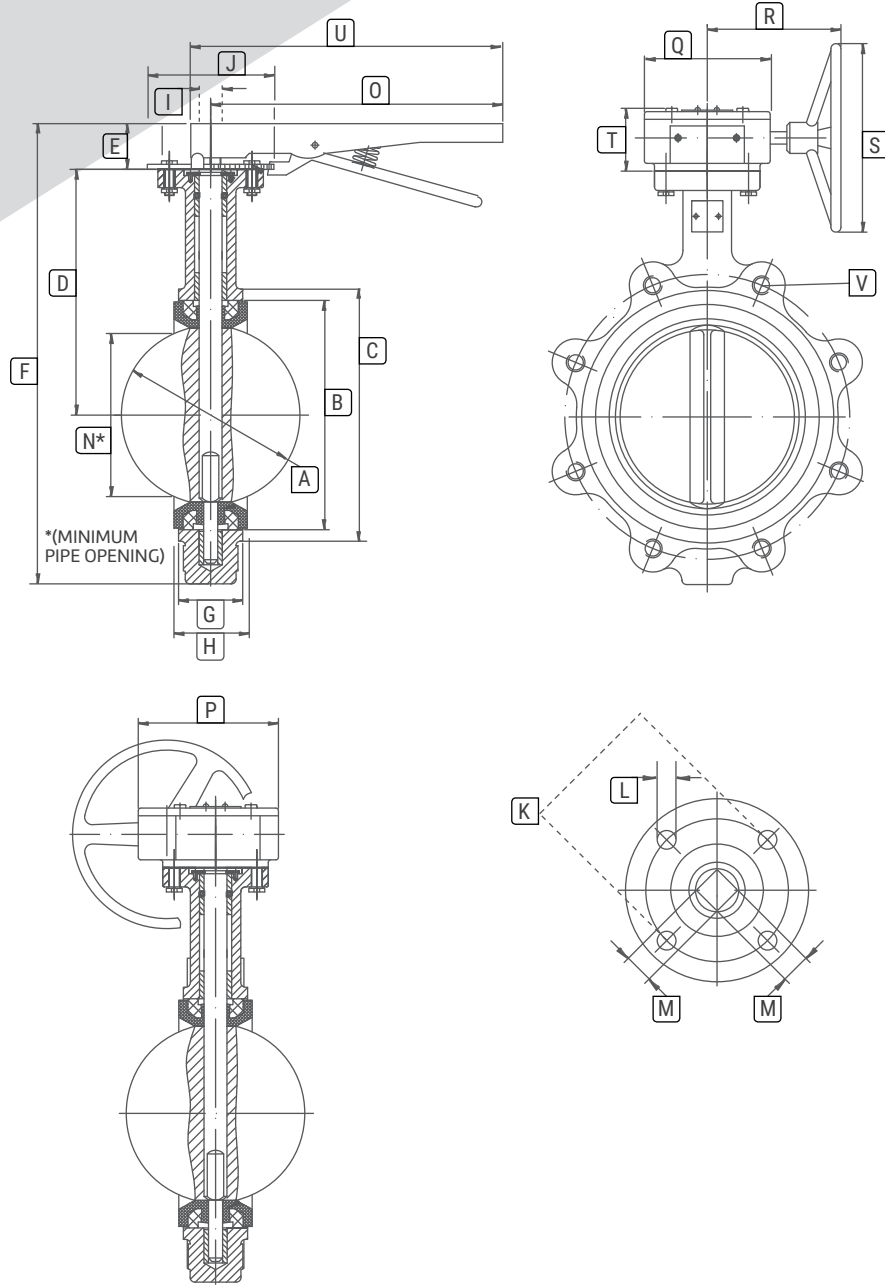

## Dimensions (Sizes 2" — 12")

Size	A	B	C	D	E	F	G	H	I	J	K	L	M	N	O	P	Q	R	S	T	U	V Lug	V Wafer
2	2.08	3.00	3.50	6.33	1.26	10.74	1.65	1.77	0.49	2.56	1.96	0.27	0.35	1.27	6.39	3.90	4.13	6.10	5.90	2.67	7.21	5/8-11 UNC	0.74
2-½	2.53	3.50	4.25	6.89	1.26	11.65	1.76	1.87	0.49	2.56	1.96	0.27	0.35	1.81	10.50	3.90	4.13	6.10	5.90	2.67	11.36	5/8-11 UNC	0.74
3	3.10	4.01	4.72	7.12	1.26	12.12	1.78	1.93	0.49	2.56	1.96	0.27	0.35	2.53	10.50	3.90	4.13	6.10	5.90	2.67	11.36	5/8-11 UNC	0.74
4	4.09	5.31	5.90	7.87	1.26	13.62	2.05	2.15	0.62	3.54	2.76	0.39	0.43	3.39	10.50	3.90	4.13	6.10	5.90	2.67	11.36	5/8-11 UNC	0.74
5	4.85	6.26	7.12	8.38	1.26	14.64	2.14	2.28	0.74	3.54	2.76	0.39	0.55	4.35	10.50	3.90	4.13	6.10	5.90	2.67	11.36	3/4-10 UNC	0.88
6	6.12	7.41	8.18	8.89	1.26	15.63	2.19	2.30	0.74	3.54	2.76	0.39	0.55	5.30	10.50	3.90	4.13	6.10	5.90	2.67	11.36	3/4-10 UNC	0.88
8	7.97	9.37	10.23	10.23	1.77	18.89	2.38	2.49	0.87	4.92	4.01	0.47	0.67	7.57	14.21	5.61	6.02	8.74	11.81	2.67	15.63	3/4-10 UNC	0.88
10	9.86	11.51	12.59	11.49	1.77	21.26	2.58	2.75	1.12	4.92	4.01	0.47	0.86	9.51	19.64	5.61	6.02	8.74	11.81	2.67	21.06	7/8-9 UNC	1.00
12	11.87	13.54	14.76	13.26	1.77	22.80	3.02	3.15	1.24	5.51	4.01	0.47	0.86	11.48	19.64	6.24	6.37	8.38	11.81	2.67	21.06	7/8-9 UNC	1.00

# Butterfly Valve Sharpe® Series 17

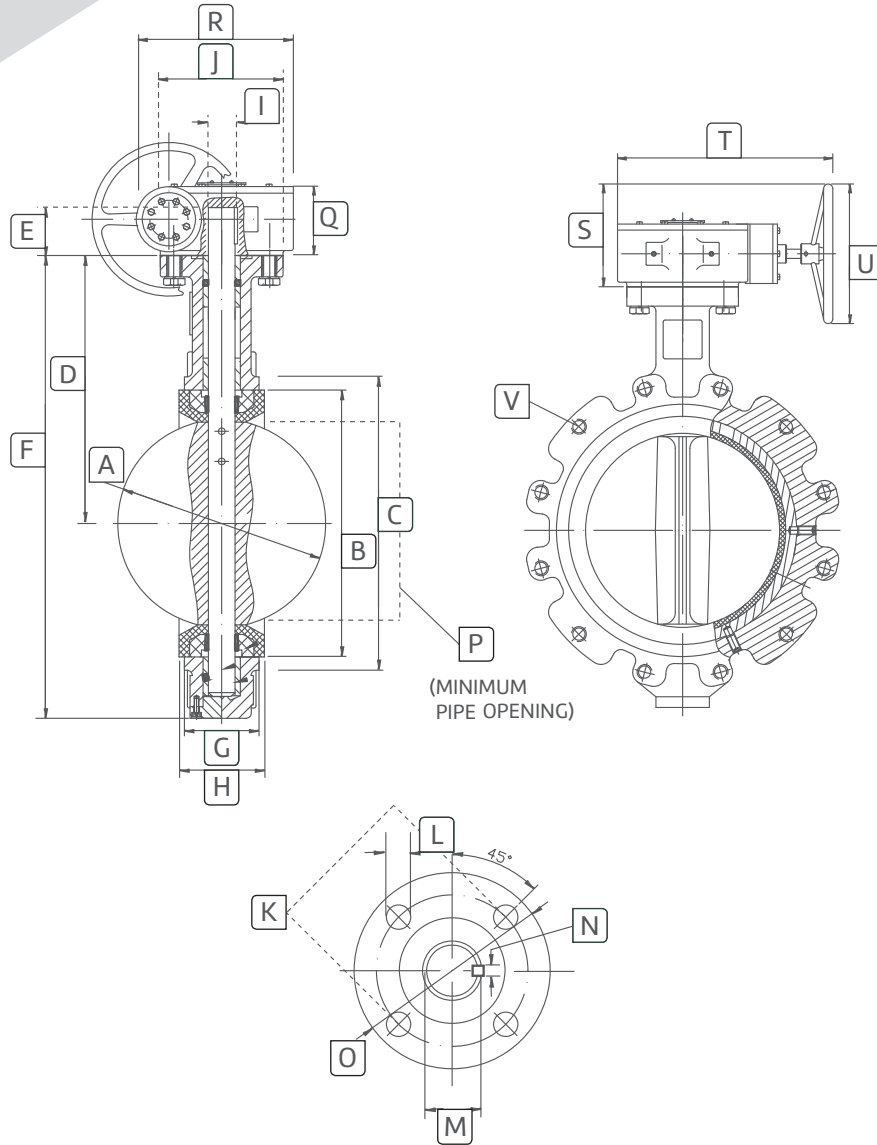

## Dimensions (Sizes 14" – 24")

Size	A	B	C	D	E	F	G	H	I	J	K	L	M	N	O	P	Q	R	S	T	U	V Lug	V Wafer
14	13.12	14.77	15.94	14.49	1.77	25.00	3.01	3.13	1.25	5.51	4.01	0.47	1.36	0.315	5.51	12.68	3.18	7.78	7.44	11.57	11.81	1-8 UNC	1.11
16	15.34	17.30	18.50	15.75	2.01	27.91	3.37	3.54	1.30	7.56	5.51	0.70	1.42	0.394	7.75	14.96	4.72	11.32	8.27	14.92	11.81	1-8 UNC	1.11
18	17.34	19.31	20.51	16.61	2.01	29.53	4.11	4.29	1.49	7.56	5.51	0.70	1.61	0.394	7.75	16.85	4.72	11.32	8.27	14.92	11.81	1-1/8-7 UNC	1.25
20	19.35	21.07	22.24	18.90	2.52	33.11	5.13	5.31	1.61	7.56	5.51	0.70	1.73	0.394	7.75	18.62	4.88	14.21	10.79	14.21	11.81	1-1/8-7 UNC	1.25
24	23.32	25.74	27.28	22.12	2.76	40.22	5.96	6.14	1.99	10.86	6.49	0.86	2.15	0.630	10.86	22.52	5.08	16.42	10.98	16.42	11.81	1-1/4-7 UNC	1.38

# Butterfly Valve Sharpe® Series 17

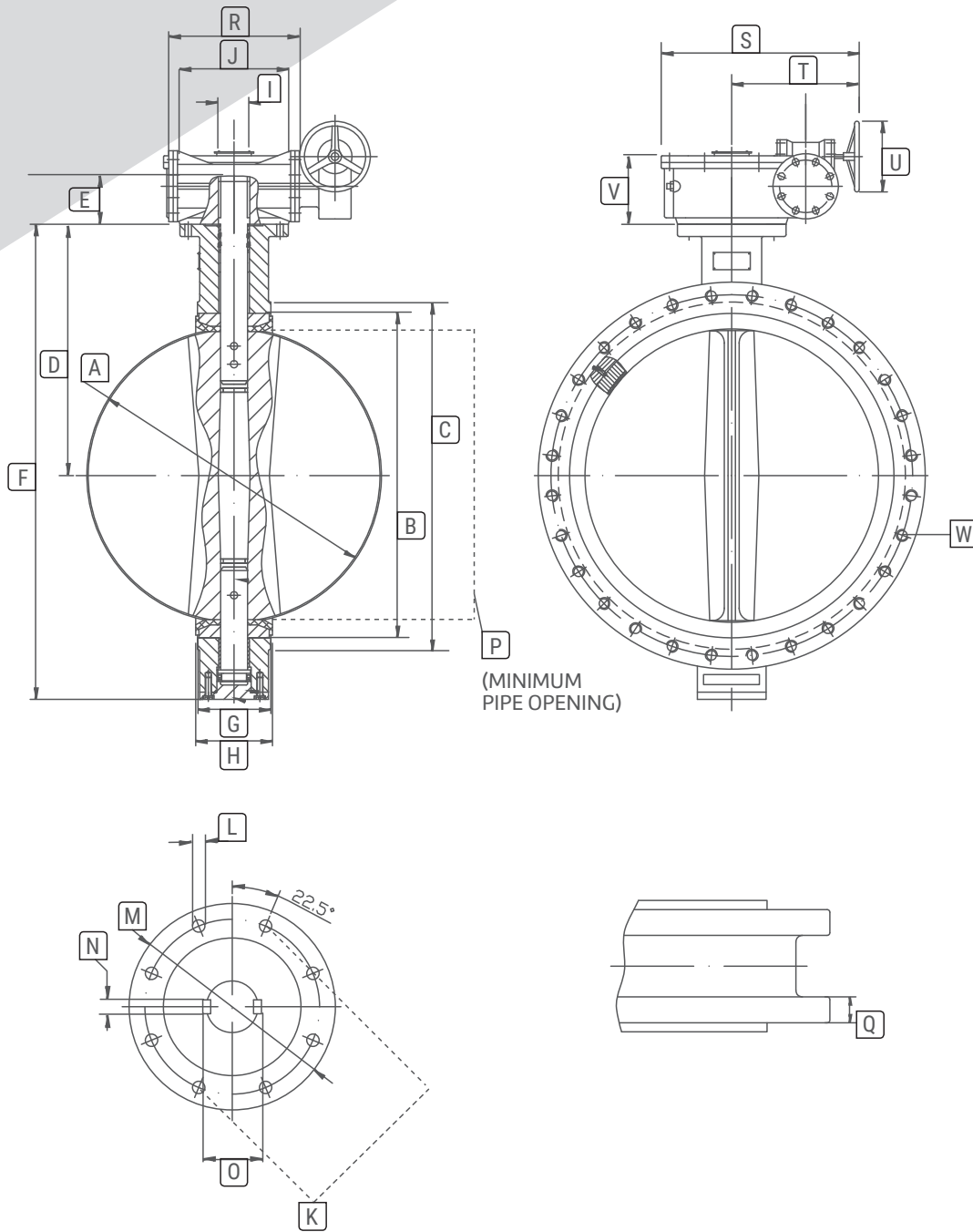

## Dimensions (Sizes 30" — 48")

Size	A	B	C	D	E	F	G	H	I	J	K	L	M	N	O	P	Q	R	S	T	U	V	W Lug
30	29.29	31.29	38.75	25.98	2.59	48.03	6.57	6.81	2.49	11.81	10	0.708	11.81	0.709	2.81	28.56	1.38	13.19	11.81	13.19	15.74	9.13	1-¼ - 7 UNC
36	34.05	37.28	46.00	28.34	4.64	54.17	7.99	8.30	2.95	11.81	10	0.708	11.81	0.787	3.31	33.09	1.65	14.05	13.94	14.05	17.71	7.51	1-½ - 6 UNC
42	40.55	44.27	53.00	33.78	5.90	64.37	9.88	10.27	3.74	11.81	11.73	0.866	13.77	0.984	4.13	39.33	1.81	17.72	19.68	17.72	17.71	9.92	1-½ - 6 UNC
48	45.66	49.77	59.50	37.04	5.90	71.05	10.86	11.26	4.13	13.78	11.73	0.866	13.77	1.102	4.61	44.35	1.97	22.95	28.50	22.95	19.68	11.69	1-½ - 6 UNC

# Butterfly Valve Sharpe® Series 17

## Parts & Materials

No.	Part Name	Materials
1	Body	Ductile Iron ASTM A536
2	Shaft	416 Stainless Steel ASTM A276
3	Disc	316 Stainless Steel ASTM A351 CF8M
4	Seat	EPDM Buna-N Viton*
5	Lower Bushing	PTFE
6	Middle Bushing	PTFE
7	Upper Bushing	PTFE
8	O-Ring	NBR
9	Retainer	Steel ASTM A283
10	Retainer Bolts	Steel ASTM A283
11**	Set Screws	Steel

**Note:**

\*Optional.

\*\*Lug Style Only.

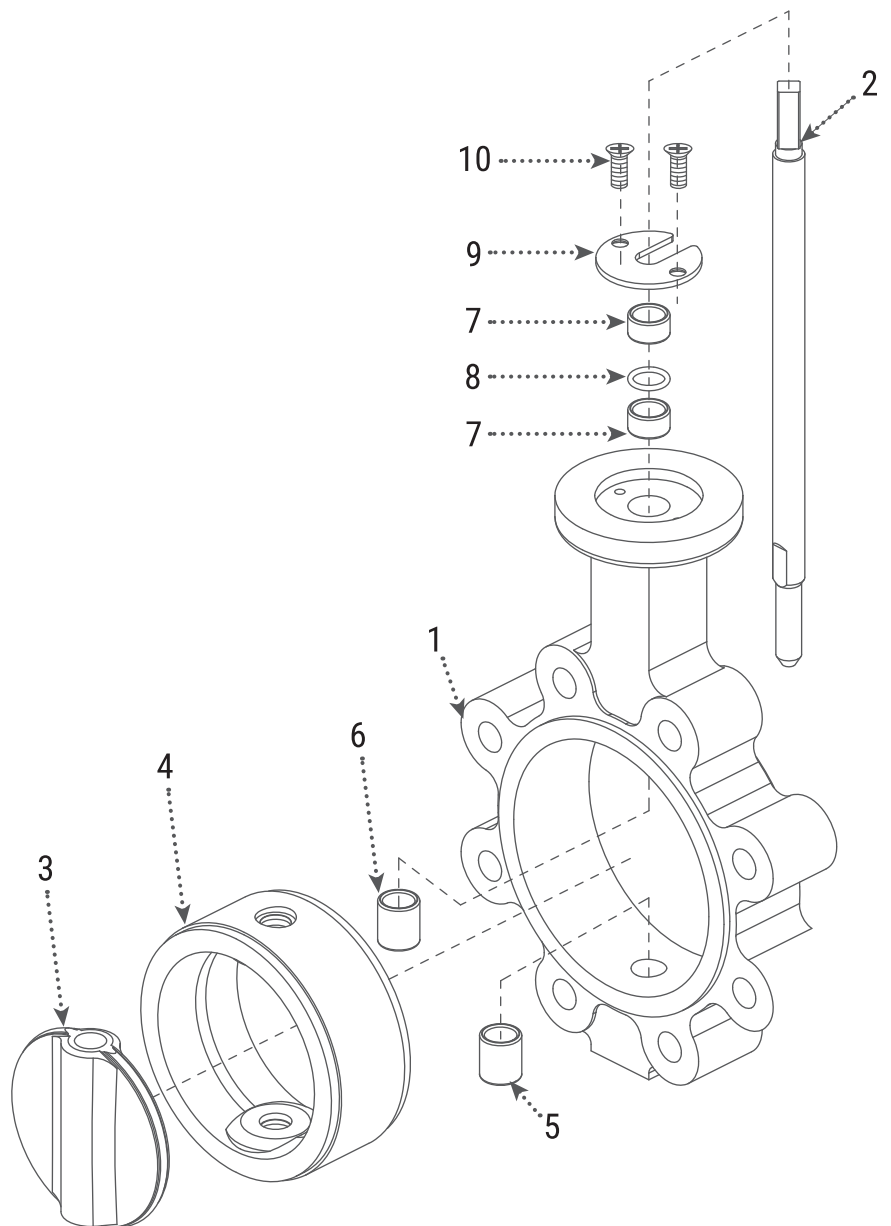

Technical Information

Size	Gear Op			C <sub>v</sub>									Torque			
	Output Lbs	Ratio	Gear Box	10°	20°	30°	40°	50°	60°	70°	80°	90°	50 psi	100 psi	150 psi	200 psi
2	1504	24:1	1 Stage	0.1	5	12	24	45	64	90	125	135	70	105	108	115
2-½	1504	24:1	1 Stage	0.2	8	20	37	65	98	144	204	220	100	150	136	152
3	1504	24:1	1 Stage	0.3	12	22	39	70	116	183	275	302	150	250	192	204
4	1504	24:1	1 Stage	0.5	17	36	78	139	230	364	546	600	230	260	328	352
5	1504	24:1	1 Stage	0.8	29	61	133	237	392	620	930	1022	350	530	512	548
6	1504	24:1	1 Stage	2	45	95	205	366	605	958	1437	1579	460	680	831	907
8	6195	30:1	1 Stage	3	89	188	408	727	1202	1903	2854	3136	740	1110	1527	1697
10	6195	30:1	1 Stage	4	151	320	694	1237	2047	3240	4859	5340	1330	1880	2530	2857
12	12620	50:1	1 Stage	5	234	495	1072	1911	3162	5005	7507	8250	2260	3150	3794	4338
14	12620	50:1	1 Stage	6	338	715	1549	2761	4568	7230	10844	11917	4070	5390	4870	5527
16	22126	80:1	1 Stage	8	464	983	2130	3797	6282	9942	14913	16388	5400	7120	6685	7484
18	22126	80:1	1 Stage	11	615	1302	2822	5028	8320	13168	19752	21705	6300	8750	8958	10010
20	22126	14:1	2 Stage	14	791	1674	3628	6465	10698	16931	25396	27908	8000	10800	11950	12667
24	35403	16:1	2 Stage	22	1222	2587	5605	9989	16528	26157	39236	43116	14600	20900	18680	20361
30	70806	16:1	2 Stage	35	1912	4050	8142	13152	20411	31226	47562	63328	-	-	33336	-
36	132761	16:1	2 Stage	60	3021	6063	11055	17449	26086	39731	60895	86375	-	-	46528	-
42	221268	16:1	2 Stage	93	4601	9235	16838	26575	39783	60592	92868	131725	-	-	79684	-
48	354030	20:1	2 Stage	121	5981	12001	21890	34548	51718	78770	120728	171243	-	-	111112	-

Size (In)	Pressure Rating (psi)	Temperature Rating (°F)					
		EPDM		Buna N		Viton®	
		Min	Max	Min	Max	Min	Max
2 - 12	200	-30	275	10	180	0	275
14, 16	150	-30	275	10	180	0	275
18 - 48	150	-30	225	10	180	0	275





### **About ASC Engineered Solutions**

ASC Engineered Solutions is defined by quality—in its products, services and support. With more than 1,400 employees, the company's portfolio of precision-engineered piping support, valves and connections provides products to more than 4,000 customers across industries, such as mechanical, industrial, fire protection, oil and gas, and commercial and residential construction. Its portfolio of leading brands includes ABZ Valve®, AFCON®, Anvil®, Anvil EPS, Anvil Services, Basic-PSA, Beck®, Catawissa, Cooplet®, FlexHead®, FPPI®, Golvlok®, J.B. Smith, Merit®, North Alabama Pipe, Quadrant®, SCI®, Sharpe®, SlideLOK®, SPF® and SprinkFLEX®. With headquarters in Commerce, CA, and Exeter, NH, ASC also has ISO 9001:2015 certified production facilities in PA, TN, IL, TX, AL, LA, KS, and RI.



[asc-es.com](http://asc-es.com)

Building connections that last™

FC-DS-SERIES-17-v01 20211103

