

DR. ROBERT · **UNKNOWN PLEASURES LTD. EDITION**

USER MANUAL & SAFETY INSTRUCTIONS

Thank you for purchasing the Dr. Robert *Unknown Pleasures* Ltd. Edition!
The most accurate replica of the legendary **Vox® UL 730 amplifier!**

aclam

www.aclamguitars.com

C/ Consell de Cent, 201 - local
08011 Barcelona. Spain
Llevinac S.L.
CIF: B64412406

Index

Overview	4
Features	6
Specs & Material Included	9
Powering Requirements	10
Operating Diagram	12
Controls	13
Advanced Internal Controls	18
Setting Examples	20
Setting Up on a Pedalboard	26
Trouble Shooting	29
Security Instructions	30
Warranty Terms	31

Overview

In 1966, **Vox®** released the **UL 730** amp along with an entire lineup of wattage options, ranging from 10 to 120w. back then, they were the leading edge in guitar amps featuring a mixed a solid-state preamp with a tube power amp section.

As Vox had a close relationship with **The Beatles**, just as they were released, some UL 700 series units were sent to the Fab Four for live use and recording. Eventually they ended up being extensively used on the **Revolver** album when it was recorded at EMI Studio.

Unfortunately, even though being endorsed by The Beatles, those amps did not achieve commercial success and most of them met their fate being returned to Vox for their disposal.

Only a small number of UL 730 got to escape the death row (around 20/30 units as some renown Vox connoisseurs state), attaining an almost unicorn-like status in the amp world.

Luckily, one of those **UL 730** ended in **Manchester** to be used on another of the most influential records of all time!

During the recording of **Joy Division's *Unknown Pleasures***, guitarist and co-founder Bernard Sumner tracked almost if not every cut through his **Vox UL 730** paired with an Altair PW-5 to tame its raw power and get saturation at reasonable volumes. Songs like 'Shadowplay' and 'She's Lost Control' are great examples of the unique tone he attained with his Gibson and Shergold guitars through the UL.

Seems like it was a happy accident, since that amp was not very popular in the late '70s, and he probably bought it for very little money. He really liked it though, since he used it for both live performances and studio sessions from the band's early days until today, where you can still see him using it live with **New Order!**

The **Dr. Robert *Unknown Pleasures* Ltd. Edition** is based on the Normal channel of our Vox® UL 730 S/N: 3042. We traced the original tag board circuits and measured

each component's value to make the closest replica of the amp's soul and character.

One of the keys of its tone is the **"Mids"** control which is one of the most interesting mid-range eq ever found on an amp. By turning it counterclockwise, a great amount of mid-frequencies will be subtracted creating a scooped sound. On the other hand, when it's turned clockwise it will bring out all the mids and the signal will build up in gain. By tailoring the **"Mids"** knob you can control both midrange and saturation.

As the solid-state preamp of the UL 730 doesn't create much distortion by itself we've coupled it with a **custom FET** saturation engine to mimic the attributes of the tube power amp section. Not happy with that, we've gone even further creating the **"Disorder!"** section, which adds saturation to your main sound and includes an independent volume control to allow you to have both a rhythmic and a solo tone.

Features

THE MOST ACCURATE REPLICA OF THE ORIGINAL UL 730 PREAMP:

Sometimes you can't trust the internet or an old schematic! We've found major discrepancies between the published schematic and the real thing, such as component types and values, so we can assure this is the closest you can get to the rarest Vox amp!

Following the preamp there's a custom FET based circuit emulating the saturation produced by the UL 730 EL84's tube power amp section.

DISORDER! FUNCTION:

Extra saturation function via a footswitch with an independent volume control. Hit it when you want the crowd to lose control!

CIRCUIT TAILORED FOR BOTH GUITAR AND BASS INSTRUMENTS:

Although based on the UL 730 preamp, the UL 400 series (designed for bass) shared almost the same circuitry. When doing tests using different instruments and amps

we noticed the Dr. Robert *Unknown Pleasures* Ltd. Edition sounded flawless with bass too!

By tuning the FET circuit a bit, we managed to make the Dr. Robert *Unknown Pleasures* Ltd. Edition suitable for both guitar and bass. No low-end drops resulting in a perfect preamp and distortion tool to plug directly to the desk or into an amp.

CUSTOM GRAPHICS TO PAY TRIBUTE TO JOY DIVISION'S DEBUT ALBUM:

To please Joy Division and New Order fans we've adapted Peter Saville's artwork idea to this limited edition.

HIGH END COMPONENTS:

We made an extra effort to put the finest and closest components to the original amp on the Dr. Robert *Unknown Pleasures* Ltd. Edition Carbon comp resistors, Nichicon Fine Gold and Wima caps, Alpha pots makes the Dr. Robert *Unknown Pleasures* Ltd. Edition a reliable pedal with a superb tone.

TRUE BYPASS RELAY SWITCHING:

We've designed an intelligent true bypass relay switching system which constantly monitors voltage supply (both battery or DC jack input) and switches itself to true bypass when it detects a drastic drop in voltage. This way you'll never get any signal interruption even if your power supply or battery fails. It also tells you when the battery is close to completely draining by making both the Disorder! and Bypass LED's (depending on your current setting) blink. So, you have at least 2-3 hours to replace the battery before the pedal goes into self-bypass.

SAME 3 BAND EQUALIZER VIA INTERNAL TREBLE AND BASS TRIM CONTROLS:

The "Mids" control is a unique feature to shape the particular sound of the Dr. Robert *Unknown Pleasures* Ltd. Edition pedal. But we didn't want to let you down in terms of tone shaping so the Bass and Treble controls found on the original VOX UL 730 are on the inside of the pedal!

SMART TRACK® FASTENING SYSTEM:

All our pedals use a custom enclosure designed to match perfectly our Smart Track® pedalboards. Using the side thumb screws, you'll be able to lock safely the stompbox into one of our pedalboards. It also was designed with the other pedalboard options in the market in mind. (see page 22).

Specs & Material included

DR. ROBERT REF:
AP0020-8

DIMENSIONS:
13,6 x 8,7 x 5,5cm (5.4" x 3.4" x 2.2") with knobs.

WEIGHT:
410g. (0.90 lbs).

BYPASS:
True Bypass

POWER REQUIREMENTS:
9V DC Center Negative 100mA minimum or a 9V battery

CURRENT DRAW:
≈40mA

DECLARATION OF CONFORMITY:
This product complies with the requirements of



MADE IN SPAIN

MATERIAL INCLUDED

1 x Dr. Robert *Unknown Pleasures* Ltd. Edition pedal
1 x Anti-sliding rubber pad
1 x Velcro® pad
1 x Carrying bag

Power requirements

9V BATTERY

To operate the Dr. Robert *Unknown Pleasures* Ltd. Edition with a 9V battery you'll have to follow the next steps:

- 1 Loosen the side thumb screws and disassemble the Smart Track[®] system of both sides of the pedal.

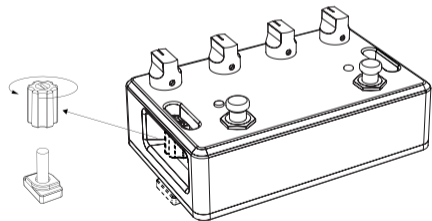

- 2 Remove the screws of the baseplate to access the inside of the pedal.

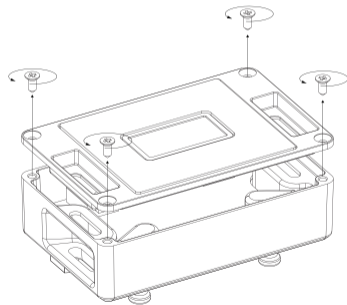

- 3 Put the 9V battery in the position showed in the diagram. Make sure to use a good quality alkaline battery to ensure the longest time of operation.

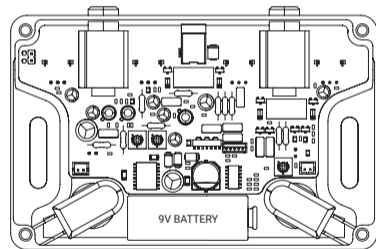

- 4 Tight back the lid with the 4 screws and reassembly the Smart Track[®] system.



CAUTION:

If used improperly, batteries may explode or leak and cause damage or injury.

- The use of an incorrect type of battery can void the safeguard mechanisms of the device (for example, in the case of some lithium battery types)
- Batteries must never be recharged, heated, taken apart, or thrown into fire or water.
- Do not expose the unit to extremely high temperatures, direct sunlight or other devices that radiate heat, as it may lead to an explosion or leakage of flammable liquid or gas.

POWER SUPPLY

This unit can be powered with a 9VDC negative tip power supply with the standard Boss type 2.1mm connector.

Current supply should be a minimum of 100 mA just to leave a safety margin for the DC adapter.

Make sure you use a good quality power supply and avoid using generic SMPS type adapter which can induce high pitched noise to the audio.

Operating Diagram

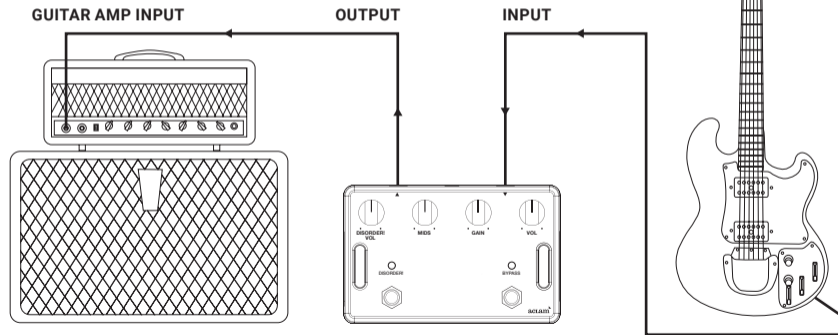

Controls

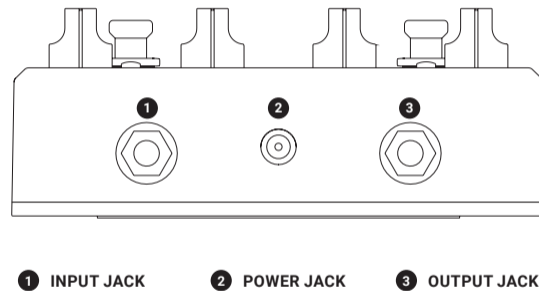

- 4 **BYPASS SWITCH:** Engages the unit allowing the signal to flow through the *Unknown Pleasures Ltd. Edition* circuit. It also lights up the LED above it.
- 5 **VOL:** Controls the overall volume of the Dr. Robert *Unknown Pleasures Ltd. Edition* when you're not using the Disorder! section.
- 6 **GAIN:** This control is placed in the same position of the circuit as the original UL 730's volume control. Since none of the Vox® UL series had a master volume control the user had to turn it all the way up to bring the amp into saturation, and believe us, this thing is loud. To solve that we put the Vol control at the end of the FET section so now, the volume control on the original amp turns into a gain knob on the Dr. Robert *Unknown Pleasures Ltd. Edition*

At lower settings the Gain knob will produce a clean tone, but as you approach the 12'o-clock mark the FET section will start entering the saturation region.

Have in mind that due to Dr. Robert *Unknown Pleasures Ltd. Edition* great dynamics, different types of guitars and pickups will affect the clean range of the Gain knob.

- 7 **MIDS:** This is the most critical knob to tailor your sound. Unlike most equalizer circuits (which get placed after or before the volume control) Vox® separated the "Mids" control from the rest of the tone stack in the UL 730. In this preamp the signal gets amplified first, followed by the "Mids" control before the volume pot. After this, Vox® placed a special gain stage coupled with the Bass and Treble controls. Thus, you can control the midrange without interacting with the rest of the eq, as traditional tone stacks do. By turning it counterclockwise, it will subtract a great amount of mid-range, creating a really interesting scooped sound. Turning it clockwise will bring mid frequencies and the overall gain builds up hitting harder the EL84 tubes, creating saturation.

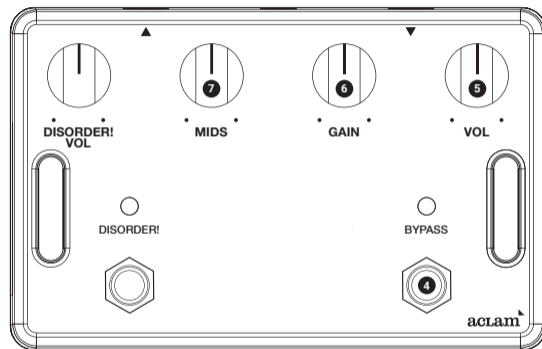

Just like the real amp does, Dr. Robert *Unknown Pleasures Ltd. Edition* "Mids" control has the same behavior thanks to the FET section specially tuned to mimic the power amp saturation on the UL 730. So, keep in mind, the "Mids" knob will have a great effect on the overall saturation of the unit.

THE DISORDER! SECTION

The Disorder! section was conceived during the design process of the Dr. Robert to make it more versatile in live scenarios. Every now and then, you need an extra push in terms of gain, to play solo parts or for songs you want people to shake their waist at.

Taking Joy Division's "Shadowplay" cut for example, there's a lead part, clearly saturated and the main rhythmic part in a cleaner tone. With the Dr. Robert *Unknown Pleasures* Ltd. Edition you could play both tones using the Disorder! section for the lead parts.

The Disorder! extra saturation will always be determined by the "Gain" and "Mids" knob settings, meaning that the heavier your main setting is, the grittier this section will build up from. Paired with the extra gain circuit there's an independent volume control labelled "Disorder! Vol" to allow you a better control of this section. Easy and simple :)

- 8 DISORDER! SWITCH:** Activates the Disorder! Section. It also lights up the LED above it.

(Note that the Disorder! function works only when the Dr. Robert *Unknown Pleasures* Ltd. Edition bypass switch is activated. This function is not an independent overdrive but an extra tone of Dr. Robert *Unknown Pleasures* Ltd. Edition main circuit).

- 9 DISORDER! VOL:** Independent volume control for the Disorder! section.

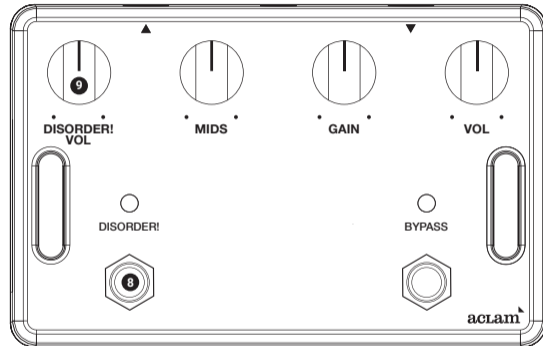

Advanced Internal Controls

The original UL 730 had a 3 band eq, but since the Middle control is the one that helps to tailor the tone better we decided to put the Bass and Treble controls inside the pedal. Just to make the user interface cleaner and easier to operate.

HOW TO ACCESS THE INTERNAL CONTROLS:

Just follow the same steps described on the 9V battery replacement instructions. To adjust the internal controls, grab a small flat screwdriver :)

1 BASS:

Sets the amount of low frequency content reaching the FET section. The Treble and Bass controls work together in a tone-stacked manner, so they are a bit interactive.

Both controls are factory set at 12 o'clock.

2 TREBLE:

Controls the amount of high frequency content of the signal before reaching the FET section. Setting this knob will have an effect over the overall gain.

3 DISORDER! GAIN TRIM

We have included a Gain trim for the Disorder! section. This will allow you to lower the saturation and make it a little bit less aggressive. At high gain settings it's less effective but a lower gain it will make the Disorder! sound a bit gentler. Try it and experiment!

Factory setting is fully clockwise (max gain)

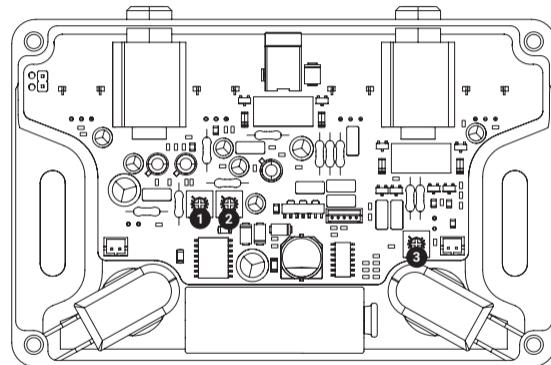

1 BASS

2 TREBLE

3 DISORDER! GAIN TRIM

Setting Examples

To show you the immense potential of the Dr. Robert *Unknown Pleasures* Ltd. Edition, we recommend you trying the following setting examples. These examples do not show specific positions for the VOL and Disorder! Vol knobs as they will depend on the output of the guitar you use. **The Dr. Robert *Unknown Pleasures* Ltd. Edition pedal is pretty loud at mid to high gain settings so we recommend you to start with both volume knobs at 9 o'clock and adjust them to match unity gain of the unit bypassed.** This way you can make sure you're not overloading the amp's preamp and all the saturation comes from the Dr. Robert *Unknown Pleasures* Ltd. Edition.



These examples were fine-tuned with different guitars (mentioned on each diagram) and a Doctor Z Maz 18 amp.

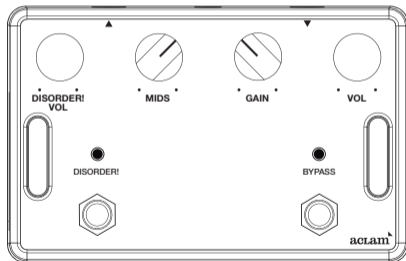

DISORDER
Gibson SG

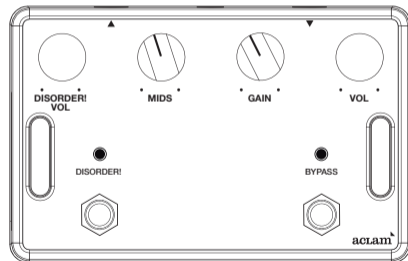

NEW DAWN FADES
Gibson SG

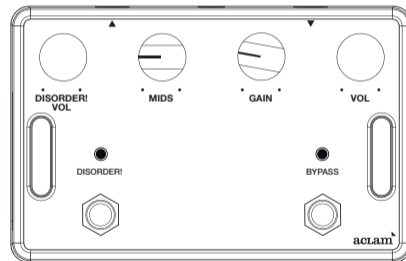

SHE'S LOST CONTROL
Gibson SG

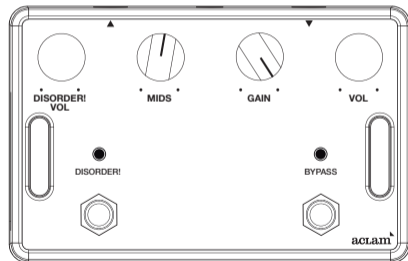

INTERZONE
Gibson SG

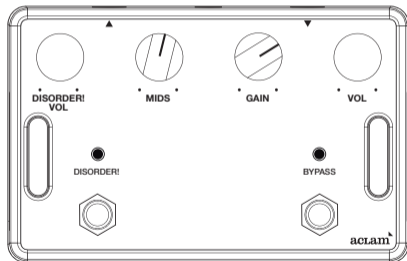

JOY DIVISION - SHADOW PLAY (SOLO)
Gibson SG

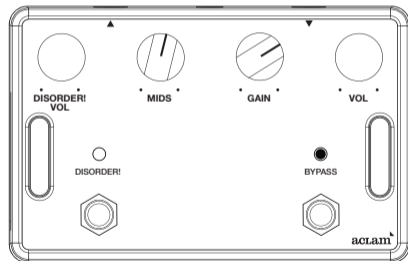

JOY DIVISION - SHADOW PLAY (RYTHM)
Gibson SG

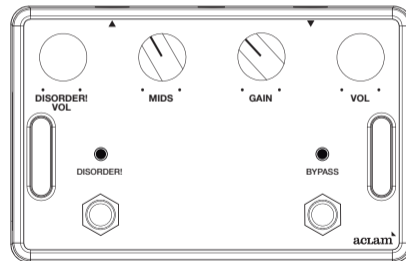

PAPERBACK WRITER (LEAD GUITAR)
Epiphone Casino & Gretsch 7120

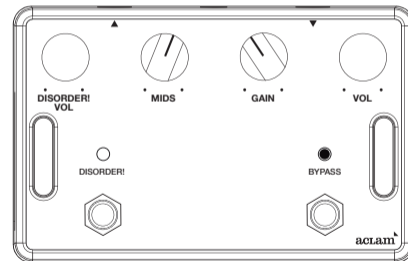

DR. ROBERT
Epiphone Casino



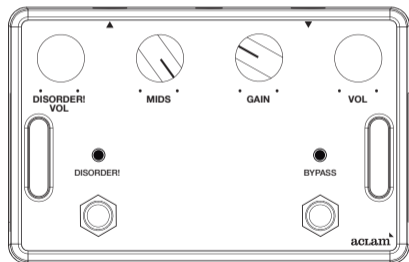

TAXMAN
Fender Stratocaster

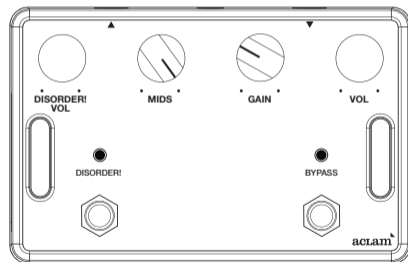

TAXMAN (SOLO)
Fender Stratocaster

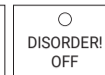

Setting up on a pedalboard

All our effect pedals use a custom light aluminum enclosure specially designed to fit our Smart Track® pedalboards. We incorporated a proprietary locking system which allows the user to fasten the pedal without the need of using the typical hook and loop method. This custom fastening system follows the same philosophy behind the Smart Track® fasteners but integrated in the enclosure reducing the space occupied by each pedal.

That translates into more pedal density for the same space, and who doesn't want that?

We strongly recommend you to take a look at our line of pedalboards, which are the best complement to our pedals!

HOW TO MOUNT IT ON A SMART TRACK® PEDALBOARD:

- 1 Add the anti-sliding rubber pad at the bottom of your pedal, specially shaped for this unit.
⚠ Surface must be clean and dry before applying adhesive pad.

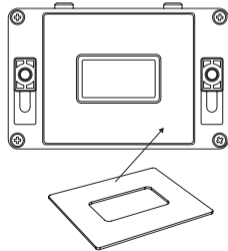

- 2 Loosen the 2 thumb screws to unlock the bottom pieces out of the pedal.
- 3 Place the pedal, inserting the bottom pieces inside the grooves.

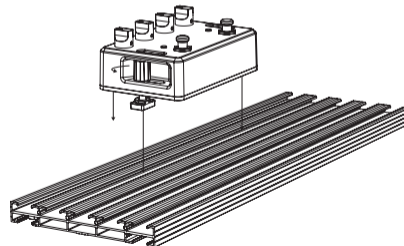

- 4 Move the pedal to its final position.

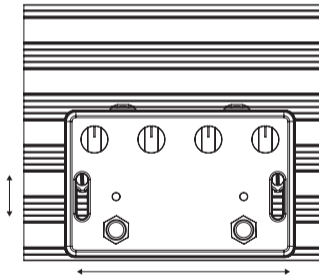

- 5 Tighten the two thumb screws with your hands or with a screwdriver.

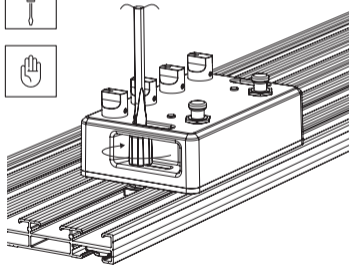

USING OTHER PEDALBOARDS:

Hook and Loop: Take the included super strong Velcro® pad and stick it on the base plate. Again, make sure the base is clean of dirt and dust.

Pre-drilled pedalboard: Fix it with a bolt and a nut you could find at any hardware store or instead of passing the zip tie over the pedal you can take advantage of the Smart Track® enclosure and put the zip ties over the holes.

DIY woodboard: You can screw the pedal directly with wood bolts through the enclosure side holes.

No board: If you use the pedals standalone make sure you place the included anti-sliding rubber pad on the baseplate.

Trouble Shooting

SIGNAL PASSES THROUGH IN BYPASS BUT NOT WHEN ENGAGED:

Make sure you've connected the input and output jacks correctly.

PEDAL DOES NOT WORK WITH THE POWER SUPPLY:

Take a look at your power supply output voltage and polarity. Make sure it's 9V DC negative tip with a minimum output of 100 mA.

PEDAL WON'T ENGAGE WITH BOTH THE POWER SUPPLY AND BATTERY:

Check there's a plug inserted into the Input Jack.

PEDAL SOUNDS DISTORTED AT REALLY LOW SETTINGS:

- If you're running on batteries replace it with a new one or check the voltage with a multimeter.

- The Dr. Robert is a really dynamic pedal the same way the original amp is. Different types of guitars and pickups will make it saturate in different regions of the knobs. That is a totally correct response from the unit.

- Make sure there's not any pedal before the Dr. Robert increasing too much the guitar's signal output, like boosters, preamps compressors and other overdrive pedals.

THE LEDS ARE BLINKING:

If you're powering your Dr. Robert with a battery replace it with a fresh one. See page 7 for more info.

Security Instructions

- Read these instructions carefully.
- Keep them for future reference.
- Heed all warnings.
- Aclam Guitars shall not be held liable for any damage to persons or property caused by incorrect operation or installation.
- Use the product in accordance with the assembly instructions. Do not modify or operate the product incorrectly.
- Incorrect installation could result in serious damage to persons and property.

- Open the package and check that the assembly instructions and all the parts of the product are there. Check that none of the parts are defective.
- Keep out of reach of children. This product contains small parts that represent a choking hazard if swallowed.
- If you do not understand these safety instructions, or if you have any queries regarding the safety of the installation, please contact Aclam Guitars: support@aclam.cat
- If you wish to contact Customer Services at Aclam Guitars, please write to guitars@aclam.cat

Warranty Terms

This product is covered by a two-year warranty from the purchase date, under the conditions and supporting evidence regulated by current Spanish Legislation. The product warranty will only be applicable by presenting the proof of purchase (which is the invoice or the receipt) and serial number.

A product is covered under warranty if it presents lack of conformity because it does not correspond to the specified product characteristics, is defective which prevents its normal use according to its purpose, or does not function as described. The purchaser has the right to have the article repaired or replaced (either the product or the faulty component, at the discretion of the manufacturer).

The warranty is not transferable and won't cover the following issues:

- Attempts of modifications or repairs by an unauthorized service center.

- Unsuitable use.
- Incorrect storage.
- Explosions or burns caused by incorrect power supplies.
- Other causes not attributable to the manufacturer.

To make a claim, the purchaser must return the product to the store where it was purchased within one month from discovering the fault, and report the nature of the problem, the time and the circumstances under which it occurred.

If the product was purchased through our website, the purchaser must refer to www.aclamguitars.com and complete a RMA (Return to Manufacturer Authorization) form before returning the unit.

We strongly recommend looking at the "Troubleshooting" section of the manual before panicking!!

aclam

www.aclamguitars.com