

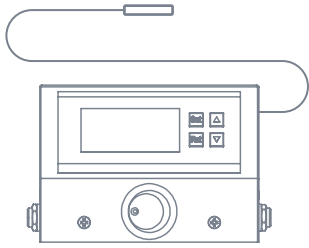

ENGINEERING BETTER BEER

FTSs | Jacketed Unitank

FTSs | JACKETED UNITANK



FTSs Controller
w/ Thermoprobe

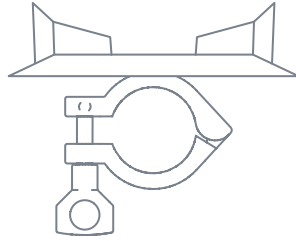

FTSs Controller Mounting Bracket



Pump Inlet Cover

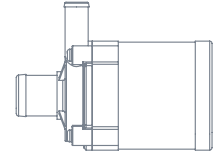

Pro Grade Submersible Pump

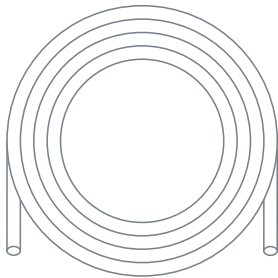

Silicone Tubing

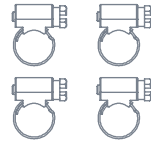

Hose Clamps



Hose Barbs
3/8" to 1/2" MPT

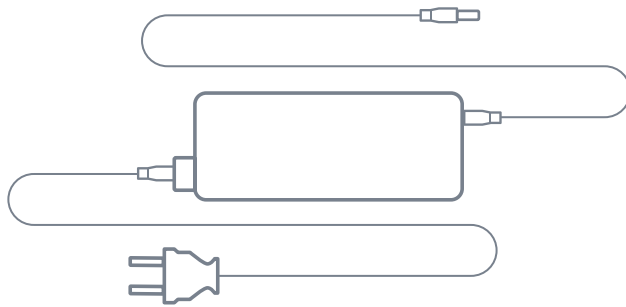

FTSs Power Supply



FTSs Pump Harness Extension



Check Valve Assembly

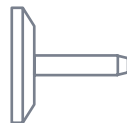

1.5" TC Sleeved Thermowell Adapter



Silicone Thermowell Cover

SYSTEM OVERVIEW

The basic principle of the Fermentation Temperature Stabilization System (**FTSs**) is to pump chilled glycol through the jacket when the temperature of your wort is greater than the controller set-point.

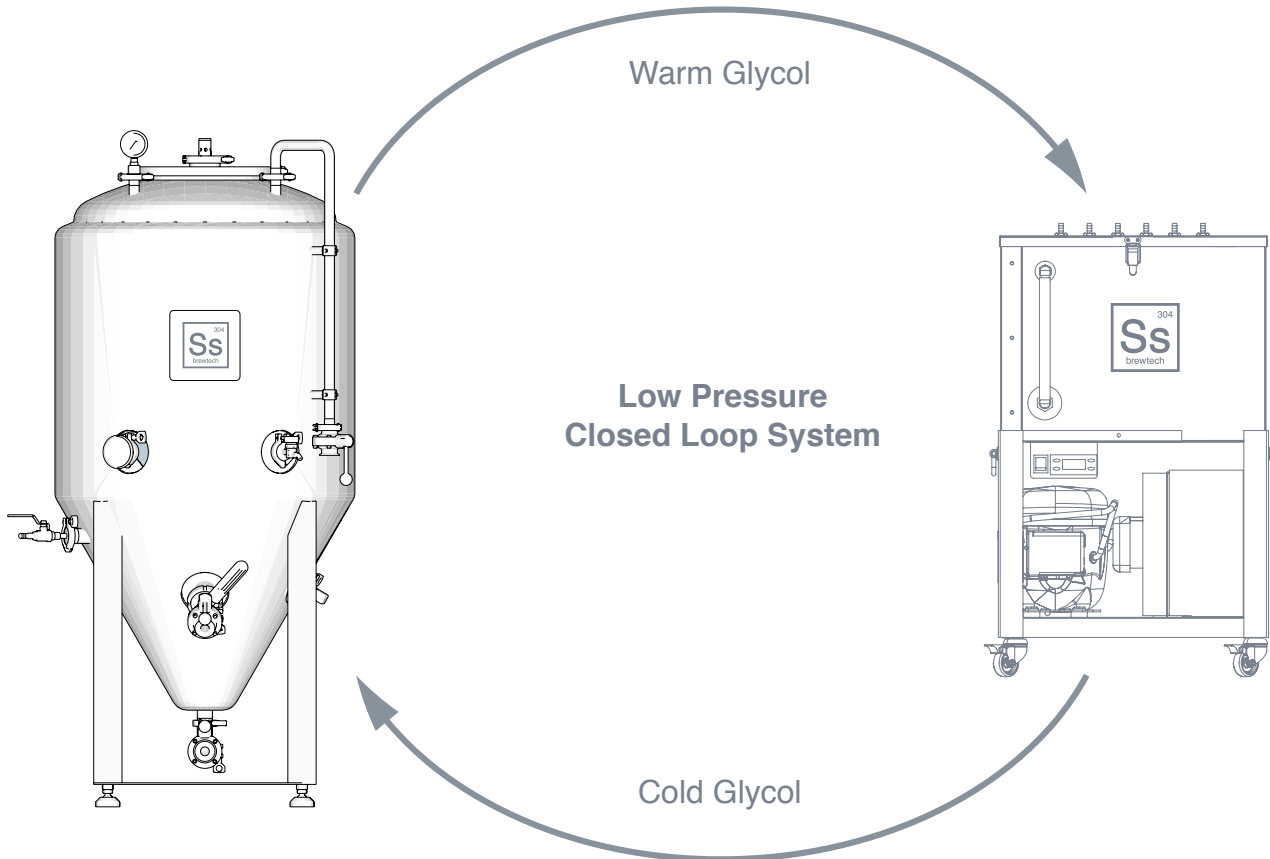

The FTSs is intended to be a low pressure closed loop system. Glycol pumped from the glycol chiller to the fermenter is then returned to the glycol chiller to be used again.

If your setup requires more distance from the fermenter to the glycol chiller, you can purchase common silicone tubing at most hardware stores. The pump is capable of lifting the glycol up to 10 feet. Pumping beyond 10 feet will negatively affect efficiency.

NOTES ON EFFICIENCY

Efficiency of your system depends on many variables. Ideally, you would have the fermenter in an area where the temperatures are relatively moderate. You should avoid using your FTSs to bring the wort from a high temperature to a pitching temperature.

INSTALLING THE FTSS_s CONTROLLER MOUNTING BRACKET

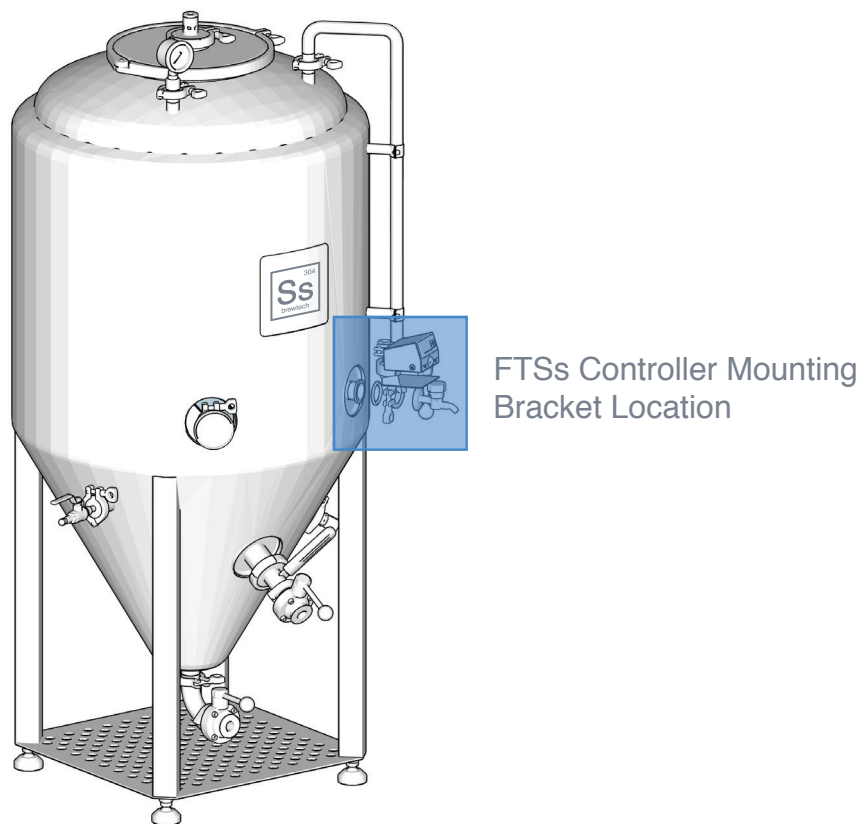
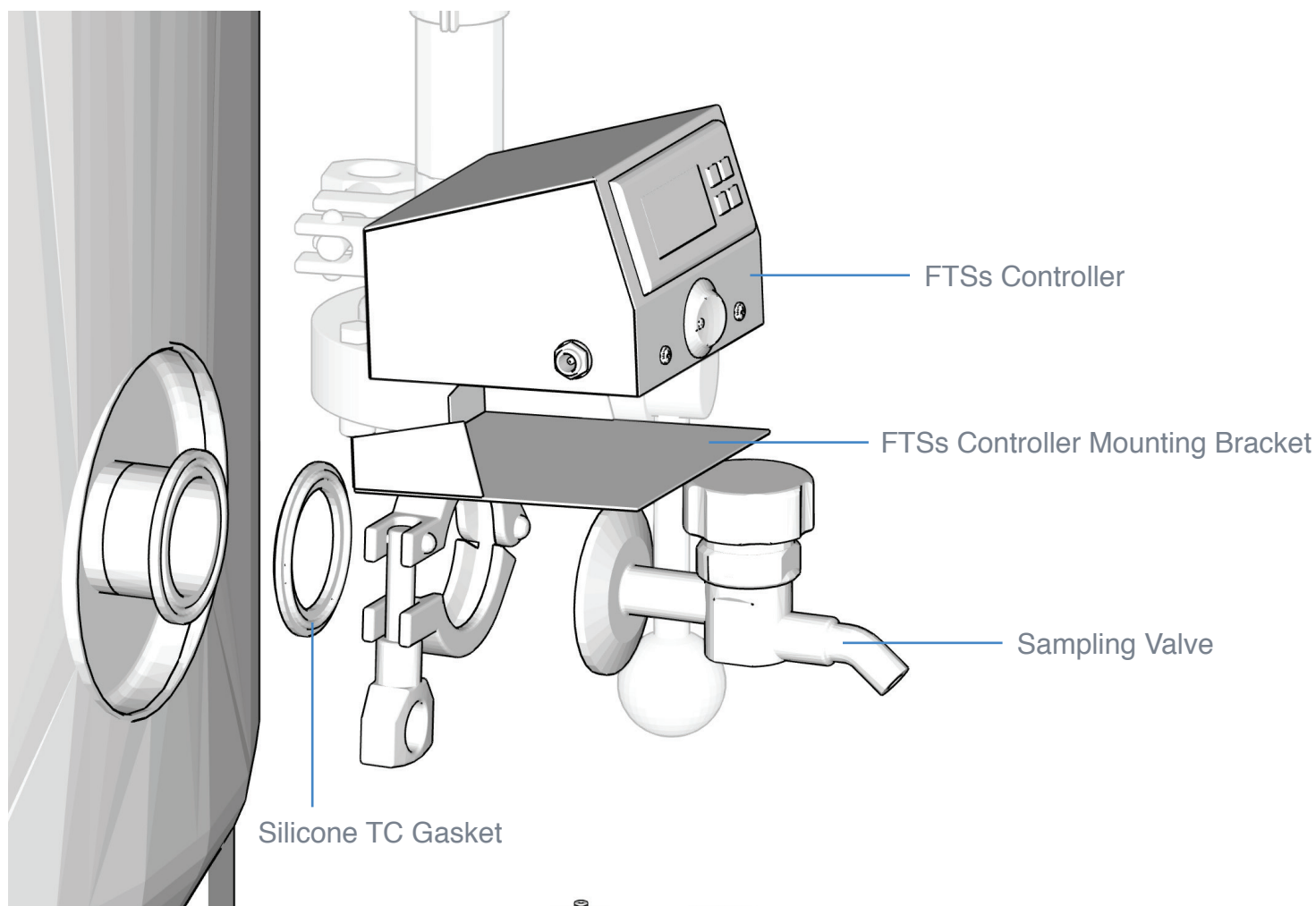

INSTALLING THE 1.5" TC SLEEVED THERMOWELL ADAPTER

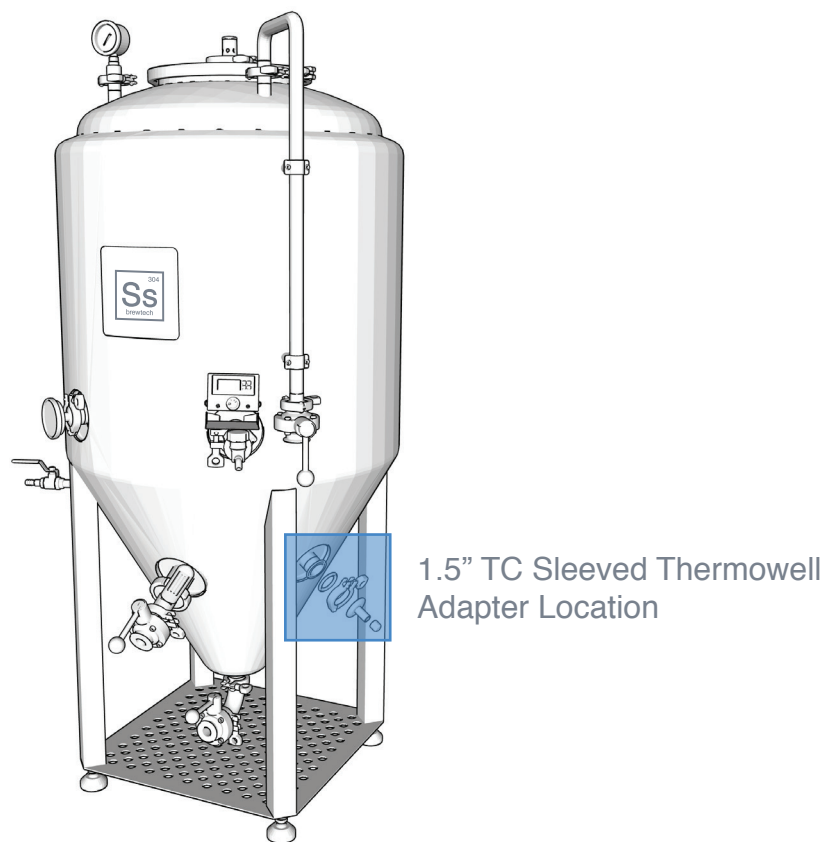
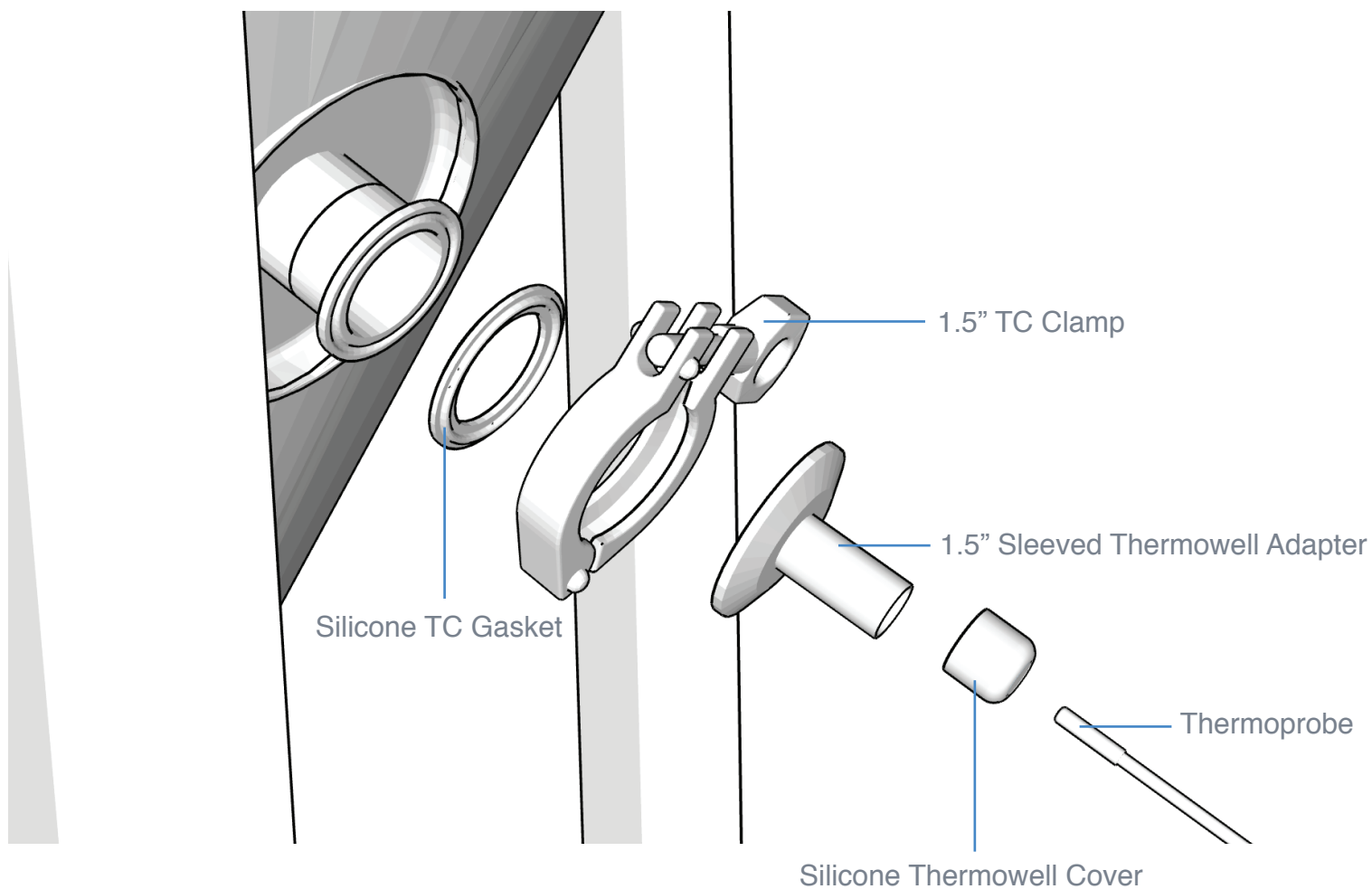

FTSs PUMP SETUP

Place the silicone pump inlet cover over the intake port of the submersible pump.

Connect a section of silicone tubing to the pump outlet and secure with hose clamp.

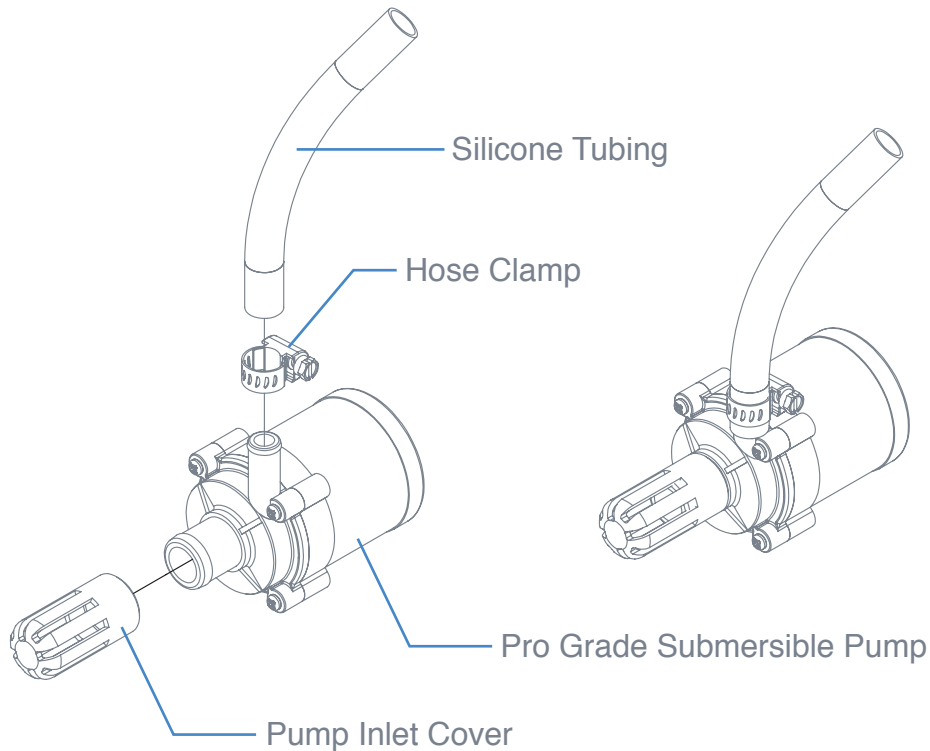

FTSs CONTROLLER CONNECTIONS

Place the digital controller's temperature sensor into the thermowell. Be sure the sensor goes all of the way into the bottom of the thermowell.

Plug in the pump power cable and system power supply as marked on the digital controller.

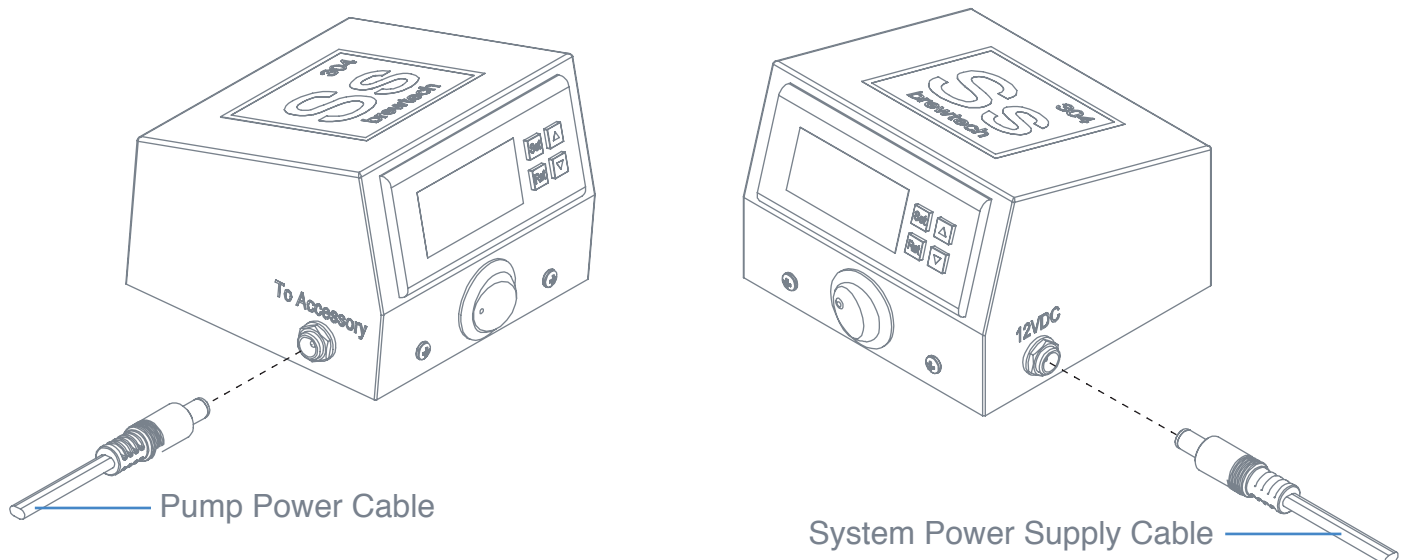

GLYCOL CHILLER CONNECTIONS

Divide a piece of silicone tubing into two equal lengths. Connect one end of one tube to the submersible pump outlet and secure it with a hose clamp. The pump outlet is the small pipe connection on the top side of the pump. Connect the other end of the same piece of tubing to the hose barb on the check valve (Fig A). Take the other half of silicone tubing and connect one end to the hose barb on the upper fitting of Unitank (Fig B) and run the other of the tubing back to any hose barb on the glycol chiller not occupied with a pump.

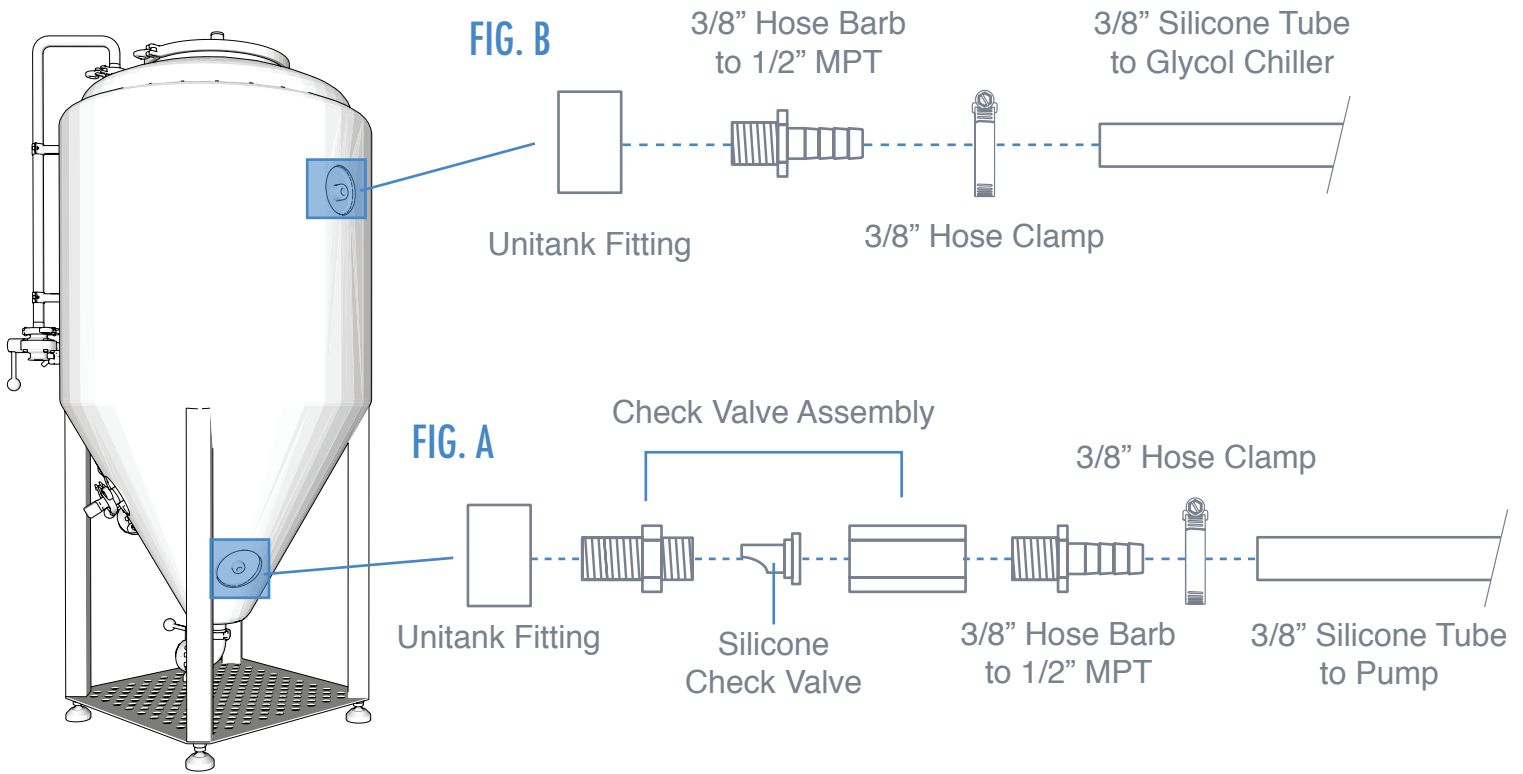

*Note: Be sure to use Teflon tape on any threaded fittings

INSTALLING THE FTS_s SYSTEM TO GLYCOL CHILLER



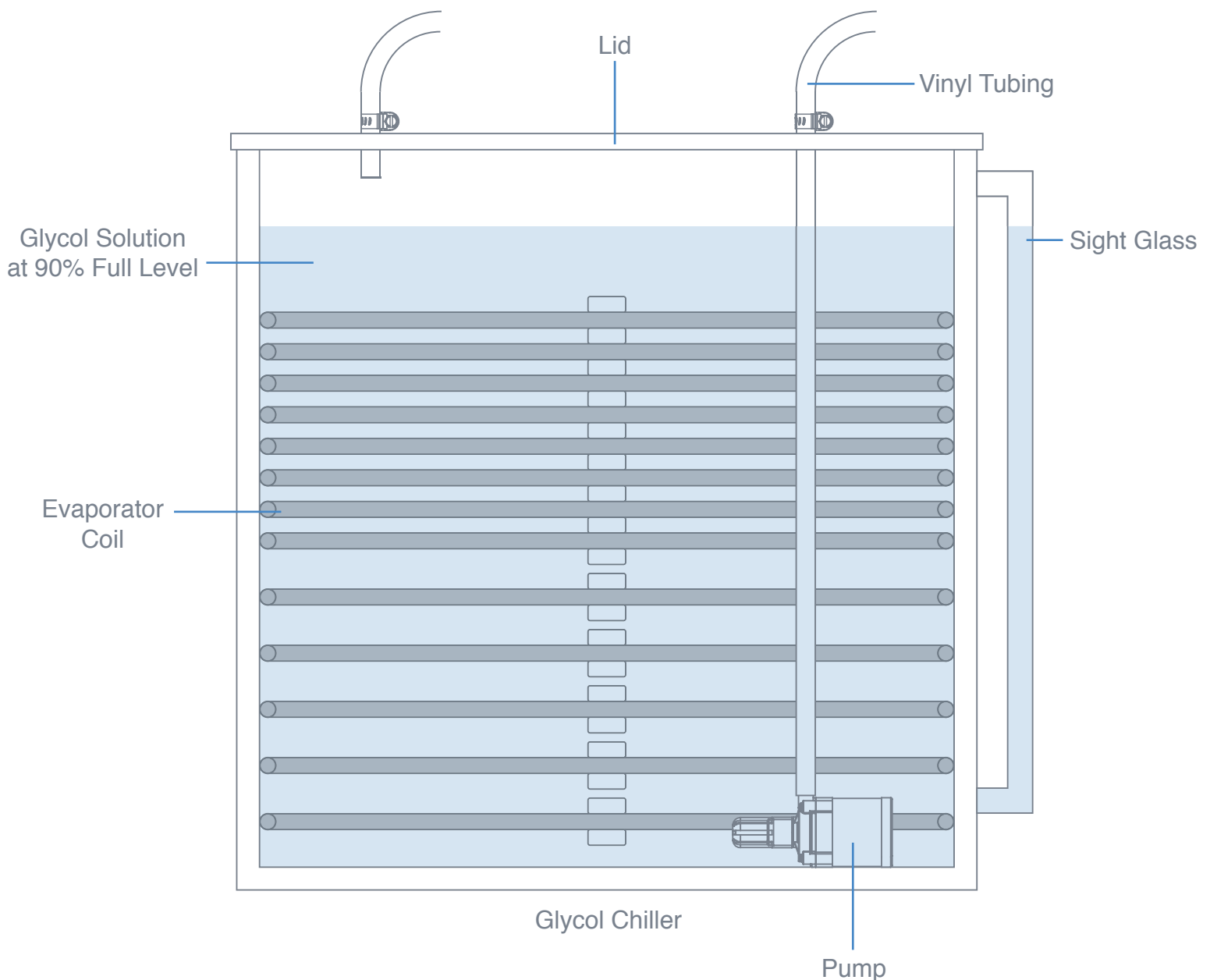

1. Ensure you have allowed the chiller to settle in an upright position for at least 24 hours, begin by removing the reservoir lid and connecting the FTS_s pumps to barbs on the underside. Size the tubing that runs from the submersed pump to the lid barb so that the pump rests at or near the bottom of the reservoir. Take care to mark the barbs where the pumps are attached. Next, pour a well blended solution of 65% distilled water / 35% glycol into the reservoir, bringing the reservoir up to 75% capacity.
2. Next submerge the pump(s) in the glycol solution, and top off the reservoir to about the 90% full level, making sure the evaporator coil is sufficiently submerged. This will allow glycol to flow through each fermenter's jacket without risking the chance of flowing back to the reservoir and overflowing the reservoir. Use the reservoir's sight glass as an indicator for glycol level.



OPERATING INSTRUCTIONS (CONTINUED)

3. Reinstall the reservoir lid, and route the pump's lead wire(s) through the notch when the evaporator coil enters the reservoir. Next, extend a length of 3/8" tubing from the pump outlet barbs on the reservoir lid, taking note to install the tubing to the same hose barb where the pump is installed. Run that length of tubing to the hose barb connected to the check valve on the lower tank fitting.
4. Finally, run a second length of tubing from the upper tank fitting with hose barb to any glycol chiller barb that is not occupied by a pump. We recommend using hose/tubing/pipe insulation wherever possible to help the chiller operate more efficiently.
5. Lastly, make all of your final FTSs connections, using hose clamps wherever possible, and turn on the controller to check for leaks. Let the FTSs pumps run for 5-10 minutes to assist in blending the glycol solution. If no leaks are apparent, go ahead and power up the glycol chiller using the red rocker switch to the left of the temperature controller.
6. To adjust the glycol reservoir's set temperature:
 - Press "SET" button.
 - Use the Up/Down buttons and navigate menus until "SET" menu appears. Press "SET" button.
 - Use the Up/Down buttons to adjust temperature to a range between 28°F - 32°F. Press "SET" button to set temperature.
7. To change controller between Celsius and Fahrenheit:
 - Hold "SET" button for 5 seconds.
 - Use the Up/Down buttons and navigate to "PA2" menu and press "SET" button.
 - Use the Up/Down buttons and set to "15" and press "SET" button.
 - Use the Up/Down buttons and navigate to "Di5" menu and press "SET" button.
 - Use the Up/Down buttons and navigate to "Dro" menu and press "SET" button.
 - 0 = Celsius / 1 = Fahrenheit. Press "SET" button.
 - Press the "STAND BY" multiple times to back out of all the menus.
8. Keep in mind that your individual results, and maximum delta between reservoir temperatures and vessel temperatures may vary. Factors such as ambient temperatures, efficiency losses, and tubing length can contribute to these effects.



KEYS	
 UP Press and release to: <ul style="list-style-type: none">- Scroll through menu items- Increase values Press and hold for at least 5 secs <ul style="list-style-type: none">- Activates Manual Defrost function	 DOWN Press and release to: <ul style="list-style-type: none">- Scroll through menu items- Decreases values
 STAND-BY (ESC) Press and release to: <ul style="list-style-type: none">- Go back to previous menu level- Confirm parameter value Press and hold for at least 5 secs <ul style="list-style-type: none">- Activates Stand-by (OFF) function (from outside menus)	 SET (ENTER) Press and release to: <ul style="list-style-type: none">- Displays any alarms (if active)- Open Machine Status menu Press and hold for at least 5 secs to: <ul style="list-style-type: none">- Open programming menu- Confirm commands

FERMENTING - SETTING THE FTSS TO OPERATE

1. Toggle the main power switch “On”. The digits of the display will illuminate.
2. Momentarily press (less than a second) the “Set” button.
3. While the “Set Light” is illuminated, press the “Up/Down” buttons to select the desired temperature setting.
4. Once you have the desired temperature selected, momentarily press the “Set” button again. This will then set the controller to attain the desired temperature.
5. When the system calls for cooling, it will illuminate the “Working Light” and the pump will start to cycle chilled water through the immersion coil.
6. Sit back, have a beer and enjoy the magic of thermodynamics at work.
7. Depending on the ambient temperature, it’s a good idea to check on your chilled water source and ice once or twice a day.

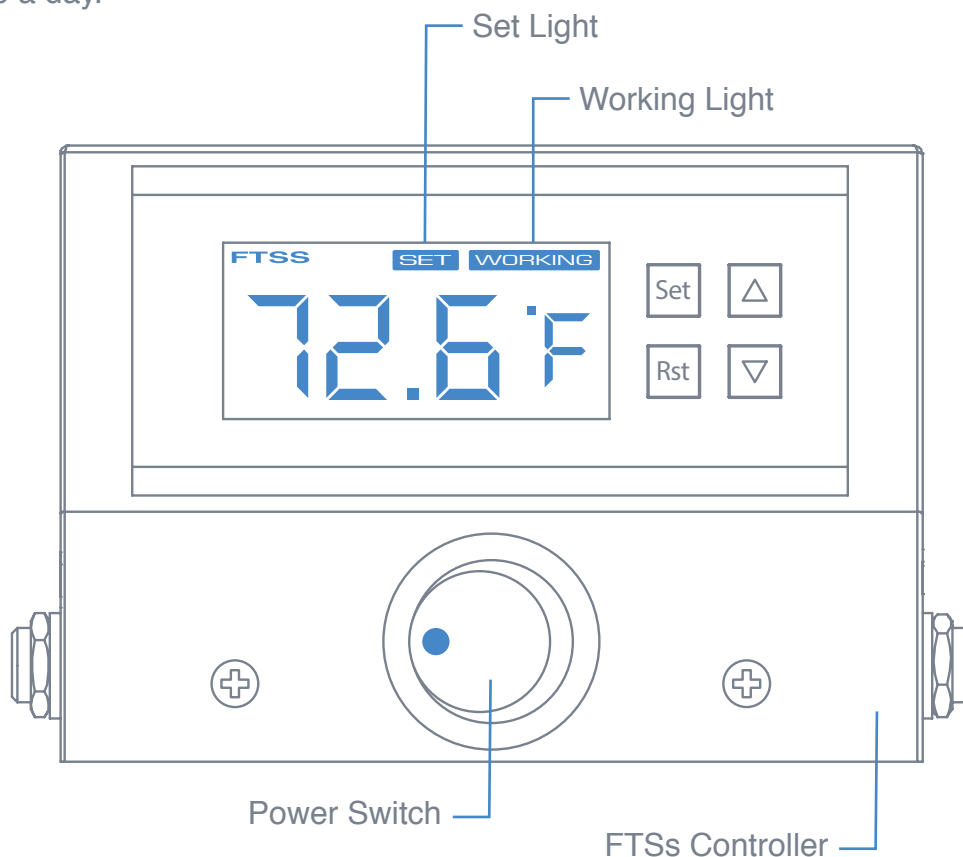

You can also reset the controller to see if a setting is not allowing it to kick on.

1. Press and hold the “Set” button and the “UP” button key simultaneously for 3 seconds. This will get you to the advanced settings menu.
2. Then press and hold the “Rst” key. The screen will restart and all settings will be reset back to the factory default settings.

ADVANCED CONTROLLER SETTINGS

There are a number of advanced settings that can be changed on the controller. In general, you will not need to make any changes. These settings are accessed by holding the “**Set**” button for more than 3 seconds.

SELECTING BETWEEN CELSIUS OR FAHRENHEIT

Press “**Set**” and “**▲**” keys simultaneously and hold them for more than 3 seconds to enter the menu display, the screen appears “**CF**” code, press the “**Set**” key to display the working mode, press the “**▲**” or “**▼**” to adjust the display, “**C**” means Celsius mode; “**F**” means Fahrenheit mode. Press “**Rst**” to save the setting and exit. **Factory Default = “F”**.

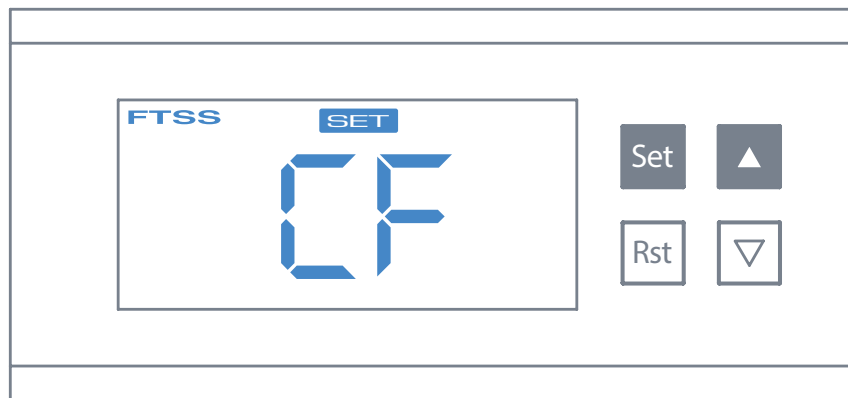

COOLING OR HEATING MODE

Press “**Set**” key and hold more than 3 seconds to enter the menu display, the screen appears “**HC**” code, press the “**Set**” key to display the working mode, press the “**▲**” or “**▼**” to adjust the display. “**C**” means cooling mode; “**H**” means heating mode. **Factory Default = “C”**.



HYSTERESIS SETTINGS

Press “**Set**” key and hold more than 3 seconds to enter the menu display, with “**▲**” or “**▼**” key adjusted to the screen, appearing “**d**” code, press the “**Set**” key to display the hysteresis set value, press “**▲**” or “**▼**” key to adjust the parameters. **Factory Default = “1°”**.

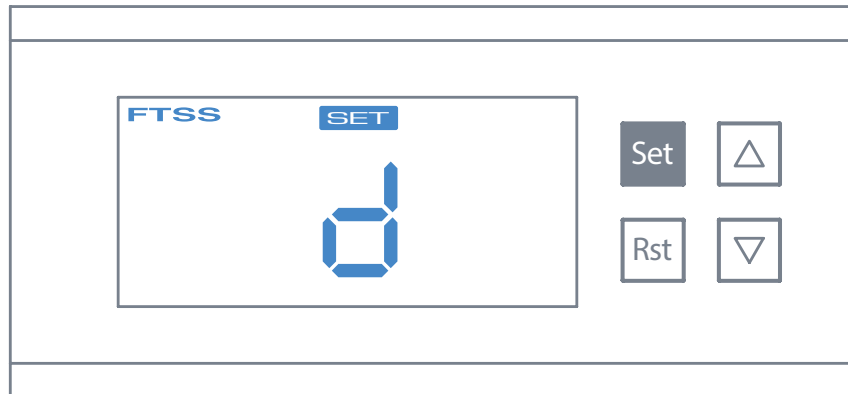

TEMPERATURE CALIBRATION SETTINGS

Press “**Set**” key and hold more than 3 seconds to enter the menu display, with “**▲**” or “**▼**” key adjusted to the screen, appearing “**CA**” code, press the “**Set**” key to display the temperature calibration settings, press “**▲**” or “**▼**” key to adjust the parameters. **Factory Default = “0”**.

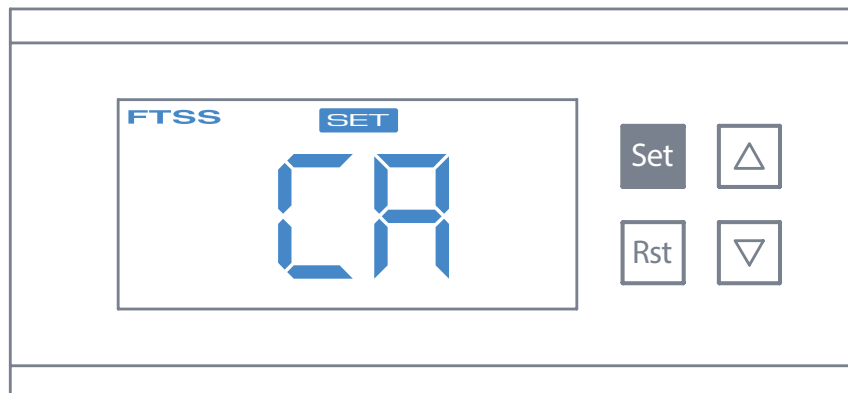

DELAY PROTECTION SETTING

Press “Set” key and hold more than 3 seconds to enter the menu display, with “▲” or “▼” key adjusted to the screen, appearing “P7” code, press the “Set” key to display the delay setting value, then press the “▲” or “▼” key to adjust the parameters. **Factory Default = “5” min.**

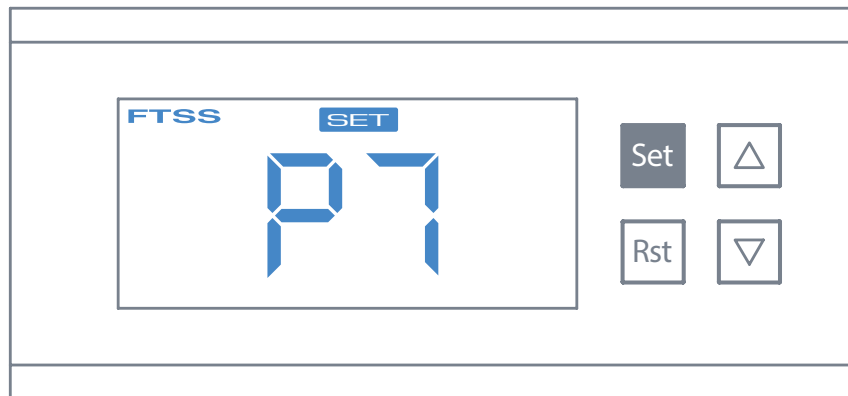

UPPER AND LOWER LIMIT SETTINGS

Press “Set” key and hold more than 3 seconds to enter the menu display, with “▲” or “▼” key adjusted to the screen, appearing “HS” or “LS” code, press the “Set” key to display the upper or lower limit set value, Then press “▲” or “▼” key to adjust the parameters. HS means upper limit. LS means lower limit. **Factory Default = “-44, +299”.**

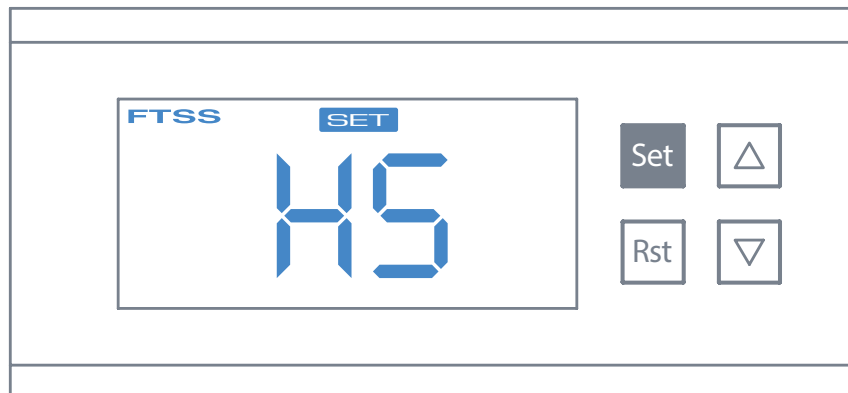

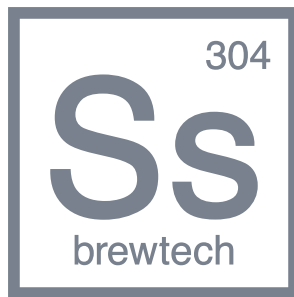

SsBrewtech.com