

### SEMI-RECESSING MOUNTING BOX FOR HK-JA SERIES TO MEET ADA COMPLIANCE

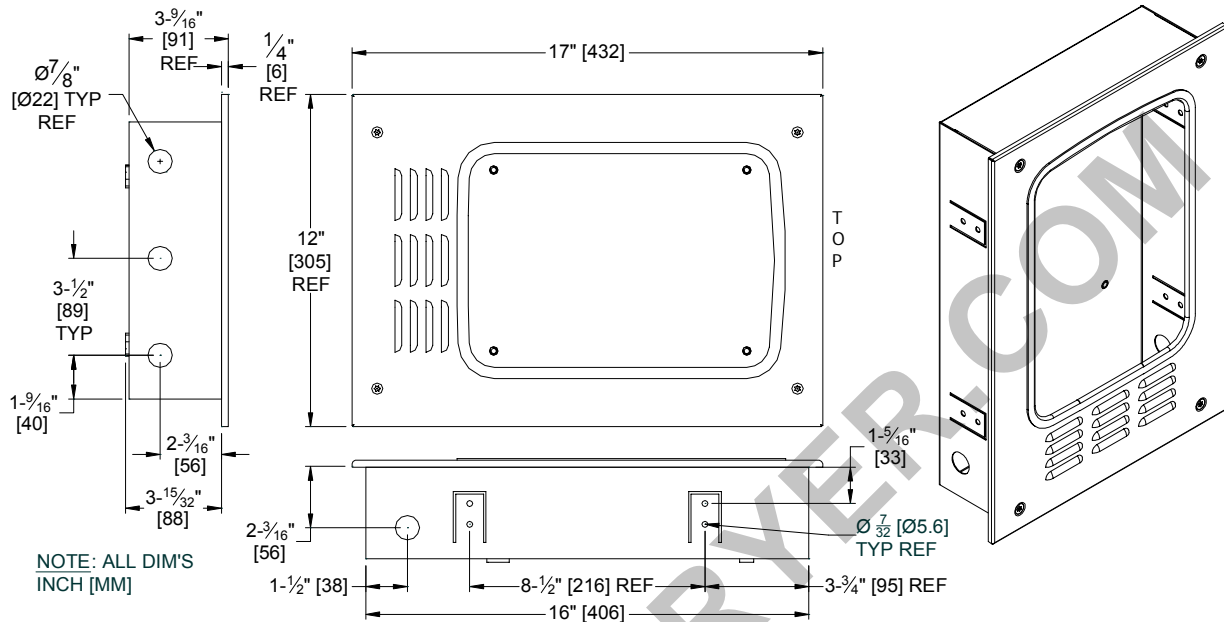

#### SPECIFICATION

Semi-Recessing mounting box shall reduce projection of HK-JA Series hand dryer to less than 4" (102) from wall face for ADA Barrier Free Compliance. Wall Box shall be fabricated of 20 gauge cold rolled steel with white porcelain enamel to match dryer. Wall box shall have eight (8) 7/32" diameter mounting holes provided in sides on adjustable tabs (2 per verticle side) that eliminate requirement for shim fitting for installation purposes. Three (3) 7/8" diameter holes shall be provided on bottom wall and one shall be provided on each bottom sidewall to facilitate power entry location. Mounting holes shall be provided the box rear pan to match the mounting hole pattern of the dryer unit (mounting hardware is supplied the dryer units) and holes shall have captive 1/4-20 threaded fasteners to receive dryer mounting hardware. Full-face cover shall be formed from one piece with no miters, welding or open seams on face and shall have 1/4" (6.4) square returns to wall. Cover shall be retained after closure with four (4) security pin-Torx 1/4-20 flat head crews flush with panel face and shall have black rubber vibration isolation gasket. Structural assembly of all components shall be welded construction. Cabinet shall have no exposed-welded seams.

#### INSTALLATION

Install mounting box in wall recess using N° 10 fasteners appropriate for the wall conditions (supplied by installer) through concealed mounting holes provided. Electrical service is made by qualified electrician through knockouts provided with use of appropriate connector (supplied by installer) to meet codes having jurisdiction and left rough with a 14" (356) pull. For compliance with ADA Accessibility Guidelines bottom of Rough Wall Opening (RWO) should be located 44" (1118) maximum AFF or 36" (1118) maximum AFF for CalDAG compliance. Note that top of RWO is 5/16" (8) below top of unit. Dryer unit chassis (not supplied with this unit) is installed after recessing box installation is complete. Stub cable is brought from KO location to bottom dryer chassis location (see 0197 mounting template, provided with dryer), secured to strain relief and terminated to terminal block by qualified electrician. Dryer cover is installed using security screws (provided with dryer) after electrical hookup. Cover with vibration isolation gasket is mounted to box with four (4) security screws (supplied) for service accessibility to complete installation.

**RWO required is 10-3/4" W x 16-3/8" H x 3-3/4" D minimum (273 x 416 x 95)**

#### OPERATION

Unit remains integral to wall framing after installation. There are no moving or adjustable parts requiring owner access or service. Air intake hole pattern in cover should be kept clean on regular maintenance schedule.