

CP0016HCS-ASTM

General Description

- Surface-mounted, horizontal-folding baby changing stations made of bacterial-resistant white polypropylene (interior) and AISI 304 stainless steel with a satin finish (exterior). exterior with a satin (brushed) finish.
- High level of safety and cleanliness.
- Models offer great strength and durability, suitable for high traffic facilities.
- Trendy and stylish design.
- Biocote® antimicrobial additive is embedded into the polypropylene surface.
- Includes a pair of bag hooks to keep personal belongings off the floor and close at hand.
- In full compliance with the American standard ASTM F2285-04 and the European standards EN 12221-1 and EN 12221-2.

Components & Materials

- **CP0016HCS:** horizontal-folding, surface-mounted baby changing station made with a polypropylene interior and an AISI 304 stainless steel exterior with a satin (brushed) finish.
- **BED:** with approximately 295 in² contoured changing surface area is made of polypropylene in white finish with Biocote® antimicrobial additive embedded into its surface, promoting easy cleaning and reducing the growth of odor-causing and staining microbes.
- **LINER DISPENSER:** is made of polypropylene and holds approximately 80 bed liners, minimizing operator refills and discouraging potential vandalism.
- **OPEN/CLOSE MECHANISM:** concealed from the user's view, it consists of a pair of reinforced hinges and a pneumatic cylinder, ensuring high durability and a smooth opening and closing of the baby changing station.
- **MOUNTING CHASSIS:** made of steel with a cathaphoresic treatment. The corresponding mounting hardware is supplied, making the unit installation to the wall easy.
- **FRONTAL CHASSIS:** (CP0016HCS) made of one-piece AISI stainless steel (satin), 1/32" thick, fixed to the bottom of the bed by means of 4 bolts and 4 nuts which are always concealed from the user's view for safety. Without visible joints or edges, this unit is easier to clean and makes for a seamless blending with other stainless steel accessories in the washroom.



code

CP0016HCS-ASTM

material
 polypropylene /
 stainless steel
 finish
 white / satin

Technical Specifications

Dimensions	L:33 7/8" x W:3 7/8" (closed) / 22 1/2" (open) x H:18 7/8"
Weight (empty)	35.3 lbs. (CP0016HCS)
Liner dispenser capacity	80 units
Recommended installation height	31 1/2" at lowest point
Recommended installation height (handicapped)	27 1/2" at lowest point

Operation

Open the BabyMedi® baby changing station. Place the baby on the centre of the bed and change your baby's diapers. Close the BabyMedi® station.

Under no circumstance should the baby be left unattended at any time on top of the baby changing station in order to avoid injury from falling or slipping.

Saniflow Corp reserves the right to make changes and/or modifications to the products and their specifications without warning or notice.

Installation

According to the installation and safety instructions manual supplied with the unit.

IMPORTANT: in order to ensure BabyMedi is properly installed it is recommended that a qualified person carries out the installation of the unit. The unit must be properly installed on a wall that is able to sustain a considerable weight and can accommodate the supplied installation hardware.

Certificates & Qualifications

Unit shall be ASTM approved, according F2285-04 standard and GS according EN 12221-1 and EN 12221-2 standards.

Ideal location

Public spaces such as, shopping centers, airports, public buildings, childcare centers, etc. Models suitable for high traffic facilities with high strength and durability.

IMPORTANT: the Congress of the United has taken a further step towards gender equality by implementing law 114-235 (10/07/2016). By this law, the American Government states that restrooms, both for men and women, in public buildings all around the country, must have diaper changing facilities in place.

Guide specification

Surface-mounted, horizontal-folding baby changing stations made of bacterial-resistant white polypropylene (interior) and stainless steel AISI 304 (exterior) with a satin (brushed) finish.

BabyMedi® changing stations offer a very high level of safety and cleanliness being the ideal solution for public spaces such as, shopping centers, airports, public buildings, childcare centers, etc. Models are suitable for high traffic facilities where great strength and durability is needed.

Their trendy and stylish design, allow these baby changing stations to blend into any space perfectly.

Biocote® antimicrobial additive, based on ion silver technology, is embedded into the surface, promoting an easy cleaning and reducing the growth of odor causing and staining microbes.

BabyMedi® baby changing stations are supplied with child protection straps made of nylon assembled.

A pair of bag hooks (one at the right side and the other one at the left) help to keep personal belongings close and at hand.

BabyMedi® units fully compliant with the American standard ASTM F2285-04 and the European EN 12221-1 and EN 12221-2 standards that require baby changing stations be able to support a 110 lb static load test during one hour. Moreover, units tested in our own laboratories have withstood loads over 220 lb.

Overall dimensions:

L: 33 7/8" x W: 3 7/8" (closed) / 22 1/2" (open) x H: 18 7/8"

Weight: 35.3 Lbs. (CP0016HCS)

Recommended heights from floor

	Male	Female	Disabled
X To bottom of unit	31 1/2" (800 mm)	31 1/2" (800 mm)	27 1/2" (700 mm)
Y To mounting brackets	47 13/16" (1215 mm)	47 13/16" (1215 mm)	43 7/8" (1115 mm)

MOUNTING

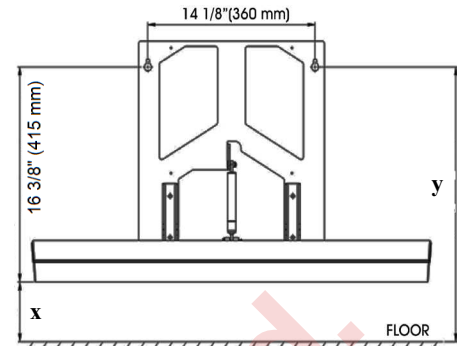

CP0016HCS-ASTM

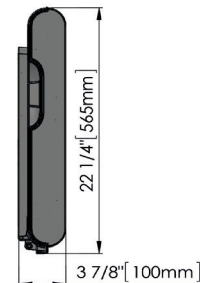
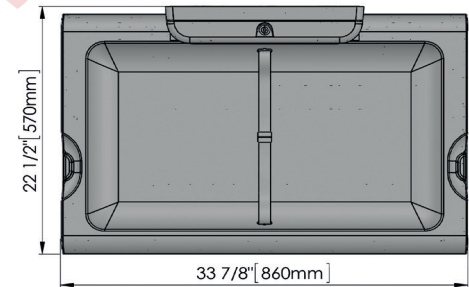
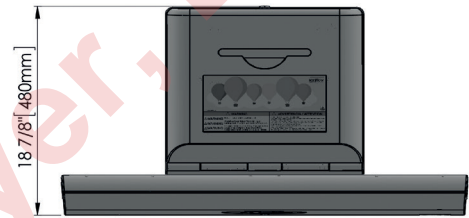

Job: _____

Architect / Engineer: _____

City / State / Country: _____

Model number: _____

Contractor: _____

Date: _____

Variations: _____

Customer / Wholesaler: _____

Quantity: _____

Saniflow Corp reserves the right to make changes and/or modifications to the products and their specifications without warning or notice.

Allied Hand Dryer, Ltd.
706 W Summit Ave
San Antonio, TX 78212

800.535.4393
210.733.5918
210.308.5924 Fax

www.handdryer.com
sales@handdryer.com