



TriStar® VS 900

»»» Variable-Speed Pump

INDUSTRY-LEADING ENERGY EFFICIENCY IN A PREMIUM PUMP

No-rib strainer basket with see-through cover ensures easy debris removal

Permanent magnet, totally enclosed fan-cooled motor offers more efficient operation and long-lasting reliability

Advanced hydraulic design provides ample power to replace most high-performance pumps up to 1.5 full-rate or 2.0 max-rate HP



Wall-mountable touchpad control can be rotated in four directions

Side and rear conduit entry accommodate both high and low voltage connections for simple installation

Upgraded dual-voltage motor drive delivers 30% quieter high-speed operation than other models



EXPERT LINE
ONLY FROM POOL PROS



INDUSTRY-LEADING ENERGY EFFICIENCY
As part of the TriStar family of pumps—the most energy-efficient pumps in their class—TriStar VS 900 saves pool owners up to \$1,500 per year. Its ENERGY STAR rating means local energy rebates may apply, too.

DESIGNED FOR DURABILITY
Built with a chemical-resistant Viton® seal and accompanied by a 3-year extended warranty, TriStar VS 900 offers powerful corrosion protection for years of reliable performance.

SEAMLESS RETROFITTING
With easy top-mount wiring, two pump base options and 2" x 2½" CPVC union connections, TriStar VS 900 is easy to install in both new and existing pool pads.



SPECIFICATIONS

MODEL NUMBER	TOTAL HP	VOLTAGE	WEIGHTED ENERGY FACTOR (WEF)*	UNION CONNECTIONS	WARRANTY
SP32900VSP	1.85	115/230V	12.9/8.3	2" x 2.5"	3 years**

*The higher the weighted energy factor (WEF), the more efficient the pump. Visit hayward.com/regulations for more information.

TRISTAR VS 900 DIMENSIONS (INCHES)

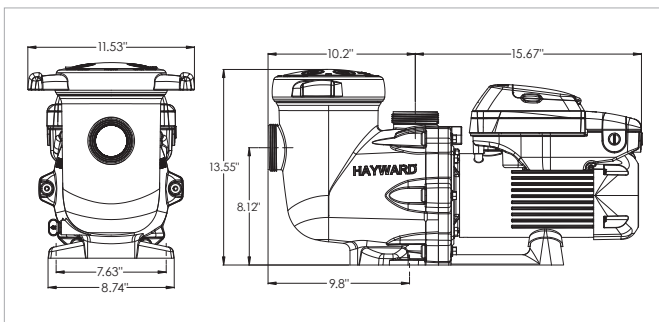

TriStar VS 900 pumps are listed by:

**When sold by a Totally Hayward® partner. Exclusions, other terms and conditions may apply — visit hayward.com/expert for details.

TRISTAR VS 900 PERFORMANCE COMPARISON

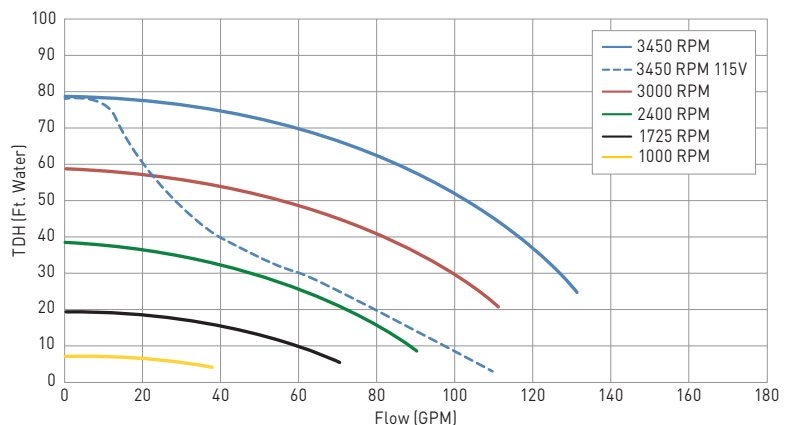

» hayward.com » 1-888-HAYWARD | Pumps » Filters » Heating » Cleaners » Sanitization » Automation » Lighting » Water Features » White Goods

Hayward, Hayward & Design, the H logo, Totally Hayward and TriStar are registered trademarks of Hayward Industries, Inc. ENERGY STAR is a registered mark owned by the U.S. government. All other trademarks not owned by Hayward are the property of their respective owners. Hayward is not in any way affiliated with or endorsed by those third parties. © 2020 Hayward Industries, Inc. eLITTSVS90020