

TAMAÑO: 420 X 297mm

Forma de insertar hebilla y tirante para tubos mostrados. (ver figura 8a)

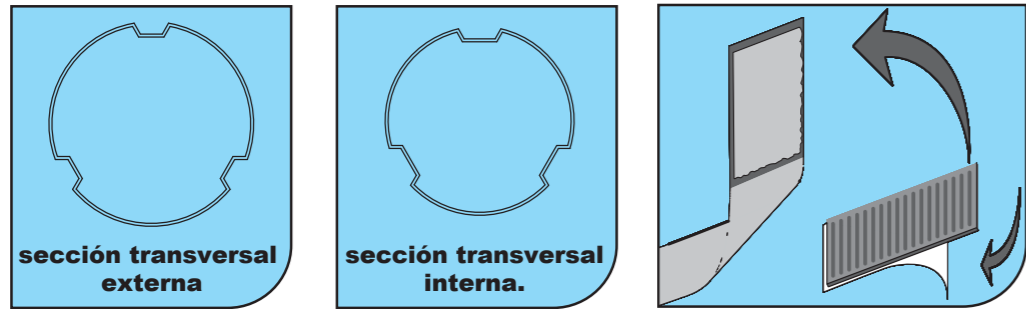

8a

Forma de insertar hebilla y tirante para tubos mostrados. (ver figura 8b)

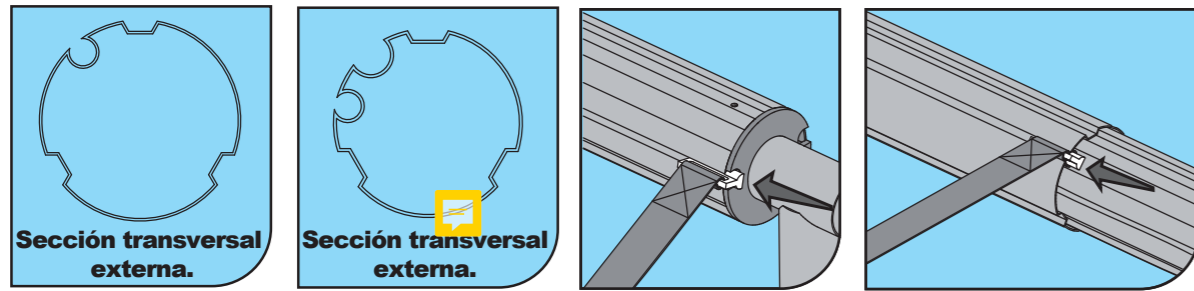

8b

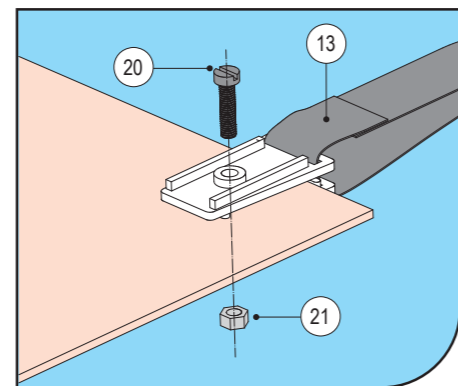
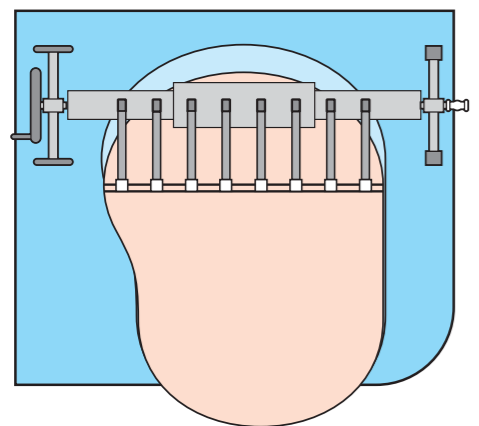
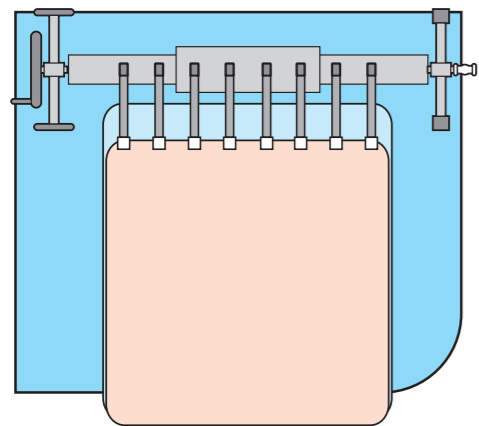
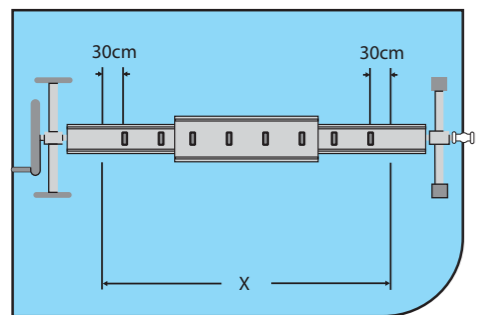

9a

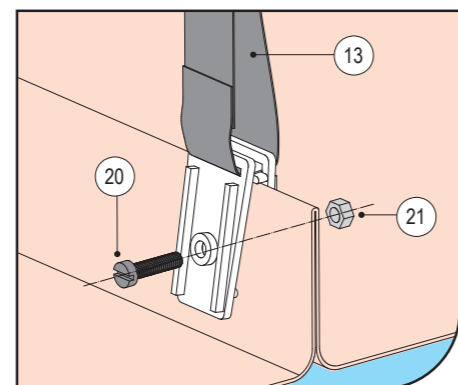

9b

Enrollador para cubierta térmica

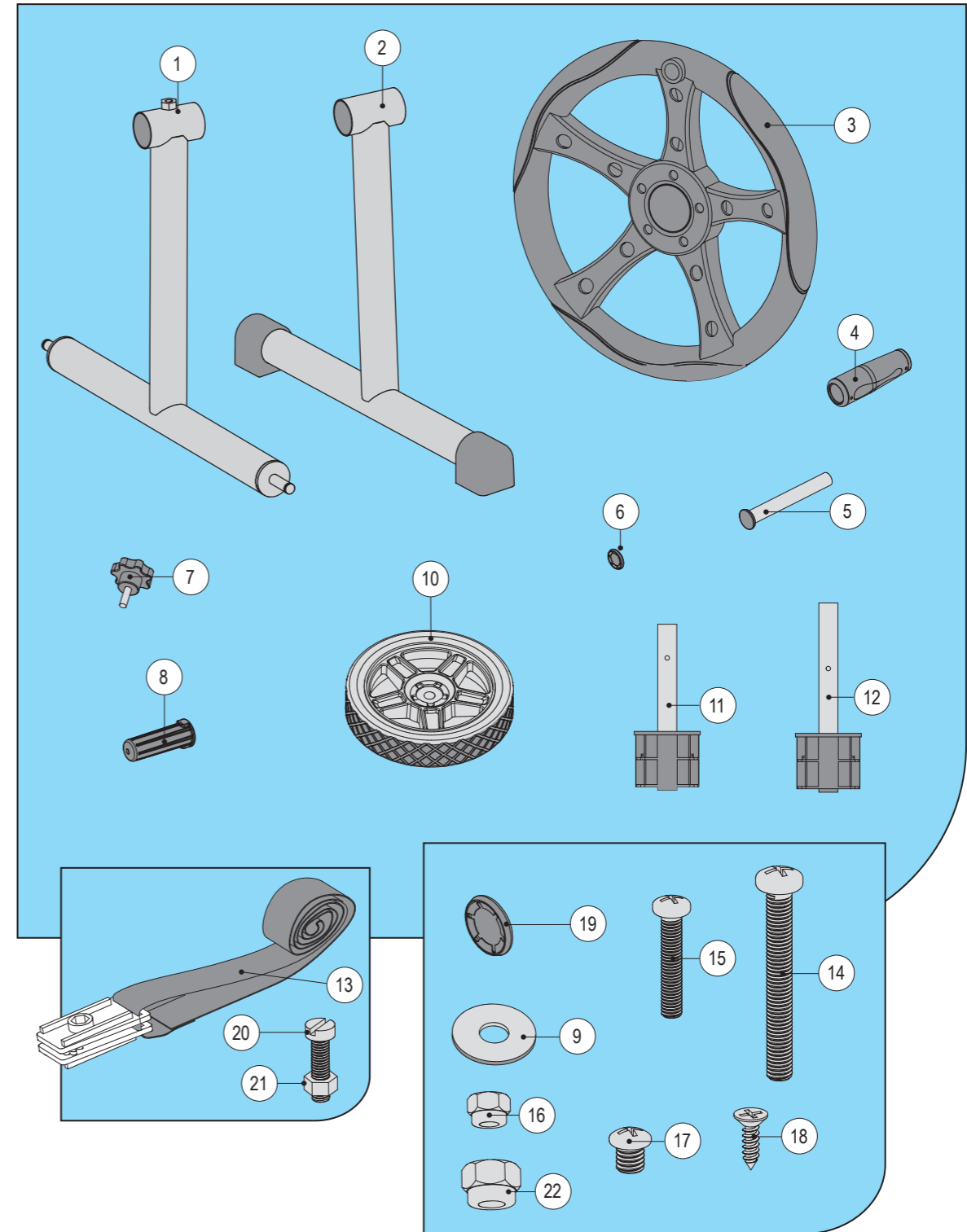

1

Ref	Qty
1#	1
2#	1
3#	1
4#	1
5#	1
6#	1
7#	1
8#	1
9#	1
10#	2
11#	1
12#	1
13#	8
14#	1
15#	1
16#	1
17#	6
18#	6
19#	2
20#	8
21#	8
22#	1

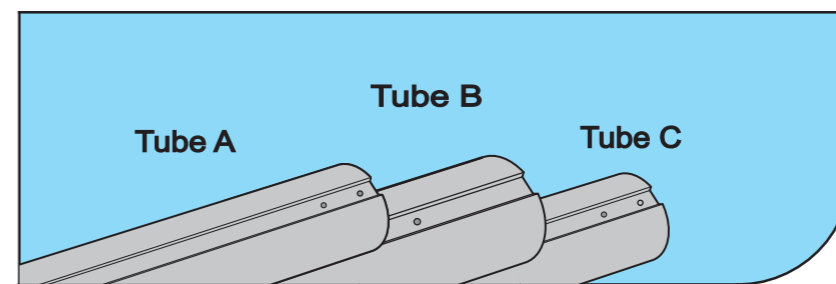

HFX
water equipment

Parte Frontal

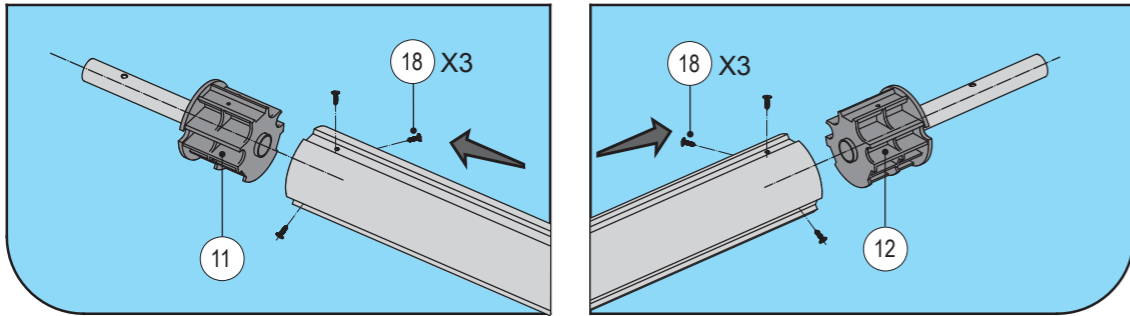

2

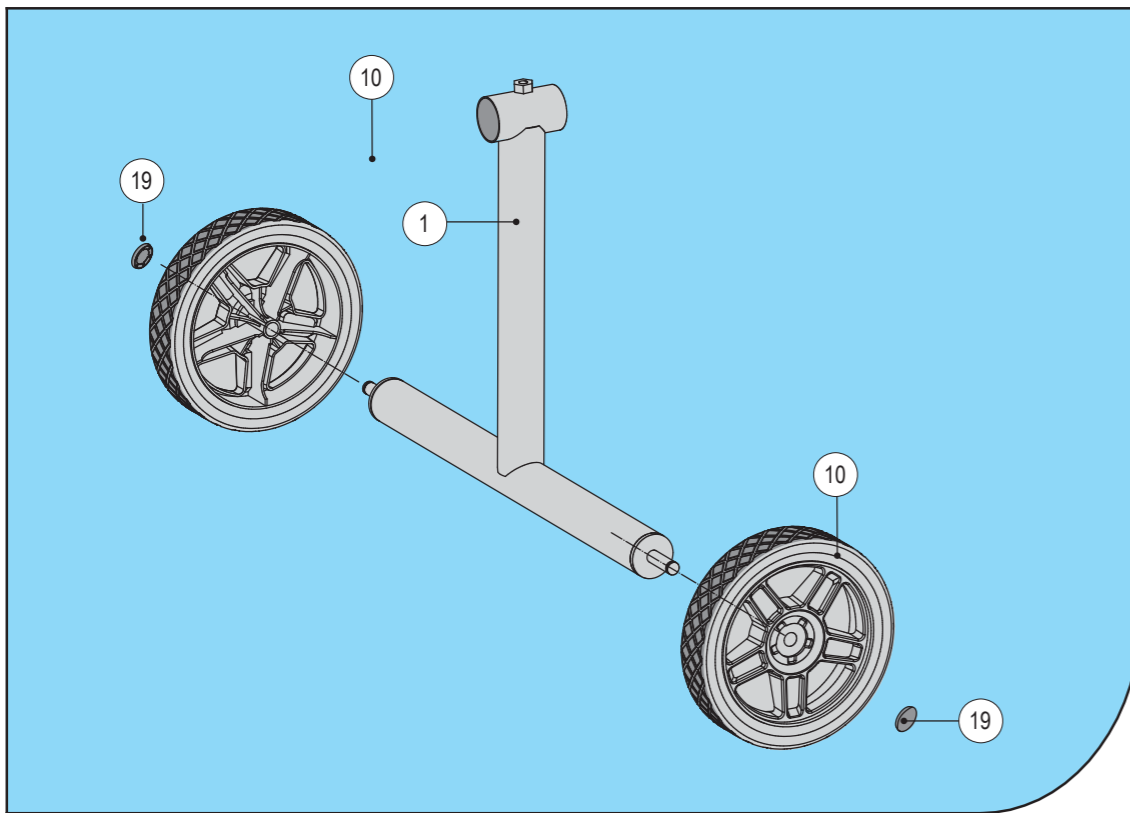

3

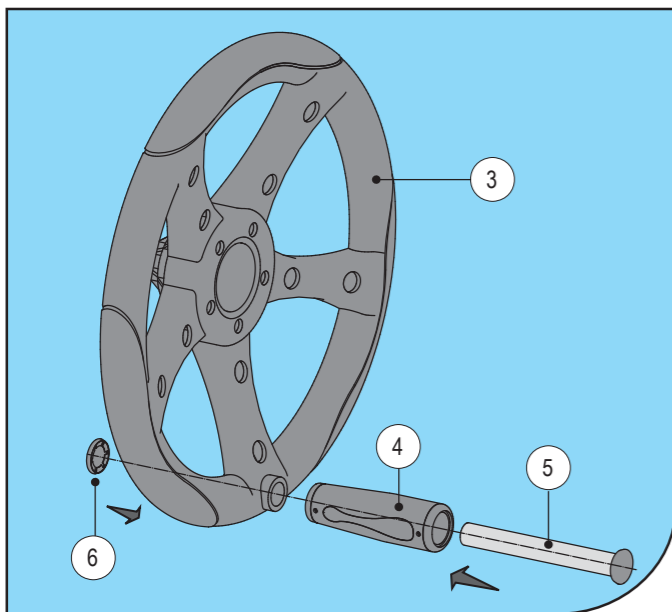

4

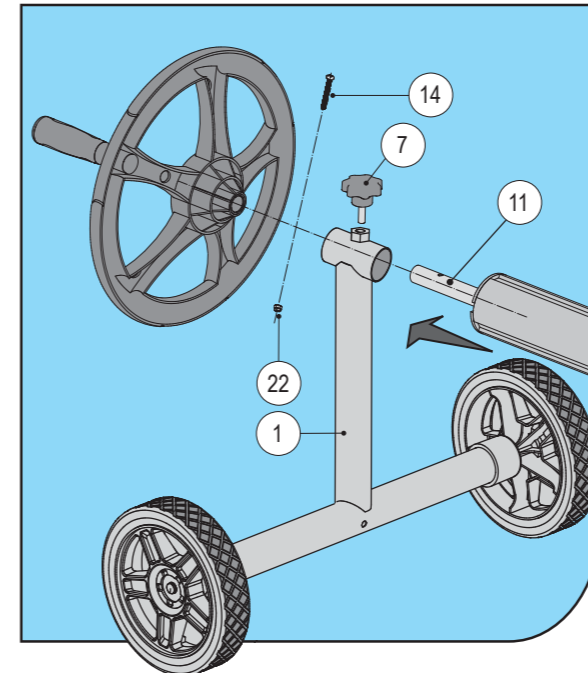

5

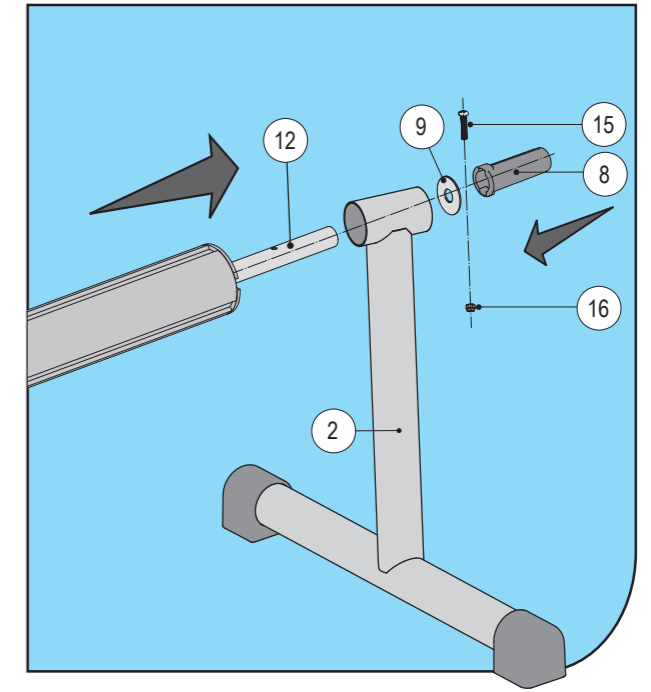

6

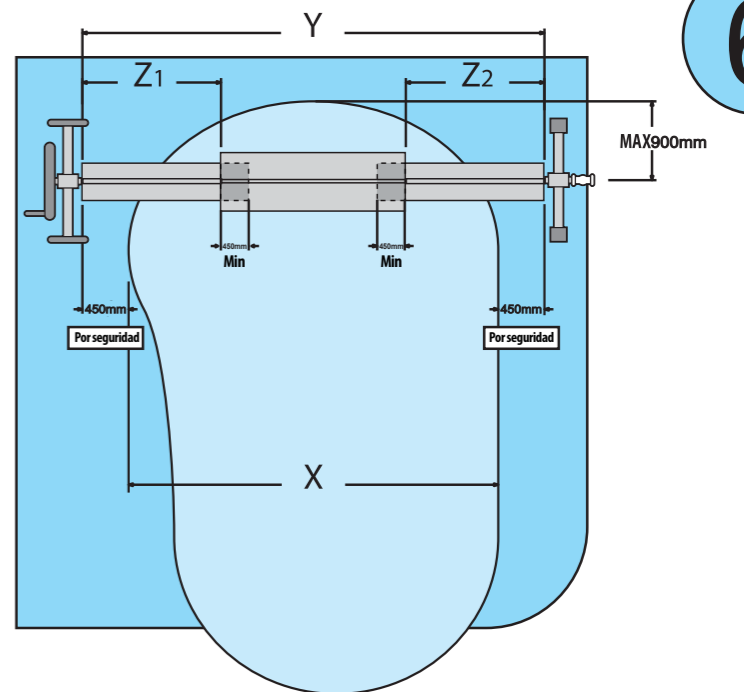
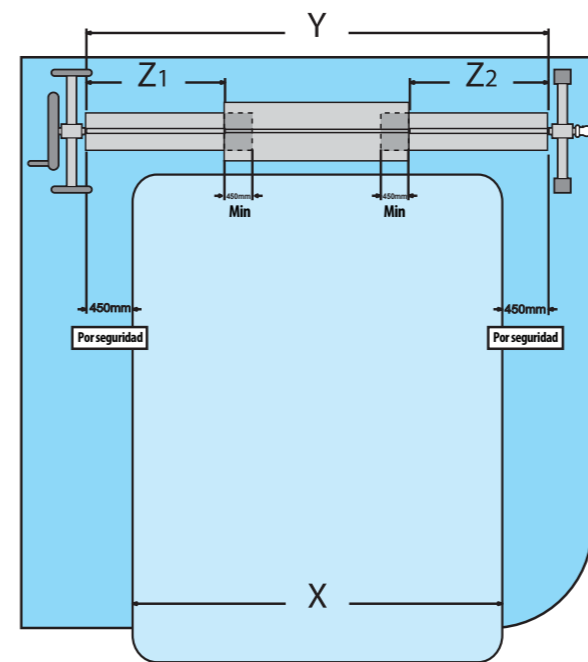

7

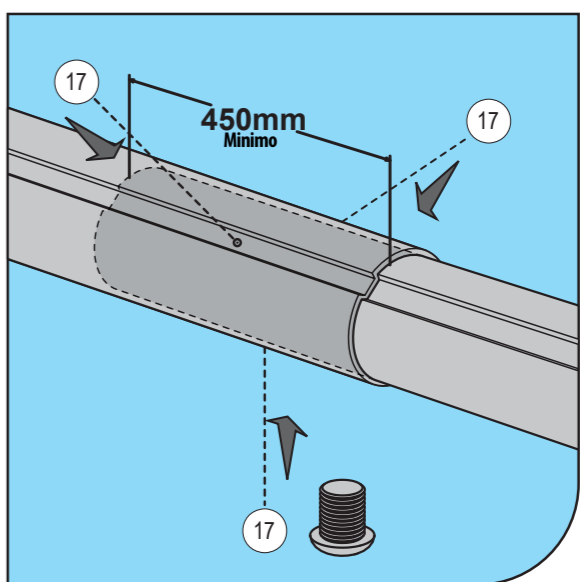
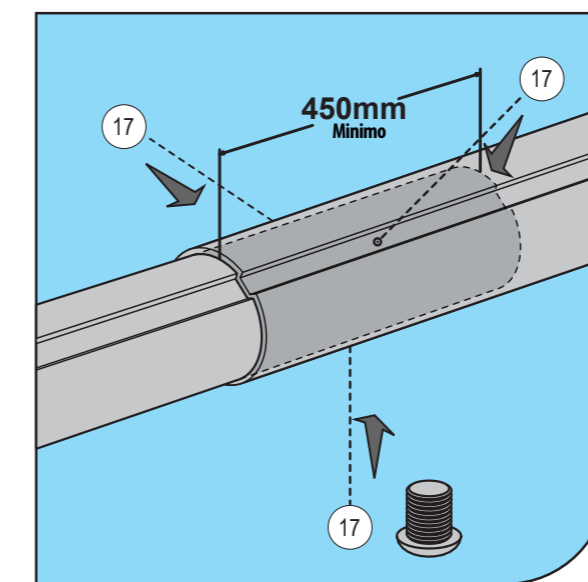

Parte Frontal