



Dynamo Motion Sensor Instruction Manual



www.integratedpower.net.au

Features

- Sensor can be commissioned and changed from remote control
- Easily retrofitted to many brands of LED highbays
- Can control dimming of fittings (if 1-10V dimmable driver fitted)
- Built-in daylight sensor

SPECIFICATIONS

Input voltage	220-240Vac, 50/60Hz
Rated load	800W@220-240Vac (Inductive load) 1000W@220-240Vac (Resistive load)
Detection area	8m Max. (radius) adjustable
Hold time	5s/ 30s/ 1min/ 3min/ 5min/ 10min/ 20min/ 30min
Daylight sensor	5lux/ 15lux/ 30lux/ 50lux/ 100lux/ 150lux/ Disable
Stand-by period	0s/ 10s/ 1min/ 3min/ 5min/ 10min/ 30min/ +∞
Stand-by dimming level	10% / 20% / 30% / 50%
Sensor principle	Microwave motion detector
Microwave frequency	5.8GHz±75MHz, ISM wave band
Transmitting power	<0.5mW (1% of transmitting power for cell phone)
Mounting height	3-15m
Detection angle	150°(Wall installation), 360°(Ceiling installation)

GENERAL GUIDELINES FOR INSTALLATION

1. Please read the entire instruction manual before using the product and then save it for future reference. We reserve the right for any errors in text or images and any necessary changes made to technical data.
2. The sensor should be installed by a qualified electrician. And ensure that the electricity supply is switched off before installing or servicing the product.
3. The sensor should not be modified in any way. Any modifications made to this product will immediately invalidate any warranties issued.
4. The company does not accept responsibility for any consequences resulting from unauthorized modification of the product.
5. Microwaves cannot pass through metal or brick walls if thicker than 20cm. They will pass through thinner walls but there will be some attenuation.
6. The sensor is designed for indoor use only. The raining or wind blowing may trigger the microwave motion sensor even if without human motion when outdoor use.
7. The sensor should be connected to a stable power supply of 220-240Vac, 50/ 60Hz.
8. Detection area will be affected by speed of motion, height of installation and volume of moving object.
9. Daylight sensor is tested on sunny environment with no lampshade.

DETECTION PATTERN

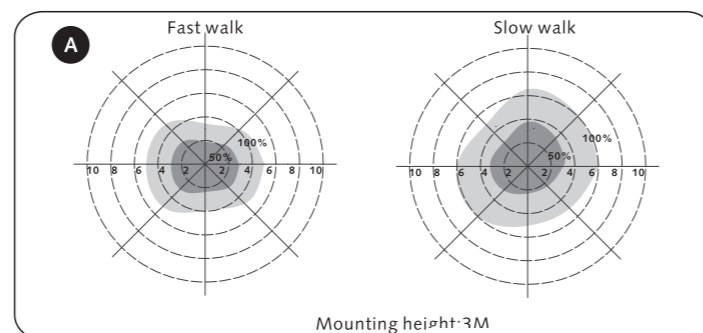

DETECTION PATTERN

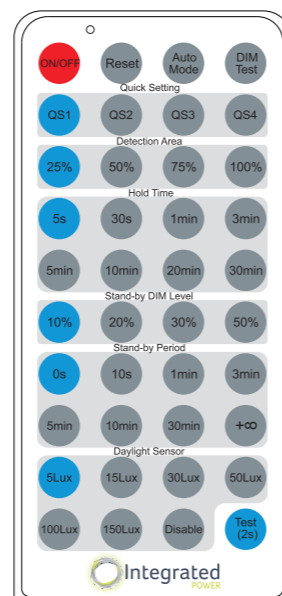
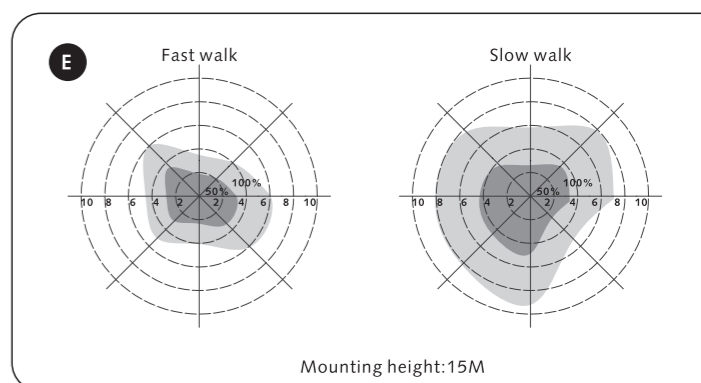
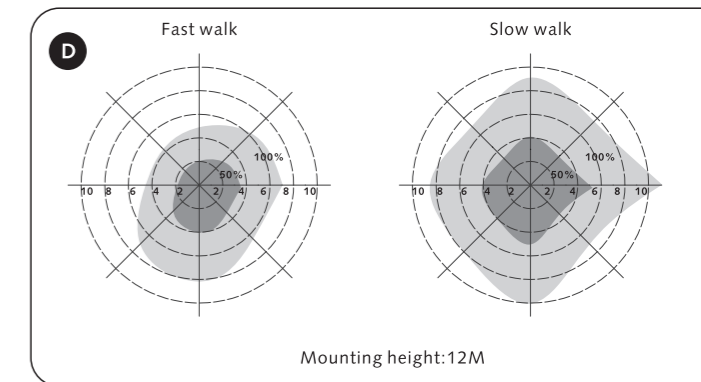
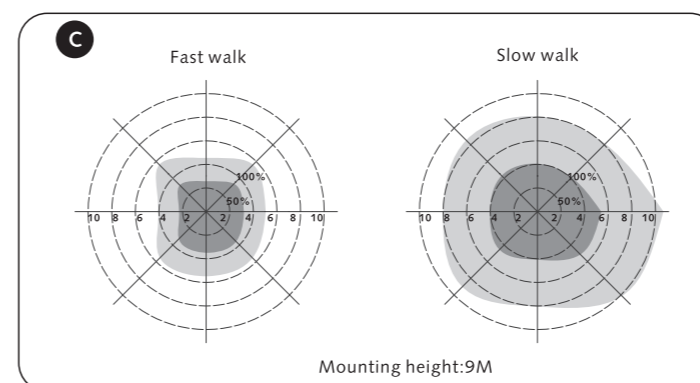
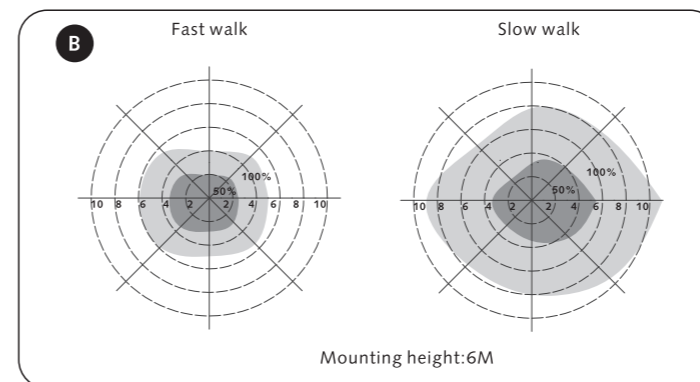

The motion sensor will flash 3 times each time a command is sent from the remote.

Button	Remarks																														
	Press the "ON/OFF" button, the light goes to constant on or constant off mode, sensor is disabled. Press "Reset" or "Auto Mode" button to quit from this mode.																														
	Press "Reset" button, all parameters are same as setting of DIP switch.																														
	Press "Auto Mode" button, the sensor starts to work and all parameter setting will be remained the same as the previous status before the light was switched on/off.																														
	Press "DIM Test" button to test dimming function. Sensor will dim automatically and return to normal work mode.																														
	The button "Test(2s)" is for factory testing purpose only. The sensor will go to test mode, Detection sensitivity: 100% Hold time: 2sec stand-by dim level: 10% Stand-by period: 0s Daylight sensor: Disable Test mode can be quit by pressing any button.																														
	<table border="1"> <thead> <tr> <th>scene Options</th> <th>Detection Area</th> <th>Hold Time</th> <th>Stand-by period</th> <th>Stand-by dim level</th> <th>Daylight Sensor</th> </tr> </thead> <tbody> <tr> <td>QS1</td> <td>100%</td> <td>30s</td> <td>1min</td> <td>10%</td> <td>5Lux</td> </tr> <tr> <td>QS2</td> <td>100%</td> <td>1min</td> <td>3min</td> <td>10%</td> <td>10Lux</td> </tr> <tr> <td>QS3</td> <td>100%</td> <td>5min</td> <td>10min</td> <td>10%</td> <td>30Lux</td> </tr> <tr> <td>QS4</td> <td>100%</td> <td>10min</td> <td>30min</td> <td>10%</td> <td>Disable</td> </tr> </tbody> </table> <p>Note: Detection area / Hold time / Stand-by period / Stand-by dim level / Daylight sensor can be adjust by pressing corresponding button. The latest setting stays in validity.</p>	scene Options	Detection Area	Hold Time	Stand-by period	Stand-by dim level	Daylight Sensor	QS1	100%	30s	1min	10%	5Lux	QS2	100%	1min	3min	10%	10Lux	QS3	100%	5min	10min	10%	30Lux	QS4	100%	10min	30min	10%	Disable
scene Options	Detection Area	Hold Time	Stand-by period	Stand-by dim level	Daylight Sensor																										
QS1	100%	30s	1min	10%	5Lux																										
QS2	100%	1min	3min	10%	10Lux																										
QS3	100%	5min	10min	10%	30Lux																										
QS4	100%	10min	30min	10%	Disable																										

As the control angle of the Infrared Remote Control is fixed (15°), if sensors are installed too close to each other, settings of both sensors will be configured. Please refer to the below chart for the distance of the installation of the sensor:

Mounting height	Distance between sensors
15m	4m
12m	3.4m
9m	2.4m
6m	1.6m
3m	0.8m

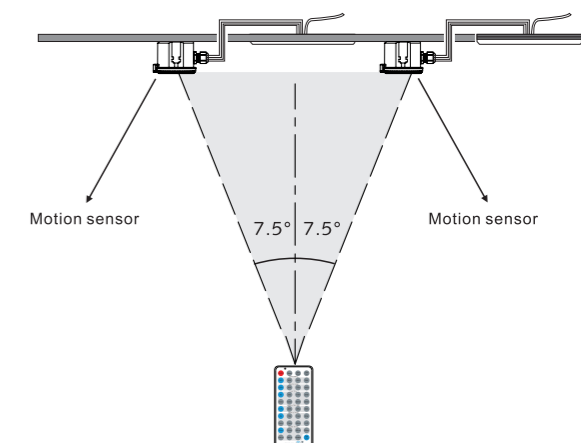

INSTALLATION

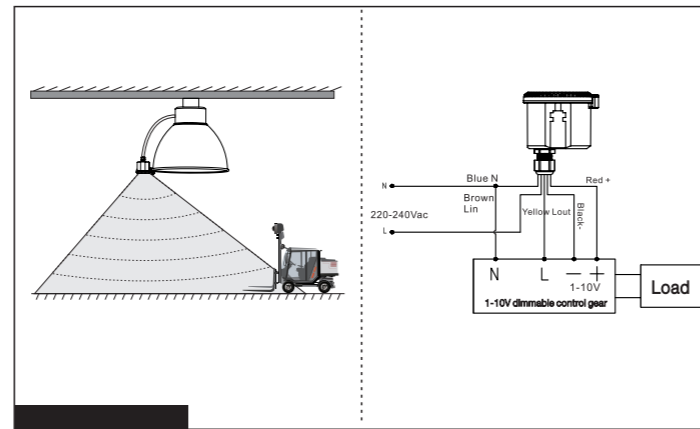
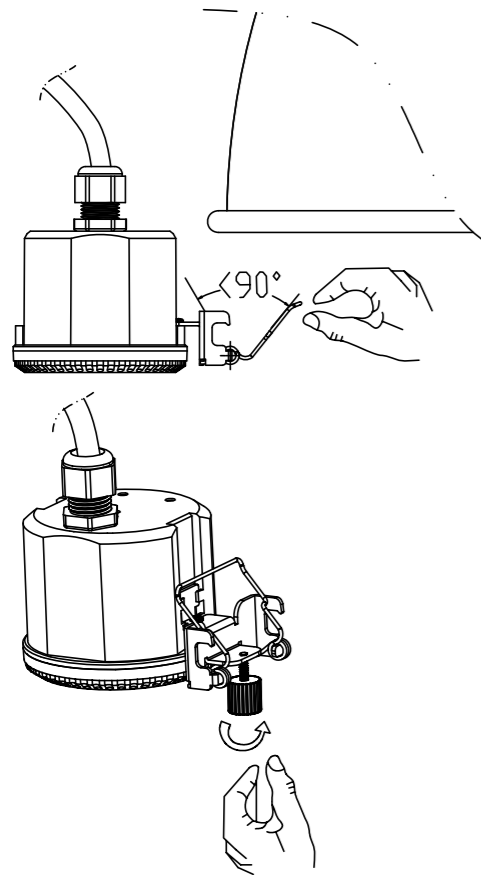

- Use the 'piggy back' plug to connect the sensor to the mains supply and the LED highbay.

- If the highbay has a 1-10V dimmable ballast, connect the LV cable to the dimming cable on the highbay for dimming control. The dimming cable does not need to be used for the sensor to function (it will just not have the dimming functionality)

- Use the remote control (or the dip switched inside the unit) to set the sensor as required

Warranty Statement "Integrated Power Pty Ltd" ABN – 72 604 326 061

This product is warranted to be free from defects in materials and workmanship from the date of installation (or the date of manufacture if installation date is unknown) for a period of 3 (three) years. Goods that prove defective within the warranty period by reason of improper workmanship or faulty material, we may, at our own discretion, either repair or replace the goods without charge, subject to the terms and conditions below:

1. The product is properly installed, and installation is consistent with the manufacturer's instructions, and is installed by suitably trained and qualified installer.
2. The product is not subjected to any unauthorized modifications.
3. The product is only used for the purpose of illumination, in line with its designated purpose or the designated purpose of a luminaire of its general type.
4. Any faults or defects attributable to the misuse, abuse, accident or non-observance of the manufacturer's instructions on the part of the user are specifically excluded.

The warranty does not cover:

1. Damage caused by acts of god, or other incidents / occurrences beyond the control of Integrated Power, including without limitation, fire, theft, storms, floods or power surges.
2. Damage caused by chemical impact or other abuse including environmental factors, improper cleaning solutions, damage from leaving substances such as bleach on the product.
3. Damage or problems caused by the use of an accessory, component or equipment not supplied by Integrated Power
4. Integrated Power do not cover freight charges (including insurance) or labour/plant hire for repair or replacement of this item.

Our goods come with guarantees that cannot be excluded under the Australian Consumer Law. You are entitled to a replacement or refund for a major failure and compensation for any other reasonably foreseeable loss or damage. You are also entitled to have the goods repaired or replaced if the goods fail to be of acceptable quality and the failure does not amount to a major failure.

SETTINGS (DIP SWITCH)

Detection area, hold time, stand-by period, stand-by DIM level and daylight sensor can be set by using DIP switches on the sensor. Note that reducing the detection area will also reduce the sensitivity.

	<table border="1"> <tr><th></th><th>1</th></tr> <tr><td>I</td><td>ON 100%</td></tr> <tr><td>II</td><td>- 50%</td></tr> </table>		1	I	ON 100%	II	- 50%	<p>Detection area</p> <p>I: up to 100%</p> <p>II: up to 50%</p>																													
	1																																				
I	ON 100%																																				
II	- 50%																																				
	<table border="1"> <tr><th></th><th>2</th><th>3</th><th>4</th><th></th></tr> <tr><td>I</td><td>ON</td><td>ON</td><td>ON</td><td>5S</td></tr> <tr><td>II</td><td>-</td><td>ON</td><td>ON</td><td>30S</td></tr> <tr><td>III</td><td>ON</td><td>-</td><td>ON</td><td>1min</td></tr> <tr><td>IV</td><td>-</td><td>-</td><td>ON</td><td>3min</td></tr> <tr><td>V</td><td>ON</td><td>ON</td><td>-</td><td>20min</td></tr> <tr><td>VI</td><td>-</td><td>-</td><td>-</td><td>30min</td></tr> </table>		2	3	4		I	ON	ON	ON	5S	II	-	ON	ON	30S	III	ON	-	ON	1min	IV	-	-	ON	3min	V	ON	ON	-	20min	VI	-	-	-	30min	<p>Hold time</p> <p>Refers to the time period the lamp remains at 100% illumination after no motion detected.</p> <p>I: 5s</p> <p>II: 30s</p> <p>III: 1min</p> <p>IV: 3min</p> <p>V: 20min</p> <p>VI: 30min</p>
	2	3	4																																		
I	ON	ON	ON	5S																																	
II	-	ON	ON	30S																																	
III	ON	-	ON	1min																																	
IV	-	-	ON	3min																																	
V	ON	ON	-	20min																																	
VI	-	-	-	30min																																	
	<table border="1"> <tr><th></th><th>1</th><th>2</th><th>3</th><th></th></tr> <tr><td>I</td><td>ON</td><td>ON</td><td>ON</td><td>0s</td></tr> <tr><td>II</td><td>-</td><td>ON</td><td>ON</td><td>1min</td></tr> <tr><td>III</td><td>ON</td><td>-</td><td>ON</td><td>3min</td></tr> <tr><td>IV</td><td>-</td><td>-</td><td>ON</td><td>10min</td></tr> <tr><td>V</td><td>ON</td><td>ON</td><td>-</td><td>30min</td></tr> <tr><td>VI</td><td>-</td><td>-</td><td>-</td><td>+∞</td></tr> </table>		1	2	3		I	ON	ON	ON	0s	II	-	ON	ON	1min	III	ON	-	ON	3min	IV	-	-	ON	10min	V	ON	ON	-	30min	VI	-	-	-	+∞	<p>Stand-by period</p> <p>Refers to the time period the lamp remains at a pre-setting dimming level before it completely switches off in the long absence of people</p> <p>I: 0s</p> <p>II: 1min</p> <p>III: 3min</p> <p>IV: 10min</p> <p>V: 30min</p> <p>VI: +∞</p> <p>*When set to 0s, the lamp will work as on/off function</p> <p>*When set daylight sensor to "Disable" and stand-by period to "+∞" the lamp will work as 2-step dimming control (Motion detected, 100% lumens, no motion, remains at pre-setting level lumens)</p>
	1	2	3																																		
I	ON	ON	ON	0s																																	
II	-	ON	ON	1min																																	
III	ON	-	ON	3min																																	
IV	-	-	ON	10min																																	
V	ON	ON	-	30min																																	
VI	-	-	-	+∞																																	

	<table border="1"> <tr><th></th><th>4</th><th>5</th><th></th></tr> <tr><td>I</td><td>ON</td><td>ON</td><td>10%</td></tr> <tr><td>II</td><td>-</td><td>ON</td><td>20%</td></tr> <tr><td>III</td><td>-</td><td>ON</td><td>30%</td></tr> <tr><td>IV</td><td>-</td><td>-</td><td>50%</td></tr> </table>		4	5		I	ON	ON	10%	II	-	ON	20%	III	-	ON	30%	IV	-	-	50%	<p>Stand-by dimming level</p> <p>This is the pre-setting dimming level you would like to have after the hold time in the long absence of people.</p> <p>I: 10%</p> <p>II: 20%</p> <p>III: 30%</p> <p>IV: 50%</p>																												
	4	5																																																
I	ON	ON	10%																																															
II	-	ON	20%																																															
III	-	ON	30%																																															
IV	-	-	50%																																															
	<table border="1"> <tr><th></th><th>6</th><th>7</th><th>8</th><th>9</th><th></th></tr> <tr><td>I</td><td>ON</td><td>ON</td><td>ON</td><td>ON</td><td>5lux</td></tr> <tr><td>II</td><td>-</td><td>ON</td><td>ON</td><td>ON</td><td>15lux</td></tr> <tr><td>III</td><td>ON</td><td>-</td><td>ON</td><td>ON</td><td>30lux</td></tr> <tr><td>IV</td><td>-</td><td>-</td><td>ON</td><td>ON</td><td>50lux</td></tr> <tr><td>V</td><td>ON</td><td>ON</td><td>-</td><td>ON</td><td>100lux</td></tr> <tr><td>VI</td><td>ON</td><td>ON</td><td>ON</td><td>-</td><td>150lux</td></tr> <tr><td>VII</td><td>-</td><td>-</td><td>-</td><td>-</td><td>Disable</td></tr> </table>		6	7	8	9		I	ON	ON	ON	ON	5lux	II	-	ON	ON	ON	15lux	III	ON	-	ON	ON	30lux	IV	-	-	ON	ON	50lux	V	ON	ON	-	ON	100lux	VI	ON	ON	ON	-	150lux	VII	-	-	-	-	Disable	<p>Daylight sensor</p> <p>The sensor can be set to only allow the lamp to illuminate below a defined ambient brightness threshold. The settings are as follows:</p> <p>I: 5lux, darkness operation only</p> <p>II: 15lux, darkness operation only</p> <p>III: 30lux, twilight operation</p> <p>IV: 50lux, twilight operation</p> <p>V: 100lux, twilight operation</p> <p>VI: 150lux, twilight operation</p> <p>VII: Disable*</p> <p>*When set to Disable Mode, the sensor will switch on the lamp when motion is detected regardless of ambient light levels.</p>
	6	7	8	9																																														
I	ON	ON	ON	ON	5lux																																													
II	-	ON	ON	ON	15lux																																													
III	ON	-	ON	ON	30lux																																													
IV	-	-	ON	ON	50lux																																													
V	ON	ON	-	ON	100lux																																													
VI	ON	ON	ON	-	150lux																																													
VII	-	-	-	-	Disable																																													

FAQ

Question	Cause	Remedy
The load will not illuminate.	Incorrect daylight sensor setting selected.	Adjust setting.
	Load has failed.	Replace load.
	Power is switched off.	Switch on.
The load is permanently illuminated.	Continuous movement in the detection area.	Check detection area setting.
	The lamp (containing sensor) is installed in an area too close to reflective surfaces, i.e. metal, glass or concrete walls.	1, Make sure installation area suitable with at least 30cm space between lamp and surrounding reflective surfaces. 2, Reduce sensitivity (detection area).
The load will not illuminate despite movement.	Speed of moving object is not in the range of 0.5~3m/s or the detection radius is too small.	Check detection area setting.
The remote control is not working.	The battery on the remote control is run out.	Change the battery.
	The remote control is not aligned with sensor.	Change the remote angle.