

Premiere Series

CASAMBI TUNEABLE WHITE LED FLOODLIGHT SILVER - 150W

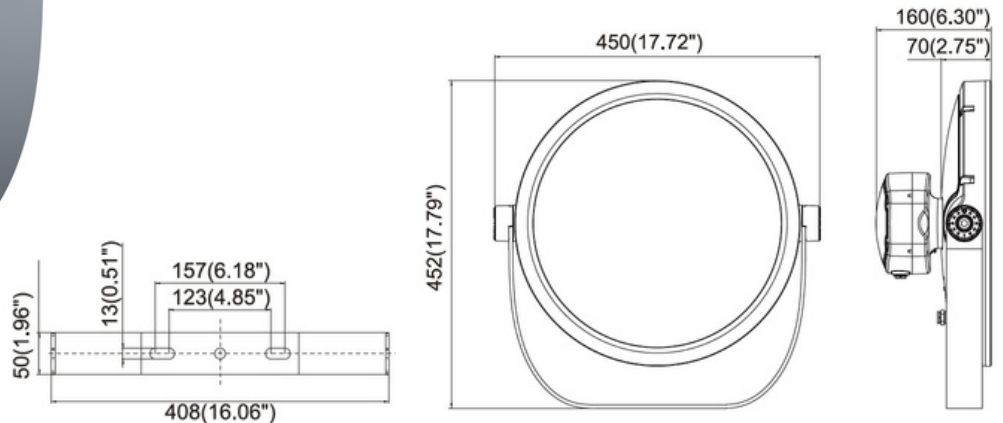

The Premiere Series of LED floodlights by Integrated Power brings you into the world of colour controlled smart lighting. Compatible with multiple smart control systems such as Casambi, DMX and more. The wide range of optics make even the most challenging projects possible. Available in RGBW, RGB and Tuneable White.

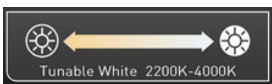

Features

- Heavy duty construction
- High quality LED chips
- Wide range of optics
- Casambi enabled
- Clear lens standard
- Honeycomb lens(excludes 3.8° and 8° narrow optics)
- Adjustable bracket included
- RGB & RGBW models available

Applications

- Facades
- Bridges
- Sports Arenas
- Special Events
- Advertising
- Signage
- Commercial Buildings
- Landscapes



Standard Specifications

- Rated Input Power: 150W
- Lumen Output: 15,000lm (clear lens)
- Lumen Output: 10,500lm (honeycomb lens)
- Colour Temp: 2200K - 4000K
- CRI Rating: CRI>80
- Operating Temperature: -30/+50°C
- EPA (Sail Area): 0.12m²
- Service Life: L70 / 77,000hrs
- IP Rating: IP66
- IK Rating: IK08
- Fitting weight: 10.0kg ± 0.3kg
- Casambi Control

Option List

- DC Input Power/DCV
- Honeycomb Lens/HCL

Models List

Silver / TW / 3.8 Degree Optic	PSC150SITW03
Silver / TW / 8 Degree Optic	PSC150SITW08
Silver / TW / 12 Degree Optic	PSC150SITW12
Silver / TW / 30 Degree Optic	PSC150SITW30
Silver TW / 60 Degree Optic	PSC150SITW60
Silver / TW / 75 Degree Optic	PSC150SITW75
Silver / TW / 15x30 Degree Optic	PSC150SITW1530
Silver / TW / 20x60 Degree Optic	PSC150SITW2060

Accessories

Visor / Glare Shield	PS35VISOR
----------------------	-----------

*Casambi Installation

Casambi control is achieved through an external Casambi device connecting to the DMX control cable which will require a separate housing (not supplied).

IES Files

IES PS150SITW03 4K 150W 3.8deg
IES PS150SITW08 4K 150W 8deg
IES PS150SITW12 4K 150W 12deg
IES PS150SITW30 4K 150W 30deg
IES PS150SITW60 4K 150W 60deg
IES PS150SITW75 4K 150W 75deg
IES PS150SITW1530 4K 150W 15x30deg
IES PS150SITW2060 4K 150W 20x60deg

