

Integrated Power

HF2 SERIES HIGH POWERED LED FLOODLIGHT - 600W

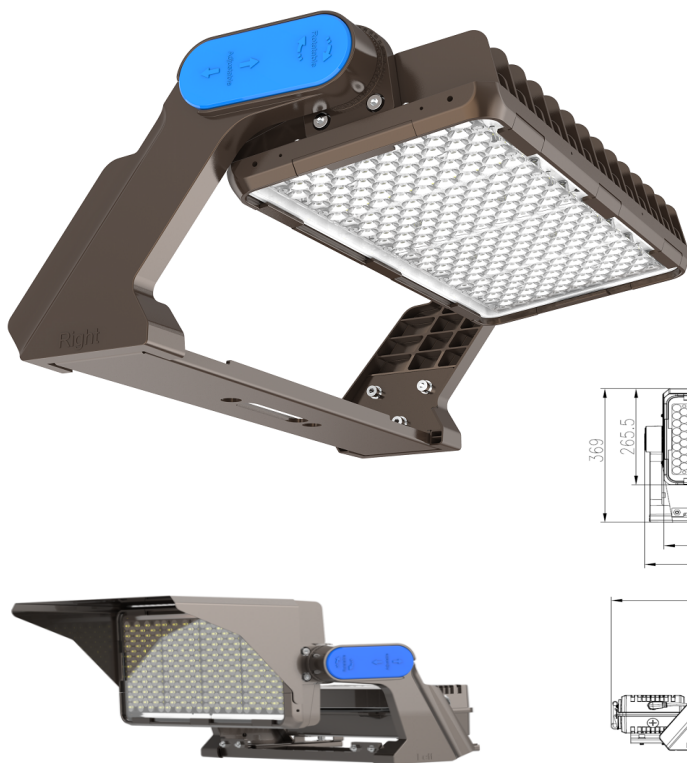

The HF2 Series LED floodlights cater to a wide range of floodlighting needs including industrial, sporting and security applications. Highly adaptable to most installations, it can be easily converted to a remote driver arrangement. The HF2 Series floodlights offer multiple optics choices, effective glare control and a highly adjustable mounting bracket system, to ensure effective lighting results.

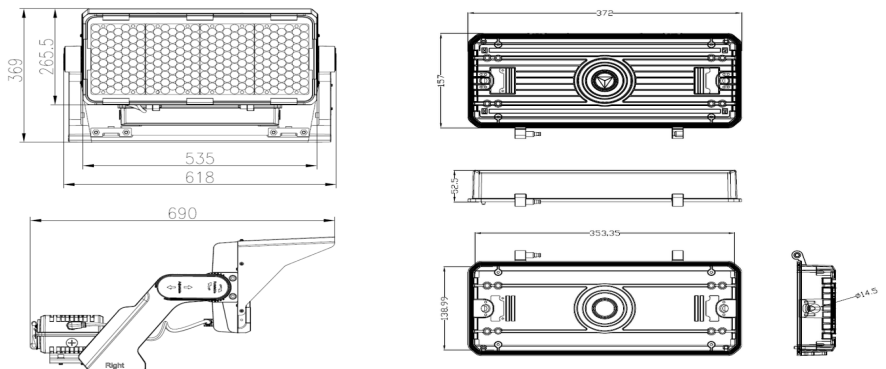

Features

- Heavy Duty Construction
- High efficiency Lumiled/Samsung chips
- Asymmetric and symmetrical optics choices
- Glare and spill light visor (symmetrical models only)
- Top & underslung crossarm mountable
- Bird protection
- 0-10V Dimming

Applications

- Sports Lighting
- Hard Stands
- Industrial Sites
- Security Lighting
- Signage

Standard Specifications

- Rated Input Power: 600W
- Input Voltage: AC 100 - 277V
- IP Rating: IP66
- Lumen Output: 81,000lm
- Colour Temp: 5000K (4000K, 5700K Optional)
- Service Life: L70 >50,000hrs / L90B10 >42,000hrs
- EPA (Sail Area): 0.103m² @ 70deg (no visor)
- EPA (Sail Area): 0.219m² @ 70deg (inc visor)
- Fitting Weight: 14.9kg (without driver)
- Driver weight: 5.2kg (inc driver box)

Options List

- Remote Driver/REM
- 415Vac Driver/415V

Models List

Bronze / 60x60 deg	HF2600BR5KD01	Special Order
Bronze / 30x30 deg	HF2600BR5KD02	Special Order
Bronze / 10x10 deg	HF2600BR5KD03	Special Order
Bronze / 120x120 deg	HF2600BR5KD04	Special Order
Bronze / NB ASYM	HF2600BR5KD05	Special Order
Bronze / MB ASYM	HF2600BR5KD06	Special Order
Bronze / WB ASYM	HF2600BR5KD07	Stock Item

Accessories

15m DC Extension cable	HF2DCEXT15M
20m DC Extension cable	HF2DCEXT20M
25m DC Extension cable	HF2DCEXT25M

IES Files

1300 551 942

sales@integratedpower.net.au



 **Integrated**
POWER

* For full warranty terms and conditions visit www.integratedpower.net.au

Date : 25-2-2022