

HBM Series 2

LED HIGHBAY POWER & 2CCT SELECTABLE
120W to 200W

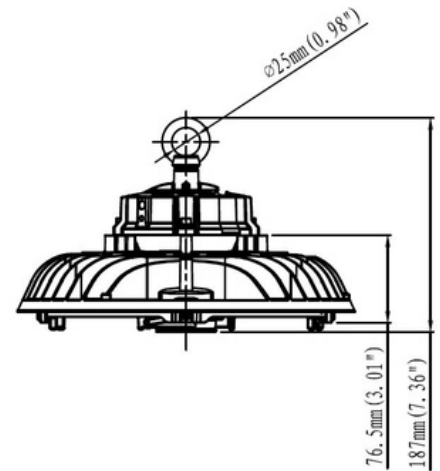

Integrated Power's HBM Series 2 LED highbays are the latest edition to the highbay range. Designed with power, colour and beam angle selections as a standard feature, gives you 18 different options in 1 model. The HBM highbay can be adjusted from 200W down to 120W with wide, medium and narrow beam angles to suit most warehouse lighting requirements.

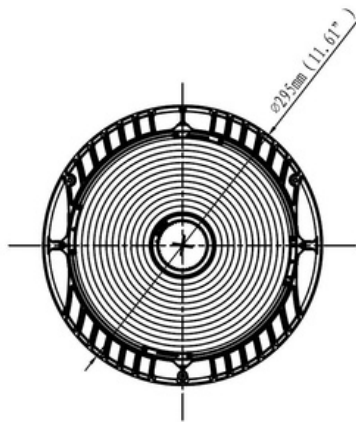

Features

- High output 150lm/W LED chips
- Power selectable driver
- High lumen efficiency
- Adjustable lens (Wide/Medium/Narrow)
- 2CCT Selectable
- 1.5m cable with Australian plug
- Carabiner clip included
- Motion Sensor option

Applications

- Warehouses
- Factories
- Gymsnasiums
- Workshops



Standard Specifications

- Rated Input Power: 200W - 160W - 120W
- Lumen Output: 36,000lm @ 200W
- Colour Temperature: 4000K /5000K
- SDCM Rating: < 5
- CRI Rating: CRI>80
- Beam Angle: 105°/85°/60°
- IK Rating: IK08
- IP Rating: IP65
- Operating Temp: -30°C to 50°C
- Service Life: >83,000hrs (25°C@L80)
- Fitting Weight: 2.6kg (±0.3kg)

Option List

- DALI Dimming /DALI

Models List

200W / 2CCT Selectable

HBM2200BKXKD01

Accessories

Polycarbonate Diffuser Kit	HBM2DK01
Adjustable Tilt Bracket	HBM2BL01
Microwave Motion Sensor	HBM2MS01
Motion Sensor Remote	HBM2MSR01

IES Files

IES HBM2200BK5KD01 105 Deg - 200W
IES HBM2200BK5KD01 85 Deg - 200W
IES HBM2200BK5KD01 60 Deg - 200W

