

CFM Series

MARINE GRADE LED FLOODLIGHT - 50W

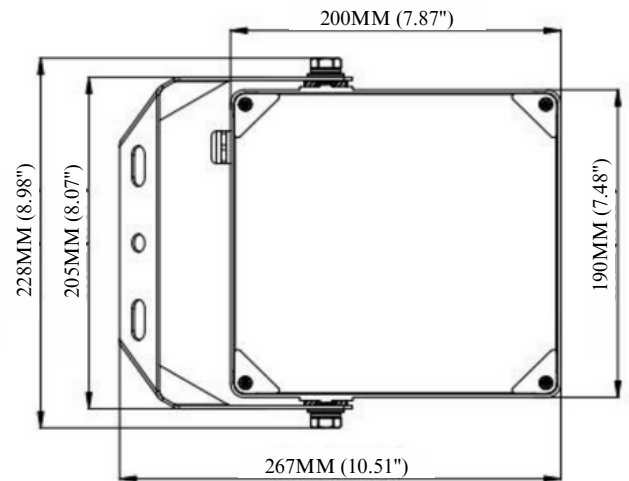

The CFM Series LED floodlights are the latest edition to Integrated Power's commercial floodlight range. Built with an anti-corrosive protective coating to withstand harsh environmental conditions. Includes a stainless steel bracket with a heavy duty housing.

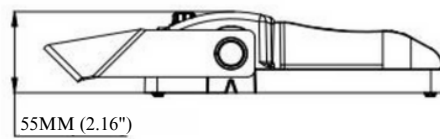
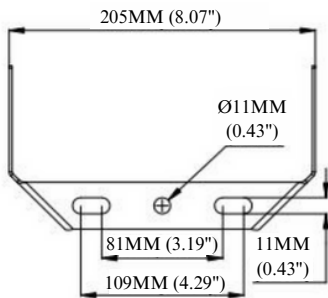

Features

- Heavy Duty Construction
- Anti-corrosion protective coating
- ZAM coated bracket
- High lumen output
- Symmetric/Asymmetric optics available
- Dimmable: No (0-10V optional)

Applications

- Ports
- Transportation
- Industrial sites
- Marine
- Coastal areas



Standard Specifications

- Rated Input Power: 50W
- Lumen Output: 6,500lm
- Colour Temperature: 5000K (3000K, 4000K optional)
- CRI Rating: CRI>80
- SDCM Rating: < 5
- Beam Angle: Symmetric/Asymmetric
- Operating Temperature: -30/+50°C
- Service Life: L70 > 63,000hrs
- IP Rating: IP66
- IK Rating: IK08
- Weight: 1.8kg

Option List

Models List

5000K / Asymmetric Optic

CFM50SI5KN01

5000K / Symmetric Optic

CFM50SI5KN02

Accessories

Pole Bracket Adaptor - 60mm

CFPBR01

Pole Clamp Bracket 40-150mm

CFCL150B

IES Files

IES CFM50SI5KN01 50W ASYM

IES CFM50SI5KN02 50W SYM

