

IMPORTANT INSTRUCTIONS AND OPERATING MANUAL

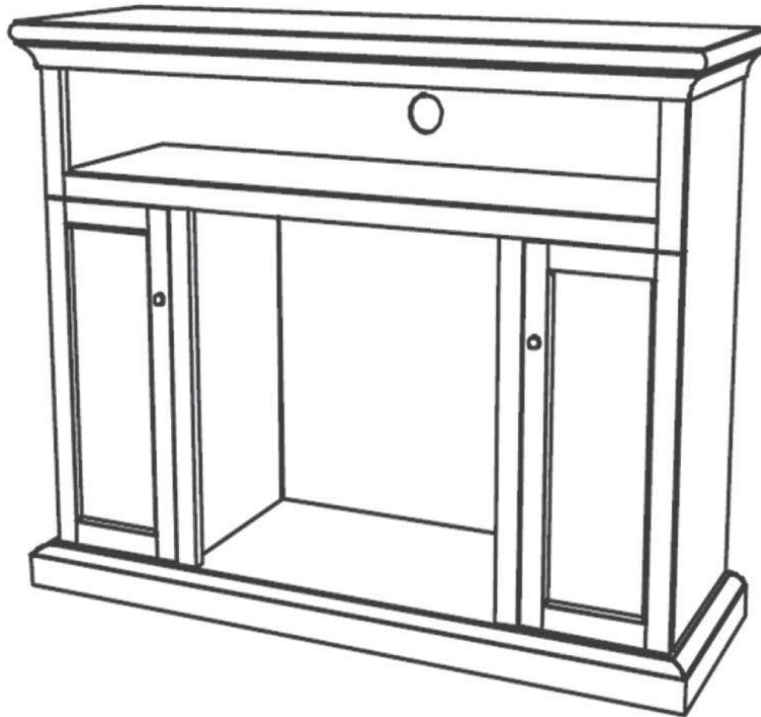

ZBI-15SRLT/M21 ELECTRIC HEATER

THIS INSTRUCTION BOOKLET CONTAINS IMPORTANT SAFETY INFORMATION. PLEASE READ AND KEEP FOR FUTURE REFERENCE.

Do Not Return This Product!

Contact our customer service team for help first.

Call: 213-4467172

Or 661-4358826

Monday - Sunday 8:30 am - 5:30 pm P.S.T

ROWAN ELECTRIC APPLIANCE LLC 28407 Ascent
Way, Santa Clarita, CA 91350



WARNING

- Unit can tip over causing severe injury or death.
- Anchor unit to stud in wall (if instructed to).
- Do Not allow children to climb on unit.
- Put heavy items on lower shelves or drawers.



CERTIFIED UNDER CANADIAN AND
AMERICAN NATIONAL STANDARDS: ETL



Contact Us !

DO NOT RETURN THIS PRODUCT!

Contact our friendly customer service team first for help.

Call: 213-4467172

Or 661-4358826

(8:30 am - 5:30 pm P.S.T)

DATED PROOF OF PURCHASE IS REQUIRED FOR WARRANTY SERVICE.

[Helpful Hints]

PEOPLE NEEDED FOR ASSEMBLY: 1-2
ESTIMATED ASSEMBLY TIME: 1 HOUR

-Open your item in the area you plan to keep it to avoid excessive heavy lifting.



-Identify, sort and count the parts before attempting assembly.



-Make sure to always face the point on the top of the Cam Lock towards the outer edge.



-Use all the nails provided for the back panel and spread them out equally.



-Back panel must be used to make sure your unit is sturdy.





-Do NOT use harsh chemical or abrasive cleaner on this item.

-Never push, pull, or drag your furniture.



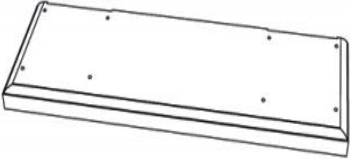
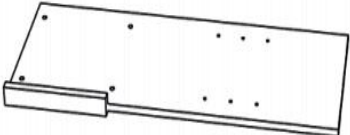
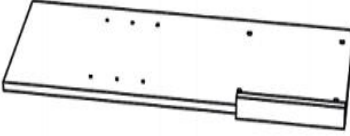
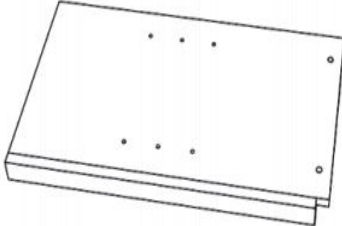
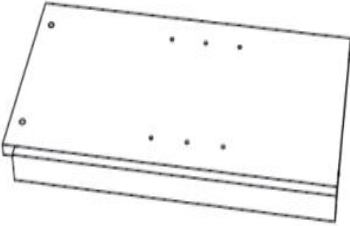

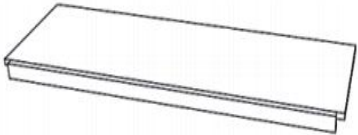
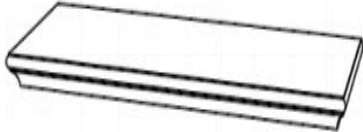
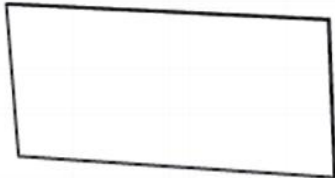

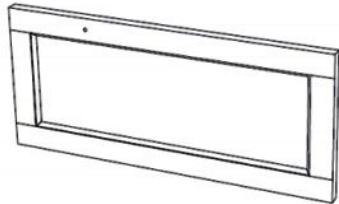
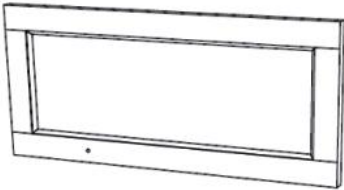
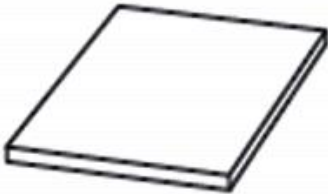







Parts List

Label	Picture	Description	QTY
A		Base	1
B		Left Side Panel	1
C		Right Side Panel	1
D		Left Partition Wall	1
E		Right Partition Wall	1

F		Long Shelf	1
G		Top Panel	1
H		Back Panel	2
I		Upper Back Panel	1
J		Left Door	1
K		Right Door	1
L		Shelf	2

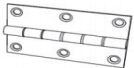
Hardware

Label	Picture	Description	QTY
1		Corner Bracket	8
2		Bolt(M6X12)	16
3		Bolt(M6X30)	12
4		Washer	12
5		Allen Key	1
6		Screw(3*12)	28
7		Screw(3*16)	4
8		Screw(ST4.2*12)	4
9		Shelf Support	8
10		Door Knob	2
11		Bolt(for Door Knob)	2
12		Hinge	4
13		Magnet Door Support	2
14		Magnetic Plate	2

Assembly Preparation

Parts Introduction

Before
Beginning
Assembly

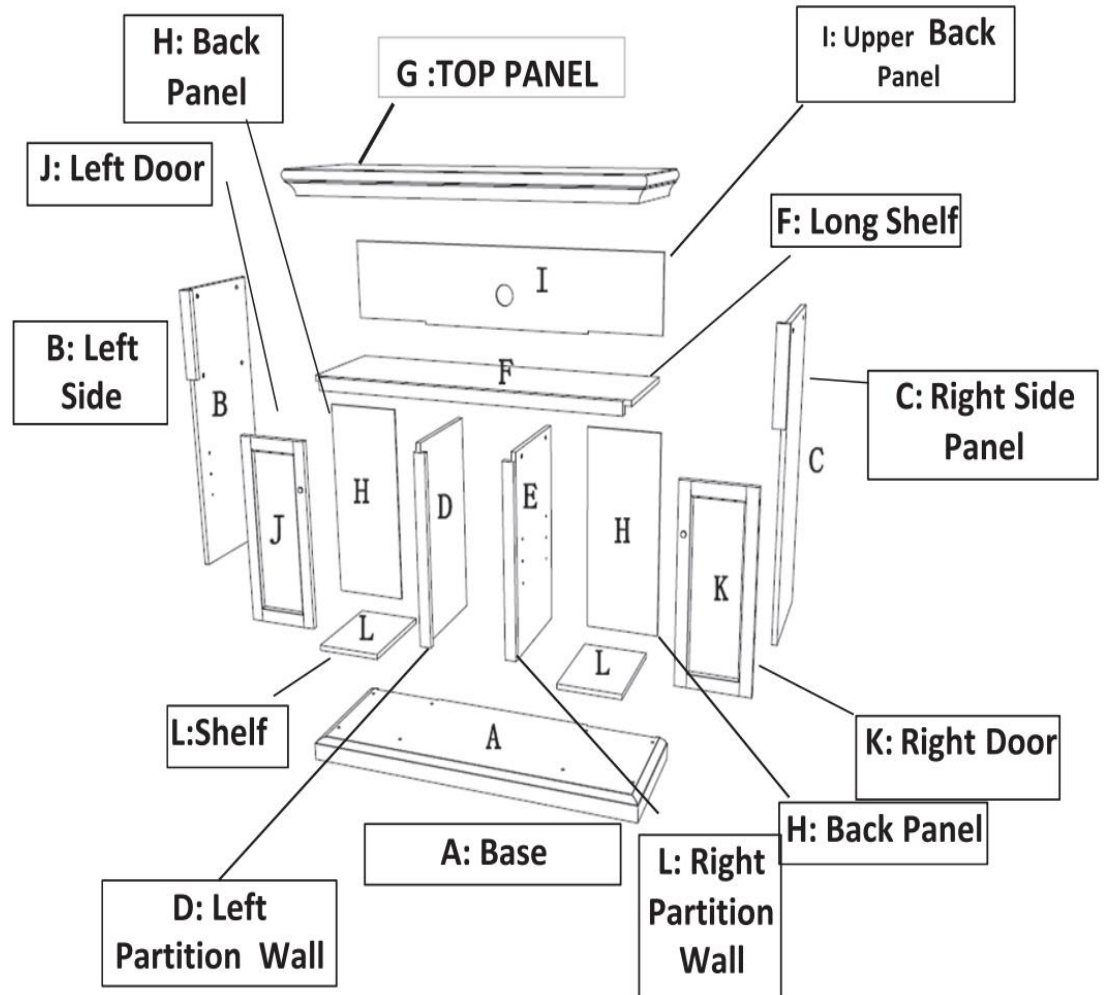

- Read instructions, cover to cover-



- Have 2 adults on hand for assembly-



- Do not assembly on flooring or carpet-



- Assembly on a clean non-marring surface (packing foam) -



- Save all packaging until finished-

Assembly Steps

Step 1

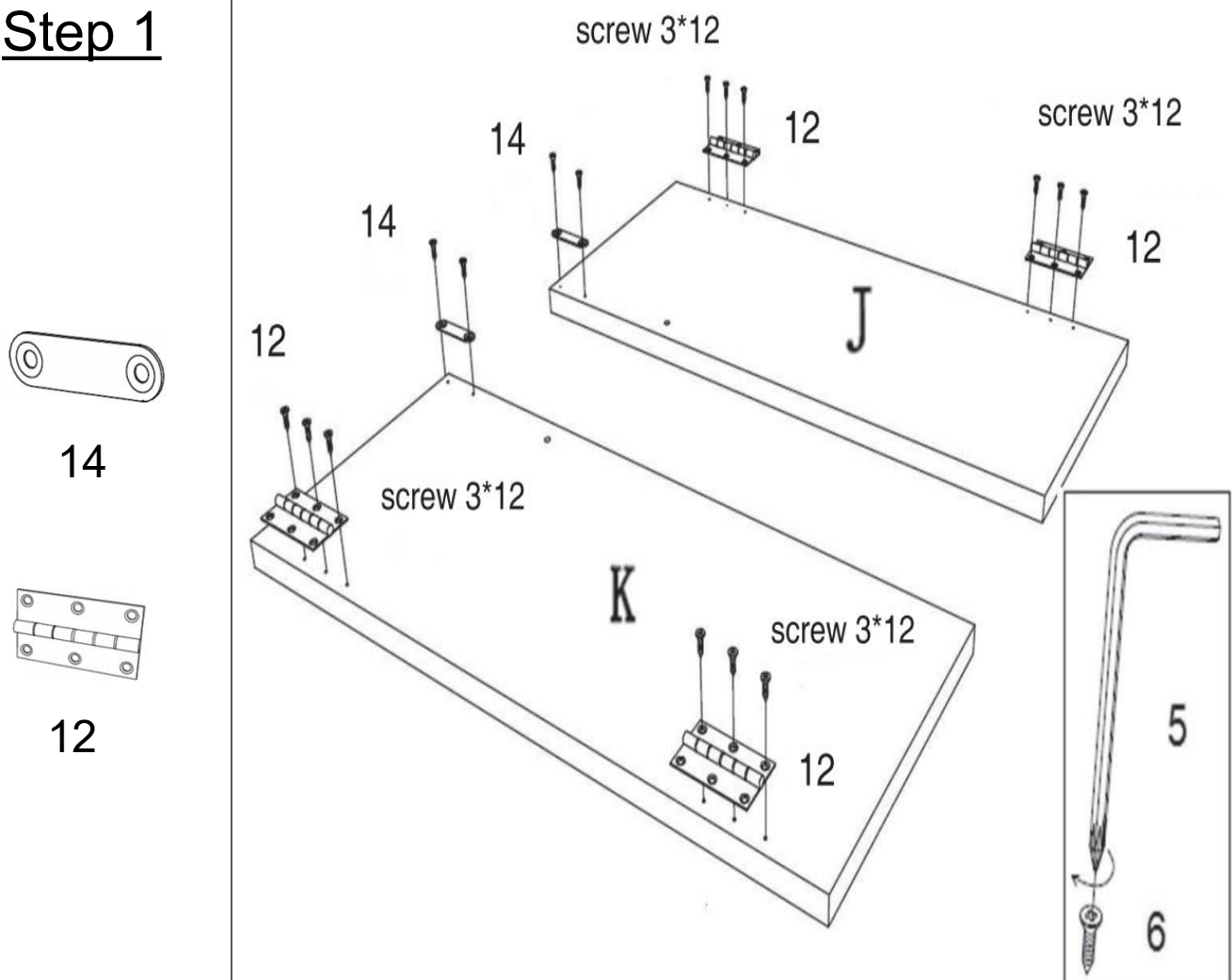

Open up the carton and take out all Parts and place them on a clean, non-marring surface. Then, open the hardware pack.

Attach Hinges(12) to Right Door(K) using Screws(6) with Allen Key(5) as shown in the picture. Attach the **Magnetic Plate(14)** to the Right Door(K) using Screws(6) with Allen Key(5) as pictured above.

Repeat the same process with Left Door(J).

Only Loosely tighten the Screws.

Step 2



13

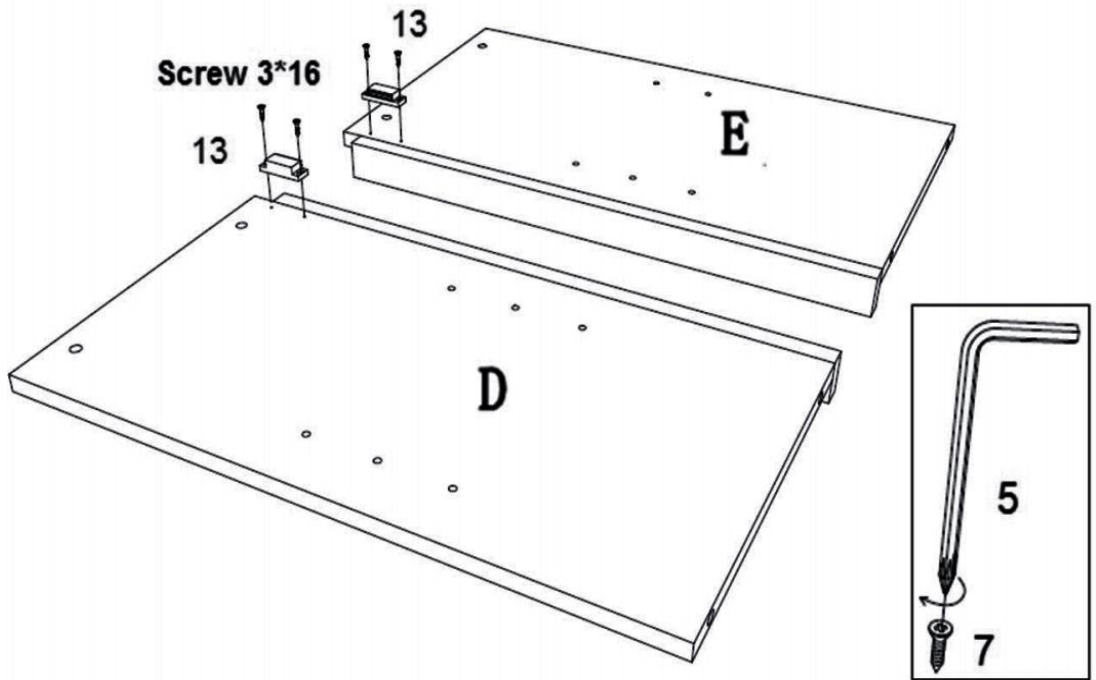

Attach Magnet Door Stopper(13) to Left Partition Wall(D) using Screws(7) with Allen Key(5) as pictured above.

Repeat the same process with Right Partition Wall(E).

Only Loosely tighten the Screws.

Step 3

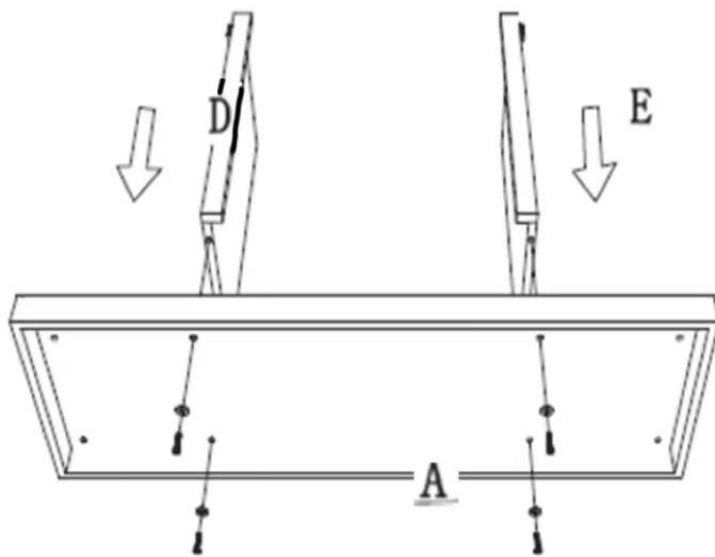

M6X30 Bolt

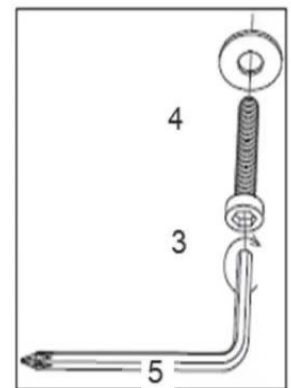

Position Left Partition Wall(D) and Base(A) at a 90-degree angle.

Attach them using Bolts(3) and Washers(4) with Allen Key(5) as shown in the picture.

Repeat the same process to connect the Base(A) with Right Partition Wall(E).

Only Loosely tighten the Screws.

Step 4

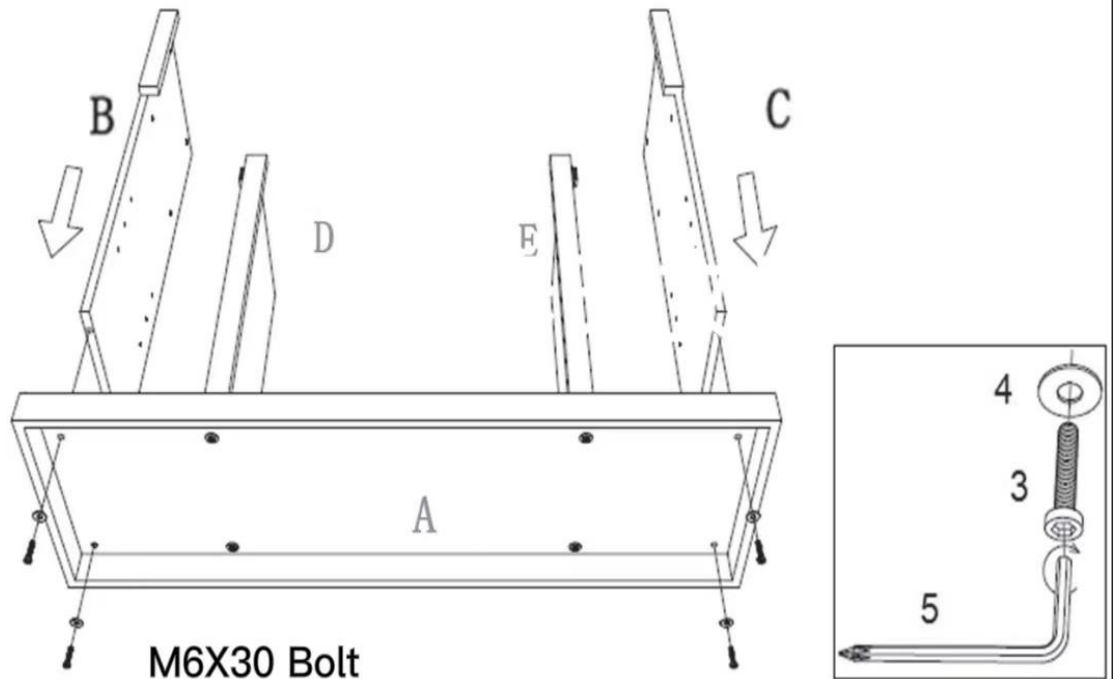

Position Left Side Panel(B) and Base(A) at a 90-degree angle.
Attach them using Bolts(3) and Washers(4) with Allen Key(5) as shown in the picture.
Repeat the same process to connect the Base(A) with Right Side Panel(C).
Only Loosely tighten the Bolts.

Step 5

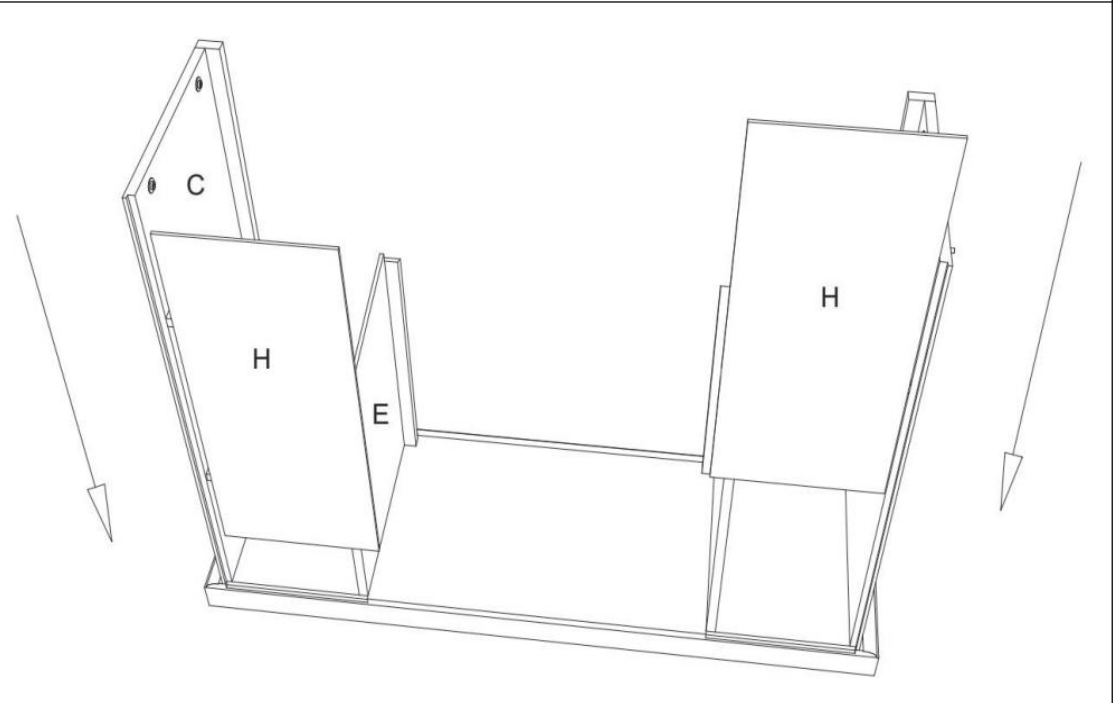

Connect Back Panel(H) with Right Side Panel(C) and Right Partition Wall(E).
Repeat the same process to install the remaining Back Panel(H) to Left Partition Wall and Left Side Panel.
Only Loosely tighten the Screws.

Step 6

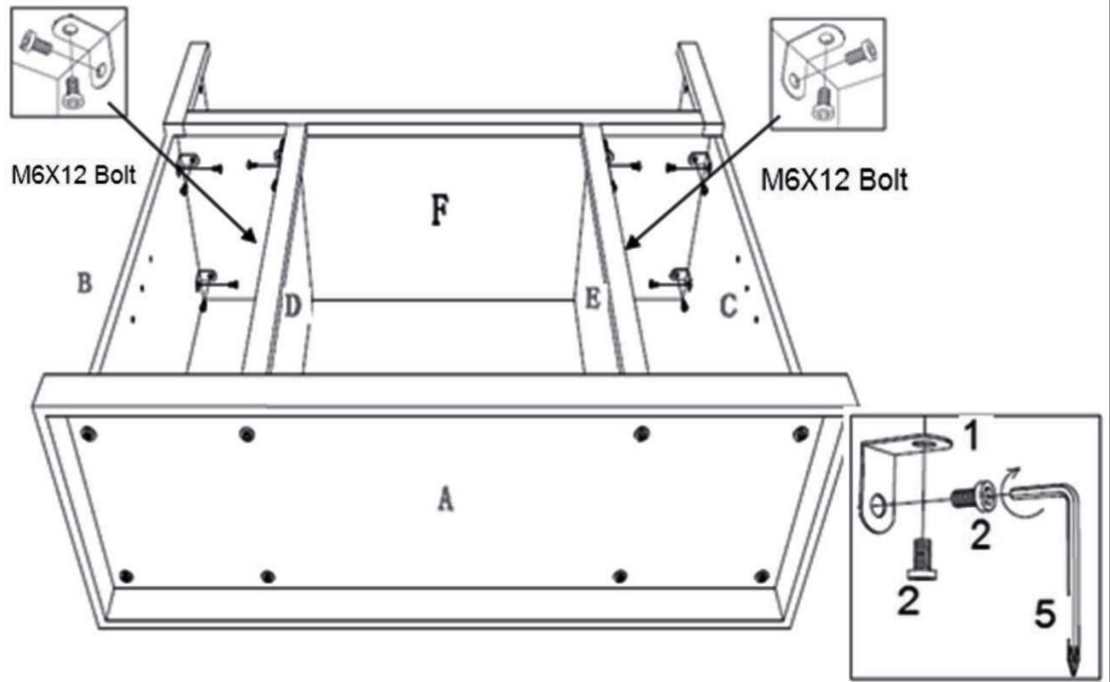

Gently place Long Shelf(F) on Left Partition Wall(D) and Right Partition Wall(E). Attach them using Corner Brackets(1) and Bolts(2) with Allen Key(5) as pictured above. **Only Loosely tighten the Bolts.**

Step 7

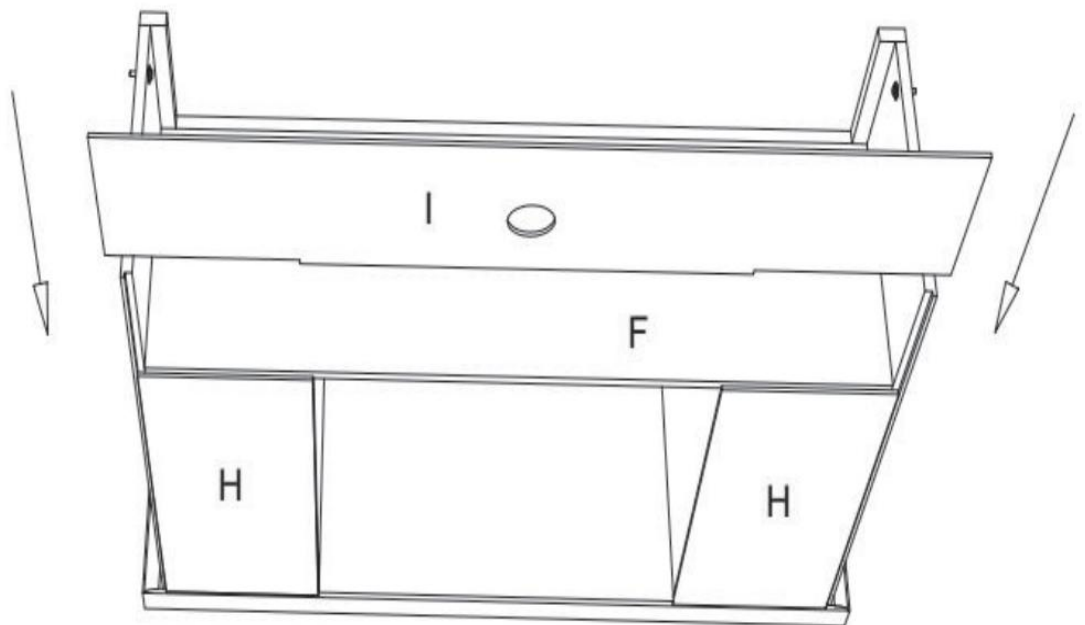

Connect the Upper Back Panel(I) with Side Panel and the Long Shelf(F). **Only Loosely tighten the Screws.**

Step 8

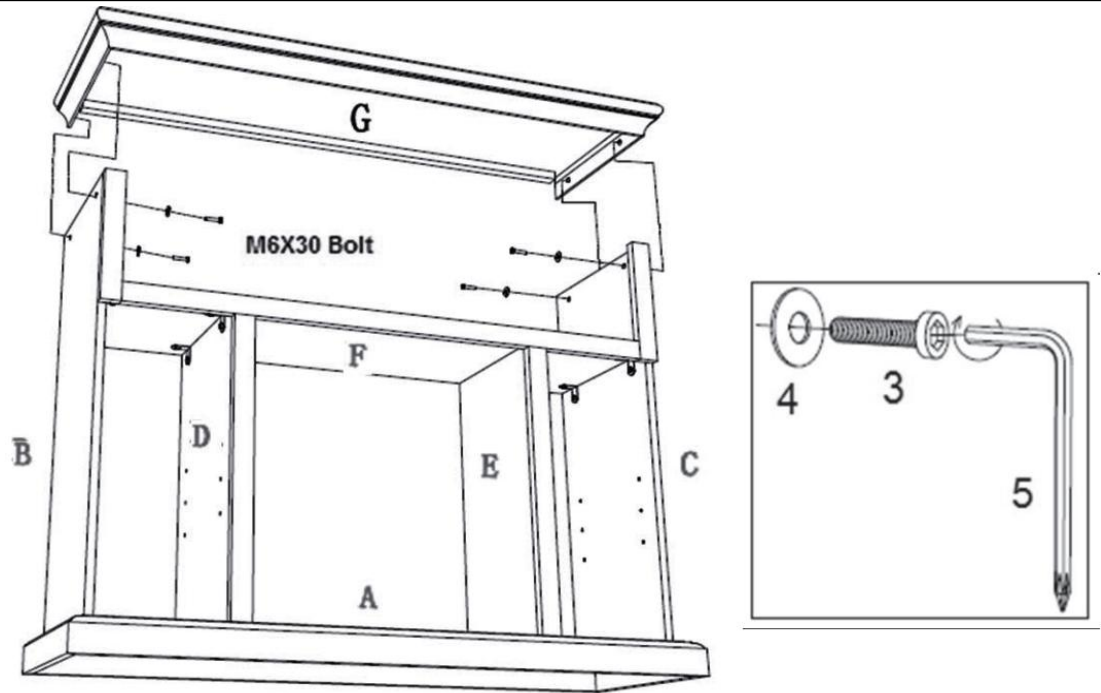

Gently place the Top Panel(G) on the top of the Mantel and attach, using Bolts(3) and Washers(4) with Allen Key(5) as shown in the picture.

Only Loosely tighten the Bolts.

Step 9

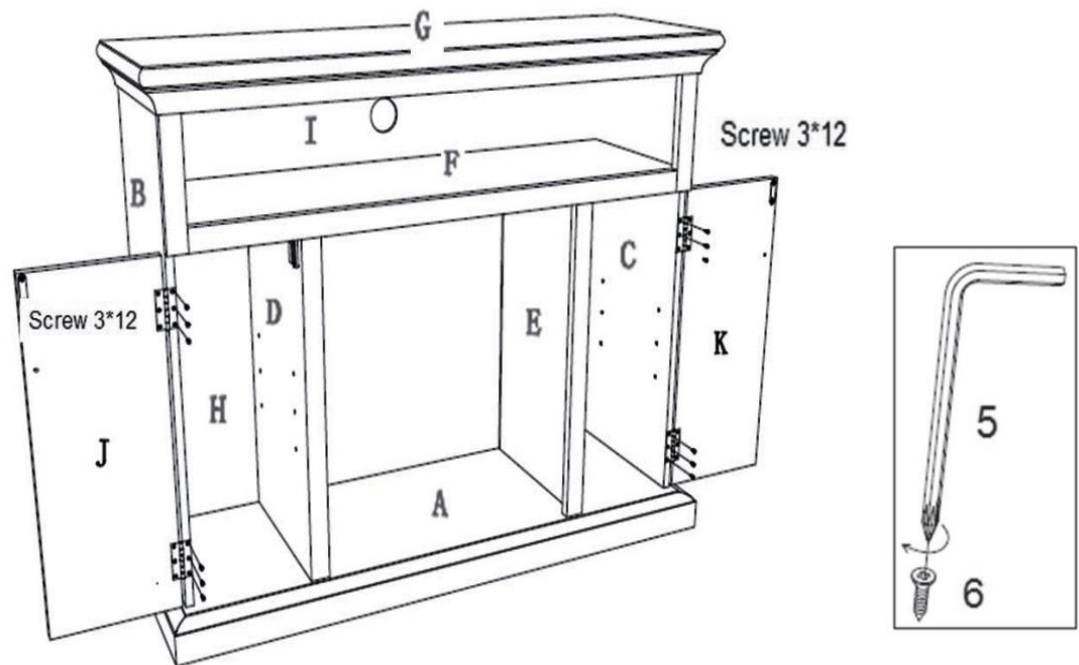

Connect the Left Door (J) to Mantel using Hinges(12) and Screws(6) with Allen Key(5) as shown in the picture.

Repeat the same process to connect the Right Door(K) to Mantel.

Now tighten all Bolts and Screws at all joints.

Step 10

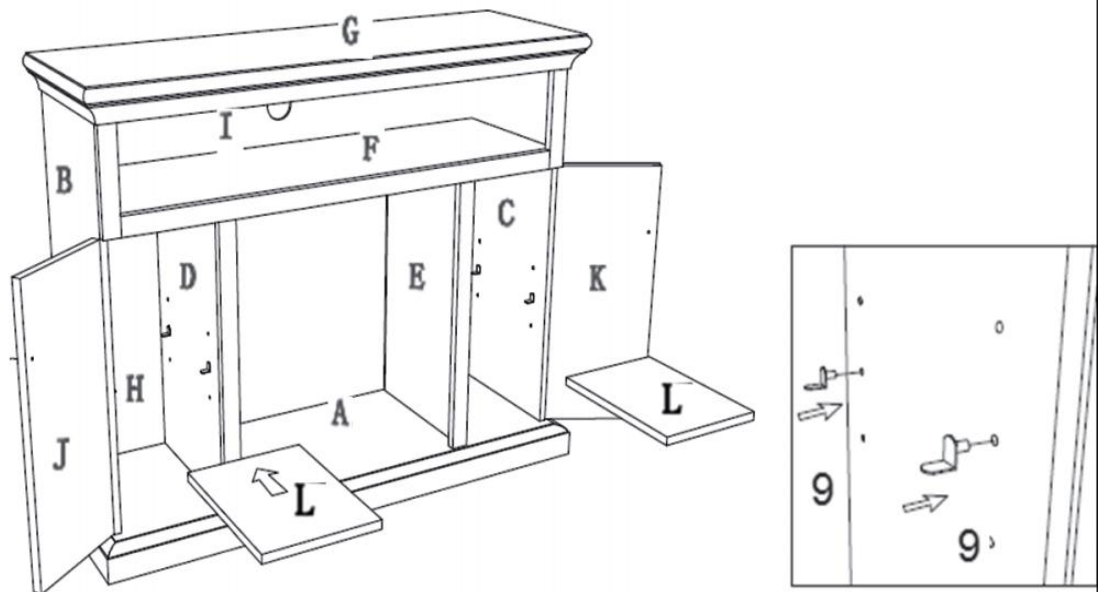

Insert the Shelf Supports(9) into the mounting positions of the Left Partition Wall(D) and Left Side Panel(B) as shown in the picture.

Note: The height of the Shelf is your preference and there are three height options.

Insert the Shelf Supports(9) into the mounting positions of the Right Partition Wall(E) and Right Side Panel(C).

Place the two Shelf Panels(L) horizontally on the Shelf Supports(9).

Step 11

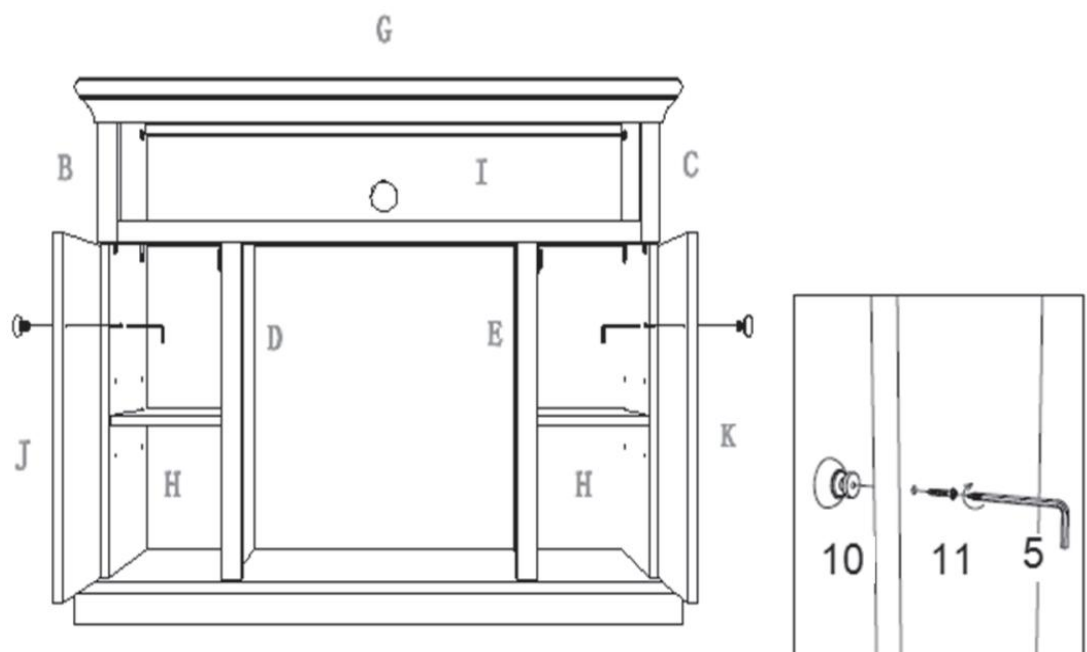

Attach Door Knob(10) to Left Door(J) using Bolts of Door Knob(11) with Allen Key(5).

Attach Door Knob(10) to Right Door(K) using Bolts of Door Knob(11) with Allen Key(5).

Step 12

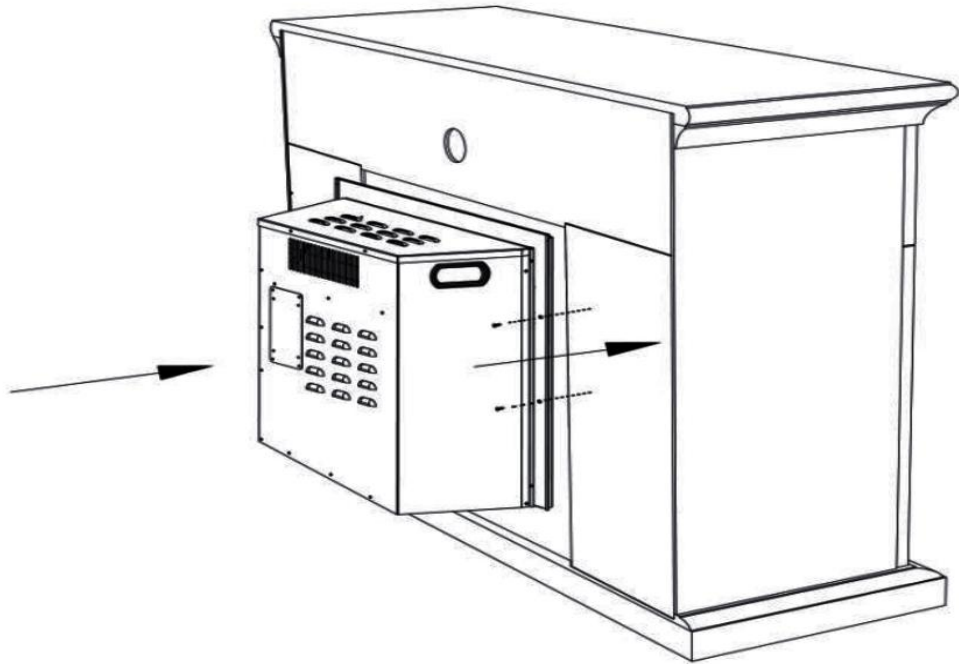

Use screw 8(ST4.2*12) to insert the Fireplace into the Mantel from the back to front.

Step 13

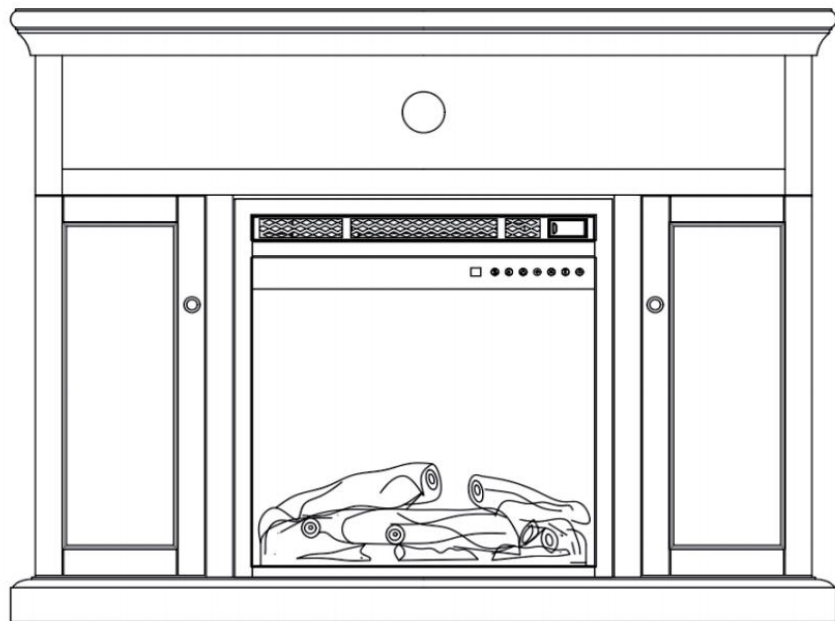

The above steps complete the assembly process of putting together the Fireplace Mantel. For the usage and operations of the Fireplace - please refer to the Operations Manual.

Care & Maintenance



- Do not put hot items directly on the furniture surface.



- Do not clean furniture with harsh cleansers or polish.

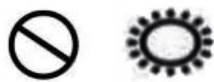

- Do not place furniture under direct sunlight.



- Do not place furniture near heating or cooling vents.



- Do not write on furniture without a padded barrier to protect the surface.



- Do not place furniture outside. For indoor use only.



- Not for commercial use. For residential use only.



- Stains can be removed with a mild soap solution damp cloth.



- Children should not climb or jump on the furniture.



- Wipe off the dust and pick up spills with a clean, non-colored, lint-free cloth.

Thank you for purchasing this product! If you have any questions about the product, such as missing parts, damaged products, product assembling, and operation, please contact us via **Amazon Message** or customer service number: **213-4467172 or 661-4358826**

IMPORTANT

Please call our customer service department for any consulting:

213-4467172

661-4358826

(8:30am - 5:30pm P.S.T.)

DATED PROOF OF PURCHASE IS REQUIRED FOR WARRANTY SERVICE.

AVIS

Veillez appeler le service à la clientèle pour toutes questions au:

213-4467172

661-4358826

(8:30am - 5:30pm P.S.T.)

PREUVE D'ACHAT ORIGINALE REQUISE POUR SERVICE DE GARANTIE.

IMPORTANTE

Sólo hay que llamar nuestro departamento de servicio al cliente en caso de tener preguntas o inquietudes:

213-4467172

661-4358826

(8:30am - 5:30pm P.S.T.)

SE REQUIERE PRUEBA DE COMPRA CON FECHA PARA SERVICIO BAJO GARANTÍA.

**Address: ROWAN ELECTRIC APPLIANCE LLC 28407 Ascent Way,
Santa Clarita, CA 91350
Phone: 213-4467172 or 661-4358826**