



**ENERMAX**  
POWER. INNOVATION. DESIGN.



ECB500AWT

ECB600AWT

ECB700EWT

# CYBERBRON



# CYBERBRON

- *80 PLUS® Bronze Certification*
- *Flexible Black Flat Cable Design*
- *Using Japanese Electrolytic Capacitors*
- *100-240VAC Auto-adjustment Input*



## Features

- **Energy Conservation**
  - 80 PLUS® certification with 88% efficiency @50% load
  - Efficient +5Vsb circuitry consume only under 1W at standby mode
  - Active PFC design with PF value up to 0.99
- **Easy Installation**
  - Flexible black flat cable design
- **Longer Product Lifespan**
  - Using Japanese electrolytic capacitors
- **Great Using Experience**
  - Equipped 120mm fan with intelligent RPM control
  - High-end components and advanced layout bring industrial performance
- **User Friendly**
  - Single rail +12V design
  - 100-240VAC auto-adjustment input for universal use
- **Safety**
  - Multiple protection circuitry is of OVP, UVP, OPP, SCP

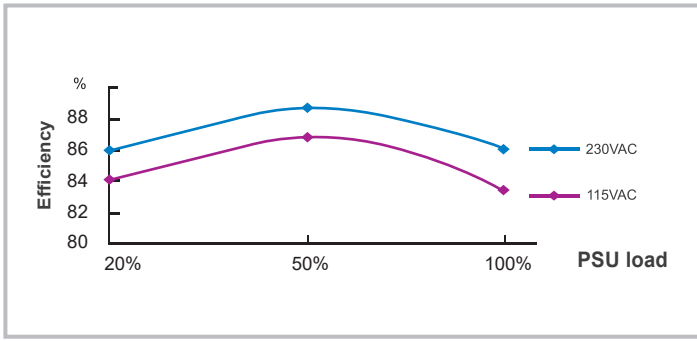

80 PLUS® Bronze Certification

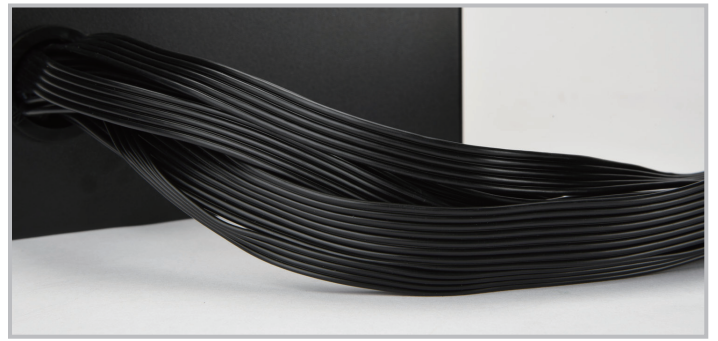

Flexible Black Flat Cable Design



Japanese Electrolytic Capacitors



120mm Fan with Intelligent RPM Control

## Dimension

Unit : mm

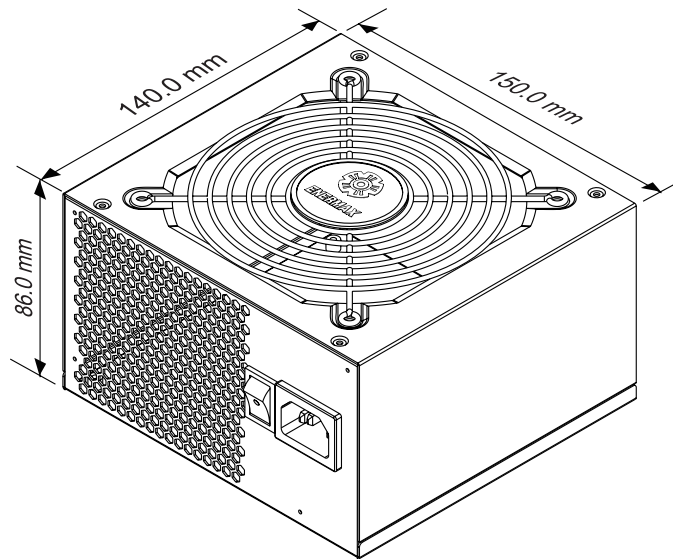

## Cables & Connectors

Model	Mainboard 24P	CPU 4+4P (8P)	PCI-E 6+2P (8P)	SATA	4P Molex	FDD (adapter)
700W	1	2	4	8	4	1
600W	1	1	2	8	4	1
500W	1	1	2	6	4	1

# Specifications

Model	ECB500AWT		ECB600AWT		ECB700EWT	
AC Input Voltage	115-230VAC, 47-63Hz		100-240VAC, 47-63Hz		100-240VAC, 47-63Hz	
AC Input Current	7A		9A		10A	
DC Output						
	Rated	Combined	Rated	Combined	Rated	Combined
+3.3V	18A	110W	19A	110W	19A	110W
+5V	17A		17A		17A	
+12V1	38A	456W	46A	552W	54A	648W
-12V	0.3A	3.6W	0.3A	3.6W	0.3A	3.6W
+5Vsb	2.5A	12.5W	2.5A	12.5W	2.5A	12.5W
Total Power	500W		600W		700W	
Dimensions	150(W) x 86(H) x 140(D)mm					
        						
Logistic Information						
Model	ECB500AWT		ECB600AWT		ECB700EWT	
Bar Code	EAN	4713157724946	4713157724953		4713157724960	
	UPC	819315024942	819315024959		819315024966	
Box Dimension	230 x 200 x 98 mm					
Gross Weight / Unit	1.94kgs		2.1kgs		2.2kgs	
Carton Dimension	428 x 418 x 255 mm					
Q'ty / Carton	8 pcs					
Gross Weight / Carton	16.4kgs		17.7kgs		18.5kgs	