

D

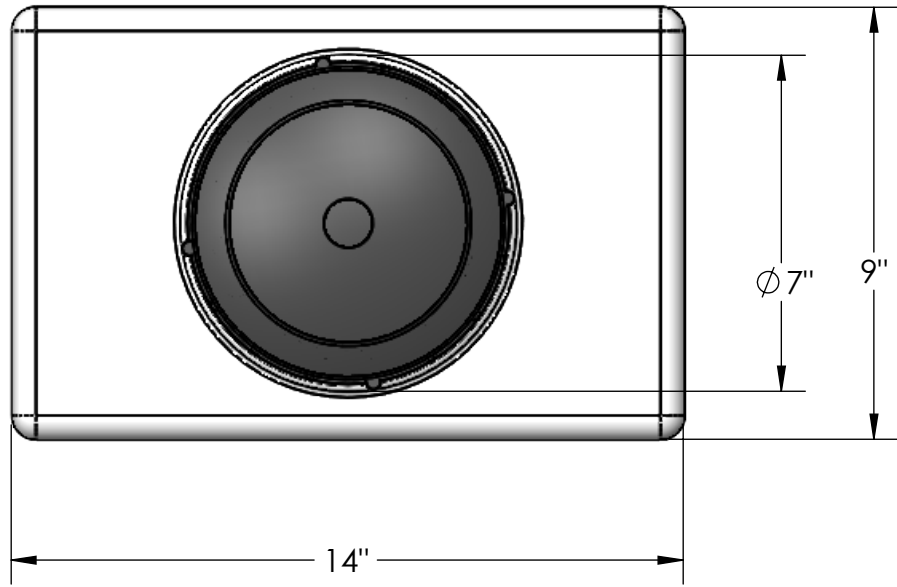

$\phi 7''$

9''

14''

D

C

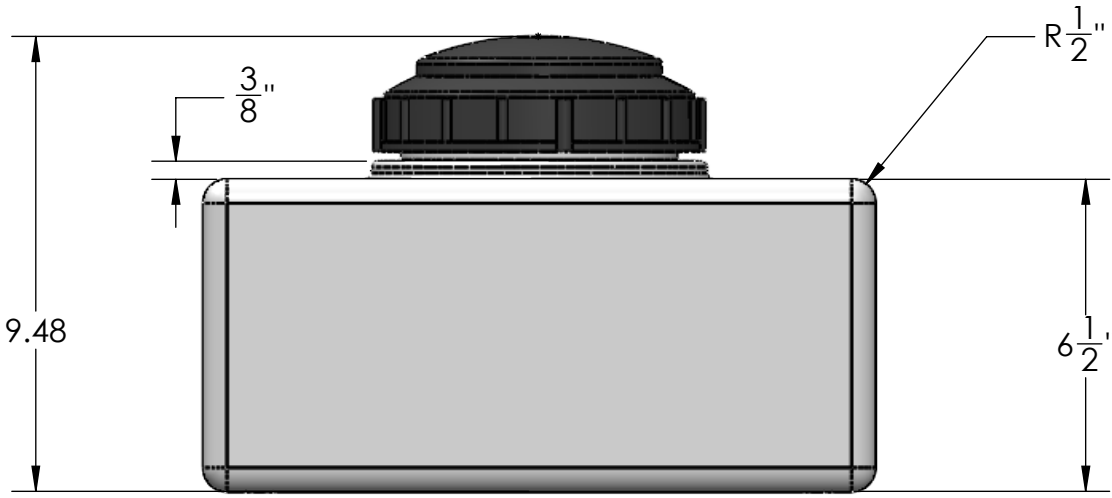

9.48

$\frac{3}{8}''$

R $\frac{1}{2}''$

$6\frac{1}{2}''$

5" THREADED CAP WITH VENT.



C

B

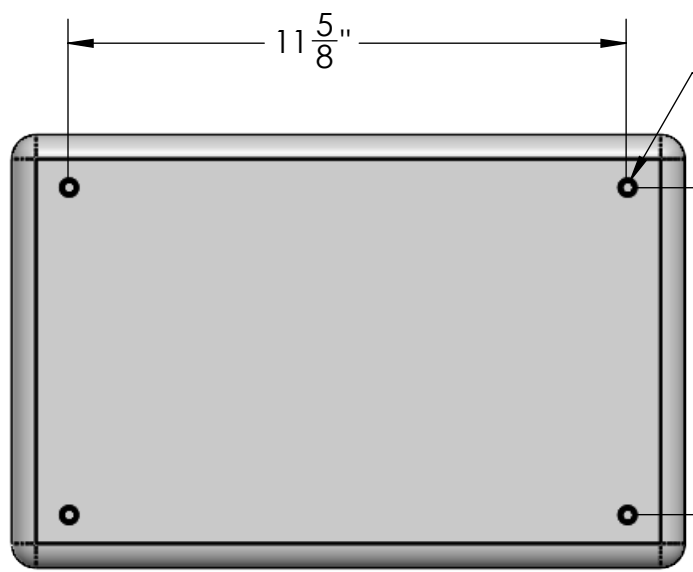

$11\frac{5}{8}''$

5/16-18 ALUMINUM INSERT (4) PLCS.

$6\frac{13}{16}''$

B

A

PROPRIETARY AND CONFIDENTIAL
 THE INFORMATION CONTAINED IN THIS DRAWING IS THE SOLE PROPERTY OF <INSERT COMPANY NAME HERE>. ANY REPRODUCTION IN PART OR AS A WHOLE WITHOUT THE WRITTEN PERMISSION OF <INSERT COMPANY NAME HERE> IS PROHIBITED.

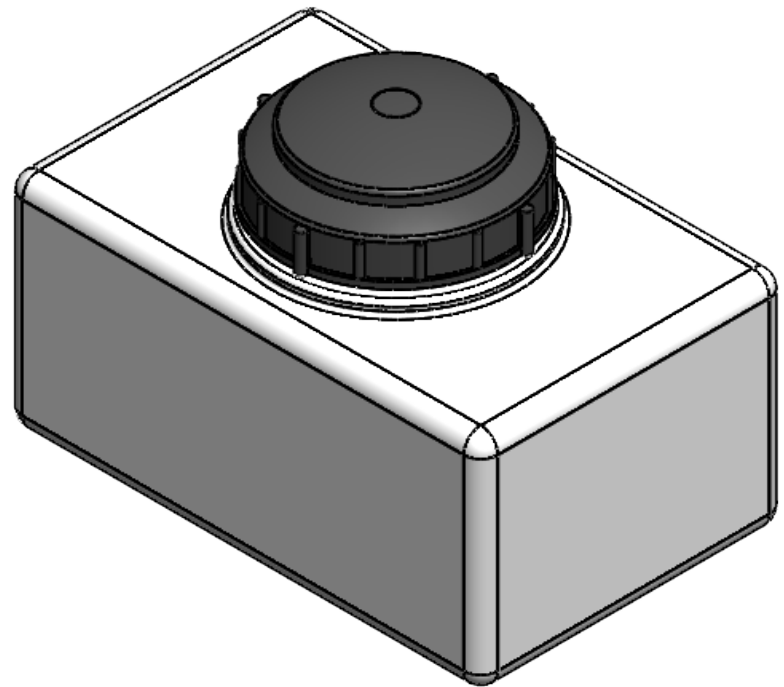

- NOTES:
 1, MATERIAL: NAT. POLYETHYLENE
 2. AVG. WALL THICKNESS: .2
 3. MOLDED WT. 3 LBS.

		UNLESS OTHERWISE SPECIFIED:		NAME	DATE		
		DIMENSIONS ARE IN INCHES		DRAWN	EBW		9/27/22
		TOLERANCES:		CHECKED			
		FRACTIONAL ±		ENG APPR.			
		ANGULAR: MACH ± BEND ±		MFG APPR.			
		TWO PLACE DECIMAL ±		Q.A.			
		THREE PLACE DECIMAL ±		COMMENTS:			
		INTERPRET GEOMETRIC TOLERANCING PER:		TITLE:			
		MATERIAL		3 GALLON RECTANGULAR TANK			
		FINISH		SIZE	DWG. NO.	REV	
NEXT ASSY	USED ON	DO NOT SCALE DRAWING		B	3 RT		
APPLICATION				SCALE: 1:4	WEIGHT:	SHEET 1 OF 1	