



# CCS704WHD

High Definition Commercial  
Wireless Monitor and Camera System

## INSTALLATION & OPERATING MANUAL



## **Product Overview**

The CCS704WHD represents a combination of the highest quality camera and LCD components, combined with the most advance digital wireless communication technology available.

The system operates at 2.4GHz. It uses Coded Differential Orthogonal Frequency Division Multiplexing (CDOFDM) technology to provide the highest quality, most secure, most reliable wireless signal available.

The camera and LCD are paired together and the image from the camera can only be received on the paired monitor.

The system is suitable for virtually all automotive applications including passenger, commercial and agricultural applications.

## **Features and Specification**

- 7" IPS-LCD color monitor with HD 1280 x 720P high resolution display
- Expandable 4/2/1 channel camera input
- wireless range of up to 400m transmission distance (line of sight)
- Automatic pairing function of monitor & camera(s)
- Night-vision function (6pcs White/Bright LED)
- 7" monitor with inbuilt DVR
- SD card data storage/record
- Quad, split or single screen display
- Mirror and normal image switch available
- Adjustable parking guidelines
- Built-in microphone and sound capability
- HD720P high resolution, wide angle lens
- Firm structure: aluminum alloy housing, anti-UV surface painting (Camera)
- Waterproof: IP68 (Camera)
- Angle adjustable
- Two years' warranty

## Features & Specification

<b>LCD701WHD</b>	
Monitor size	7.0" IPS-LCD monitor
Transmission frequency	2.4GHz (digital)
Transmission resolution	High definition
Transmission delay (ave)	< 200mS
RF pairing	Auto
Changeable channel	125CH (overlapping hopping channel)
Video frame rate	25fps / 30fps
Operating voltage	DC 9V-36V
Consumption	< 5.5W
Brightness	500cdm
Mirror image	Yes (via menu select)
Speaker	Yes
Contrast / Brightness	Yes
Camera selection	1-4 (auto or manual)
Dimensions (without sunshade)	185W x 128H x 26D mm
Weight	340g
Operating temperature	-20°C+ 70°C
<b>CAM150WHD</b>	
Image device:	1/3.7" CMOS BSI 1280Hx960V pixel
Scanning system	PAL & NTSC
Video frame rate	25fps / 30fps
Operating voltage	DC 9V-36V
Consumption (IR LED on)	< 2.5W
Lens angle	130degree diagonal
Microphone	Yes
White/Bright LED	6 (10m visibility)
White/Bright LED switch control	Photo sensor automatic control
Housing	Aluminum alloy
Mechanical vibration	10G
Mounting	Permanent tilt bracket
Weight	430g
Operating temperature	-40°C to +85°C
Ingress protection	IP68

## Required Tool List

- Screwdrivers
- Marker pencil
- Drill
- Pliers
- Panel removal tool
- Soldering iron & solder
- Voltmeter
- Safety Glasses

## Supplied Parts list

- Wireless camera with power cable
- Wireless monitor with wiring harness
- Monitor stand
- Monitor sunshade
- Installation screws/clips
- Antenna rubber stoppers

## Set Antenna & Rubber Stopper

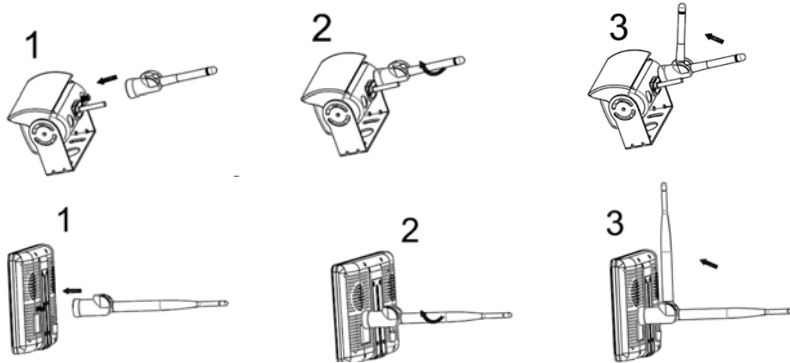

This procedure can be used for both the camera and LCD:

1. Screw antenna on the base
2. Align antenna to allow it to point straight up.
3. Adjust antenna as desired. It is recommended that antenna be aligned straight up for best reception.

## Camera Installation

The CAM150WHD Camera installation is simply a matter of bolting the camera onto the vehicle and supplying reverse power (DC 9V-36V). The only issue to take into account is mounting location. There are 3 main factors to consider:

1. Wireless Performance – The wireless communication cannot pass through metal so it is always better to try and install the camera near the top of truck or as low as possible so that the signal can effectively travel over the top or under the vehicle.
2. Viewing Angle – The primary goal of the installation is to ensure the driver has a complete view of the area behind the vehicle.
3. Protection – In harsh environments please ensure the hardware is adequately protected from bangs/knocks or the elements.

## LCD Monitor Installation

The LCD monitor requires accessory (ignition) power (DC 9V-36V). The only issue to take into account is mounting location. There are 2 main factors to consider:

1. Access and Visibility – Ensure the driver can clearly see the screen and reach the controls.
2. Antenna Location – The wireless system will perform better if the antenna is pointed upward and is above the height of the window sills – this allows the wireless signal to transmit through the window glass directly.

Choose mounting location of the LCD monitor.

Attach the surface mounting bracket to the vehicle body using the supplied mounting screws or bolts.

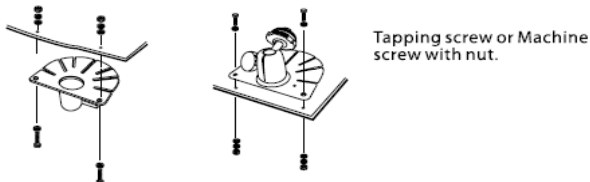

Adjust the angle of the monitor and fasten the screws firmly.

## Operation Instruction

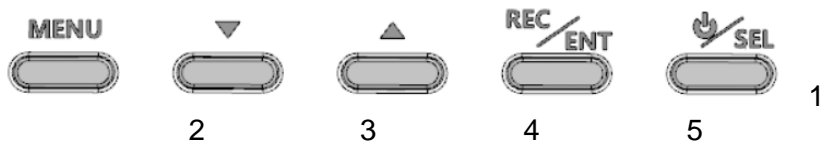
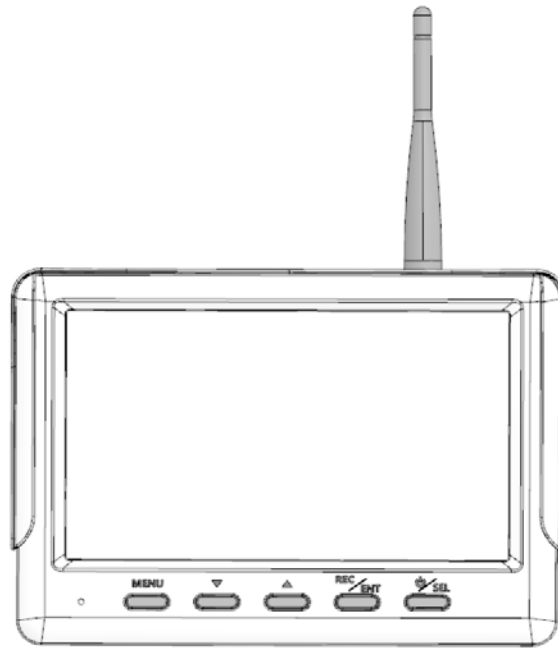

Button 1: System functionality setting MENU

Button 2: Selection/adjustment down

Button 3: Selection/adjustment up

Button 4: Record-Pause (Normal) / Setting enter (Menu)

Button 5: System power ON-OFF / CAM-CH selection

To enter the system menu interface power on the screen, press the “MENU” button and use the “▲” or “▼” button to move the cursor to the required sub menu. Press the REC / ENT button to enter the selected sub menu.

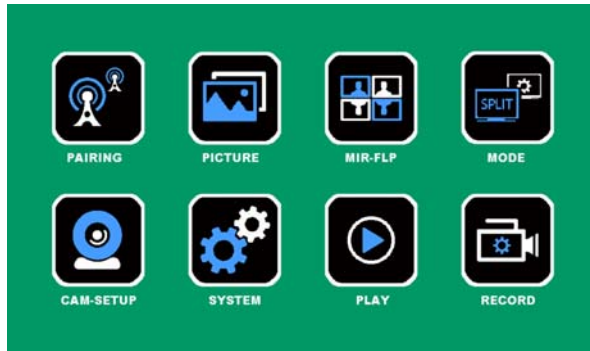

## 1. System Pairing

The purchased set will have been ‘paired’ during the assembly process so the initial operation should be as simply as power on the system monitor and camera. If for any reason the camera/ monitor combination needs to be changed then the system will need to be paired again, the pairing process is as follows:

- a) Using the CAM-CH button select the CAM-CH input to be paired e.g. CAM1. Confirming the camera is powered off select the “PAIRING” icon to enter pairing mode. During the visible countdown of 20 seconds, power on the camera. The system will automatically pair and be displayed. This system can expand up to 4 cameras, requiring individual pairing. Repeat the above procedure to pair additional cameras.

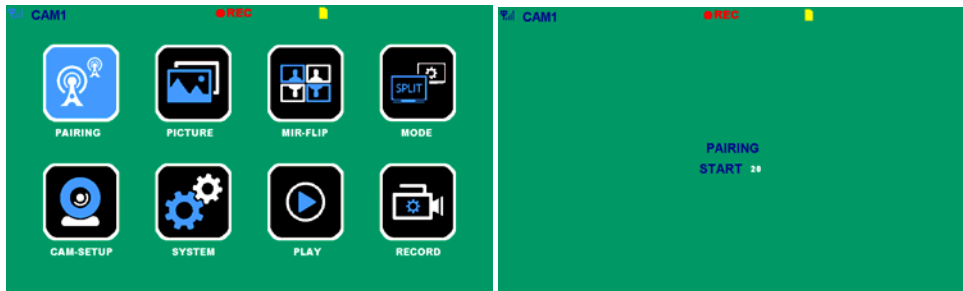

- b) Once the system is paired then it will remain paired (with or without power) until the pairing process is done again.

## 2. Picture setting

Select the "PICTURE" icon to enter the sub-menu setting interface as shown, then select and adjust the brightness, contrast, saturation and guideline feature.

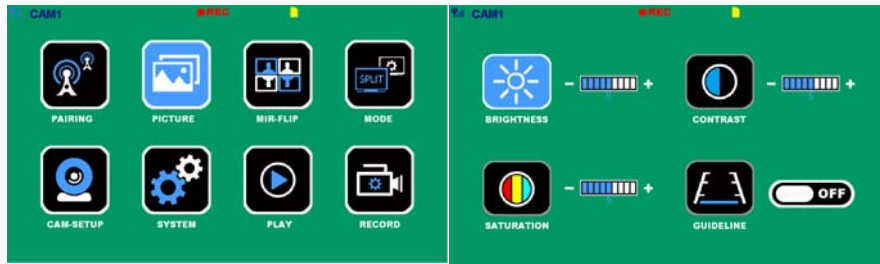

## 3. Mirror-FLP

Select the "MIR-FLP" icon to enter the sub-menu setting interface as shown, choose and select the correct mode. When used as a backup camera the image is MIRRORRED, this is the default configuration. If the camera is not used for reversing, then the imager must be switched to NORMAL mode.

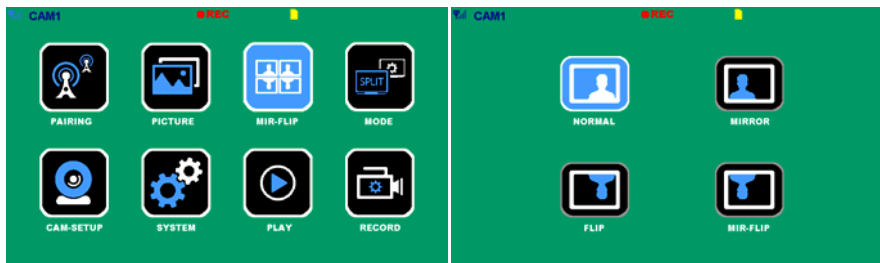

## 4. Display mode

Select the "MODE" icon to enter the sub-menu setting interface as shown, choose and select the required display mode combination.

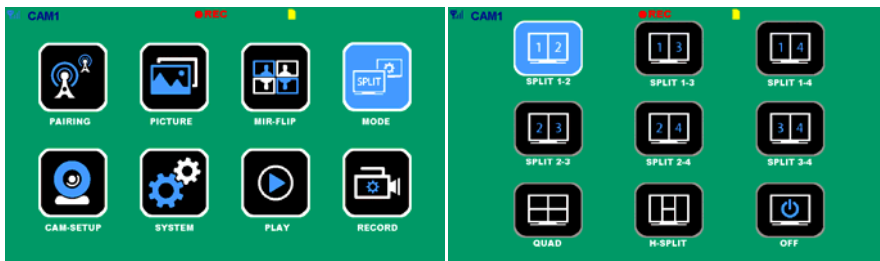



## 5. CAMERA SETUP

Select the "CAM-SETUP" to enter the sub-menu setting interface as shown. Choose and select the 4 cameras' ON-OFF status, scan time and auto scan. The auto scan feature will continuously loop the picture display of multiply cameras. The cycling time interval displays can be adjusted using the scan time feature.

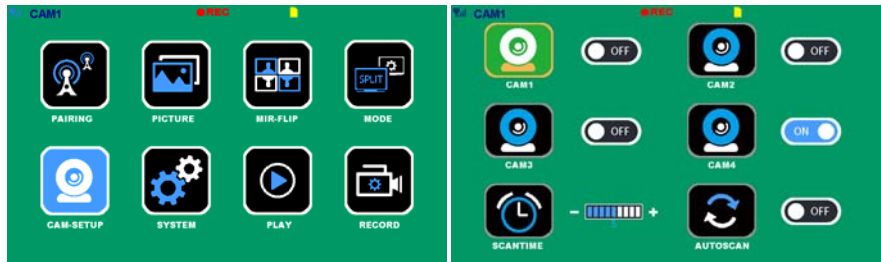

## 6. System

Select the "SYSTEM" icon to enter the sub-menu settings interface as shown. Adjust the time/date, language, color system, auto dim, delay time and volume settings.

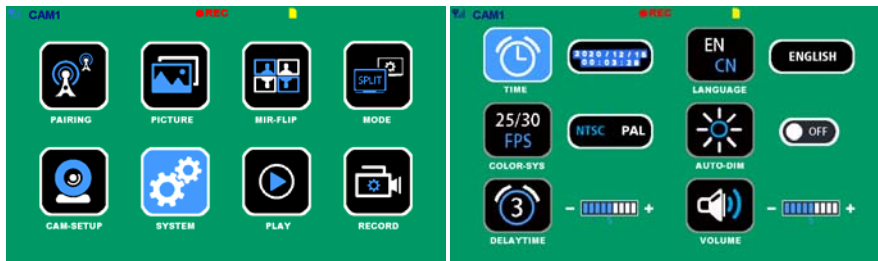

## 7. Play

Select the "PLAY" icon to enter the playback interface. Select the dated folder to playback the recorded SD card (not supplied) content. This feature will not function unless an SD card (not supplied) is inserted.

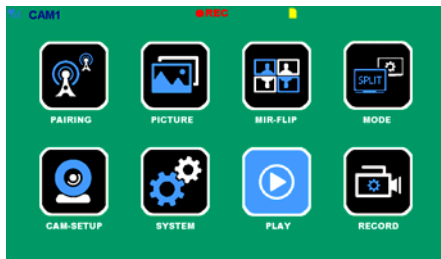

## 8. Record

Select the "RECORD" icon to enter the sub-menu setting interface as shown. Choose and select the rewrite and format settings. The initial use of a new SD card (not supplied) must be formatted prior to using the record feature. To use the record feature, select the CAM-CH to be recorded e.g. CAM1 or for multiply CAM recording select the CAM-CH display mode combination e.g. CAM1/CAM2. When the displayed CAM-CH is shown on monitor press the REC / ENT button to start recording (note the ● REC icon on top of screen). Press the REC / ENT button again to pause recording. Note: the record feature will not record if the monitor is powered off.

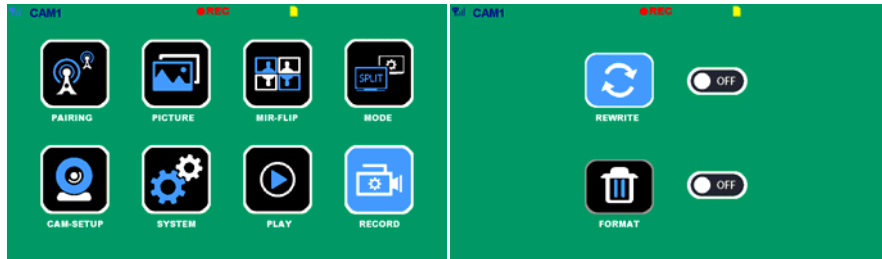

## Trouble Shooting

If for any reason the system does not function, firstly confirm that both the camera and monitor have power (check fuses of power cables). Note the monitor screen has a small blue power activation light on the front.

If the communication is too weak to send an image you will see:

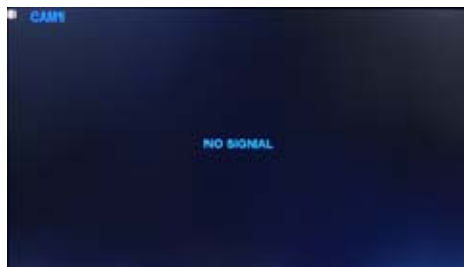

In each instance follow the pairing guide with the camera and monitor in line of sight (or as close together as possible).

# Wiring Diagram

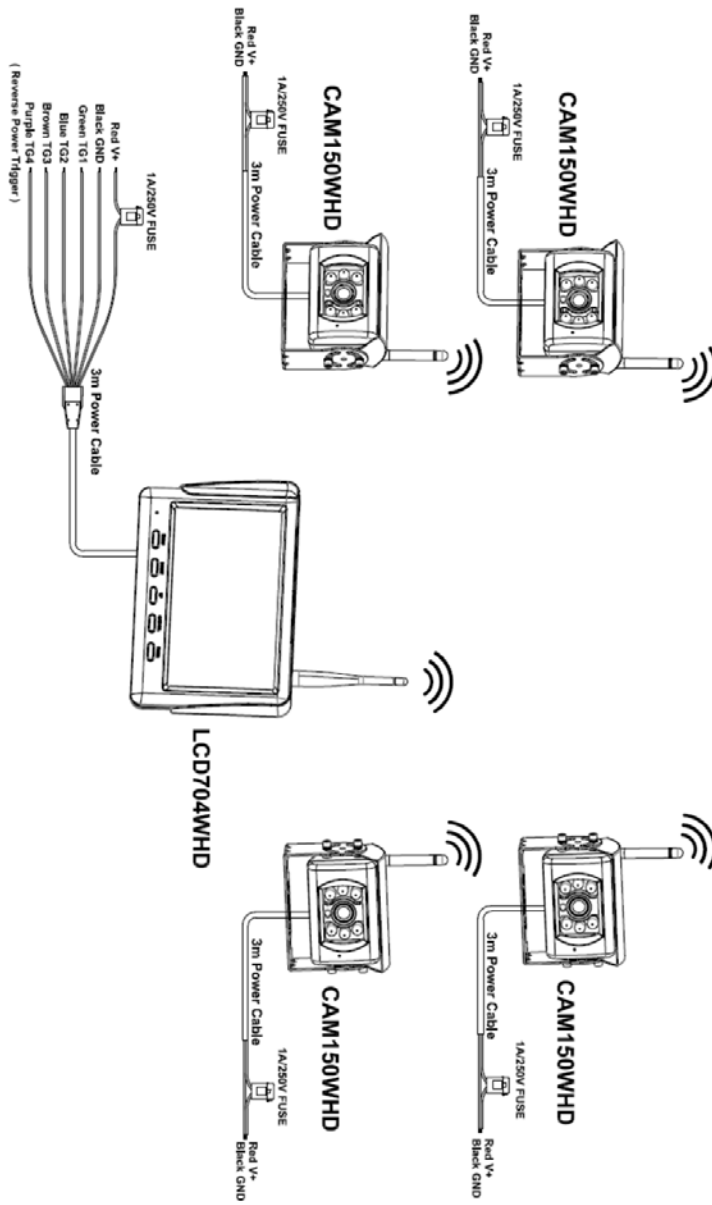

## FCC Declaration of Conformity

This device complies with Part 15 of the FCC rules. Operation is subject to the following conditions, (1) this device may not cause harmful interference and (2) this device must accept any interference received, including interference that may cause undesired operation.

This equipment generates, uses, and can radiate radio frequency energy. If not installed and used in accordance with the instructions, the product may cause disruptive interference to radio communications. However, there is no guarantee that interference will not occur in a particular installation. If this equipment does cause harmful interference to radio or other equipment reception, which can be determined by turning the equipment off and on, the user is encouraged to try to correct the interference by one or more of the following measures:

- Reorient or relocate the receiving antenna.
- Increase the separation between the equipment and receiver.
- Connect the equipment to a different power source from the receiver.
- Consult the dealer or an experienced radio technician for help.

Changes or modifications not expressly approved by the party responsible for compliance could void the user's authority to operate the equipment

This equipment complies with FCC radiation exposure limits set forth for an uncontrolled environment. This transmitter must not be co-located or operating in conjunction with any other antenna or transmitter.

This equipment should be installed and operated with minimum distance 20cm between the radiator&your body.

## **Smart Park® Warranty Card**

### **PLEASE MAIL OR FAX THIS PAGE TO:**

Att: PERFORMANCE GUARANTEE DEPT.,  
International Fax #: +61-2-9437-4555

PO Box 124  
Spit Junction NSW 2088  
Australia

### **Section 1: VEHICLE INFORMATION**

VEHICLE IDENTIFICATION NUMBER: \_\_\_\_\_

YEAR MODEL \_\_\_\_\_

MAKE LICENSE PLATE #: \_\_\_\_\_

PRODUCT SERIAL #: \_\_\_\_\_

### **Section 2: PURCHASE INFORMATION**

DEALER NAME \_\_\_\_\_

DATE OF SALE \_\_\_\_\_

PURCHASE PRICE \_\_\_\_\_

BUYER'S NAME \_\_\_\_\_

### **Section 3: LIMITED WARRANTY**

The Smart Park™ product is guaranteed to be free from mechanical defects for a period of three years when installed by an authorized Dealership.

[www.zorgindustries.net](http://www.zorgindustries.net)

For our full range of driver  
assistance and safety products:



**Reversing Sensors**



**LCD4WM**



**LCD Mirror  
Monitors**



**Commercial  
Camera Systems**



**Passenger Vehicle  
Camera**



**Factory Display  
Integration Units**



**Event Data  
Recorder**



**Cable Harness  
Assemblies**



**High Definition  
Camera**

