

CC 9068



Index

Introductory information	2
1. General	2
2. Security guidelines	2
Installation of the hands-free car kit	4
3. Scope of supply	4
4. Positioning and mounting	6
5. Connections on the electronics box	9
Operating guidelines	12
6. Using the hands-free car kit for the first time	12
7. Handling possibilities	13
8. Voice control	13
9. Handling via Touch screen	14
10. Establishing a <i>Bluetooth</i> connection	15
11. Menu navigation	16
12. Accepting, making, ending calls	32
13. Transferring Calls	33
14. Conference Mode	34
Further Information	35
15. Service	35
16. Appropriate use of this system	36
17. Approvals and declaration of conformity	36

1. General

Dear customer,

Congratulations on purchasing a BURY hands-free car kit. You have chosen a high quality product that is extremely easy to use.

Please read the operating manual carefully so that you can fully enjoy your BURY hands-free car kit. If you have any further questions concerning installation or operation of your car kit, please contact your dealer. He will be happy to give you reliable advice.

You can also contact our hotline. Our phone and fax numbers are listed in the chapter „Service“ at the end of the operating instructions.

Have a good trip!

2. Security guidelines



Installation - who should do it

The installation of this system can be carried out by yourself but please observe the installation requirements of the automotive manufacturer (VAS 1978). During the installation, park the car at a place where the road traffic is not impaired. We recommend to let a specialised workshop perform the installation.



Power supply

This system has been designed for the use in vehicles with an on-board supply system of 12 volts (passenger car). If you intend to install the device in a vehicle with an on-board supply system of 24 volts (lorry), please use a voltage converter. If you have queries regarding this subject, please contact our hotline.



Position, volume

Install the components of the device in the vehicle so that your field of vision is not impaired and the components are not mounted in the impact zone of the passenger compartment or in the airbag inflation zones. The removal of coverings (with and without airbags) or components of the dashboard requires – in some cases – special tools and special knowledge.

Intended use

We shall not be liable for damages or malfunctions due to improper use of the hands-free system. Therefore, do not expose the device to moisture, extreme temperatures or shocks and carefully follow the procedure described in the installation and operating guidelines.



Use while driving

Operate the system only when the situation allows it and when you do not endanger, harm, constrain, or annoy other road users. The volume of the device has to be set in a way that exterior noise is still audible.

Faults

Do not commission the device if you detect or assume a defect. In this case, contact a Bury specialised dealer or our hotline. Improper repair efforts can be dangerous for you. Therefore, only skilled personnel may perform inspections.

Avoid exposure to long periods of direct sunlight when vehicle is parked as this can cause, among others, damage to the readability of the display. The sound functioning of the display is guaranteed up to a maximum temperature of 60° C.

Important:

- ▶ The driver is ultimately responsible for the safe operation and control of their vehicle at all times. You should never use a hand held phone, including sending or reading text or picture messages, while driving.
- ▶ Research indicates that there is a risk to safety when the driver of a motor vehicle is distracted and using a mobile phone while driving can be a distraction.
- ▶ The manufacturer strongly recommends that you use a hands-free solution when driving.

3. Scope of supply

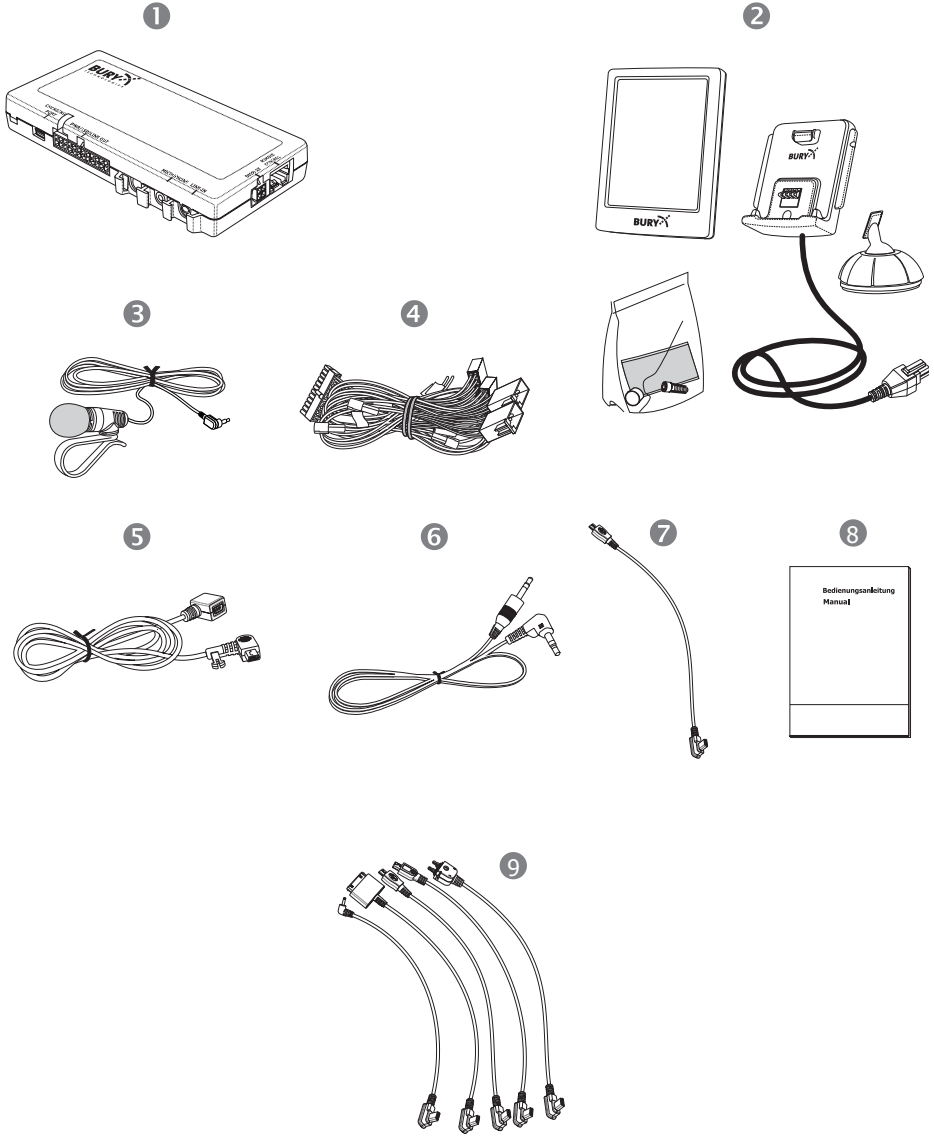

The hands-free car kit (HFCK) is supplied with different combinations of components, depending on the sales regions (countries). The operating manual refers to all versions.

Description of the components:

- 1) Electronics box
- 2) Monitor, holder, installation pad and mounting accessories
Fixing screws for electronics box, rider, screws for the holder and rubber cover, adhesive tape, cleaning cloth
- 3) Microphone
- 4) ISO cable harness
- 5) Extension cord
- 6) AUX IN cable
- 7) Micro USB charging cable
- 8) Quick user guide
- 9) Mobile phone and Smartphone-specific charging cable (does not occur in the kit, is available as an accessory)

Note:

► If certain components are added or omitted you will receive the corresponding information on a separate enclosure.

4. Positioning and mounting

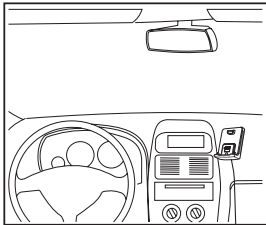
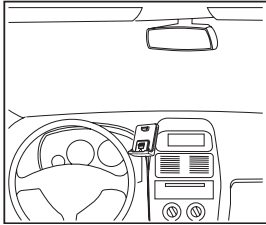

Step 1:

First of all, please choose the most convenient position for the attached monitor on the holder and the installation pad in your vehicle by checking different positions in the vehicle.

If you would like to use the device during your journey, positioning it in the front area on the driver's side is advisable. Sit in the vehicle and check whether you can reach the device without difficulty.

After having found a suitable position for the monitor in the vehicle you can now mount / attach the installation pad / the holder with or without the installation pad accordingly. Please use a cleaning cloth for degreasing the surfaces to which you want to attach the corresponding adhesive surface of either the holder or the installation pad.

The end of the cable with the small Molex connector on the holder is ideally suited for placing through small openings in the dashboard area. This facilitates a practically invisible installation of the cable. Take the length of the cable into account and make sure that it is of sufficient length to reach the intended location of the electronics box.

Important:

- ▶ When positioning the monitor please take care that the monitor does not impair the view onto the road, that it will not be installed in the impact zone of the passenger compartment (amongst others in the airbag inflation zones) and that the cable may be laid without any problems.
- ▶ The installation pad can be affixed just once, removing could damage the adhesive area. In case of high variations in temperatures - depending on the structure and the features - decolourisations of the surfaces can occur during the subsequent utilization.
- ▶ Please avoid direct sunlight on the monitor or high internal temperatures, which can be rapidly reached in parked vehicles. In such cases, remove the monitor of the hands-free car kit from the cradle and put it in the car glove pocket or glove box for instance.

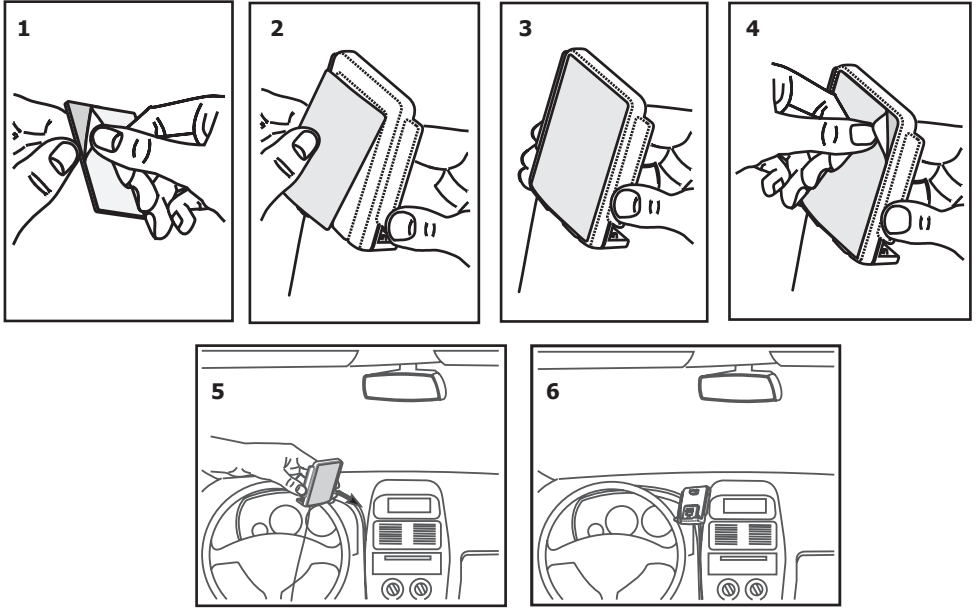
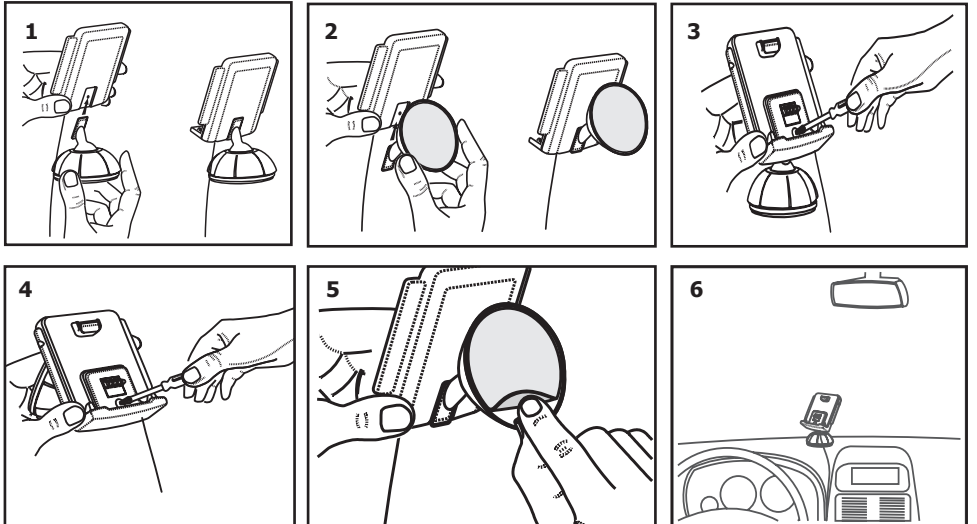
Example of installation 1:**Example of installation 2:**

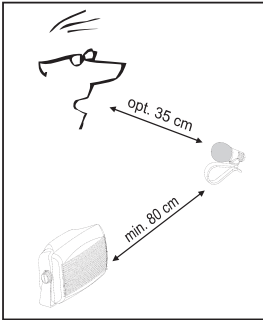

Step 2:

Depending on the vehicle type and its equipment (e.g. airbags), it is reasonable to install the microphone either at the A-pillar, at the sun shield or at the roof interior. For details about the equipment features please refer to the vehicle documents.

Step 3:

Remove or loosen up cladding and covers to be able to install all of the cables in the vehicle as comfortably as possible. Please lay the cables in a way that they do not lie/hang unsecured in the vehicle and that they may not influence the conducting of the vehicle. When laying a cable, please take care that it is not under traction stress but that it has some tolerance. Avoid crushing the cable as damages of the insulation can be caused by friction/rubbing.

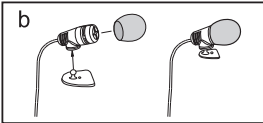
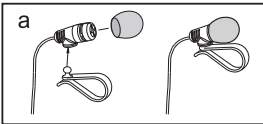

Step 4:

Install the electronics box at a convenient place in the vehicle. This can e.g. be behind the radio, in the glove box, or in the centre console. Please mind that you can access the connections of the box without difficulty. It is possible that you will have to connect the components before attaching the electronics box, if it isn't possible to do this afterwards due to a lack of space. A description of the connections is provided in the section number 5.

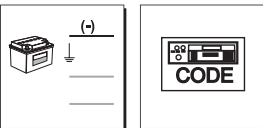

Before connecting the components to the electronics box you should branch off the battery for safety reasons. In doing so, take into account that there might be a radio coding (confer radio manual).

Important:

► Please install the electronics box behind a cover or somewhere you can only reach by opening or unfastening a protective cover / a cover. The terminal box must not hang loosely in the vehicle.

5. Connections on the electronics box

The additional components of the HFCK are connected to the electronics box. The following connections are provided:

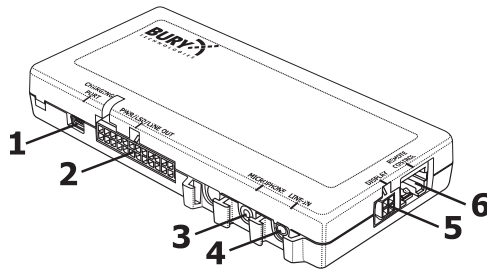

Connection options:

- 1 Mini-USB
- 2 Power supply/ muting using Mute via ISO cable tree
- 3 Microphone
- 4 LINE-IN
- 5 Multifunction display
- 6 RJ45 socket for possible system expansions

Connection 1: Battery charging option using mini USB

You can charge the battery of your mobile phone using a mini USB cable.

Connection 2: Power supply Vehicle Interface Lead (ISO)

The power supply to the HFCK and functions such as the muting of the car radio as well as the voice feedback and playback of music on the car speakers are guaranteed through the ISO cable harness. The pin-assignment of the ISO-connectors can vary depending on the type of vehicle / car radio. To prevent damage from occurring, before using the ISO cable harness, make sure that the assignment is correct. Information is provided about this in the description of the car radio.

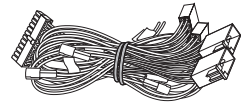

Remove the (a) and the (b) ISO-connector at the back of the radio. Connect this and/or these connectors with the matching jack (5) on the ISO-cable harness. Now connect the connector (4) from the ISO-cable tree with the radio again.

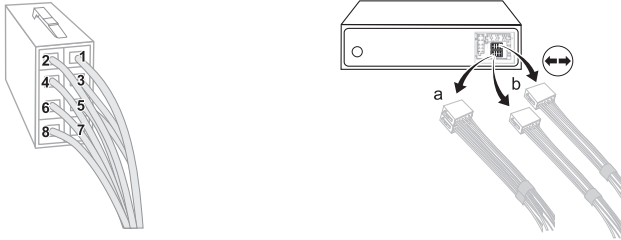

Starting from the black 24-pole Molex connector (connector 1, which is plugged into connection 2 on the electronics box), you will find one yellow (radio muting) and one red (steady plus) cable with plug connectors with a 24-pole plug connector.

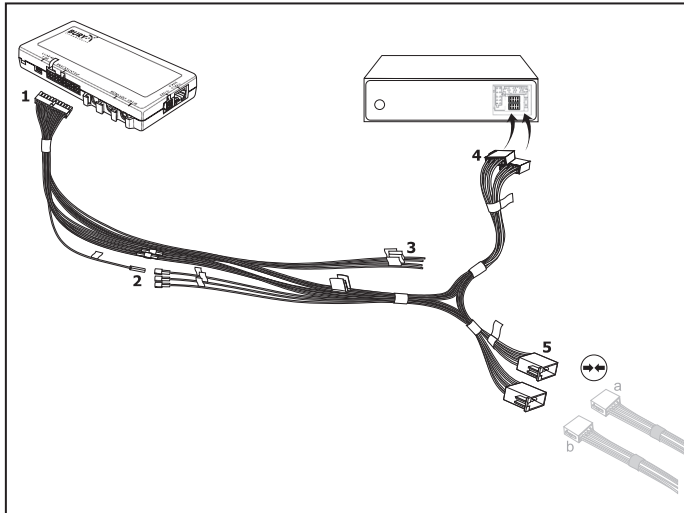

Three other cables are positioned opposite to the single yellow cable (2) for the radio muting. You can also find the correct cable here via Multimeter.

Using the ISO-cable harness, you are able to assign the playback of music and voice feedback during a telephone call to the vehicle's speakers. With incoming telephone calls, the playback of music (by the HFCK or the car radio) is automatically interrupted.

The four open cable ends (3), marked with LINE/PHONE, can be connected to the car radio (if available) using a Phone-In/Tel-NF-Input. This also enables feeding the music or voice playback through the radio. The corresponding required settings must be implemented in the FSE (AUX-Out) and in the radio (AUX-In).

Attention:

► If you also connect the blue cable to clamp 30 (steady positive), the HFCK will be permanently supplied with power. If the vehicle is not running for a longer period, this could lead to a discharge of the car battery.

► If you deviate from the stated description of the connections, it is possible that certain functions on the HFCK (e.g. the on-call duty) will not function correctly.

Connection 3: Microphone input

This is where you plug in the microphone jack. This ensures that neither of the jacks is able to loosen as a result of vibrations.

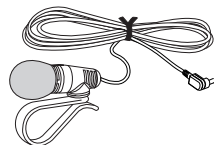

Connection 4: LINE-IN

To connect external music players.

Connection 5: Multifunction display

Please plug the 5 pole plug of the monitor connection cable into this jack.

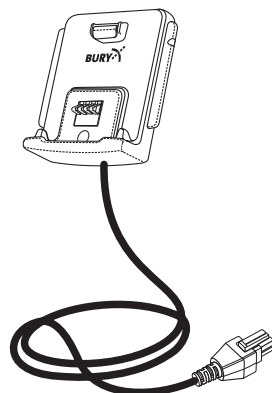

Connection 6: RJ45 socket for possible system expansions

6. Using the hands-free car kit for the first time

After the power supply of the hands free car kit (HFCK) is successfully connected, the HFCK is activated when you have started the vehicle. After this, you have to select the menu language if several are available for you to select. Regional differences may occur in this context. If the HFCK is only equipped with one language then this should load automatically.

You can change the menu language again by selecting the **More** touch-screen field, then selecting the **Settings** in the **Head menu**, and then changing the **Language** in the **Device** menu item.

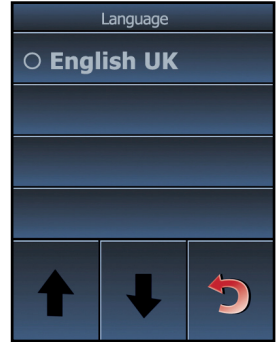

Afterwards you will reach the head menu. Different symbols will appear in the top row - before and after you have connected a phone. These symbols have following meaning:

The loading status of the battery of the mobile telephone

Missed calls / New messages

Bluetooth® profile / Notice of activated Multipoint function

Active Bluetooth connection

Mobile telephone in the A2DP mode

Volume

Signal strength of the mobile telephone network

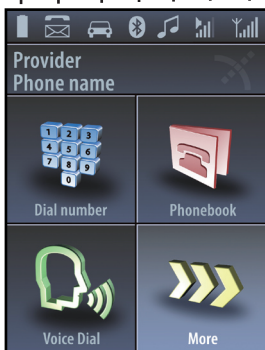

Headmenu with paired telephone

7. Handling possibilities

The system can be operated in two ways:

1. Operation using voice control



Voice dial
commands

The „**VOICE COMMANDS**“ are highlighted in the further explanatory notes.

2. Handling via the touch screen



Touch screen

8. Voice control

The menu items of the HFCK can be selected using voice commands once this function has been activated. There are exceptions, however, when you still have to use the touchscreen. During an active telephone call, for instance, you can't use voice commands. You have to select any additional functions using the touchscreen.

To start the voice control feature, briefly press the head symbol down on the main menu. If the Magic Word function is activated, you can also start the voice control by stating the „**ACTIVATE VOICE DIAL**“ command. In certain situations, however, with an incoming call and activated voice recognition for instance, the HFCK will start the voice control system automatically. The HFCK signals that it is ready to receive a command by emitting an acoustic signal.

If you aren't sure of the right command to use, then simply state „**HELP / WHAT CAN I SAY**“. The HFCK will then read out the commands available for the particular menu in which you currently find yourself. If the HFCK fails to understand one of your commands, or the particular option isn't available, the help function will start automatically and list the possible commands.

Please remember that certain commands are only available if a telephone is connected with the HFCK. When entering voice commands, please ensure you speak naturally, clearly and at a regular speed.

Note:

► With the use of the voice control it is recommended to turn down the volume of components which are independent of the audio system (e.g. a navigation system) or to switch off the broadcast of traffic jam warnings in order to avoid unintended voice entries.

In addition to these commands, the HFCK recognises the numbers from zero to nine. Numbers which are larger than nine must be spoken individually (e.g. 10 = one, zero). To search in the phone book, the HFCK recognises the letters „A“ to „Z“ as well as the NATO alphabet. For the entry of telephone numbers abroad, the command „PLUS“ is also available.

When using voice control, in **all menus** these four commands are always available:



Cancel

breaks off the current action

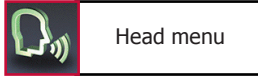

Head menu

back to head menu



Back

one step back

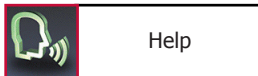

Help

names all commands which are available

9. Handling via Touch screen

The functions of the HFCK can also be called via the touchscreen. Every available command is presented as text (sometimes with supporting graphics) on the display.

The operation can be carried out via possibly existing arrow keys. With the **red symbols** you can cancel an action or go a step back. If you press long you will return to the main menu. With the **green symbols** you can confirm actions.

You can enter a telephone number here

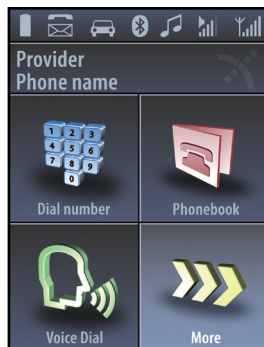

You can open the telephone book here

You can start the voice control here

You can flick through more functions here

Headmenu with paired telephone

If you operate the system via the touch screen function, it will become dirty over time and both the readability of the information on the display and its input functionality will deteriorate. Therefore, please be sure to clean the display as necessary using a damp lint free cloth. Please do not use any detergent.

10. Establishing a *Bluetooth* connection

If you wish to establish a *Bluetooth* connection between your mobile and the HFCK for the first time, you have to activate the *Bluetooth* function of your mobile phone and search for Bluetooth® devices. In this case, search for a device labelled „CC 9068...“. If several devices were identified, please select the HFCK and enter the **PIN number „1234“**. The *Bluetooth* connection (pairing) will then be established between your mobile phone and the HFCK. It is possible that you will also have to click on 'connect' or 'allow data transfer' on your mobile phone if you want to be able to make a connection.

With a connection which has successfully been made, the name of the coupled mobile telephone and of the provider will be shown and the data from the telephone book (SIM card) and the address book (storage of the telephone) are transmitted to the HFCK. Depending on the amount of stored data, this can take a few seconds. If the synchronisation of the phone book is interrupted, e.g. through an incoming call, it is possible that all entries will not be transmitted. If this happens, the phone book should once again be manually synchronised.

Note:

► The telephone book on your mobile phone is generally synchronised by the hands-free car kit at regular intervals. For the duration of this short moment, the voice control will not be available to you and you will receive a corresponding message.

If it is not possible to establish a connection, please check and update the software release (firmware) of your mobile phone or of the HFCK. You will find an overview dealing with this subject on the Internet at www.bury.com.

Note:

► In the internet you can find an overview with a large number of mobile telephones which have been tested with this hands-free car kit. Please note, however, the use of firmware which deviates from the list and is installed on a listed mobile telephone can lead to the fact that certain displays and functions are no longer possible or only possible to a limited extent.

In addition it is possible that you must delete all devices connected to your mobile phone first in order to enable a correct identification of the HFCK and the establishment of a connection. If you have queries regarding the menu navigation, functions and operation of your mobile phone, please refer to the operating guidelines of your mobile phone. Depending on the manufacturer and type, this can differ considerably between phones.

Note:

► If the rechargeable battery of the mobile phone is low, it is sometimes not possible to establish a *Bluetooth* connection.

The HFCK has a memory for the storage of the identification of up to 10 mobile phones. In case an eleventh mobile phone is connected, the oldest entry in the HFCK memory will be cancelled.

If you wish to cancel a *Bluetooth* connection, you can either disconnect it conveniently at the HFCK or at your mobile phone. In addition, the connection is disconnected, if you move too far away from the vehicle while taking your mobile phone with you and thus leave the reception radius of the HFCK.

Please note that the capacity of your mobile phone's storage battery can quickly decrease when the *Bluetooth* function is active. If you do not want to use the *Bluetooth* function anymore, e.g. if you leave the vehicle for a longer period, it is recommended to deactivate this function.

11. Menu navigation

If the voice control function is active then the corresponding menu appears in the display, or the details of the particular function that has been activated. In the following the individual menu points will be explained.

Dial Joe Bloggs

With this voice command (is not shown on the display) you can immediately call a contact from your telephone book with active voice control.



Dial Joe Bloggs

Note:

► When doing so, it is important that the stated name exactly corresponds with the entry stored in the phonebook. Please note that telephone book entries, which are only shown in capital letters must be spelt out. Example: ADAC.

If the names have been reversed then the command changes to:
„DIAL BLOGGS JOE“.

Dial number

It makes sense to divide telephone numbers in short number blocks of 3-4 digits and to say them this way. At each break, the HFCK repeats the number block and waits for the next number block. After the signal tone you can respectively continue your announcement.

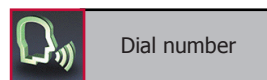

Enter the area code. Enter the first numbers of the actual telephone number. Enter the remaining numbers of the actual telephone number. When you have entered the last number block of the telephone number, you can check the complete telephone number once again with the voice command „**PLAYBACK**“.

Here are some more commands:

The complete entry will be deleted, or the previous entry.



The last digit is deleted.



A telephone connection is being established.



The last number block will be deleted.



Phonebook

Since your phonebook is scanned with the first coupling of your mobile phone with the system, it is immediately available to you and is stored until you delete the mobile phone from the phone list. The telephone book data can of course only be seen or changed by you.

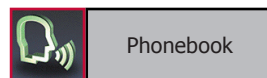

The entire list is read aloud to you. With „**STOP**“ you can stop the process and select the respective entry. With „**NEXT**“ or „**NEXT PAGE**“ and „**PREVIOUS**“ or „**PREVIOUS PAGE**“ you can navigate in the list. With „**DIAL**“ the telephone connection will be made. You can also jump directly to one of the entries shown by activating the entry number. E.g.: „**SELECT ENTRY THREE**“.

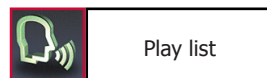

<Joe Bloggs> is a placeholder for an entry from your phonebook. If you select a name, you go directly to the respective entry.



Here you can search for entries through a letter field. Read out the first letters of the first name and surname (depending on the sort sequence) which you want to find. The corresponding letter appears in the top line and will also be read out to you again.

If several names are available in your telephone book with the letter you entered, then you can limit your search further and enter up to three additional characters for the fast search. Via the display, you get the information highlighting which additional letters the HFCK finds in your telephone book. The rest is correspondingly greyed out.

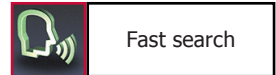

Via the „**SELECT**“ command you can confirm your input. The display then shows you the telephone book with the entry which best matches your input. With the commands „**DELETE LAST**“ or „**DELETE ALL**“ either the last letter or all of the letters you entered are deleted.



If you would like to activate the function via the Touch screen, please press down on the arrow downwards symbol for two seconds, which also states the letters „**ABC**“.

Via the „**GET DETAILS**“ command, you will find all of the telephone numbers that are listed under this contact. When using the Touch-screen, click on an entry.

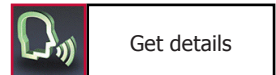

If your contacts are stored in the telephone's memory, then depending on the type of mobile phone, you can allocate four or more telephone numbers to a single contact. The terms are not standard and may have different designations depending on the manufacturer of the mobile phone, or can be set by yourself*:

„**HOME**“,
 „**MOBILE**“,
 „**WORK**“,
 „**GENERAL**“.

* This function depends on your mobile phone.

Some mobile phones support these categories only partly, however, or not at all. To nevertheless display the telephone numbers, unknown entries are listed within your contacts using the <Number> category. You get a maximum of just one number from the SIM card, however (this is always designated with SIM), and four numbers from the telephone memory. If categories are only partly supported, the listing can subsequently be mixed. Example:

Private

+44...

Mobile

+44...

Number 1

+44...

Number 2





+44...

SIM

+44...

If you say only „**NUMBER**“, all stored entries under this name will be read aloud. This command is not active in the event of operation via the Touchscreen.

In case you have stored more than one telephone number under a contact name, you can also directly call through the category, e.g. „**DIAL JOE BLOGGS HOME**“.

	Dial home
	Dial mobile
	Dial office
	Dial general
	Dial sim

	Dial number 1
---	---------------

	Number
---	--------



In addition you can allocate a phonebook entry with an own voice command (voice tag). This is recommended for names which are difficult to pronounce. In these instances, the use of nicknames or abbreviations is recommended.

Clearly speak the command into the microphone, the HFCK repeats this and you can then make a call to the desired discussion partner from the head menu with e.g. „**CALL CUSTOMER ONE**“.

In all the HFCK can store 150 voice commands. This voice command (voice tag) is valid for all numbers which are allocated to this contact name. A corresponding inquiry follows about which of these numbers you want to call.

Note:

► In order to make voice recognition easier for the HFCK, please do not use voice commands for your voice commands (voice tags) which are also used by the HFCK.

	Voicetag
	Store
	Delete





Redial

The number which was last selected can be selected once again.

	Redial
---	--------

Call lists

Here in a chronologic sequence all calls are listed which have been made, missed or accepted. The name of the caller / the person being called and the telephone number are displayed. If it is not possible to allocate a contact from the telephone book to the telephone number, the number alone appears without additional information. You can have the telephone number read to you and if you want call back. The navigation within the lists is carried out analogue to that of the phonebook.

	Call lists
	Dialled calls
	Received calls
	Missed calls

Music

If you initialise this menu item without having connected a music playback device, you will be informed accordingly via an announcement and / or a pop-up. The possibilities surrounding the music playback are explained below.

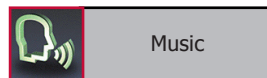

Note:

► Please take the road traffic rules and regulations into account pertaining to the country in which you are travelling. In some countries drivers are not allowed to hold a mobile telephone when they are driving, even if they are using it to play back music rather than making a phone call.

The Music Player

The following functions are available in the music player:

- |◀◀ Back (title by title)
- |▶▶ Skip (title by title)
- || Pause
- ▶ Play
- Stop

Via the loudspeaker symbol, you reach the plus and minus button for controlling the volume. The display reverts automatically after five seconds. Using the red arrow, you are able to go one step back in the menu, or by clicking on it longer, return to the main menu straight away.

As the different mobile telephone manufacturers menu guidance systems differ, the selection / options designations can also differ. Please read your mobile phone's instructions manual for more information on this topic.

Music devices

This is where the telephones are listed that have been successfully connected with the HFCK via A2DP. The listing is completed analogous to the telephone list. As a rule, with an active multipoint function, the music playback is always reproduced by the primary telephone. In this submenu, however, at variance with this you can select the secondary telephone as the source.



A2DP active

Some telephones initially connect in the A2D profile and then via the hands-free profile. This leads to problems, as the music playback is then started automatically. If this process has to be prevented, the A2DP function must be deactivated. If the function is deactivated it is not possible to connect any telephone in the A2D profile with the HFCK via the previously described ,music devices' submenu, however.

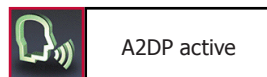

Messages

Using this function, you are able to show and to read out text messages which are saved in the mail box of your mobile phone via the HFCK. The HFCK is able to take and save up to 100 SMS messages from your phone's memory and SIM card. If you receive additional SMS messages, then these replace the oldest entries in the HFCK. If it isn't possible for all SMS messages to be imported then you will receive an information message.

You can access any SMS messages which have arrived subsequent to connecting the HFCK with your telephone in the menu

„**NEW TEXT MESSAGES**“. The envelope symbol appears in the status bar of the main menu for your information.

You can select these straight from the main menu with the commands „**READ NEW TEXT MESSAGE**“ (these will not be shown in the display).

If you want you can call the sender back.

If you call the text messages via the touchscreen, these will not be read out automatically. Open an entry and press briefly on the text to start the audio playback of the message.

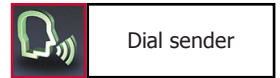
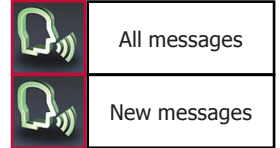

Settings

In this menu point, you can configure the HFCK through five further submenus. These are **Bluetooth**, **Voice dial**, **Audio**, **Display** and **Device**.



Bluetooth

In the telephones menu item, in the telephone list, the telephones are listed which have previously successfully been connected with the application via *Bluetooth*. The list is able to include a maximum of ten telephones. If an additional telephone is connected the oldest entry is deleted. The car and clef symbols after the telephone name display show the *Bluetooth* profile with which the corresponding mobile phone was connected.



With the „**CLEAR LIST**“ command it is possible to delete the full telephone list. You are able to assign an individual „**PIN CODE**“ for the Bluetooth connection in the next menu item. Your own code must be at least four figures long – with a maximum of eight being allowed.

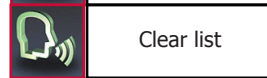
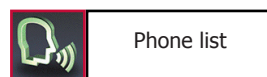

Select a telephone from the list. Here, every telephone can be connected, disconnected, deleted or set as the standard. The standard telephone will always be sought as the first telephone if the **automatic connection** has been activated and it is always at the top of the list of telephones. In addition to this, with an activated Multipoint function, this is always the primary telephone. If the mobile phone also supports music play back via AD2P, this *Bluetooth* profile can also be connected or disconnected in addition to the hands-free mode. This means it is possible to play back music from a telephone but to take phone calls via the HFCK at the same time. With incoming calls or the activation of the voice control, the play back of music is automatically interrupted.

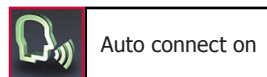

Voice dial

In this submenu you can carry out the following settings:

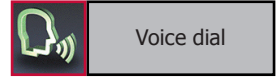

Activation or deactivation of the magic word:

If you activate this function you can start the voice controlled operation of the HFCK straight from the main menu with the pre-set voice command „**ACTIVATE VOICE DIAL**“. With this function, you are able to leave both your hands on the wheel. To indicate that you are able to activate the HFCK using the magic word, an exclamation mark appears in the voice control symbol.



Note:

► If you state this command during a conversation with a passenger or this passage should be read out over the radio for instance, it is possible that the voice control function will be unintentionally activated.

Activating or deactivating the Advanced Help feature:

If you activate the advanced help, then in certain menus you receive additional assistance during voice control operation about the commands which you are able to use. With other commands, the HFCK will ask you if you really want to complete them.

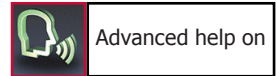

Activating or deactivating the Audio feedback:

If you activate the audio feedback, during the touch screen operation you receive voice support (e.g. the phonebook entries and all of the message windows are read aloud to you). Your selection is shown through an information field.



The HFCK works in general independent from the speaker, that means it can immediately be operated without a ‚voice training‘. Then user training is only needed if you speak a strong dialect. The HFCK reads twenty terms aloud to you which you have to repeat so that the system can „get used to“ your voice.

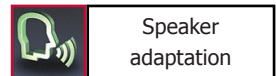

Here you will receive short instructions about the essential functions of the HFCK.



Audio

In this area you have the possibility to change the audio settings of the HFCK.

The HFCK is sold with four Ringtones from which you can respectively select one. With „**NEXT**“ or „**PREVIOUS**“ you can navigate in the list. With „**ACCEPT**“ the ring tone is selected. If you would like to use your mobile phone's ring tone, please select the first entry in the menu. Please remember, however, that not every mobile phone can transfer its ring tone to the HFCK.

The volume level for the voice feedback and the selected ring tone can be set in an additional sub menu. Available as voice commands are „**LOUDER**“, „**LESS**“, „**MAXIMUM**“, „**MINIMUM**“ and „**ACCEPT**“.

For some radios it may cause problems if the HFCK starts with voice response immediately after the mute signal. Some radios need some time for a corresponding activation and reaction to the mute signal. This will be indicated to you through the fact that you don't hear the signal tone at the start of the voice control. To avoid this effect, you can enter a maximum delay of up to three seconds in the „**MUTE DELAY**“ menu item. It is only after this time has elapsed that the HFCK begins with the voice feedback.

Certain mobile telephones offer the possibility of being able to install and operate a navigation solution. On many mobile phones, the suggested directions are only transferred via the Bluetooth A2DP profile. If you have not connected a suitable cable to the LINE-OUT output of the HFCK and to the radio however, you are not able to hear these instructions.









With the **External Audio** menu item, it is possible to place these instructions on the PHONE-OUT output of the HFCK. This means that the direction instructions are read out in monotone and the radio is also muted. The HFCK takes priority with its functions, however, which means that if the voice control is active or in the event of an incoming call, any direction instructions that are being issued at that time will be muted.

Please note:



► If the function is activated it is not possible to listen to music via A2DP via the LINE-OUT output.

The „**Balance**“ command is used to compensate or adjust the volume between the left and right side.

Voice Command „**Installation**“ is used to select one of two options (Option 1, Option 2) calls and music playback in the car. Their extensive description can be found in Chapter 5.

	Audio
	Ringtones
	Play
	Select
	Volume
	Speech
	Ringtone
	Mute delay

	External audio on
---	-------------------

	Balance
	Installation

Music (as well as phone call but involving four speakers) - uses 4 speakers and an internal amplifier in the box. Car speakers are disconnected from the radio and connected to the box (active). RadioMute line is also active and will turn off the radio (Mute or switching to PHONE-IN mode, depending on the radio). In both cases the audio signal is available also on the LINE-OUT socket in the box.

- **Option 2** (phone call through the box, music through the car radio):
Connection - ISO-power connector plugged in, ISO-audio connector connected.

Phone call - as in **Option 1**.

Music - the audio signal is available in the LINE-OUT socket of the box (it should be connected to the LINE-IN socket of the car radio). Car radio amplifier is being used to play the music (box inactive, RadioMute inactive). Usually there is a need to choose the AUX-IN mode on the radio (if one exists). The audio signal for a phone call is available also in the LINE-OUT socket on the box.

Display

This menu point makes it possible for you to adjust the display in a range of different ways.

In order to avoid the blinding effect especially when driving at night, you can activate the Sleep mode. This causes the display to shut off after either 15, 30 or 60 seconds. With an incoming call, the HFCK activates the display automatically.

In the Illumination menu item you can change the intensity of the light diodes in the display. As voice commands „**MORE**“, „**LESS**“, „**MINIMUM**“ or „**MAXIMUM**“ are available. The confirmation follows with „**SELECT**“.

To be able to read the contents of the display optimally during different light conditions, in the next menu item, **Day/Night mode**, you are able to invert the display.

In the Colour theme menu item you can adapt the background colour of the display to the colour schemes of the display in your vehicle. Several different possibilities are available. Simply say the colour of the theme and confirm your selection with „**ACCEPT**“.

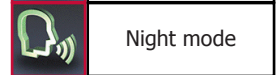
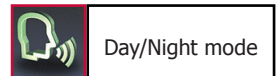
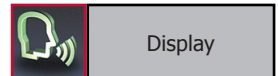

Device System

In this menu you can make the settings concerning the answering of calls, the menu languages, the telephone book options, for the system itself, and for the willingness to answer calls.

With the **call answering** function you can specify as to whether you want to answer an incoming call manually via the touchscreen, by voice command, or automatically. If you select automatic call answering, the call will be answered automatically after two rings. You can then decide whether to accept or decline the call.

Depending on the sales regions (countries) the HFCK includes one or several language packages. If several are available you can select the suitable **Language** which you want.

Note:

► The BURY Service offers the possibility of being able to change or add language packages. This service is available against payment. You can find out about it via the BURY hotline. The BURY distributors in the different sales areas are also able to offer this service. Please contact them accordingly. Their contact details are provided at www.bury.com.

You have to set the language when you use the device for the first time and after updating the firmware or loading factory settings.

In the **Phone book options**, you are able to invert the names of the entries in your telephone book in the HFCK. For example: Bloggs Joe becomes Joe Bloggs.

Note:

► Depending on the telephone, it may also be the case that entries are sorted differently. For this reason, some start with the first name and others with the surname. In such a case, this function would not be any help. The maintenance of the data in your telephone, possibly via a PC with the corresponding communications software, can rectify this.

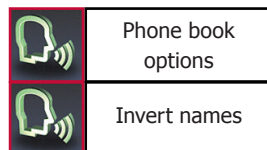
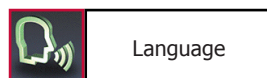
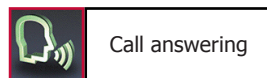

You can also import the telephone book manually here once more, if, for example, you saved a new telephone number / contact in your mobile phone during a Bluetooth with the HFCK.

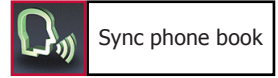

Under the System heading, you receive information about the software and hardware installed in the HFCK under **Version info**. If you ascertain that more recent firmware has been released for your hands-free car kit, you can update the HFCK under the Software Update menu item and by using the BURY Update Suite.

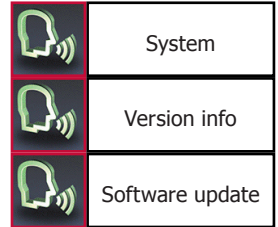

Please note:

▶ Do not interrupt the power supply to the smartphone during the update.

If you have changed certain settings but the HFCK doesn't work in the way in which you wanted it to, then you can reset the HFCK to the settings which were stored in it when you received it using the **Factory setting** function.



Setup: loudspeakers / microphone

In this submenu you can make volume level adjustments for the loudspeaker and microphone on the HFCK for your own spoken commands and the output level of your conversational partner. This makes sense with long journeys in areas with a) continuously changing network providers and b) different geographical features (e.g. frequent changes between rural and urban environments).



Memo

If you want to make a note of something important either after or during a trip or maybe during a telephone call, it is often the case that you don't have anything to write with at hand or the traffic situation prevents you from doing so. With this function you are able to save information that is important to you without posing a risk to yourself or others.

A voice memo can be saved directly from the main menu or during a telephone call. **Private** and **general** voice memos are differentiated between.

It is possible to save up to 10 voice memos per mobile phone signature. The column that moves from left to right during the recording indicates the remaining recording time that is available. The current recording time is also displayed in the same way. The maximum possible length of the memos totals two minutes. If the recording time has run out, this will be displayed accordingly. To be able to record additional memos, you then have to delete the old ones.

In the list, the memos are numerated from 1 to 10 so you can initialise them with the voice control feature using the command „**NOTICE 1**“ or simply „**1**“. Underneath this, you can see the recording time that this memo takes up. Any memo that is made during a telephone call is always a private memo.

Note:

► When recording telephone calls, please take the privacy of your conversational partner into consideration and tell them that you would like to record parts of the telephone call.

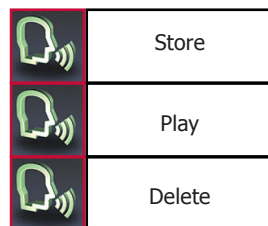
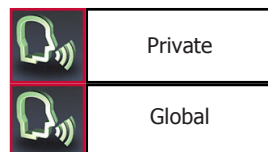
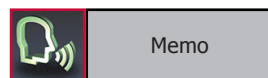

Examples of private memos are addresses, telephone numbers or internet sites which you want to make a note of for later during your journey or during telephone calls.

You can create a general voice memo without having a mobile telephone connected to the HFCK. This means that every driver is able to record, listen to or delete a memo irrespective of whether they have a phone or not. The maximum recording time totals two minutes. If the memo is not listened to before the HFCK is switched off, then after it is switched on, a message appears via a pop-up stating that a voice memo which has not yet been listened to is available. If the Audio Feedback is activated this message is also read out.

If a general voice memo is already available and you would like to record a different one, you will be asked whether you would like to overwrite the old memo.

General voice memos are especially suited to vehicles which have continually alternating drivers, e.g. delivery vehicles. This means that the next driver can be instructed accordingly if someone forgot to refuel or the vehicle has a flat tyre, preventing it from being driven.

12. Accepting, making, ending calls

You will be alerted of an incoming call via the voice output and the ring tone. Your vehicle's sound system will switch onto mute. If the caller sends their telephone number with the call, this will be shown in the display unless the number is saved in your phone. If an entry for the number is saved in your phone, then the name of the caller will be read out. If the caller hides their number, this will be indicated in the display.

In the standard setting, you can only accept or decline an incoming call via the touchscreen. If you would like to accept the call, simply press down on the symbol on the left. If you don't want to accept the call, please press the symbol on the right.

During the call, you have the possibility to regulate the volume of the voice of your discussion partner through the **minus(-)** or **plus(+)** field.

By pressing down the yellow arrows you reach a sub menu. Here, you are able to select a Keypad, with which you are able to send DTMF tones (e.g. to check on your mailbox).

The **Private mode** is an additional sub menu item. If you activate this, the telephone call is transferred by the HFCK to your mobile phone and it is no longer possible to hear the voice output of your conversational partner over the car's loudspeakers.

Please note:

► Please pay attention to the country-specific legislation on making phone calls in your car.

With the sub menu item **Mute**, the microphone in your vehicle is muted. You are then able to communicate with a passenger, for instance, without the person who is calling you being able to hear you. If you would like to activate this function, you should inform the person with whom you are telephoning accordingly as they won't be able to hear you at all.

The next function is the telephone call **Hold** function. In contrast to the muting, your conversational partner receives an acoustic signal that serves as a wait signal. In contrast to the possibilities offered by a mobile phone, you are not able to initialise an outgoing call via the HFCK as long as another one is being held.

Under the final sub menu in the listing, **Reject active**, you are able to end a telephone call. This has the same function as pressing down on the red hand during a telephone call.

If a telephone conversation is active when you switch off your vehicle's engine, the hands-free car kit will remain running until the call has been ended.

13. Transferring calls

Transferring calls is to be understood as being the acceptance of a call during a telephone call and alternating between two conversations.

Note:

► Please remember that your range of functions can vary depending on the type of mobile phone. Please find the relevant details in the instructions manual for your mobile phone.

If you receive another call during an active telephone conversation, you will be informed of it via an acoustic signal. You now have the option of either rejecting the call (the **red symbol**) or accepting the call (the **green symbol**). If you accept the call your previous call will be put on **hold**. Your conversational partner will be indicated with .

You now have the following options:

1. Using **swap** you can switch between your different callers.
2. You can **reject the active call**.
3. You can **reject the held call**.
4. You can activate the **private mode**.
5. You can activate the **mute**.
6. You can activate the **keypad**.

14. Conference mode

The hands-free car kit provides you with the possibility of merging up to seven conversations to create a conference. This means that all participants can talk to each other at the same time.

If you receive a further call during an active telephone conversation, you can merge both conversations into a conference. To this end select the **merge** command (**conference** is shown in the display).

During a conference, you have the following options:

1. You can **reject the active call**. (the conference ends)
2. You can activate the **private mode**.
3. You can activate the **mute**.
4. You can activate the **keypad**.

If you receive a further call during a conference, you can add this to the conference using the **add to conference** command or switch between the conference and conversational partner using the swap command.

Note:

► The current mobile telephone networks only permit the use of a maximum of two lines.

If you are using both lines and you receive a further call, you have the following options:

Reject call

Accept call

->Your active connection will be ended and replaced by the new connection.

15. Service

In case of general or technical queries, suggestions and comments, please do not hesitate to contact our team at any time. Suggestions and feedback are always welcomed:

Administration:
BURY GmbH & Co. KG
Robert-Koch-Straße 1-7
D-32584 Löhne
GERMANY

Producer:
BURY Spółka z o.o.
ul. Wojska Polskiego 4
39-300 MIELEC
POLAND

Hotline: +49(0)180 5 - 842 468*

Faxline: +49(0)180 5 - 842 329*

* 0.14 €/min. Deutsche Telekom AG landline,

the costs of international telephone calls which are made from abroad can vary.

E-Mail: hotline@bury.com

Warranty / Service desk:

The duration of the warranty for the components of this product totals two years subsequent to the date of sale to the end customer. Any warranty claims you may have as an end customer are to be asserted towards your contractual partner. If the corresponding contractual partner is not able to rectify a corresponding fault, please exercise your rights of purchase. If subsequent to agreement with your contractual partner the product is to be sent directly to the manufacturer, then please send it, along with a detailed description of the fault in the German or English language and a copy of the proof of purchase, directly to our service team:

BURY GmbH & Co. KG
Im Hause DPD Depot 103
Robinienweg
D-03222 Lübbenau
GERMANY

Specific explanations regarding the assertion of claims based on defects of the product (warranty / guarantee / service) for certain countries can be found at the end of these instructions.

Information on the disposal of electrical goods in the EU

The crossed out wheellie bin symbol means that electrical and electronic products, batteries and accumulators must be disposed of separately in the European Union. Please do not dispose of any such products in your normal household waste. As the owner of a product of this sort you are legally obliged to dispose of it at your local dumping site or recycling centre, where you are able to leave your waste electrical goods free of charge.

16. Appropriate use of this system

This hands-free car kit is only intended for use with *Bluetooth* mobile telephones and music playback systems in motor vehicles. When using this system, please comply with the regulations and laws specific to the country in which you are driving and the instructions provided in the guidebook for the mobile telephone that you are using.

17. Approvals and declaration of conformity

Purchase and production as well as service and sales at BURY are subject to tough quality and environmental management conditions according to ISO 9001 and ISO 14001. The telematic unit has



the CE approval pursuant to the R&TTE 1999/5/EC regulation



e1 type approval pursuant to the 72/245/EEC (2006/28/EC) regulation
'Electro-magnetic compatibility in vehicles'

You can request a conformity declaration from the manufacturer of this product by post under the manufacturer's address which is stated above, or by writing to the following email address:
ce_conformance@bury.com

Please provide your email request in either English or German.

Version: 07/2012

25.1531.0-01-310712

Subject to change. Errors and omissions excepted.

The *Bluetooth*[®] word brand and the *Bluetooth*[®] logos are owned by Bluetooth SIG, Inc.

All use of these brands by BURY Technologies takes place within the scope of the corresponding licence. All rights reserved.

All of the other stated brands are owned by their corresponding owner.

EXPRESS WARRANTY AGAINST DEFECTS – AUSTRALIA
EFFECTIVE 1st JANUARY, 2012

This product if imported by Point to Point Technology Pty Ltd is warranted in Australia to be free from any defect in material and workmanship, subject to the following terms and conditions.

Who provides this warranty:	POINT TO POINT TECHNOLOGY PTY LTD 2/2 KEYSBOROUGH CLOSE, KEYSBOROUGH VIC 3173 TOLL FREE: 1300 550 720 EMAIL: service@ptp.net.au
Geographical Region:	PRODUCTS PURCHASED IN AUSTRALIA imported by Point to Point Technology Pty Ltd
Warranty Period:	2 YEARS FROM DATE OF PURCHASE (please retain your receipt as your proof of purchase will be required to valid warranty claim)

WARRANTY CLAIM PROCESS

In the unfortunate event of a failure of your product, please contact Point to Point Technology Pty Ltd (PTP) on our Toll Free number: 1300 550 720. PTP will ask you to provide evidence of your purchase receipt to establish the warranty claim is within the 2 year warranty period. Failure to provide your purchase receipt will result in PTP rejecting your warranty claim. PTP offers an advance replacement of your faulty product. Please note our advance replacement units are a like-for-like product and may be refurbished units that are of the exact same model and version. Goods presented for repair may be replaced by refurbished goods of the same type rather than being repaired. Refurbished parts may be used to repair the goods. Upon validation of your warranty claim, PTP will send your replacement unit freight-paid and include a pre-paid return bag for the return of the faulty product. If you choose do not wish to proceed with the warranty claim, you must return the replacement unit to us using the pre-paid return bag. Failure by the customer to return either unit within 14 days may incur a charge for the cost of the replacement unit.

Warranty Exclusions

Failure to provide a proof of purchase will result in your warranty claim being rejected. Product failure due to customer misuse, abuse or abnormal use. Failure by the customer to take reasonable care. Failure due to not using the product in accordance with instructions stated in the manufactures user guide. Product failure due to recommended installation procedures not being followed as stated in the manufacturer's user guide.

YOUR RIGHTS UNDER THE AUSTRALIAN CONSUMER LAW

Our goods come with guarantees that cannot be excluded under the Australian Consumer Law. You are entitled to a replacement or refund for a major failure and for compensation for any other reasonably foreseeable loss or damage. You are entitled to have goods repaired or replaced if the goods fail to be of acceptable quality and the failure does not amount to a major failure.