

PURITY RO

Countertop Reverse Osmosis Water Purifier

Delicious, fresh water at your fingertips.



KEY FEATURES

- Easy to refill.
- 2L treated water capacity
- Removes impurities and improves the taste and cleanliness of your drinking water
- High quality output with low maintenance costs
- Compact, stylish and innovative design
- No installation or water connections required
- No waste water.

Enjoy the freshest, cleanest water possible with the **Purity Reverse Osmosis Countertop Water Purifier**.

Purity Reverse Osmosis systems are among the best appliances you can find on the market to improve water taste and quality. With the water quality of our environment worsening, we have been prompted to design and manufacture this compact, domestic RO purifier to meet these challenges with the highest quality solutions.

With the Purity Series you will enjoy the improved taste of water for drinking, coffee, juice and ice cubes and any other drinking water use. RO water also enhances the flavour of food when cooking. Enjoy healthier water for your whole family.

4 Stage Filtration & Booster Pump:

- Stage 1: Prefilter PP5 Micron - This stage removes particles suspended in inlet water.
- Stage 2: Prefilter Carbon - Removes free chlorine, odor, organic contaminants, pesticides and chemicals that contribute to undesirable taste and odour.
- Stage 3: 75GPD RO Membrane - This is the heart of the Purity Series, and removes contaminants down to a molecular level.
- Stage 4: Post Filter Carbon - Removes any remaining odours and tastes.

Water Reservoir	2L (Treated) 4L (Untreated)
Housing Material	Black
Electrical Operation	24W
Electrical Adaptor	100-240V 50/60Hz
Product Dimensions (WxDxH)	250 x 380 x 415 mm
Distance Under Tap	220 mm
Warranty	12 months

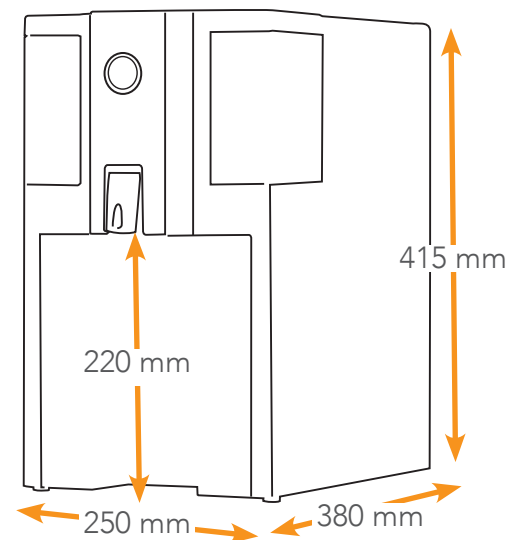

**AQUA
COOLER**

Your Partner in Cool.