

zip **SERIES**



zip **NAVIGATOR**

User Manual

VERSION 1.3



MGI

zip NAVIGATOR

Contents

Thank you for purchasing the Game Changing MGI ZIP Navigator motorised buggy. To get the most out of your buggy please follow these quick steps before use.

Register your buggy online (section 1.0)
Assembling the buggy (section 3.0)
Charge the battery (section 4.0)

For Customer Support, please contact MGI directly for immediate and professional advice.

Email: customerservice@mgigolf.com

LIVE chat: visit www.mgigolf.com

Toll Free within Australia: 1300 644 523 (excludes mobiles)
Western Australia / International Phone: +61 3 8872 6700

Local Service Centres: visit www.mgigolf.com to locate your local service centre.

NOTE: This user manual was correct at time of printing. The online version is the most up-to-date and must be referred to as the correct version. To download the most current user manual please visit www.mgigolf.com. Images shown throughout this manual may not be of the particular model you have purchased, however the instruction they refer to is for the model in the user manual.

1.0	Registration	04
2.0	What Is Included	04
3.0	Assembling the Buggy	05
3.1	Attaching the Rear Wheels	05
3.2	Rear Wheel Positions	06
3.3	Unfolding	07
3.4	Folding	08
3.5	Fourth Foldable Rear Wheel	09
3.6	GPS Holder and Top Handle Compartment	09
3.7	Inverting Rear Wheels	09
4.0	Battery Charging & Connection	10
4.1	Initial Charge	10
4.2	Connecting the Battery onto the Buggy	10
4.3	Charging the Battery after Use	11
5.0	Fitting the Golf Bag	11
6.0	Operating the Digital Top Box	12
6.1	Top Box Display	12
6.2	Start / Stop the Buggy	12
6.3	Turn the Buggy Off	13
6.4	Battery Level Indicator	13
6.5	Unit Measurements	13
6.6	Distances Modes	13
6.7	Competition Mode	14
7.0	Remote Control	15
7.1	Charging Your Remote Control	15
7.2	Forward Arrow	15
7.3	Down Arrow	15
7.4	Left and Right Arrow	16
7.5	Speed Control – Manually and Remotely	16
7.6	Keypad Unlock and Lock	16
7.7	Remote Range and Safety Stop	16
7.8	Pairing a Remote	16
8.0	Gyroscope Straight Tracker Navigation System	17
9.0	Warranty	17
9.1	Warranty Policy	17
9.2	Warranty Exclusions	18
9.3	Parts Installed During Warranty	18
10.0	Preventative Maintenance Program	18
10.1	Cleaning Your MGI ZIP Buggy	19
10.2	Rear Wheel Axles Maintenance	19
10.3	Upper and Lower Bag Strap	19
10.4	Correcting the Alignment	19
10.5	MGI Service Schedule	19
10.6	Service Record for All Buggies	21
11.0	Service and Repair Centres	22
12.0	Purchasing Parts and Accessories	22
13.0	Contacting MGI	22
14.0	Contacting Local Agent	22
15.0	Frequently Asked Questions	23

3.2 Rear Wheels Positions

The MGI ZIP buggy is designed to allow the rear wheels to be in two positions. The position is determined by where the wheel is locked on the axle in either of the two grooves (see picture). The drive position is used during the normal operation of the buggy. The free wheel position is used to freely push the buggy should you experience battery or buggy issues on the course.

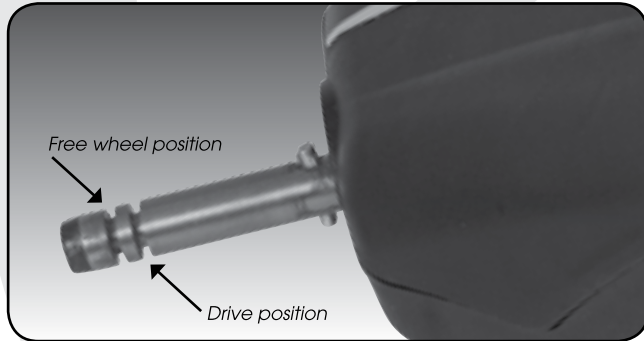

i. Drive position – Lock the wheel onto the groove closest to the battery base. To do this, press the grey release button on the wheel hub, push the wheel on to the axle as far as possible. To test for drive position try rolling the wheel backwards. If you feel resistance then the wheel is now in drive position and ready to use. Repeat for both wheels.

ii. Free wheel – Lock the wheel into the groove closest to the end of the axle. To do this, press the grey release button on the wheel hub, push the wheel on to the axle and release the release button onto the groove. To test for free wheel position try rolling the wheel backwards. The wheel should spin freely with no resistance. Repeat for both wheels.

3.3 Unfolding

Please see below the steps to unfold a ZIP Buggy Handle.

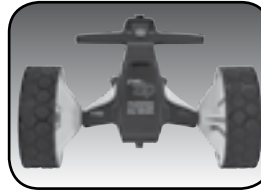

Step 1: Ensure both rear wheels are attached.



Step 2: Release Fold Lever.



Step 3: Move Top Bag Support away from front wheel assembly.



Step 4: The handle is now free to pull upwards. The handle will naturally unfold as you continue to pull until the handle is completely open.



Step 5: Ensure that the Top Bag Support is moved upwards as far as it can go.



Step 6: Close the fold lever to lock the handle into place.

Step 7: Push the Top Bag support down to move it into position.

Please note that the handle can only be locked into one position – it is not height adjustable.

3.4 Folding



Step 1: Disconnect the battery. It can left on or removed from the buggy.



Step 2: Open the fold lever to release the handle.



Step 3: Pull up the latch at the bottom of the handle.



Step 4: Lower the handle down flat.



Step 5: Move the Top Bag Support down so that it locks over the front wheel assembly.



Step 6: Close the fold lever to lock the handle into place.

3.5 Fourth Foldable Rear Wheel

The MGI Zip Navigator comes standard with a fourth foldable and extendable rear wheel. This wheel **MUST** be unfolded and extended into position at all times when the buggy is in use. This will reduce damaging the buggy, and provide the ultimate in stability across all terrains. This fourth wheel should be cleaned regularly with a cloth to ensure it can be folded and retracted as required for storage.



3.6 GPS Holder and Top Handle Compartment

In the top handle compartment there is a position for a GPS/mobile device holder. Open the compartment and connect the holder into position. To open the holder always press the button at the top of the holder. Place the GPS into the cradle, then close the holder by squeezing the two sides closer together.



3.7 Inverting Rear wheels

The rear wheels can be inverted on the axle to reduce the size of the buggy when folded.



4.0 Battery Charging & Connection

The MGI Zip Navigator can only be used with the:
MGI 24v 380Wh Lithium battery

4.1 Initial Charge

Before using your MGI ZIP buggy for the first time you must fully charge the battery overnight.
Plug the charger AC lead into a power point - the Green LED illuminates to indicate the charger is power on.
Plug the charger output connection into the connector on the front of the battery - the Red LED illuminates to indicate charging.
When the charging LED indicator has turned green, the battery is fully charged and ready to be used.



Please refer to the battery charger user manual for further information.

4.2 Connecting the Battery onto the Buggy

Position the battery on the buggy and push the battery down to secure it.



Push the handle down to connect the battery to the buggy.

Your buggy has been equipped with fail safe battery connection, so the buggy will not move when you connect the battery. Your buggy will only start once the speed control is switched on.

4.3 Charging the Battery after Use

Disconnect the battery by lifting the handle.
The battery can be left on or removed from the buggy for charging.
Plug the charger AC lead into a power point - the Green LED illuminates to indicate the charger is power on.
Plug the charger output connection into the connector on the front of the battery - the Red LED illuminates to indicate charging.
When the charging LED indicator has turned green, the battery is fully charged and ready to be used.

5.0 Fitting the Golf Bag

Ensure that the top bag support straps are disconnected.
Position the golf bag on the buggy.

Secure the top bag support strap

Select a good position for the elasticised straps to be put around the golf bag

Stretch the longer end of the strap and loop the rounded plastic bar underneath the hook on the shorter end
The top bag support straps should now be connected.

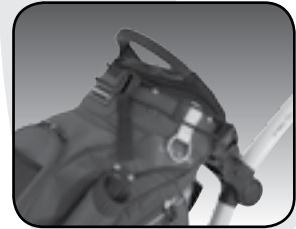

Please ensure the top bag support straps are hooked in place securely before releasing. Failure to do so could result in injury to the user.

Adjusting the length of the top bag support strap

The rounded plastic bar on the longer strap can be adjusted to ensure the bag is secured properly in place.

Secure the lower bag strap

Pull the lower bag strap over the base of the golf bag

6.0 Operating the Digital Top Box

6.1 Top Box Display

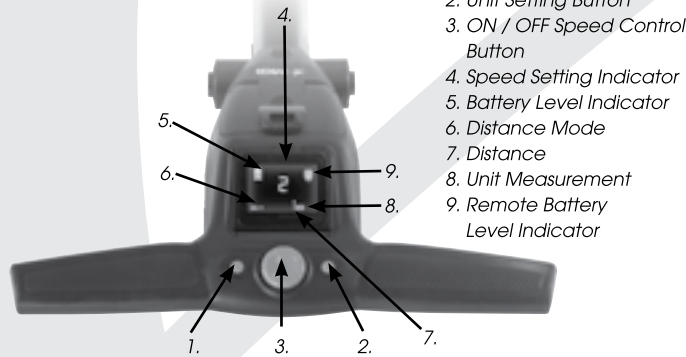

1. Distance Mode Button
2. Unit Setting Button
3. ON / OFF Speed Control Button
4. Speed Setting Indicator
5. Battery Level Indicator
6. Distance Mode
7. Distance
8. Unit Measurement
9. Remote Battery Level Indicator

6.2 Start / Stop the Buggy



ZIP Buggy Speed Control

Please note the following points regarding the ZIP Buggy Speed Control.

1. To select the desired speed, rotate the speed control button. Turning the speed control button clockwise will increase the speed, whilst anti-clockwise will decrease speed.
 2. The speed setting chosen is displayed in the centre of the coloured screen.
- Please note you will feel notches as you rotate the speed control. The notches do not indicate a change in speed. The speed will only increase or decrease as the number changes in the display.*
3. To start the buggy at this desired speed, tap the top of the speed control button.
 4. Another tap will stop the buggy.
 5. The desired speed can be altered up or down while the buggy is moving.

6.3 Turn the Buggy Off

ZIP Buggy Battery

Please note the following points regarding the Zip Buggy Battery.

Connecting the Battery onto the Buggy

1. Position the battery on the buggy and push the battery down to secure it. Push the battery handle down to connect the battery to the buggy.
2. To turn the buggy Top Box Display off: Hold down the Start/Stop Speed Control Button and Left Hand Distance Mode Button for four seconds and the display will turn off thereby disabling the Top Box.

Please note that the battery will still be connected to the buggy and will continue to drain whilst connected.

3. Please note that the buggy display will also turn off if the Speed Control is not operated for 30 minutes.

Once again, please note that the battery will still be connected to the buggy and will continue to drain whilst connected.

4. To reactivate the Top Box Display, whilst the battery is connected, hold down the Start/Stop Speed Control Button and Left Hand Distance Mode Button for four seconds and the display will turn on thereby enabling the Top Box.
5. To fully shut down the buggy and prevent the battery from discharging, disconnect the battery by lifting its handle. The battery can be left on or removed from the buggy.

6.4 Battery Level Indicator

Battery indication is located on the left side of the top box screen. Four coloured bars are highlighted showing full charge. The lesser number of bars displayed, means there is less battery life available. You should always check the battery status before you play golf to ensure the four bars are there.

6.5 Unit Measurements

You can move from meters / kilometres to yards / miles simply by pressing the Unit Setting Button (on the right).

6.6 Distance Modes

There are three distance measurement modes. To move between the modes by pressing the Distance Mode Button (DM) (on the left)

Distance A and B: resettable distance measurements could be used to measure how far you hit your shot and to measure how far you have walked for the day. To reset, simply press the DM Button (left side) for 3 seconds until the reading displays "0". Distance Total: cannot be reset as it is the Odometer for the life of the buggy. This feature will assist with service reminders which are recommended at each 500kms or 6 months periods.

6.7 Competition Mode

In the unlikely event the club you are playing at does not allow the use of distance devices you will need to disable the distances feature on the MGI ZIP buggy.

To disable the distance recording feature, simply hold down the left and right buttons at the same time for 3 seconds and "COMP MODE" will appear on the screen. In addition, the distance recording will be removed from the screen.

To exit COMP MODE hold down the left and right buttons at the same time.



7.0 Remote Control

7.1 Charging Your Remote Control

Before you start using your ZIP Navigator you must fully charge the remote control internal lithium ion battery for approximately 6 hours or overnight using the USB cord provided. The top left UNLOCK button will flash while charging. When a full charge is complete, the green light will stay on and stop flashing.

To charge the remote, plug the USB cord into the USB plug at the base of the remote as pictured in the diagram. The cable then needs to be plugged into your PC or Laptop for charging. Alternatively you can plug the cable into an AC adaptor (not provided).

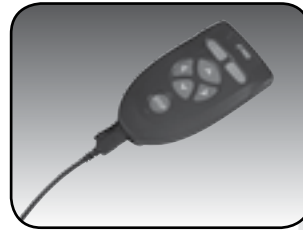

To check the level of power in the remote, use the remote to control to direct the buggy, or at least press a button to talk to the Digital top box and the remote control battery level will show on the screen on the buggy.

The Remote Control will generally need to be charged after six to eight rounds, depending on use.

7.2 Forward Arrow

Press the forward button to start the buggy and accelerate the buggy. The longer you depress the button, the faster the buggy travels.

7.3 Down Arrow

The down arrow decreases the speed and provides for reverse. If you are moving forward, the down arrow can be used to decrease speed, the longer the pressure, the slower the speed. If you continue to press the down button the buggy will go into Reverse mode. If you release the down arrow, whilst the buggy is in Reverse Mode, the buggy will stop (safety feature).

7.4 Left and Right Arrow

When the buggy is stopped, press the appropriate turn command, left or right buttons and keep pressed until the degree of turn is achieved. Then press the forward button for the buggy to go forward.

Whilst the buggy is moving, press the appropriate turn command, left or right buttons and keep pressed until the degree of turn is achieved. Momentary pressure will make a small adjustment to the direction, whilst prolonged pressure will increase the amount of turn and speed of the turn.

7.5 Speed Control – Manually and Remotely

Under manual control, you can adjust the speed by turning the speed control button to the clockwise (Increase) or anti-clockwise (decrease). When changing to the remote control, irrespective of the speed level indicated on the display, the buggy will always start at speed 2.

7.6 Keypad Unlock and Lock

The remote control has two buttons at the top which allow you to LOCK and UNLOCK the keypad. This will help eliminate accidental control when storing the remote in your pocket. The STOP button will continue to work, when the LOCK feature is activated.

7.7 Remote Range and Safety Stop

The ZIP Navigator can be remotely controlled up to 100m. If the remote control loses contact with the buggy, then the automatic safety stop will operate after five seconds. This is for the protection of your buggy, yourself and others. If the buggy was last activated using the manual controls, the auto safety stop feature will not operate. Please note, the top left unlock button will flash every 3 seconds while the buggy is running under remote control.

7.8 Pairing a Remote

If your Remote loses pairing with the Top Box or you replace your Remote it will need to be paired as follows:

- Disconnect the battery
- Hold down the Stop Button on the Remote until both the Lock and Unlock buttons are illuminated – then release the Stop Button.
- Reconnect the battery
- The Remote will synchronise with the Top Box – the process will be complete once the Lock and Unlock buttons are no longer illuminated

Please note, if you do not connect the Navigator, as per point 3, with a battery, the Remote will exit Pairing after one minute.

8.0 Gyroscope Straight Tracker Navigation System

The ZIP Navigator is built with a Patented Gyroscope Straight Tracker Navigation System. This automatic feature ensures the buggy maintains its direction regardless of the terrain. The buggy will automatically brake or accelerate either wheel to maintain its direction.

When the buggy is controlled by the remote, the Navigation system is always ON.

When the buggy is controlled manually, the Navigation system is always OFF.

Tip: On a steep incline, the gradient may force the buggy off line. You do not need to adjust the buggy. The buggy will work its way back on course. In addition, if the buggy hits a divot or other object, the buggy will momentarily be forced off course. Do not be concerned, the buggy knows where to go and will get back on track quickly.

9.0 Warranty

9.1 Warranty Policy

The MGI ZIP buggy is covered by a Limited* manufacturer's warranty from the date of purchase. Duration of this warranty is:

- 2 years on parts*
- 2 years on Lithium batteries and chargers

*MGI or an authorised service centre will repair or replace any parts found to be defective in materials or workmanship under normal use provided that:

- The MGI ZIP buggy has been properly used, maintained and regularly serviced (see section 10.5)
- The replacement or repair is performed by an authorised MGI service centre or the owner with MGI approval.
- The buggy has been registered online.

9.2 Warranty Exclusions

The following events will void warranty:

- Any alteration performed by non-authorised people or companies.
- Fitting of parts or accessories not recommended by MGI.
- Any damage caused by continued operation of the motorised buggy after it is known to be defective.
- Damage to seat and/or seat support bracket on buggy
- Damage caused by ingress of water into motor/gearbox and other major components
- Damage caused by buggy going into bunkers and other course hazards
- All implied warranties (save those preserved by statute) are excluded. Liability for consequential damages under any and all warranties are excluded to the extent exclusion is permitted by law.

9.3 Parts Installed During Warranty

Warranty coverage for components installed during a motorised buggy's warranty period shall consist of the duration of the buggy's warranty period, provided the warranty installation is performed by MGI, an authorised service centre or the buggy owner on approval. Replacement of parts under warranty will not extend the warranty of the buggy or parts.

10.0 Preventative Maintenance Program

To properly provide for the continued operation of your MGI ZIP buggy, MGI has introduced its Preventative Maintenance Program (PMP). The PMP consists of work to be carried out by both the owner and authorised service centres. To properly maintain the warranty of your MGI motorised buggy, it is essential that this work is carried out. If the work carried out by the authorised service centre is to replace parts that are part of the maintenance schedule, the owner will be charged for the parts and labour. If the work to be carried out is part of warranty, MGI will bear the cost.

10.1 Cleaning Your MGI ZIP Buggy (See Maintenance Schedule)

For years of good operation, your buggy requires care and attention.

Keep your buggy clean by using a cloth with warm water and a mild detergent.

Do not hose down your buggy under any circumstance, as the buggy has electronic components.

Ensure that the seat stem bracket is free from sand.

Do not submerge your buggy in water as it will cause irreparable damage.

Clean the buggy battery base when the battery is removed from the buggy.

10.2 Rear Wheel Axles Maintenance (See Maintenance Schedule)

The rear wheel stub axles need to be lubricated regularly. Remove the rear wheels by depressing the spring clip and at the same time pull off the wheel. Apply Petroleum Jelly or light grease to the stub axles. Use a very small amount as the grease can attract sand. If you play in sandy conditions you should clean the axle and regrease fortnightly.

10.3 Upper and Lower Bag Strap Maintenance (See Maintenance Schedule)

The bag straps should be replaced as per the Service Schedule. The upper bag strap can be replaced by:

Removing the left and right hand straps from the upper bag support

Undo and remove the screws holding the strap in position on the bag support

Remove and replace both bag straps

Insert bag strap securing screws.

10.4 Correcting the Alignment

Please see Zip Navigator Motor Trimming on the www.mgigolf.com website.

10.5 MGI Service Schedule

It is the owner's responsibility to ensure that all periodical checks, necessary adjustments and services are carried out. If in doubt please contact the MGI service centre on 1300 644 523. Any work performed on your buggy should be recorded on your service record (see page 21) regardless of the work.

MGI ZIP Navigator	Monthly	6 Monthly	Every 2 yrs	Every 3 yrs
Wipe down the buggy with a warm cloth after each use (do not hose)	BO			
Lubricate rear wheel stub axles	BO			
Check and tighten nuts and bolts		BO		
Check and tighten handle pivots		BO		
Check alignment of buggy – ensure that it runs straight		BO		
Replace Speed Controller and On/Off switch assembly				BO /SC
Replace rear and front wheels				BO
Replace upper and lower bag straps				BO

BO = Buggy owner can carry out this work
 SC = Charged work to be carried by approved service centre
 BO/SC = The six monthly service can be completed by either an authorised service centre or the owner of the buggy.

10.6 Service Record for All Buggies

6 month inspection	Date: Invoice #:	Serviced by: Signature:
1 year inspection	Date: Invoice #:	Serviced by: Signature:
1 ½ year inspection	Date: Invoice #:	Serviced by: Signature:
2 year inspection	Date: Invoice #:	Serviced by: Signature:
2 ½ year inspection	Date: Invoice #:	Serviced by: Signature:
3 year inspection	Date: Invoice #:	Serviced by: Signature:
3 ½ year inspection	Date: Invoice #:	Serviced by: Signature:
4 year inspection	Date: Invoice #:	Serviced by: Signature:
4 ½ year inspection	Date: Invoice #:	Serviced by: Signature:
5 year inspection	Date: Invoice #:	Serviced by: Signature:
5 ½ year inspection	Date: Invoice #:	Serviced by: Signature:
6 year inspection	Date: Invoice #:	Serviced by: Signature:

11.0 Service and Repair Centres

For all servicing, please do not go back to your place of purchase.

MGI offers the largest network of Service Centres in Australia and New Zealand. To find your nearest Service centre visit www.mgigolf.com

For warranty repairs to be authorised you MUST provide proof of purchase. Please keep this with you as well as your Serial number you can record in this manual. It is most important you register your MGI Buggy online for warranty purposes.

12.0 Purchasing Parts and Accessories

You are welcome to service your buggy out of warranty, by purchasing parts direct from MGI. Please call or email to discuss the right parts and instructions.

13.0 Contacting MGI

MGI Golf Head Office

Address:

11 Maurice Court, Nunawading VIC Australia 3131

Phone: + 61 3 8872 6700

Local Toll Free: 1300 644 523 (excludes mobiles)

Email: sales@mgigolf.com **Web:** www.mgigolf.com

14.0 Contacting Local Agent

Please refer to www.mgigolf.com to find the distributor in your country.

15.0 FAQ

Q: My buggy is not tracking straight.

A: Please see Zip Navigator Motor Trimming on the www.mgigolf.com website

Q: I would like to have my MGI buggy serviced. Who do I call?

A: Visit www.mgigolf.com to find your nearest Service Centre using your postcode within Australian and New Zealand. You can also call MGI Head office using any of the contact details. See Section 13.0 for details. Internationals please call your local agent as per Section 14.0

zip SERIES



www.mgigolf.com

MGI Head Office

11 Maurice Court
Nunawading Victoria Australia 3131

Toll Free: 1300 644 523 **P:** +61 3 8872 6700
F: +61 3 9873 1433 **E:** sales@mgigolf.com

International

P: +61 3 8872 6700 **F:** +61 3 9873 1433
E: international@mgigolf.com

Follow us on



Absolute attention has been taken to ensure this manual is correct at time of printing. Specifications, images and statistics may change at any time.

Visit www.mgigolf.com for the most current model information. Printed March 2018. Version 1.3