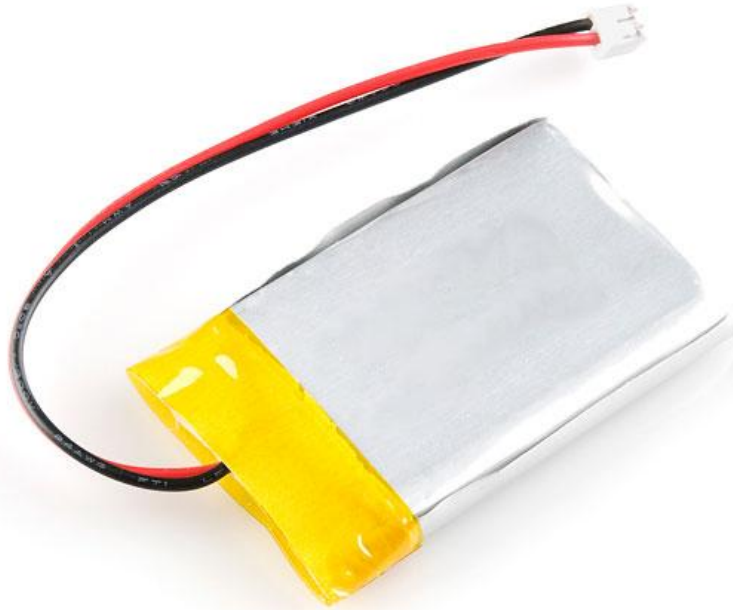

Li-ion Polymer Battery (110mAh) SpecificationSKU: 0939 - www.canadarobotix.com/products/939

(generic photo used, actual product may be larger or smaller)

Limit of Liability/Disclaimer of Warranty: THE AUTHOR MAKES NO REPRESENTATIONS OR WARRANTIES WITH RESPECT TO THE ACCURACY OR COMPLETENESS OF THE CONTENTS OF THIS WORK AND SPECIFICALLY DISCLAIMS ALL WARRANTIES, INCLUDING WITHOUT LIMITATION WARRANTIES OF FITNESS FOR A PARTICULAR PURPOSE. NO WARRANTY MAY BE CREATED OR EXTENDED BY SALES OR PROMOTIONAL MATERIALS. THE ADVICE AND STRATEGIES CONTAINED HEREIN MAY NOT BE SUITABLE FOR EVERY SITUATION. IF PROFESSIONAL ASSISTANCE IS REQUIRED, THE SERVICES OF A COMPETENT PROFESSIONAL PERSON SHOULD BE SOUGHT. THE AUTHOR SHALL NOT BE LIABLE FOR LOSS OR DAMAGES ARISING HEREFROM, WHETHER BASED ON CONTRACT, WARRANTY, TORT (INCLUDING NEGLIGENCE AND FOR PROPERTY DAMAGE AND DEATH) OR OTHER GROUNDS. THE FACT THAT AN ORGANIZATION OR WEBSITE IS REFERRED TO IN THIS WORK AS A CITATION AND/OR A POTENTIAL SOURCE OF FURTHER INFORMATION DOES NOT MEAN THAT THE AUTHOR ENDORSES THE INFORMATION THE ORGANIZATION OR WEBSITE MAY PROVIDE OR RECOMMENDATIONS IT MAY MAKE. FURTHER, READERS SHOULD BE AWARE THAT INTERNET WEBSITES LISTED IN THIS WORK MAY HAVE CHANGED OR DISAPPEARED BETWEEN WHEN THIS WORK WAS WRITTEN AND WHEN IT IS READ. **BY USING THIS PRODUCT, YOU AGREE TO BE BOUND BY AND ACCEPT THESE TERMS AND CONDITIONS.**

- **Lithium batteries are a fire hazard.** They must be charged and stored in a fire proof area. We recommend charging them on concrete a safe distance from any flammable materials. Read and understand the instructions included with your Lithium battery charger before attempting to charge Lithium batteries.
- **Use Lithium Polymer specific charger only. DO NOT use a NiMH or NiCd charger.** Failure to do so may cause fire, which may result in personal injury and property damage.
- **Never charge batteries unattended.** When charging Lithium batteries you should always remain in constant observation to monitor the charging process and react to potential problems that may occur.
- Some Lithium chargers on the market may have technical deficiencies that may cause it to charge the Lithium batteries incorrectly or at an improper rate. It is your responsibility solely to assure the charger you purchased works properly. Always monitor the charging process to assure batteries are being charged properly. Failure to do so may result in fire.

1. Specification

Table 1

Characteristic	Parameter	Note
Rated Capacity	Typical: 110mAh Minimum: 100mAh	0.5C ₅ A discharge
Nominal Voltage	3.7V	Mean Operating Voltage
Voltage at Fully Discharge	2.35V	Discharge cut-off voltage
Charging Voltage	4.2±0.03V	
Internal Impedance	≤300mΩ	Internal resistance measured at AC 1kHz at 50% charge
Standard charge	Constant current: 0.2C ₅ A Constant voltage: 4.2V 0.01C ₅ A cut-off	22mA Charge time: Approx 6.0h
Standard discharge	Constant current: 0.5C ₅ A end voltage: 2.35V	55mA
Fast charge	Constant current: 1C ₅ A Constant voltage: 4.2V 0.01C ₅ A cut-off	110mA Charge time: Approx 1.5h
Fast discharge	Constant current: 1C ₅ A end voltage: 2.35V	110mA

Maximum Continuous Charge Current	1C ₅ A	110mA
Maximum Continuous Discharge Current	1C ₅ A	110mA
Operating Temperature Range	Charge: 0-45°C Discharge: -10-50°C	60±25% RH
Storage Temperature Range	< 1 year: -10-25°C < 3 months: -10-40°C	60±25% RH

2. Materials

Table 2

Cell case	ON-AL-CPP film / 0.113mm
Anode	Carbon fiber
Cathode	Lithium Cobalt Oxide, LiCoO ₂
Electrolyte	EC / DMC / EMC / LiPF ₆
Separator	Polyethylene / 20µm

3. Performance And Test Conditions

3.1. Standard Test Conditions

Tests should be conducted with new batteries within one week after shipment from our factory and the cells shall not be cycled more than five times before the test. Unless otherwise specified, test and measurement shall be done under temperature of 20±5°C and relative humidity of 45~85%. If it is judged that the test results are not affected by such conditions, the tests may be conducted at temperature 15~30°C and humidity 25~85%RH.

3.2. Measuring Instrument or Apparatus

3.2.1. Dimension Measuring Instrument

The dimension measurement shall be implemented by instruments with equal or more precision scale of 0.01mm.

3.2.2. Voltmeter

Standard class specified in the national standard or more sensitive class having inner impedance more than 10kΩ/V

3.2.3. Ammeter

Standard class specified in the national standard or more sensitive class.
Total external resistance including ammeter and wire is less than 0.01Ω.

3.2.4. Impedance Meter

Impedance shall be measured by a sinusoidal alternating current method (1kHz LCR meter).

3.3. Standard Charge\Discharge

3.3.1. Standard Charge: $0.2C_5A = 22mA$

Charging shall consist of charging at a $0.2C_5A$ constant current rate until the cell reaches 4.2V. The cell shall then be charged at constant voltage of 4.2 volts while tapering the charge current. Charging shall be terminated when the charging current has tapered to $0.01C_5A$. Charge time : Approx 6.0h, The cell shall demonstrate no permanent degradation when charged between 0°C and 45°C.

3.3.2. Standard Discharge: $0.5C_5A = 55mA$

Cells shall be discharged at a constant current of $0.5C_5A$ to 2.35 volts @ $20 \pm 5^\circ C$

3.3.3. If not otherwise specified, the rest time between Charge and Discharge shall be 30min.

3.4. Appearance

There shall be no such defect as flaw, crack, rust, leakage, which may adversely affect commercial value of battery.

3.5. Initial Performance Test

Table 3

Characteristic	Test Method and Condition	Requirements
(1) Open-Circuit Voltage	The open-circuit voltage shall be measured within 24 hours after standard charge.	$\geq 4.08V$
(2) Internal impedance	Internal resistance measured at AC 1KHz after 50% charge.	$\leq 300m\Omega$
(3) Minimal Rated Capacity	The capacity on $0.5C_5A$ discharge till the voltage tapered to 2.35V shall be	$\geq 100mAh$

	measured after resting for 30min then finishing standard charge.	
--	--	--

3.6. Temperature Dependence of Discharge Capacity

Cells shall be charged per 3.3.1 and discharged @0.5C₅A to 2.3V. Except to be discharged at temperatures per Table 4. Cells shall be stored for 3 hours at the test temperature prior to discharging and then shall be discharged at the test temperature. The capacity of a cell at each temperature shall be compared to the capacity achieved at 23°C and the percentage shall be calculated. Each cell shall meet or exceed the requirements of Table 4.

Table 4

Discharge Temperature	-10°C	0°C	23°C	50°C
Discharge Capacity (0.2C ₅ A)	50%	80%	100%	95%

3.7. Cycle Life and Leakage-Proof

Table 5

Characteristic	Criteria	Test Condition
Cycle Life (0.5C ₅ A)	Higher than 80% of the Initial Capacities of the Cells	Carry out 500cycle Charging/Discharging in the below condition. <ul style="list-style-type: none"> ● Charge: Standard Charge, per 3.3.1 ● Discharge: 0.5C₅A to 2.35 V ● Rest Time between charge/discharge: 30min ● Temperature: 20±5°C
Leakage-Proof	No leakage (visual inspection)	After full charge with standard charge, store at 60±3°C and 60±10%RH for 1 month.

4. Mechanical characteristics and Safety Test

Table 6

Test	Battery Condition	Test Method	Requirements
Vibration Test	Fresh, Fully charged	After standard charging, fixed the cell to vibration table and subjected to vibration cycling that the frequency is to be varied at the rate of 1Hz per minute between 10Hz an 55Hz, the excursion of the vibration is 1.6mm. The cell shall be vibrated for 30 minutes per axis of XYZ axes.	No leakage No fire
Drop Test	Fresh, Fully charged	The cell is to be dropped from a height of 1 meter twice onto concrete ground.	No explosion No leakage No fire
Crush	Fresh, Fully charged	Crush between two flat plates. Applied force is about 13kN (1.72Mpa) for 30min.	No explosion No fire
Short Circuit	Fresh, Fully charged	Each test sample battery, in turn, is to be short-circuited by connecting the (+) and (-) terminals of the battery with a copper wire having a maximum resistance load of 0.1Ω. Tests are to be conducted at room temperature (20±2°C).	No explosion No fire The temperature of the surface of the Cells are lower than 150°C
Over Charge	Fresh, Fully charged	a) Charge the battery according to 2.6, and leave it for 24 hours. b) Connect the positive and negative terminals of the cell with a constant power, turn the current to 3.0C ₅ A, and the voltage to 4.8V, charge the cell with 3.0C ₅ A, the test will end when the current drops down to 0A. Watch the temperature of the cell, end the test when the temperature is 10°C below the peak	No explosion No rupture No fire
Impact	Fresh, Fully charged	A 56mm diameter bar is inlayed into the bottom of a 10kg weight. And the weight is to be dropped from a height of 1m onto a sample battery and then the bar will be across the center of the sample.	No explosion No fire

Forced Discharge	Fresh, Fully charged	Discharge at a current of 1C ₅ A for 2.5h.	No explosion No fire
Nail Pricking	Fresh, Fully charged	Prick through the sample battery with a nail having a diameter of 3mm and remain 2h.	No explosion No fire

5. Handling of Cells

5.1. Consideration of strength of film package

5.1.1. Soft aluminum foil

Easily damaged by sharp edge parts such as pins and needles, Ni-tabs, compared with metal-can-cased LIB.

5.1.2. Sealed edges may be damaged by heat above 100°C, bend or fold.

5.2. Prohibition of short circuit

Never short circuit the battery cell. It generates very high current which causes heating of the cells and may cause electrolyte leakage, gassing or explosion that are very dangerous. The LIP tabs may be easily short-circuited by putting them on conductive surfaces. Such an outer short circuit may lead to heat generation and damage of the cell. An appropriate circuitry with PCM shall be employed to protect accidental short circuiting of the battery pack.

5.3. Mechanical shock

LIP cells have less mechanical endurance than metal-can-cased LIB. Falling, hitting, bending, etc. may cause degradation of LIP characteristics.

5.4. Handling of tabs

The battery tabs are fragile especially for aluminum tabs. Don't bend the tabs.

6. Notice for Designing Battery Pack**6.1. Pack toughness**

Battery pack should have sufficient strength and the LIP cell inside should be protected from mechanical shocks.

6.2. Cell fixing

The LIP cell should be fixed to the battery pack by its large surface area. No cell movement in the battery pack should be allowed.

6.3. Inside design

No sharp edge components should be inside the pack containing the LIP cell.

6.4. Tab connection

Ultrasonic welding or spot welding is recommended for the LIP tab connection method. Battery packs should be designed so that shear forces are not applied to the LIP tabs.

If apply manual solder method to connect tab with PCM, below notice is very important to ensure battery performance:

- The solder iron should be temperature controlled and ESD safe;
- Soldering temperature should not exceed 350°C;
- Soldering time should not be longer than 3s;
- Soldering times should not exceed 5 times, Keep battery tab cold down before next time soldering;
- Directly heat cell body is strictly prohibited, Battery may be damaged by heat above approx. 80°C

6.5. For mishaps

Battery packs should be designed not to generate heat even when leakage occurs due to mishaps.

6.5.1. Isolate PCM (Protection Circuit Module) from leaked electrolyte as perfectly as possible.

6.5.2. Avoid narrow spacing between bare circuit patterns with different voltages. (Including around connector)

6.5.3. LIP batteries should not have liquid from electrolyte, but in case If leaked electrolytes touch bare circuit patterns, higher potential terminal material may dissolve and precipitate at the lower potential terminal, and may cause short circuit. The design of the PCM must have this covered.

7. Notice for Assembling Battery Pack

Shocks, high temperature, or contacts of sharp edge components should not be allowed in battery pack assembling process.

8. Others

8.1. Cell connection

8.1.1. Direct soldering of wire leads or devices to the cell is strictly prohibited.

8.1.2. Lead tabs with pre-soldered wiring shall be spot welded to the cells.

Direct soldering may cause damage to components, such as separators and insulators, by heat generation.

8.2. Prevention of short circuit within a battery pack

Enough insulation layers between wiring and the cells shall be used to maintain extra safety protection. The battery pack shall be structured with no short circuit within the battery pack, which may cause generation of smoke or firing.

8.3. Prohibition of dis-assembly

8.3.1. Never disassemble the cells

The disassembling may generate an internal short circuit in the cell, which may cause gassing, firing, explosion, or other problems.

8.3.2. Electrolyte is harmful

LIP batteries should not have liquid from electrolyte flowing, but in case the electrolyte comes into contact with the skin, or eyes, physicians shall flush the electrolyte immediately with fresh water and medical advice is to be sought.

8.4. Prohibition of dumping of cells into fire

Never incinerate nor dispose of the cells in fire. These may cause explosion of the cells, which is very dangerous and is prohibited.

8.5. Prohibition of cells immersion into liquid such as water

The cells shall never be soaked with liquids such as water, seawater, drinks such as soft drinks, juices, coffee or others.

8.6. Battery replacement

The battery replacement shall be done only by either cell supplier or device supplier and never be done by the user.

8.7. Prohibition of use of damaged cells

The cells might be damaged during shipping by shock. If any abnormal features of the cells are found such as damages in a plastic envelope of the cell, deformation of the cell package, smelling of an electrolyte, an electrolyte leakage and others, the cells shall never be used any more. The Cells with a smell of the electrolyte or a leakage shall be placed away from fire to avoid firing or explosion.

9. Period of Warranty

The period of warranty is half a year from the date of shipment. We guarantee to give a replacement in case of cells with defects proven due to the manufacturing process instead of the customer abuse and misuse.

10. Storing the Batteries

The batteries should be stored at room temperature, charged to about 30% to 50% of capacity. We recommend that batteries be charged about once per half a year to prevent over discharge.

11. Other The Chemical Reaction

Because batteries utilize a chemical reaction, battery performance will deteriorate over time even if stored for a long period of time without being used. In addition, if the various usage conditions such as charge, discharge, ambient temperature, etc. are not maintained within the specified ranges the life expectancy of the battery may be shortened or the device in which the battery is used may be damaged by electrolyte leakage. If the batteries cannot maintain a charge for long periods of time, even when they are charged correctly, this may indicate it is time to change the battery.

12. Note

Any other items which are not covered in this specification shall be agreed by both parties.

13. Charge-discharge Curves

Charging Curves

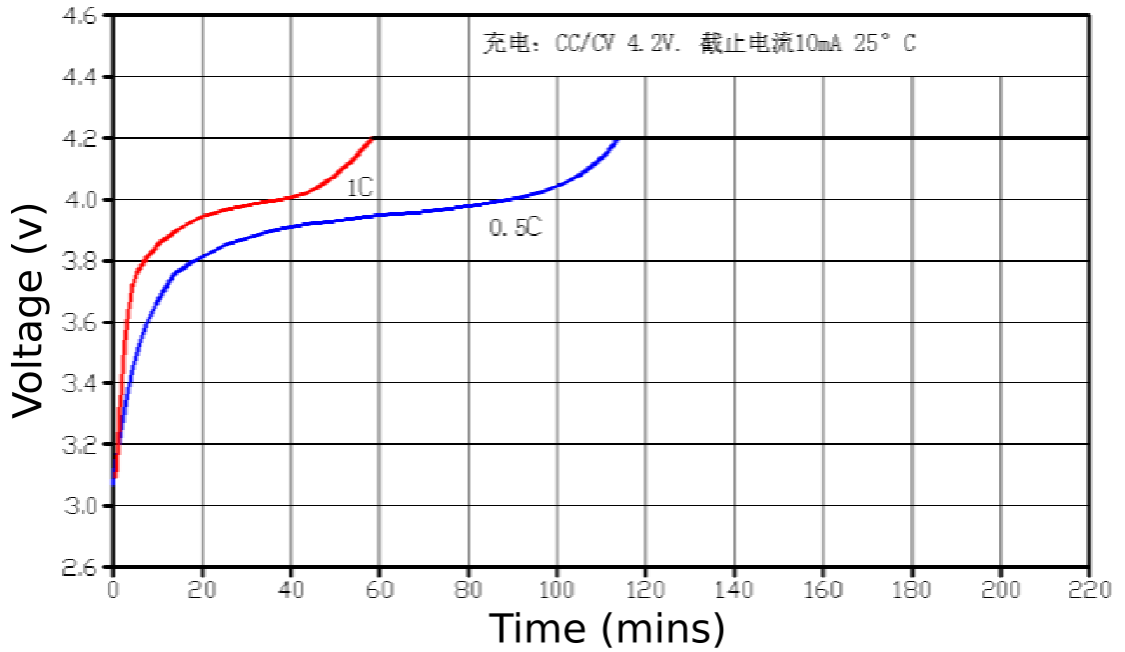

Discharge Curves at Various Discharge Rates

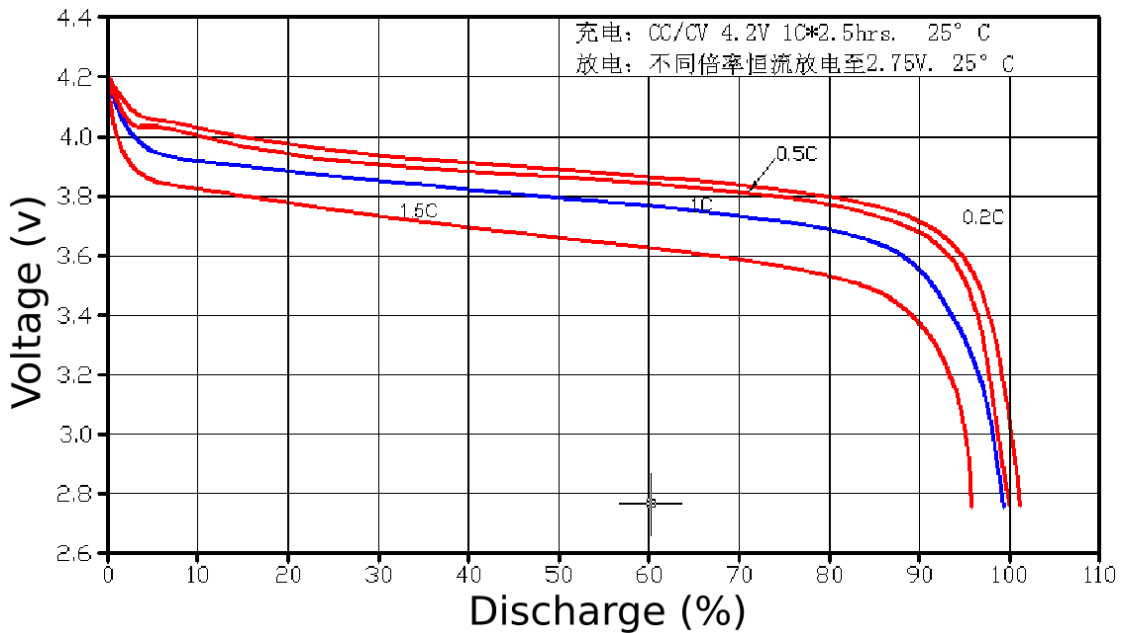

Discharge Curves at Various Temperatures

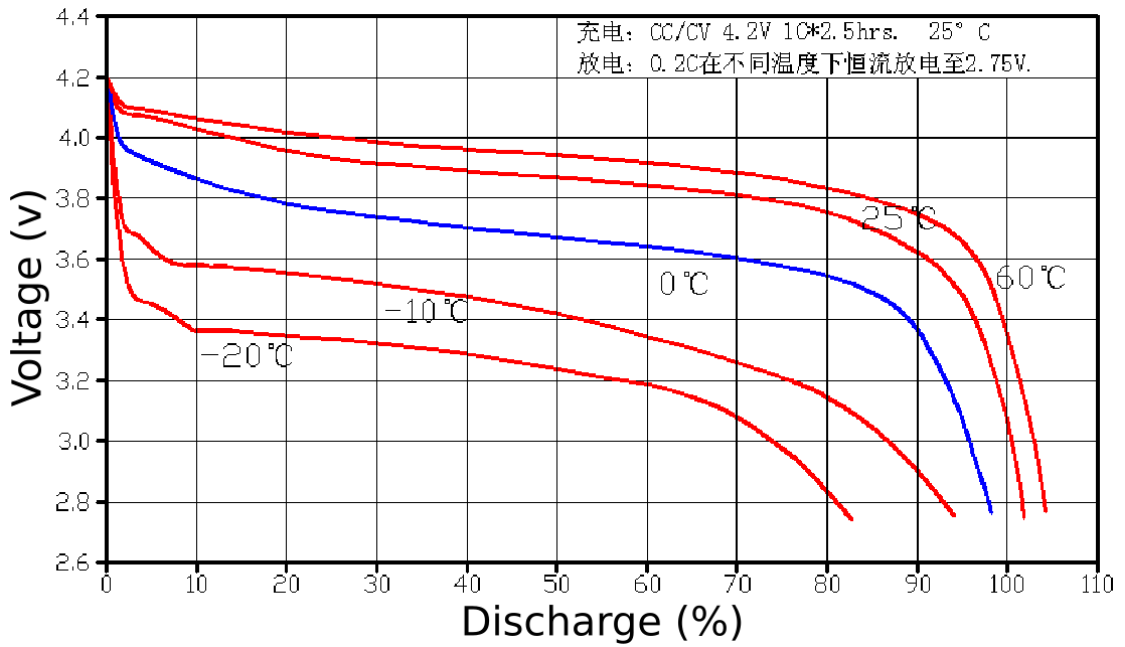

Battery Capacity vs Charge-Discharge Cycle

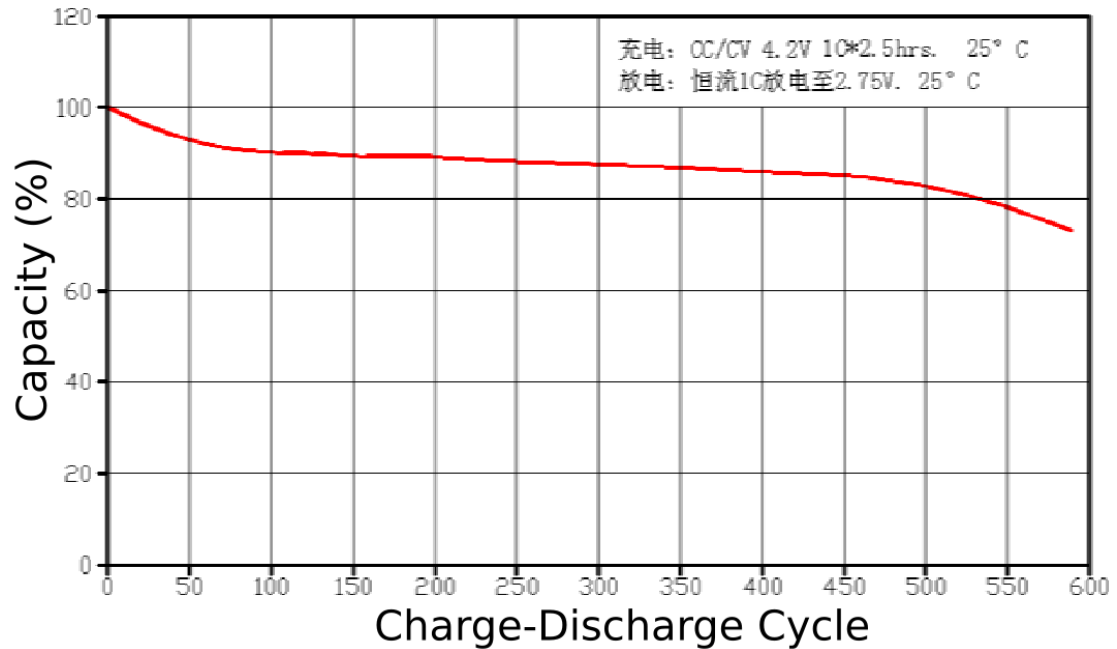

14. Cell Dimension

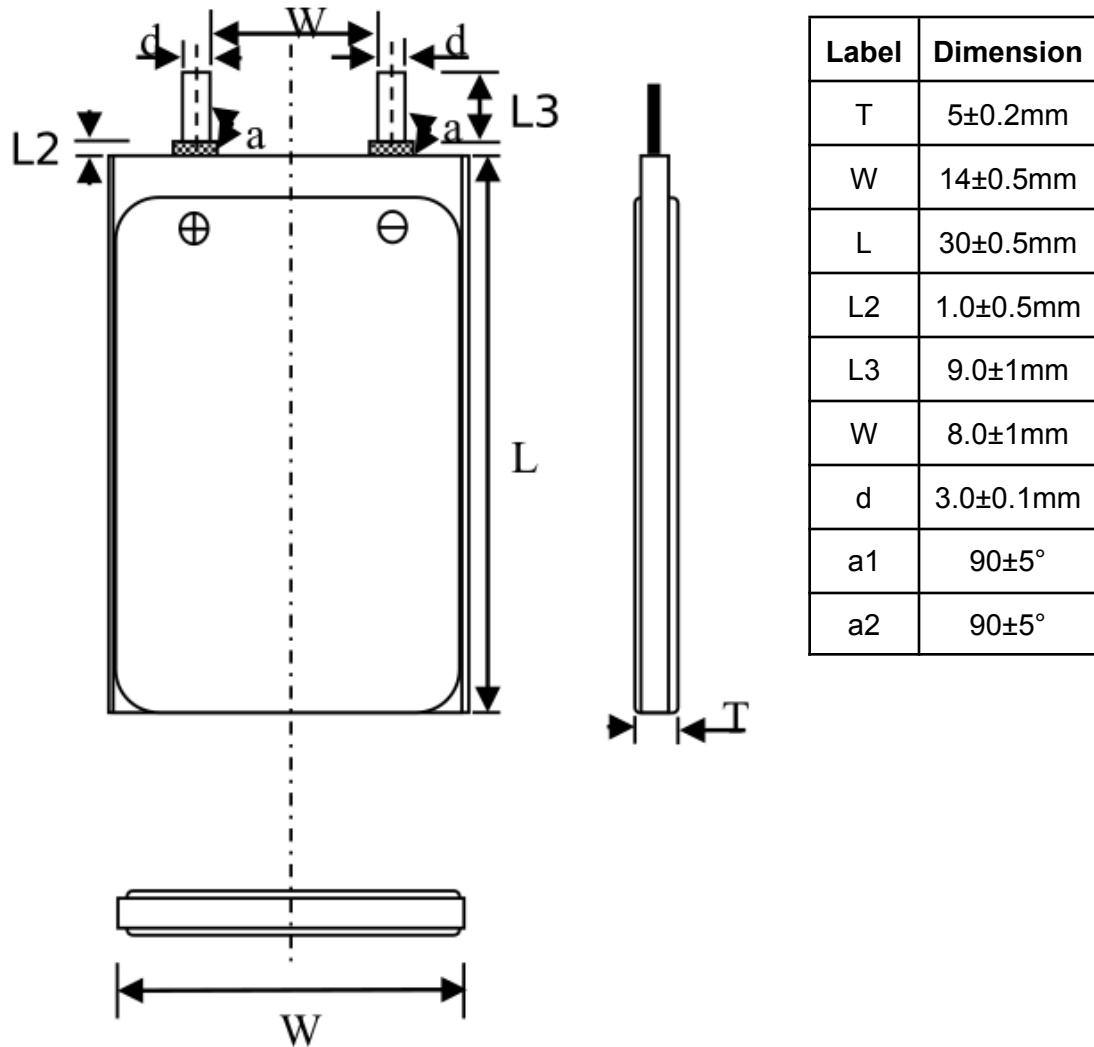

15. Typical Application Schematic Diagram of PCB

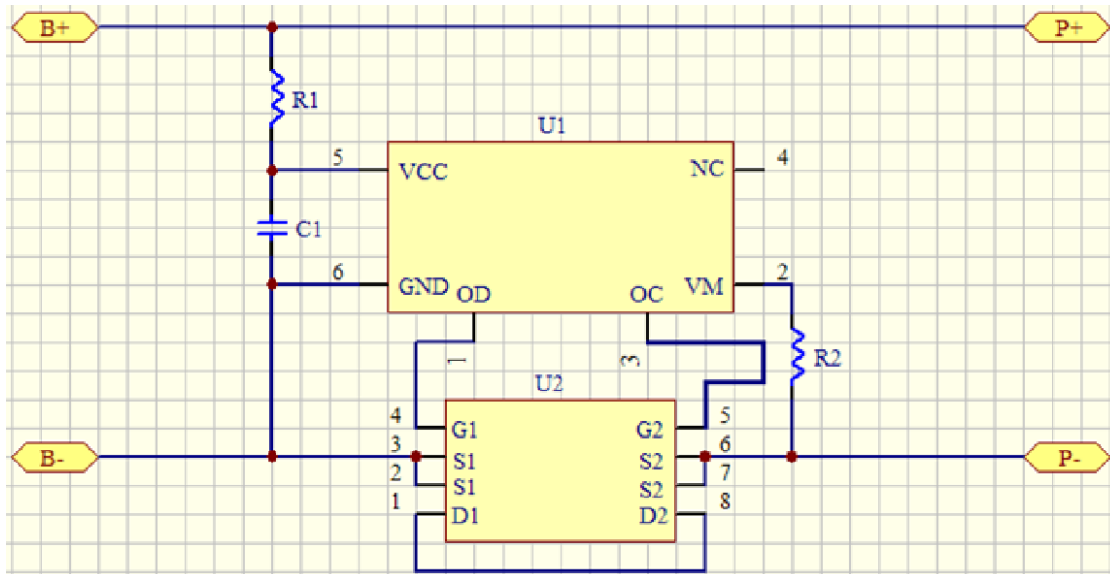

16. Parts List

Description	Symbol	Spec	Qty
Resistor	R1	100Ω, 0603	1
Capacitor	C1	0.1μF, 0603	1
Resistor	R2	1kΩ, 0603	1
IC	U1	SOT-23-6	1
MOS	U2	TSSOP-8	1
Nickel Plate	B+, B-	8x3x0.3mm	2

17. External Dimension Drawing

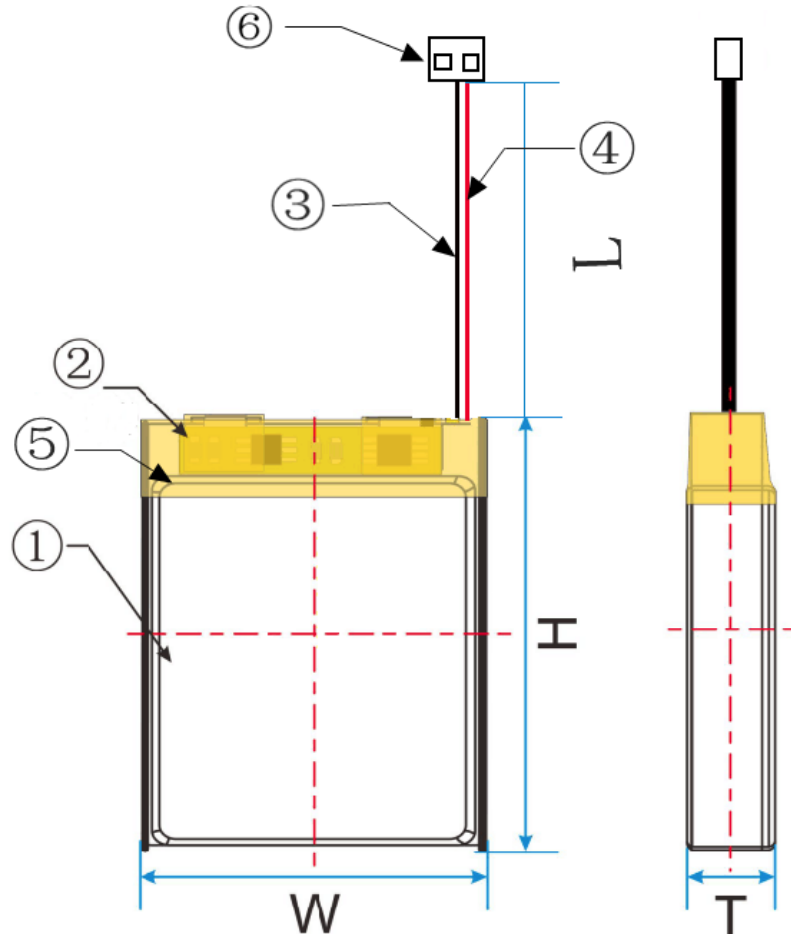

External Dimension:

Thickness	$T = 5.5 \pm 0.3 \text{mm}$
Width	$W = 14 \pm 0.5 \text{mm}$
Height	$H = 32 \pm 0.5 \text{mm}$
Wire Length	$L = 100 \pm 3 \text{mm}$

Assembly:

1	Battery Cell
2	PCM
3	Black Wire (-)
4	Red Wire (+)
5	Insulating Tape
6	Connector, PH-2P, reverse direction