

TEST REPORT

Report Number..... : **ZKT-2104061094E-2**

Date of Test..... Apr. 08, 2021 to Apr. 13, 2021

Date of issue..... : Apr. 13, 2021

Total number of pages..... 41

Test Result : PASS

Testing Laboratory..... : **Shenzhen ZKT Technology Co., Ltd.**

Address : 1/F, No. 101, Building B, No. 6, Tangwei Community Industrial Avenue, Fuhai Street, Bao'an District, Shenzhen, China

Applicant's name : **Elitech Technology, Inc.**

Address : 2528 Qume Dr, Ste 2 San Jose, CA 95131.

Manufacturer's name : **Jiangsu Jingchuang Electronics Co.,Ltd.**

Address : No.21 Zhujiang East Road, 3rd Industrial Park, High-tech Industrial Development Zone, Xuzhou, Jiangsu, China

Test specification:

Standard..... : ETSI EN 301 489-1 V2.2.3 (2019-11)
ETSI EN 301 489-17 V3.2.4 (2020-09)

Test procedure..... : /

Non-standard test method : N/A

This device described above has been tested by ZKT, and the test results show that the equipment under test (EUT) is in compliance with the 2014/53/EU RED Directive Art.3.1(b) requirements. And it is applicable only to the tested sample identified in the report.

This report shall not be reproduced except in full, without the written approval of ZKT, this document may be altered or revised by ZKT, personal only, and shall be noted in the revision of the document.

Product name..... : manifold gauge

Trademark : N/A

Model/Type reference..... : EMG-40V
MS-1000, MS-1000S, MS-2000, MS-2000S, MS-3000, MS-3000S,
MS-4000, MS-4000S, EMG-10V, EMG-10VW, EMG-20V,
EMG-20VW, EMG-30V, EMG-30VW, EMG-40V, EMG-40VW

Ratings..... : Input: 5V \pm 2A,
DC3.7V 5000mAh by battery

Testing procedure and testing location:

Testing Laboratory.....: **Shenzhen ZKT Technology Co., Ltd.**

Address.....: 1/F, No. 101, Building B, No. 6, Tangwei Community
Industrial Avenue, Fuhai Street, Bao'an District,
Shenzhen, China

Tested by (name + signature).....: Alen He

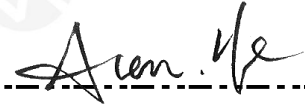

Reviewer (name + signature).....: Joe Liu

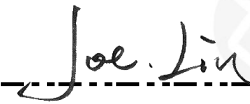

Approved (name + signature).....: Lake Xie



TABLE OF CONTENT

	Page
1. Version.....	5
2. TEST SUMMARY.....	6
3. MEASUREMENT UNCERTAINTY.....	7
3.1 TEST FACILITY.....	7
3.2 MEASUREMENT UNCERTAINTY.....	7
4. GENERAL INFORMATION.....	8
4.1. GENERAL DESCRIPTION OF EUT.....	8
4.2. DESCRIPTION OF TEST MODES.....	8
4.3. DESCRIPTION OF TEST SETUP.....	8
4.4. DESCRIPTION TEST PERIPHERAL AND EUT PERIPHERAL.....	9
4.5. MEASUREMENT INSTRUMENTS LIST.....	10
5. EMC EMISSION TEST.....	12
5.1. CONDUCTED EMISSION MEASUREMENT.....	12
5.1.1. POWER LINE CONDUCTED EMISSION.....	12
5.1.2. TEST PROCEDURE.....	13
5.1.3. TEST SETUP.....	13
5.1.4. EUT OPERATING CONDITIONS.....	13
5.1.5. TEST RESULTS.....	13
5.2. RADIATED EMISSION MEASUREMENT.....	14
5.2.1. LIMITS OF RADIATED EMISSION MEASUREMENT.....	14
5.2.2. LIMITS OF RADIATED EMISSION MEASUREMENT.....	14
5.2.3. TEST PROCEDURE.....	14
5.2.4. TEST SETUP.....	15
5.2.5. EUT OPERATING CONDITIONS.....	15
5.2.6. TEST RESULTS (30-1000MHz).....	16
5.3. LIMITS OF HARMONICS CURRENT.....	18
5.3.1. TEST PROCEDURE.....	19
5.3.2. EUT OPERATING CONDITIONS.....	19
5.3.3. TEST SETUP.....	19
5.3.4. TEST RESULTS.....	19
5.4. VOLTAGE FLUCTUATION AND FLICKERS.....	20
5.4.1. LIMITS OF VOLTAGE FLUCTUATION AND FLICKERS.....	20
5.4.2 TEST PROCEDURE.....	20
5.4.3 EUT OPERATING CONDITIONS.....	20
5.4.4 TEST SETUP.....	20
5.4.5 TEST RESULTS.....	20
6. EMC IMMUNITY TEST.....	21
6.1. GENERAL PERFORMANCE CRITERIA.....	21
6.2. GENERAL PERFORMANCE CRITERIA TEST SETUP.....	22
7. ESD TESTING.....	23

7.1 TEST SPECIFICATION.....	23
7.2 TEST PROCEDURE.....	23
7.3 TEST SETUP.....	24
7.4 TEST RESULTS.....	25
8. RS TESTING.....	26
8.1 TEST SPECIFICATION.....	26
8.2 TEST PROCEDURE.....	27
8.3 TEST SETUP.....	27
8.4 TEST RESULTS.....	28
9. EFT/BURST TESTING.....	29
9.1 TEST SPECIFICATION.....	29
9.2 TEST PROCEDURE.....	29
9.3 TEST SETUP.....	29
9.4 TEST RESULTS.....	30
10. SURGE TESTING.....	31
10.1 TEST SPECIFICATION.....	31
10.2 TEST PROCEDURE.....	31
10.3 TEST SETUP.....	32
10.4 TEST RESULTS.....	32
11. INJECTION CURRENT TESTING.....	33
11.1 TEST SPECIFICATION.....	33
11.2 TEST PROCEDURE.....	33
11.3 TEST SETUP.....	34
11.4 TEST RESULTS.....	34
12. VOLTAGE INTERRUPTION/DIPS TESTING.....	35
12.1 TEST SPECIFICATION.....	35
12.2 TEST PROCEDURE.....	35
12.3 TEST SETUP.....	35
12.4 TEST RESULTS.....	35
13. PHOTOS OF EUT.....	36
14. PHOTOS OF TEST SETUP.....	41

1. Version

Report No.	Issue Date	Description	Approved
ZKT-2104061094E-2	Apr. 13, 2021	Original	Valid

2. TEST SUMMARY

The Product has been tested according to the following specifications:

EMISSION(EN301489-1,EN301489-17)				
Standard	Test Item	Limit	Judgment	Remark
EN 55032	Conducted Emission	Class B	N/A	
	Radiated Emission	Class B	PASS	
EN 61000-3-2	Harmonic Current Emission	Class A or D NOTE (2)	N/A	
EN 61000-3-3	Voltage Fluctuations & Flicker	--	N/A	
EMC Immunity				
Section EN 55035	Test Item	Performance Criteria	Judgment	Remark
EN 61000-4-2	Electrostatic Discharge	B	PASS	
EN 61000-4-3	RF electromagnetic field	A	PASS	
EN 61000-4-4	Fast transients	B	N/A	
EN 61000-4-5	Surges	B	N/A	
EN 61000-4-6	Injected Current	A	N/A	
EN 61000-4-8	Power Frequency Magnetic Field	A	N/A	
EN 61000-4-11	Volt. Interruptions Volt. Dips	B / C / C NOTE (3)	N/A	

NOTE:

- (1) "N/A" denotes test is not applicable in this Test Report
- (2) The power consumption of EUT is less than 75W and no Limits apply.
- (3) Voltage dip: 100% reduction – Performance Criteria B
 Voltage dip: 30% reduction – Performance Criteria C
 Voltage Interruption: 100% Interruption – Performance Criteria C
- (4) For client's request and manual description, the test will not be executed.

3. MEASUREMENT UNCERTAINTY

3.1 TEST FACILITY

Shenzhen ZKT Technology Co., Ltd.
Add.: ZKT Building & 1/F, No. 101, Building B, No. 6, Tangwei Community Industrial Avenue, Fuhai Street, Bao'an District, Shenzhen, China
FCC Test Firm Registration Number: 712850
IC Registered No.: 23583

3.2 MEASUREMENT UNCERTAINTY

The reported uncertainty of measurement $y \pm U$ · where expanded uncertainty U is based on a standard uncertainty multiplied by a coverage factor of $k=2$ · providing a level of confidence of approximately 95 % ·

No.	Item	Uncertainty
1	3m chamber Radiated spurious emission(30MHz-1GHz)	U=4.3dB
2	3m chamber Radiated spurious emission(1GHz-18GHz)	U=4.5dB
3	Conducted Emission (150kHz-30MHz)	U=3.20dB

4. GENERAL INFORMATION

4.1. GENERAL DESCRIPTION OF EUT

EUT Name	:	manifold gauge
Model No.	:	EMG-40V
Serial Model	:	MS-1000, MS-1000S, MS-2000, MS-2000S, MS-3000, MS-3000S, MS-4000, MS-4000S, EMG-10V, EMG-10VW, EMG-20V, EMG-20VW, EMG-30V, EMG-30VW, EMG-40V, EMG-40VW
Model Difference	:	Model name and appearance
Trademark	:	N/A
Power supply	:	Input: 5V $\overline{\text{---}}$ 2A, DC3.7V 5000mAh by battery
Operation frequency	:	2402MHz-2480MHz
Modulation	:	GFSK
Antenna Type	:	PCB Antenna, Maximum Gain is 0dBi

Note:

1. For a more detailed features description, please refer to the manufacturer's specifications or the User's Manual.

4.2. DESCRIPTION OF TEST MODES

To investigate the maximum EMI emission characteristics generates from EUT, the test system was pre-scanning tested base on the consideration of following EUT operation mode or test configuration mode which possible have effect on EMI emission level. Each of these EUT operation mode(s) or test configuration mode(s) mentioned above was evaluated respectively.

For all Test Mode	Description
Mode 1	Charging Mode + Communication Mode
Mode 2	Communication Mode

4.3. DESCRIPTION OF TEST SETUP

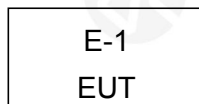

4.4. DESCRIPTION TEST PERIPHERAL AND EUT PERIPHERAL

The EUT has been tested as an independent unit together with other necessary accessories or support units. The following support units or accessories were used to form a representative test configuration during the tests.

Item	Equipment	Mfr/Brand	Model/Type No.	Series No.	Note
E-1	manifold gauge	N/A	EMG-40V	MS-1000, MS-1000S, MS-2000, MS-2000S, MS-3000, MS-3000S, MS-4000, MS-4000S, EMG-10V, EMG-10VW, EMG-20V, EMG-20VW, EMG-30V, EMG-30VW, EMG-40V, EMG-40VW	EUT

Item	Shielded Type	Ferrite Core	Length	Note

Note:

- (1) The support equipment was authorized by Declaration of Confirmation.
- (2) For detachable type I/O cable should be specified the length in cm in 『Length』 column.

4.5. MEASUREMENT INSTRUMENTS LIST
For Conducted Emission at the mains terminals Test

Item	Kind of Equipment	Manufacturer	Type No.	Serial No.	Last calibration	Calibrated until
1	LISN	R&S	ENV216	N/A	Sep. 22, 2020	Sep. 21, 2021
2	LISN	CYBERTEK	EM5040A	N/A	Sep. 22, 2020	Sep. 21, 2021
3	Test Cable	N/A	C01	N/A	Sep. 22, 2020	Sep. 21, 2021
4	Test Cable	N/A	C02	N/A	Sep. 22, 2020	Sep. 21, 2021
5	EMI Test Receiver	R&S	ESCI3	101421	Sep. 22, 2020	Sep. 21, 2021
6	Triple-Loop Antenna	LAPLACE	RF300	9194	Sep. 22, 2020	Sep. 21, 2021
7	Absorbing Clamp	DZ	ZN23201	N/A	Sep. 22, 2020	Sep. 21, 2021

For Radiated Emission Test

Item	Kind of Equipment	Manufacturer	Type No.	Serial No.	Last calibration	Calibrated until
1	Bilog Antenna	Schwarzbeck	VULB9168	N/A	Sep. 22, 2020	Sep. 21, 2021
2	Loop Antenna	SCHWARZBECK	FMZB1519B	014	Sep. 22, 2020	Sep. 21, 2021
3	Test Cable	N/A	R-01	N/A	Sep. 22, 2020	Sep. 21, 2021
4	Test Cable	N/A	R-02	N/A	Sep. 22, 2020	Sep. 21, 2021
5	EMI Test Receiver	R&S	ESCI7	101154	Sep. 22, 2020	Sep. 21, 2021
6	Antenna Mast	EM	SC100_1	N/A	N/A	N/A
7	Turn Table	EM	SC100	N/A	N/A	N/A
8	Spectrum Analyzer	KEYSIGHT	9020A	N/A	Sep. 22, 2020	Sep. 21, 2021
9	Horn Antenna (1GHz-18GHz)	Schwarzbeck	BBHA9120D	1541	Sep. 22, 2020	Sep. 21, 2021
10	Horn Antenna (18GHz-40GHz)	Schwarzbeck	BBHA9170	822	Sep. 22, 2020	Sep. 21, 2021
11	Amplifier (20-3000MHz)	EM Electronics	EM330 Amplifier	N/A	Sep. 22, 2020	Sep. 21, 2021
12	Amplifier (0.5GHz-18GHz)	SCHWARZBECK	8449B	9718-309	Sep. 22, 2020	Sep. 21, 2021
13	Amplifier (18GHz-40GHz)	MITEQ	ZLNA-18-40 G-21	2034381	Sep. 22, 2020	Sep. 21, 2021

For Harmonic & Flicker Test

Item	Kind of Equipment	Manufacturer	Type No.	Serial No.	Last calibration	Calibrated until
1	Harmonic & Flicker	EM TEST	DPA500	0303-04	Sep. 22, 2020	Sep. 21, 2021
2	AC Power Source	EM TEST	ACS500	0203-01	Sep. 22, 2020	Sep. 21, 2021

For Electrostatic Discharge Immunity Test

Item	Kind of Equipment	Manufacturer	Type No.	Serial No.	Last calibration	Calibrated until
1	ESD TEST GENERATOR	HTEC	HESD16	N/A	Sep. 22, 2020	Sep. 21, 2021

For RF Field Strength Susceptibility Test(SMQ)

Item	Kind of Equipment	Manufacturer	Type No.	Serial No.	Last calibration	Calibrated until
1	Signal Generator	R&S	SMT 06	832080/007	Sep. 22, 2020	Sep. 21, 2021
2	Log-Bicon Antenna	Schwarzbeck	VULB9161	4022	Sep. 22, 2020	Sep. 21, 2021
3	Power Amplifier	AR	150W1000M 1	320946	Sep. 22, 2020	Sep. 21, 2021
4	Microwave Horn Antenna	AR	AT4002A	321467	Sep. 22, 2020	Sep. 21, 2021
5	Power Amplifier	AR	25S1G4A	308598	Sep. 22, 2020	Sep. 21, 2021

For Electrical Fast Transient /Burst Immunity Test /For Surge Test /For Voltage Dips Interruptions Test

Item	Kind of Equipment	Manufacturer	Type No.	Serial No.	Last calibration	Calibrated until
1	Surge Generator	HTEC	HCOMPACT 5	N/A	Sep. 22, 2020	Sep. 21, 2021
2	DIPS Generator	HTEC	HV1P16T	N/A	Sep. 22, 2020	Sep. 21, 2021
3	EFT/B Generator	HTEC	HCOMPACT 5	N/A	Sep. 22, 2020	Sep. 21, 2021
4	EFT/B Clamp	HTEC	H3C	N/A	Sep. 22, 2020	Sep. 21, 2021

For Injected Currents Susceptibility Test

Item	Kind of Equipment	Manufacturer	Type No.	Serial No.	Last calibration	Calibrated until
1	Signal Generator	IFR	2023A	202301/368	Sep. 22, 2020	Sep. 21, 2021
2	Power Amplifier	AR	75A250AM1	0320709	Sep. 22, 2020	Sep. 21, 2021
3	CDN	FCC	FCC-801-M2	06043	Sep. 22, 2020	Sep. 21, 2021
4	EM Clamp	FCC	F-203I-23MM	504	Sep. 22, 2020	Sep. 21, 2021

5. EMC EMISSION TEST

5.1. CONDUCTED EMISSION MEASUREMENT

5.1.1. POWER LINE CONDUCTED EMISSION (Frequency Range 150KHz-30MHz)

FREQUENCY (MHz)	Class A (dBuV)		Class B (dBuV)	
	Quasi-peak	Average	Quasi-peak	Average
0.15 -0.5	79.00	66.00	66 - 56 *	56 - 46 *
0.50 -5.0	73.00	60.00	56.00	46.00
5.0 -30.0	73.00	60.00	60.00	50.00

Note:

- (1) The tighter limit applies at the band edges.
- (2) The limit of " * " marked band means the limitation decreases linearly with the logarithm of the frequency in the range.

The following table is the setting of the receiver

Receiver Parameters	Setting
Attenuation	10 dB
Start Frequency	0.15 MHz
Stop Frequency	30 MHz
IF Bandwidth	9 kHz

5.1.2. TEST PROCEDURE

- a. The EUT was placed 0.4 meters from the horizontal ground plane with EUT being connected to the power mains through a line impedance stabilization network (LISN). All other support equipments powered from additional LISN(s). The LISN provide 50 Ohm/ 50uH of coupling impedance for the measuring instrument.
- b. Interconnecting cables that hang closer than 40 cm to the ground plane shall be folded back and forth in the center forming a bundle 30 to 40 cm long.
- c. I/O cables that are not connected to a peripheral shall be bundled in the center. The end of the cable may be terminated, if required, using the correct terminating impedance. The overall length shall not exceed 1 m.
- d. LISN at least 80 cm from nearest part of EUT chassis.
- e. For the actual test configuration, please refer to the related Item –EUT Test Photos.

5.1.3. TEST SETUP

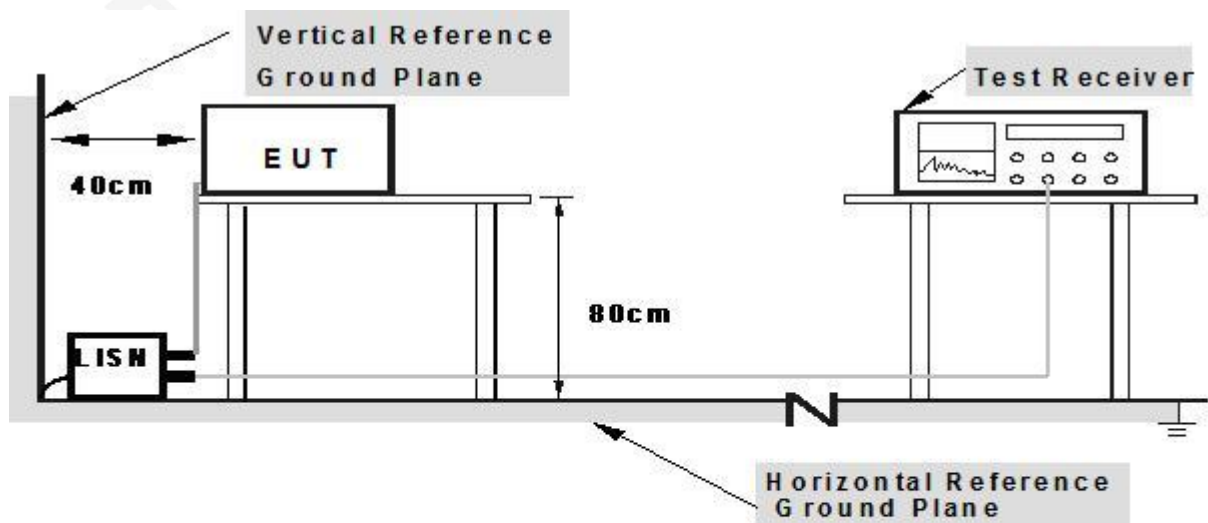

- Note: 1. Support units were connected to second LISN.**
2. Both of LISNs (AMN) are 80 cm from EUT and at least 80 from other units and other metal planes

5.1.4. EUT OPERATING CONDITIONS

The EUT tested system was configured as the statements of 2.2 Unless otherwise a special operating condition is specified in the follows during the testing.

5.1.5. TEST RESULTS

The EUT is powered by the DC only, the test item is not applicable.

5.2. RADIATED EMISSION MEASUREMENT

5.2.1. LIMITS OF RADIATED EMISSION MEASUREMENT (Below 1000MHz)

FREQUENCY (MHz)	Class A (at 10m)	Class B (at 10m)
	dBuV/m	dBuV/m
30 – 230	40	30
230 – 1000	47	37

5.2.2. LIMITS OF RADIATED EMISSION MEASUREMENT (Above 1000MHz)

FREQUENCY (MHz)	Class A (at 10m) dBuV/m		Class B (at 10m) dBuV/m	
	Peak	Avg	Peak	Avg
1000-3000	76	56	70	50
3000-6000	80	60	74	54

Notes:

- (1) The limit for radiated test was performed according to as following:
CISPR 22/ FCC PART 15B /ICES-003.
- (2) The tighter limit applies at the band edges.
- (3) Emission level (dBuV/m)=20log Emission level (uV/m).

5.2.3. TEST PROCEDURE

- a. The measuring distance of at 10 m shall be used for measurements at frequency up to 1GHz. For frequencies above 1GHz, any suitable measuring distance may be used.
- b. The EUT was placed on the top of a rotating table 0.8 meters above the ground at a 10 meter open area test site. The table was rotated 360 degrees to determine the position of the highest radiation.
- c. The height of the equipment or of the substitution antenna shall be 0.8 m; the height of the test antenna shall vary between 1 m to 4 m. Both horizontal and vertical polarizations of the antenna are set to make the measurement.
- d. The initial step in collecting conducted emission data is a spectrum analyzer peak detector mode pre-scanning the measurement frequency range. Significant peaks are then marked and then Quasi Peak detector mode re-measured.
- e. If the Peak Mode measured value compliance with and lower than Quasi Peak Mode Limit, the EUT shall be deemed to meet QP Limits and then no additional QP Mode measurement performed.
- f. For the actual test configuration, please refer to the related Item –EUT Test Photos.

5.2.4. TEST SETUP

(A) Radiated Emission Test Set-Up, Frequency Below 1000MHz

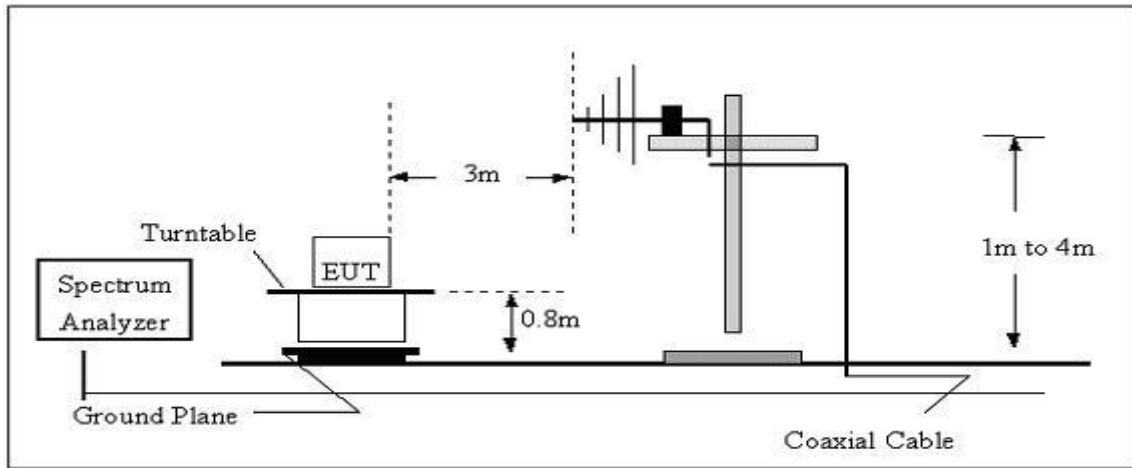

(B) Radiated Emission Test Set-UP Frequency Over 1GHz

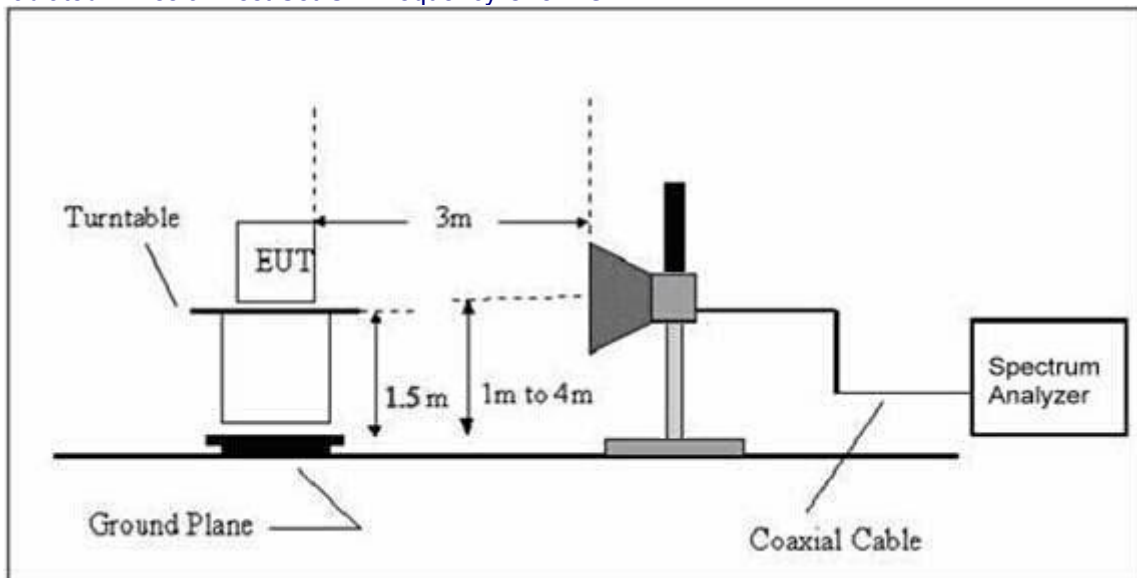

5.2.5. EUT OPERATING CONDITIONS

The EUT tested system was configured as the statements of 2.2 Unless otherwise a special operating condition is specified in the follows during the testing.

5.2.6. TEST RESULTS (30-1000MHz)

EUT :	manifold gauge	Model Name. :	EMG-40V
Temperature :	25.3℃	Relative Humidity :	51%
Pressure :	1010 hPa	Polarization :	Horizontal
Test Voltage :	DC 3.7V	Test Mode :	Communication Mode

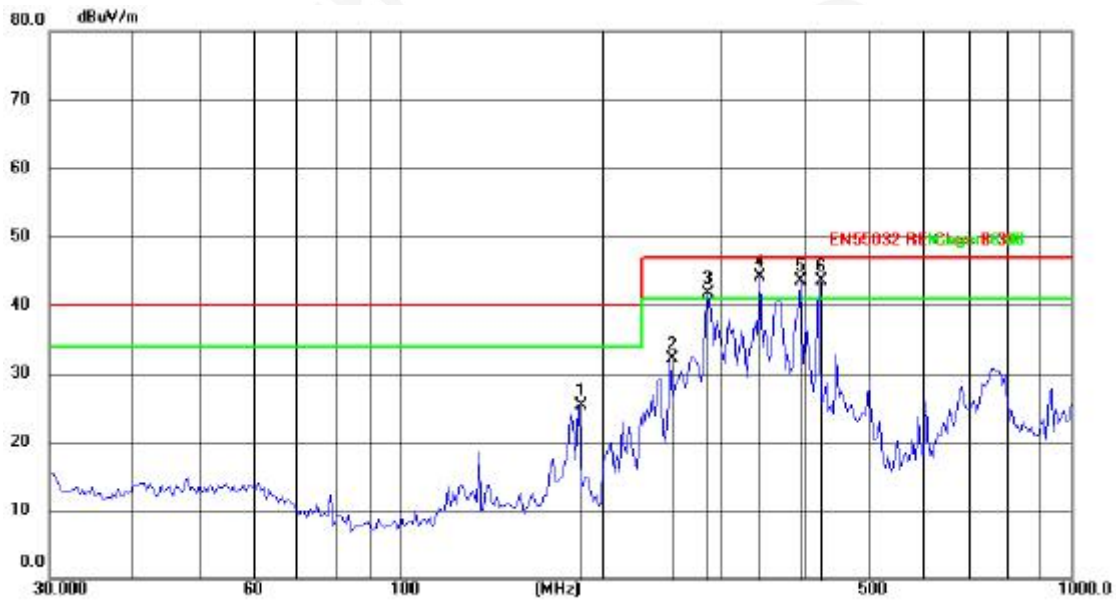

No.	Frequency (MHz)	Reading (dBuV)	Factor (dB/m)	Level (dBuV/m)	Limit (dBuV/m)	Margin (dB)	Detector	Height (cm)	Azimuth (deg.)	P/F	Remark
1	184.1667	44.09	-18.88	25.21	40.00	-14.79	peak				
2	252.5051	49.40	-17.35	32.05	47.00	-14.95	peak				
3	287.9904	58.92	-17.28	41.64	47.00	-5.36	peak				
4	343.1800	62.86	-18.81	44.05	47.00	-2.95	peak				
5	394.8545	62.16	-18.59	43.57	47.00	-3.43	peak				
6	419.8436	61.05	-17.60	43.45	47.00	-3.55	peak				

EUT :	manifold gauge	Model Name. :	EMG-40V
Temperature :	25.3°C	Relative Humidity :	51%
Pressure :	1010 hPa	Polarization :	Vertical
Test Voltage :	DC 3.7V	Test Mode :	Communication Mode

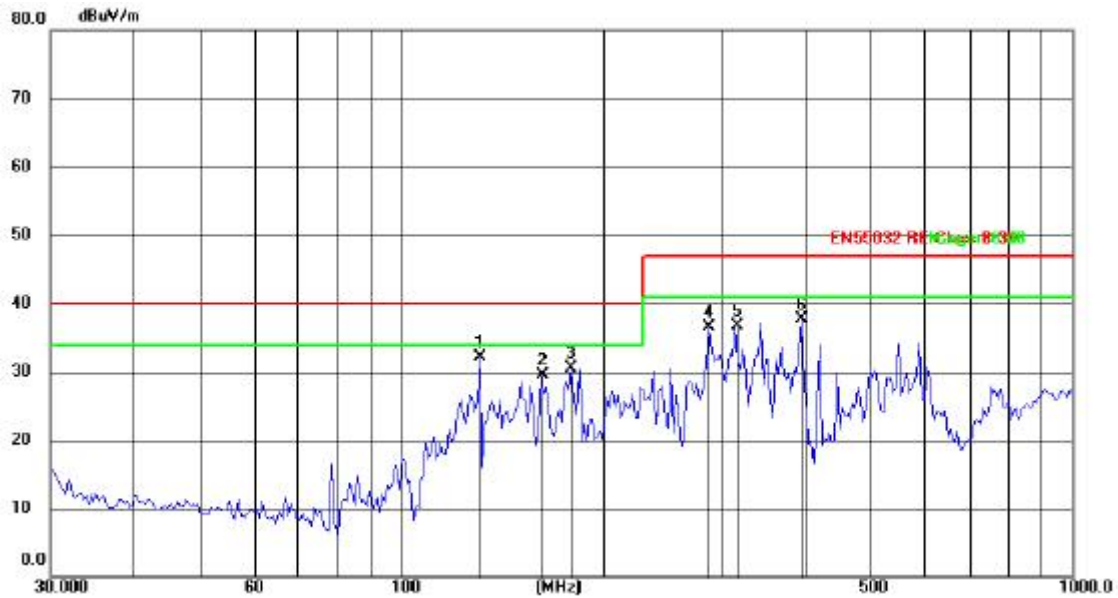

No.	Frequency (MHz)	Reading (dBuV)	Factor (dB/m)	Level (dBuV/m)	Limit (dBuV/m)	Margin (dB)	Detector	Height (cm)	Azimuth (deg.)	P/F	Remark
1	130.8369	53.59	-21.44	32.15	40.00	-7.85	peak				
2	161.4742	50.32	-20.78	29.54	40.00	-10.46	peak				
3	179.3863	51.22	-20.64	30.58	40.00	-9.42	peak				
4	287.9904	57.11	-20.58	36.53	47.00	-10.47	peak				
5	314.3765	56.48	-19.86	36.62	47.00	-10.38	peak				
6	394.8545	54.90	-17.20	37.70	47.00	-9.30	peak				

5.3. LIMITS OF HARMONICS CURRENT

IEC 555-2					
Table - I			Table - II		
Equipment Category	Harmonic Order n	Max. Permissible Harmonic Current (in Amperes)	Equipment Category	Harmonic Order n	Max. Permissible Harmonic Current (in Amperes)
Non Portable Tools or TV Receivers	Odd Harmonics		TV Receivers	Odd Harmonics	
	3	2.30		3	0.80
	5	1.14		5	0.60
	7	0.77		7	0.45
	9	0.40		9	0.30
	11	0.33		11	0.17
	13	0.21		13	0.12
	15 ≤ n ≤ 39	0.15 · 15/n		15 ≤ n ≤ 39	0.10 · 15/n
	Even Harmonics			Even Harmonics	
	2	1.08		2	0.30
4	0.43	4	0.15		
8	0.30				
8 ≤ n ≤ 40	0.23 · 8/n	DC	0.05		

EN 61000-3-2/IEC 61000-3-2					
Equipment Category	Max. Permissible Harmonic Current (in Amperes)	Equipment Category	Harmonic Order n	Max. Permissible Harmonic Current (in A)	Max. Permissible Harmonic Current (mA/w)
Class A	Same as Limits Specified in 4-2.1, Table - I, but only odd harmonics required	Class D	3	2.30	3.4
			5	1.14	1.9
			7	0.77	1.0
			9	0.40	0.5
			11	0.33	0.35
			13 ≤ n ≤ 39	see Table I	3.85/n
only odd harmonics required					

5.3.1. TEST PROCEDURE

- a. The EUT was placed on the top of a wooden table 0.8 meters above the ground and operated to produce the maximum harmonic components under normal operating conditions.
- b. The classification of EUT is according to section 5 of EN 61000-3-2: 2000. The EUT is classified as follows:
Class A: Balanced three-phase equipment, Household appliances excluding equipment as Class D, Tools excluding portable tools, Dimmers for incandescent lamps, audio equipment, equipment not specified in one of the three other classes.
Class B: Portable tools. Portable tools.; Arc welding equipment which is not professional equipment.
Class C: Lighting equipment.
Class D: Equipment having a specified power less than or equal to 600 W of the following types: Personal computers and personal computer monitors and television receivers.
- c. The correspondent test program of test instrument to measure the current harmonics emanated from EUT is chosen. The measure time shall be not less than the time necessary for the EUT to be exercised.
- d. For the actual test configuration, please refer to the related item –EUT Test Photos.

5.3.2. EUT OPERATING CONDITIONS

The EUT tested system was configured as the statements of 2.2 Unless otherwise a special operating condition is specified in the follows during the testing.

5.3.3. TEST SETUP

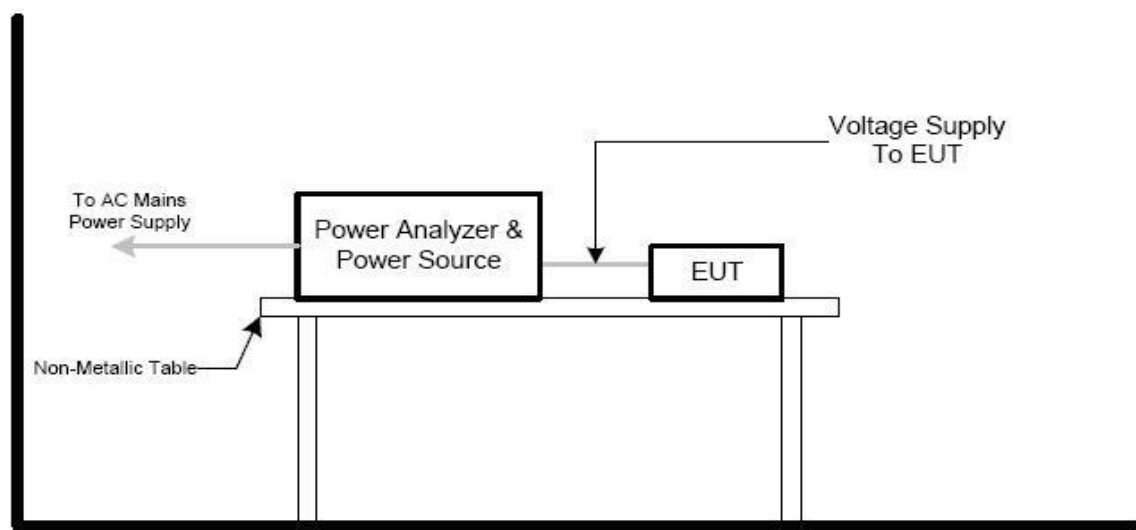

5.3.4. TEST RESULTS

The EUT is powered by the DC only, the test item is not applicable.

5.4. VOLTAGE FLUCTUATION AND FLICKERS

5.4.1. LIMITS OF VOLTAGE FLUCTUATION AND FLICKERS

Tests	Limits		Descriptions
	IEC555-3	IEC/EN 61000-3-3	
Pst	≤ 1.0, Tp= 10 min.	≤ 1.0, Tp= 10 min.	Short Term Flicker Indicator
Plt	N/A	≤ 0.65, Tp=2 hr.	Long Term Flicker Indicator
dc	≤ 3%	≤ 3.3%	Relative Steady-State V-Chang
dmax	≤ 4%	≤ 4%	Maximum Relative V-change
d (t)	N/A	≤ 3.3% for > 500 ms	Relative V-change characteristic

5.4.2 TEST PROCEDURE

a. Harmonic Current Test:

Test was performed according to the procedures specified in Clause 5.0 of IEC555-2 and/or Sub-clause 6.2 of IEC/EN 61000-3-2 depend on which standard adopted for compliance measurement.

b. Fluctuation and Flickers Test:

Tests was performed according to the Test Conditions/Assessment of Voltage Fluctuations specified in Clause 5.0/6.0 of IEC555-3 and/or Clause 6.0/4.0 of IEC/EN 61000-3-3 depend on which standard adopted for compliance measurement.

c. All types of harmonic current and/or voltage fluctuation in this report are assessed by direct measurement using flicker-meter.

d. For the actual test configuration, please refer to the related Item –EUT Test Photos.

5.4.3 EUT OPERATING CONDITIONS

The EUT tested system was configured as the statements of 2.2 Unless otherwise a special operating condition is specified in the follows during the testing.

5.4.4 TEST SETUP

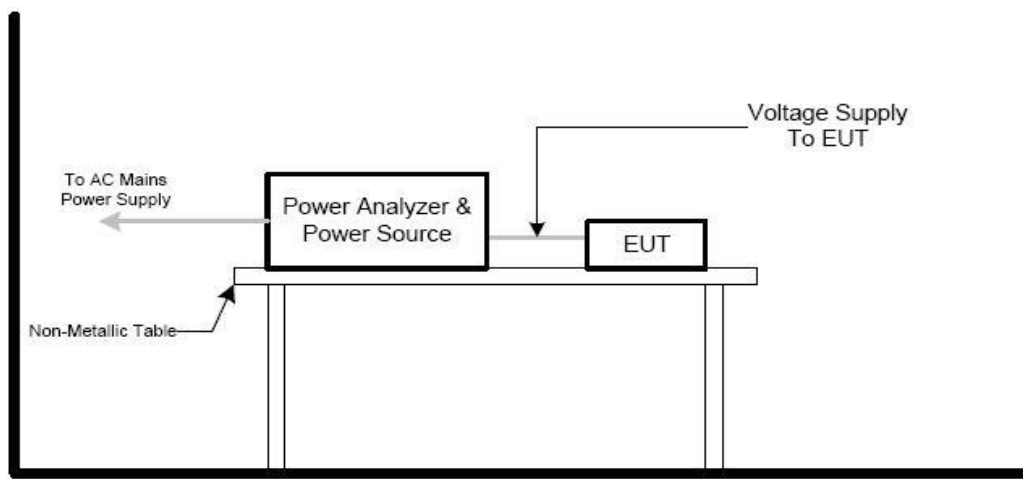

5.4.5 TEST RESULTS

The EUT is powered by the DC only, the test item is not applicable.

6. EMC IMMUNITY TEST

6.1. GENERAL PERFORMANCE CRITERIA

PERFORMANCE CRITERIA

According To **EN 301489-17** standard, The General Performance Criteria As Following:

Criteria	During the test	After the test
A	Shall operate as intended May show degradation of performance (see note 1) Shall be no loss of function Shall be no unintentional transmissions	Shall operate as intended Shall be no degradation of performance (see note 2) Shall be no loss of function Shall be no loss of stored data or user programmable functions
B	May show loss of function (one or more) May show degradation of performance (see note 1) No unintentional transmissions	Functions shall be self-recoverable Shall operate as intended after recovering Shall be no degradation of performance (see note 2) Shall be no loss of stored data or user programmable functions
C	May be loss of function (one or more)	Functions shall be recoverable by the operator Shall operate as intended after recovering Shall be no degradation of performance (see note 2)

NOTE 1: Degradation of performance during the test is understood as a degradation to a level not below a minimum performance level specified by the manufacturer for the use of the apparatus as intended. In some cases the specified minimum performance level may be replaced by a permissible degradation of performance. If the minimum performance level or the permissible performance degradation is not specified by the manufacturer then either of these may be derived from the product description and documentation (including leaflets and advertising) and what the user may reasonably expect from the apparatus if used as intended.

NOTE 2: no degradation of performance after the test is understood as any degradation below a minimum performance level specified by the manufacturer for the use of the apparatus as intended. In some cases the specified minimum performance level may be replaced by a permissible degradation of performance. After the test no change of actual operating data or user retrievable data is allowed. If the minimum performance level or the permissible performance degradation is not specified by the manufacturer then either of these may be derived from the product description and documentation (including leaflets and advertising) and what the user may reasonably expect from the apparatus if used as intended.

PERFORMANCE FOR TT

The performance criteria B shall apply, except for voltage dips of 100 ms and voltage interruptions of 5 000 ms duration, for which performance criteria C shall apply. Tests shall be repeated with the EUT in standby mode (if applicable) to ensure that unintentional transmission does not occur. In systems using acknowledgement signals, it is recognized that an acknowledgement (ACK) or not-acknowledgement (NACK) transmission may occur, and steps should be taken to ensure that any transmission resulting from the application of the test is correctly interpreted.

PERFORMANCE FOR TR

The performance criteria B shall apply, except for voltage dips of 100 ms and voltage interruptions of 5 000 ms duration for which performance criteria C shall apply. Where the EUT is a transceiver, under no circumstances, shall the transmitter operate unintentionally during the test. In systems using acknowledgement signals, it is recognized that an ACK or NACK transmission may occur, and steps should be taken to ensure that any transmission resulting from the application of the test is correctly interpreted.

PERFORMANCE FOR CT

The performance criteria A shall apply. Tests shall be repeated with the EUT in standby mode (if applicable) to ensure that unintentional transmission does not occur. In systems using acknowledgement signals, it is recognized that an Acknowledgement (ACK) or Not Acknowledgement (NACK) transmission may occur, and steps should be taken to ensure that any transmission resulting from the application of the test is correctly interpreted.

PERFORMANCE FOR CR

The performance criteria A shall apply. Where the EUT is a transceiver, under no circumstances, shall the transmitter operate unintentionally during the test. In systems using acknowledgement signals, it is recognized that an ACK or NACK transmission may occur, and steps should be taken to ensure that any transmission resulting from the application of the test is correctly interpreted.

6.2. GENERAL PERFORMANCE CRITERIA TEST SETUP

The EUT tested system was configured as the statements of **2.2** Unless otherwise a special operating condition is specified in the follows during the testing.

7. ESD TESTING

7.1 TEST SPECIFICATION

Basic Standard:	IEC/EN 61000-4-2
Discharge Impedance:	330 ohm / 150 pF
Required Performance	B
Discharge Voltage:	Air Discharge : 2kV/4kV/8kV (Direct) Contact Discharge : 2kV/4kV (Direct/Indirect)
Polarity:	Positive & Negative
Number of Discharge:	Air Discharge: min. 20 times at each test point Contact Discharge: min. 200 times in total
Discharge Mode:	AC Discharge
Discharge Period:	1 second minimum

7.2 TEST PROCEDURE

The test generator necessary to perform direct and indirect application of discharges to the EUT in the following manner:

- a. Contact discharge was applied to conductive surfaces and coupling planes of the EUT. During the test, it was performed with single discharges. For the single discharge time between successive single discharges was at least 1 second. The EUT shall be exposed to at least 200 discharges, 100 each at negative and positive polarity, at a minimum of four test points. One of the test points shall be subjected to at least 50 indirect discharges to the center of the front edge of the horizontal coupling plane. The remaining three test points shall each receive at least 50 direct contact discharges.
If no direct contact test points are available, then at least 200 indirect discharges shall be applied in the indirect mode. Test shall be performed at a maximum repetition rate of one discharge per second.
Vertical Coupling Plane (VCP):
The coupling plane, of dimensions 0.5m x 0.5m, is placed parallel to, and positioned at a distance 0.1m from, the EUT, with the Discharge Electrode touching the coupling plane.
The four faces of the EUT will be performed with electrostatic discharge.
Horizontal Coupling Plane (HCP):
The coupling plane is placed under to the EUT. The generator shall be positioned vertically at a distance of 0.1m from the EUT, with the Discharge Electrode touching the coupling plane.
The four faces of the EUT will be performed with electrostatic discharge.
- b. Air discharges at insulation surfaces of the EUT.
It was at least ten single discharges with positive and negative at the same selected point.
- c. For the actual test configuration, please refer to the related Item –EUT Test Photos.

7.3 TEST SETUP

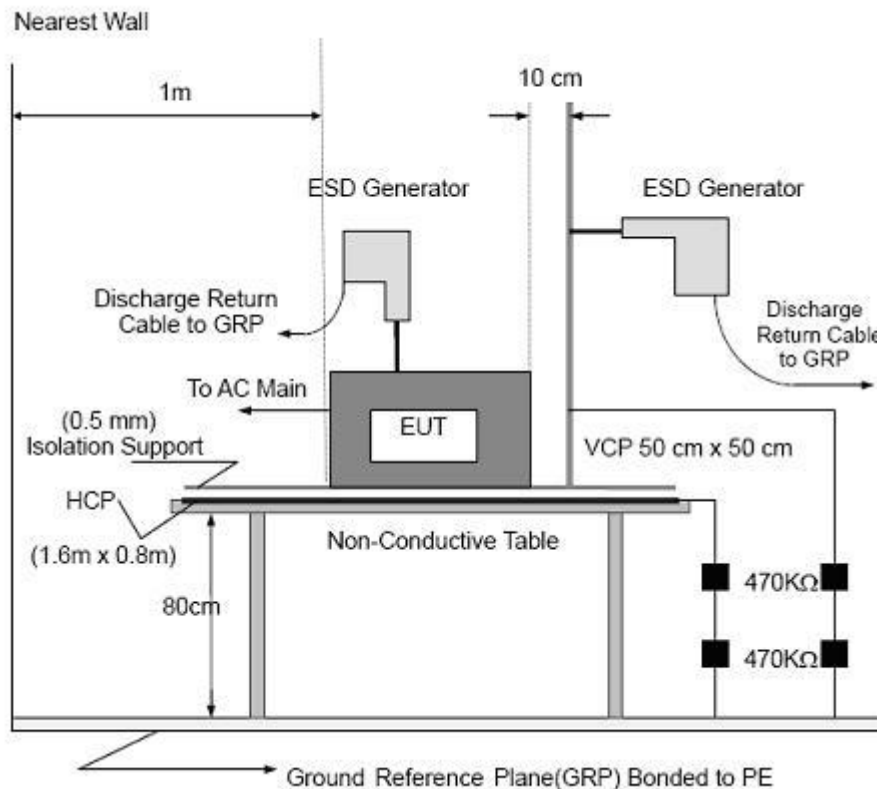

Note:

TABLE-TOP EQUIPMENT

The configuration consisted of a wooden table 0.8 meters high standing on the Ground Reference Plane. The GRP consisted of a sheet of aluminum at least 0.25mm thick, and 2.5 meters square connected to the protective grounding system. A Horizontal Coupling Plane (1.6m x 0.8m) was placed on the table and attached to the GRP by means of a cable with 940k total impedance. The equipment under test, was installed in a representative system as described in section 7 of IEC /EN 61000-4-2, and its cables were placed on the HCP and isolated by an insulating support of 0.5mm thickness. A distance of 1-meter minimum was provided between the EUT and the walls of the laboratory and any other metallic structure.

FLOOR-STANDING EQUIPMENT

The equipment under test was installed in a representative system as described in section 7 of IEC/EN 61000-4-2, and its cables were isolated from the Ground Reference Plane by an insulating support of 0.1-meter thickness. The GRP consisted of a sheet of aluminum that is at least 0.25mm thick, and 2.5meters square connected to the protective grounding system and extended at least 0.5 meters from the EUT on all sides.

7.4 TEST RESULTS

EUT :	manifold gauge	Model Name. :	EMG-40V
Temperature :	25.1℃	Relative Humidity :	55%
Pressure :	1010 hPa	Test Power :	DC 3.7V
Test Mode	Communication Mode		

Mode	Air Discharge								Contact Discharge								Observation	Criterion	Result
	2		4		8		10		2		4		6		8				
Test Location	+	-	+	-	+	-	+	-	+	-	+	-	+	-	+	-			
HCP																	TT,TR	B	PASS
VCP									A	A	A	A							PASS
USB port									A	A	A	A							PASS
enclosure	A	A	A	A	A	A													PASS
slot	A	A	A	A	A	A													PASS
Button	A	A	A	A	A	A													PASS

Note:

- 1) P/N denotes the Positive/Negative polarity of the output voltage.
- 2) Test condition:
 Direct / Indirect (HCP/VCP) discharges: Minimum 50 times (Positive/Negative) at each point. Air discharges: Minimum 10 times (Positive/Negative) at each point.
- 3) N/A - denotes test is not applicable in this test report
- 4) There was not any unintentional transmission in standby mode

8. RS TESTING

8.1 TEST SPECIFICATION

Basic Standard:	IEC/EN 61000-4-3
Required Performance	A
Frequency Range:	80 MHz - 6000 MHz
Field Strength:	3 V/m
Modulation:	1kHz Sine Wave, 80%, AM Modulation
Frequency Step:	1 % of fundamental
Polarity of Antenna:	Horizontal and Vertical
Test Distance:	3 m
Antenna Height:	0.8 m
Dwell Time:	at least 3 seconds

8.2 TEST PROCEDURE

The EUT and support equipment, which are placed on a table that is 0.8 meter above ground and the testing was performed in a fully-anechoic chamber.

The testing distance from antenna to the EUT was 3 meters.

The other condition as following manner:

- a. The field strength level was 3V/m.
- b. The frequency range is swept from 80 MHz to 6000 MHz, & 1400MHz - 2700MHz with the signal 80%amplitude modulated with a 1kHz sine wave. The rate of sweep did not exceed 1.5×10^{-3} decade/s. Where the frequency range is swept incrementally, the step size was 1% of fundamental.
- c. Sweep Frequency 900 MHz, with the Duty Cycle:1/8 and Modulation: Pulse 217 Hz(if applicable)
- d. The dwell time at each frequency shall be not less than the time necessary for the EUT to be able to respond.
- e. The test was performed with the EUT exposed to both vertically and horizontally polarized fields on each of the four sides.
- f. For the actual test configuration, please refer to the related Item –EUT Test Photos.

8.3 TEST SETUP

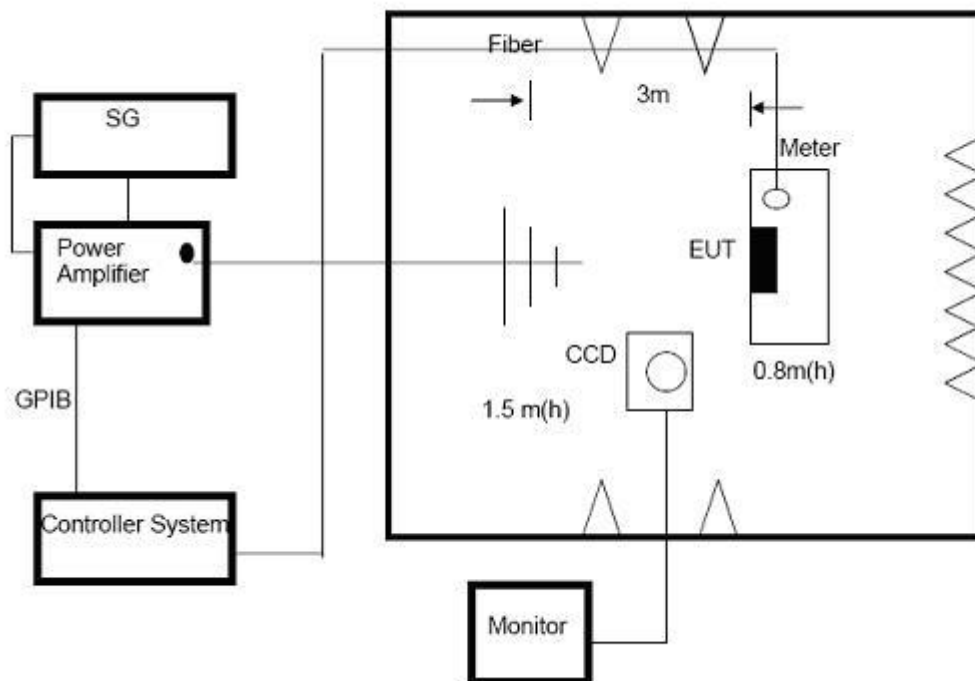

Note:

TABLE-TOP EQUIPMENT

The EUT installed in a representative system as described in section 7 of IEC/EN 61000-4-3 was placed on a non-conductive table 0.8 meters in height. The system under test was connected to the power and signal wire according to relevant installation instructions.

FLOOR-STANDING EQUIPMENT

The EUT installed in a representative system as described in section 7 of IEC/EN 61000-4-3 was placed on a non-conductive wood support 0.1 meters in height. The system under test was connected to the power and signal wire according to relevant installation instructions.

8.4 TEST RESULTS

EUT :	manifold gauge	Model Name. :	EMG-40V
Temperature :	24.8°C	Relative Humidity :	54%
Pressure :	1010 hPa	Test Power :	DC 3.7V
Test Mode	Communication Mode		

Frequency Range (MHz)	RF Field Position	R.F. Field Strength	Azimuth	Observation	Perform. Criteria	Results	Judgment
80~6000	H / V	3 V/m (rms) AM Modulated 1000Hz, 80%	Front	CT,CR	A	A	PASS
			Rear				
			Left				
			Right				

Note:

- 1) P/N denotes the Positive/Negative polarity of the output voltage.
- 2) N/A - denotes test is not applicable in this test report.
- 3) There was no change operated with initial operating during the test.
- 4) There was not any unintentional transmission in standby mode

9. EFT/BURST TESTING

9.1 TEST SPECIFICATION

Basic Standard:	IEC/EN 61000-4-4
Required Performance	B
Test Voltage:	Power Line : 1 kV Signal/Control Line : 0.5 KV
Polarity:	Positive & Negative
Impulse Frequency:	5 kHz
Impulse Wave shape :	5/50 ns
Burst Duration:	15 ms
Burst Period:	300 ms
Test Duration:	Not less than 1 min.

9.2 TEST PROCEDURE

The EUT and support equipment, are placed on a table that is 0.8 meter above a metal ground plane measured 1m*1m min. and 0.65mm thick min.

The other condition as following manner:

- a. The length of power cord between the coupling device and the EUT should not exceed 1 meter.
- b. Both positive and negative polarity discharges were applied.
- c. The duration time of each test sequential was 1 minute
- d. For the actual test configuration, please refer to the related Item –EUT Test Photos.

9.3 TEST SETUP

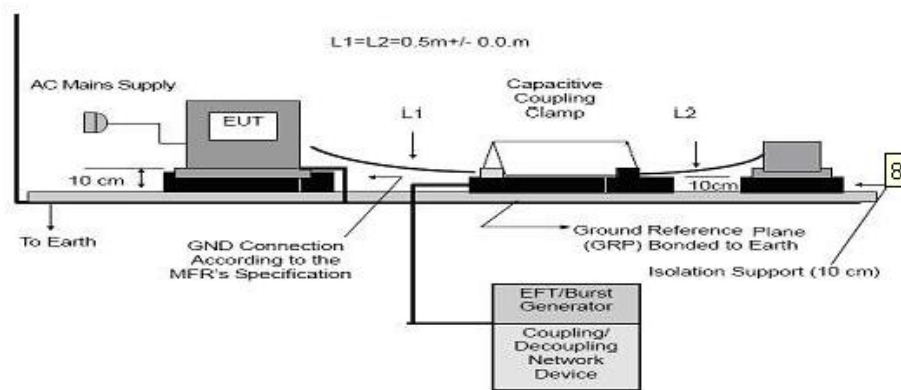
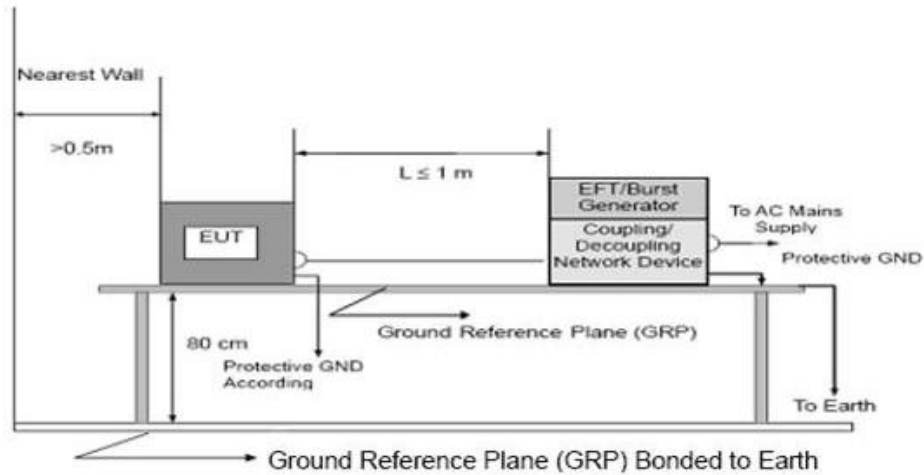

Note:

TABLE-TOP EQUIPMENT

The configuration consisted of a wooden table (0.8m high) standing on the Ground Reference Plane. The GRP consisted of a sheet of aluminum (at least 0.25mm thick and 2.5m square) connected to the protective grounding system. A minimum distance of 0.5m was provided between the EUT and the walls of the laboratory or any other metallic structure.

FLOOR-STANDING EQUIPMENT

The EUT installed in a representative system as described in section 7 of IEC/EN 61000-4-4 and its cables, were isolated from the Ground Reference Plane by an insulating support that is 0.1-meter thick. The GRP consisted of a sheet of aluminum (at least 0.25mm thick and 2.5m square) connected to the protective grounding system.

9.4 TEST RESULTS

The EUT is powered by the DC only, the test item is not applicable.

10. SURGE TESTING

10.1 TEST SPECIFICATION

Basic Standard:	IEC/EN 61000-4-5
Required Performance	B
Wave-Shape:	Combination Wave 1.2/50 us Open Circuit Voltage 8 /20 us Short Circuit Current
Test Voltage:	Power Line : 0.5 kV, 1 kV, 2 kV
Surge Input/Output:	L1-A1, A2, A3, A4, A5, A6, A7, L1-PE, A1, A2, A3, A4, A5, A6, A7-PE
Generator Source:	2 ohm between networks
Impedance:	12 ohm between network and ground
Polarity:	Positive/Negative
Phase Angle:	0 /90/180/270
Pulse Repetition Rate:	1 time / min. (maximum)
Number of Tests:	5 positive and 5 negative at selected points

10.2 TEST PROCEDURE

a. For EUT power supply:

The surge is to be applied to the EUT power supply terminals via the capacitive coupling network. Decoupling networks are required in order to avoid possible adverse effects on equipment not under test that may be powered by the same lines, and to provide sufficient decoupling impedance to the surge wave. The power cord between the EUT and the coupling/decoupling networks shall be 2meters in length (or shorter).

b. For test applied to unshielded unsymmetrically operated interconnection lines of EUT:

The surge is applied to the lines via the capacitive coupling. The coupling /decoupling networks shall not influence the specified functional conditions of the EUT. The interconnection line between the EUT and the coupling/decoupling networks shall be 2 meters in length (or shorter).

c. For test applied to unshielded symmetrically operated interconnection /telecommunication lines of EUT:

The surge is applied to the lines via gas arrestors coupling. Test levels below the ignition point of the coupling arrestor cannot be specified. The interconnection line between the EUT and the coupling/decoupling networks shall be 2 meters in length (or shorter).

d. For the actual test configuration, please refer to the related Item –EUT Test Photos.

10.3 TEST SETUP

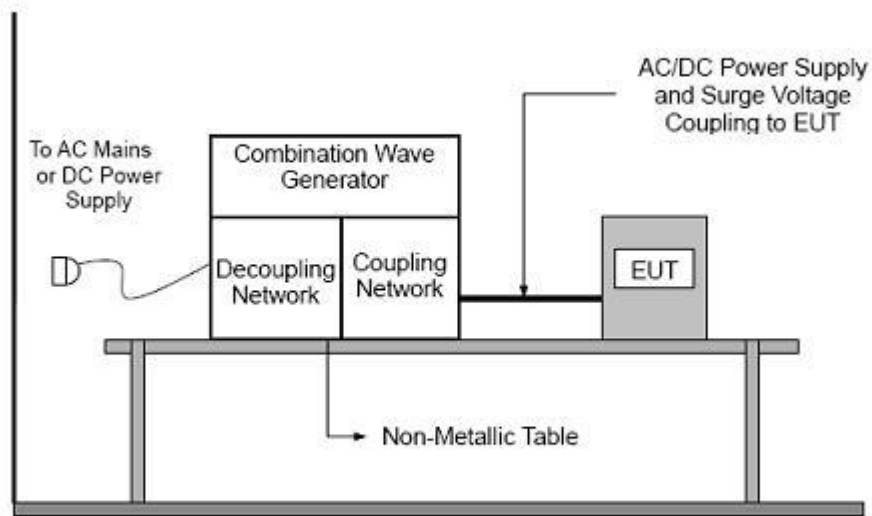

10.4 TEST RESULTS

The EUT is powered by the DC only, the test item is not applicable.

11. INJECTION CURRENT TESTING

11.1 TEST SPECIFICATION

Basic Standard:	IEC/EN 61000-4-6
Required Performance	A
Frequency Range:	0.15 MHz - 80 MHz
Field Strength:	3 Vr.m.s.
Modulation:	1kHz Sine Wave, 80%, AM Modulation
Frequency Step:	1 % of fundamental
Dwell Time:	at least 3 seconds

11.2 TEST PROCEDURE

The EUT and support equipment, are placed on a table that is 0.8 meter above a metal ground plane measured 1m*1m min. and 0.65mm thick min.

The other condition as following manner:

- a. The field strength level was 3V.
- b. The frequency range is swept from 150 KHz to 80 MHz, with the signal 80%amplitude modulated with a 1kHz sine wave. The rate of sweep did not exceed 1.5×10^{-3} decade/s. Where the frequency range is swept incrementally, the step size was 1% of fundamental.
- c. The dwell time at each frequency shall be not less than the time necessary for the EUT to be able to respond.
- d. For the actual test configuration, please refer to the related Item –EUT Test Photos.

11.3 TEST SETUP

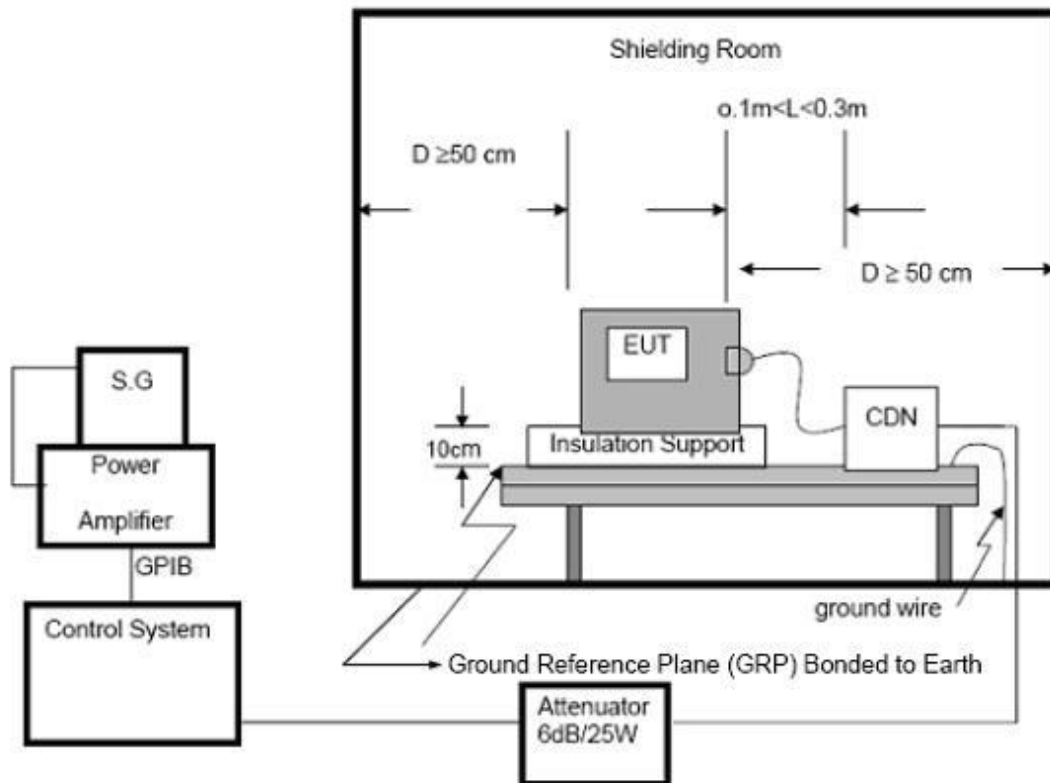

For the actual test configuration, please refer to the related Item –EUT Test Photos.

NOTE:

FLOOR-STANDING EQUIPMENT

The equipment to be tested is placed on an insulating support of 0.1 meters height above a ground reference plane. All relevant cables shall be provided with the appropriate coupling and decoupling devices at a distance between 0.1 meters and 0.3 meters from the projected geometry of the EUT on the ground reference plane.

11.4 TEST RESULTS

The EUT is powered by the DC only, the test item is not applicable.

12. VOLTAGE INTERRUPTION/DIPS TESTING

12.1 TEST SPECIFICATION

Basic Standard:	IEC/EN 61000-4-11
Required Performance	100% reduction, 0.5 Cycle 100% reduction, 1.0 Cycle 30% reduction, 25 Cycles
Voltage Interruptions:	100% reduction, 250 Cycles
Test Duration Time:	Minimum three test events in sequence
Interval between Event:	Minimum ten seconds
Phase Angle:	0°/45°/90°/135°/180°/225°/270°/315°/360°
Test Cycle:	3 times

12.2 TEST PROCEDURE

The EUT shall be tested for each selected combination of test levels and duration with a sequence of three dips/interruptions with intervals of 10 s minimum (between each test event). Each representative mode of operation shall be tested. Abrupt changes in supply voltage shall occur at zero crossings of the voltage waveform.

12.3 TEST SETUP

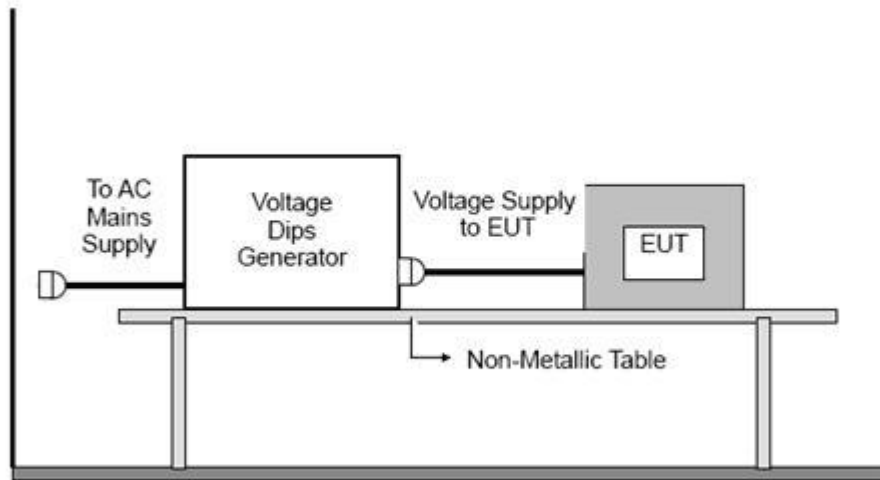

For the actual test configuration, please refer to the related Item –EUT Test Photos.

12.4 TEST RESULTS

The EUT is powered by the DC only, the test item is not applicable.

13. PHOTOS OF EUT

EUT Photo 1



EUT Photo 2

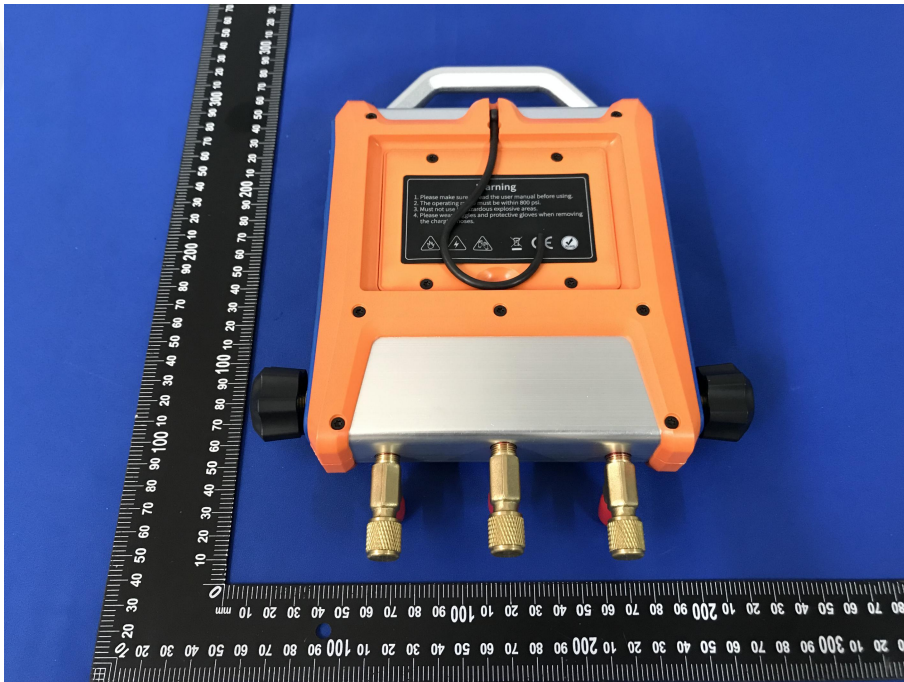

EUT Photo 3

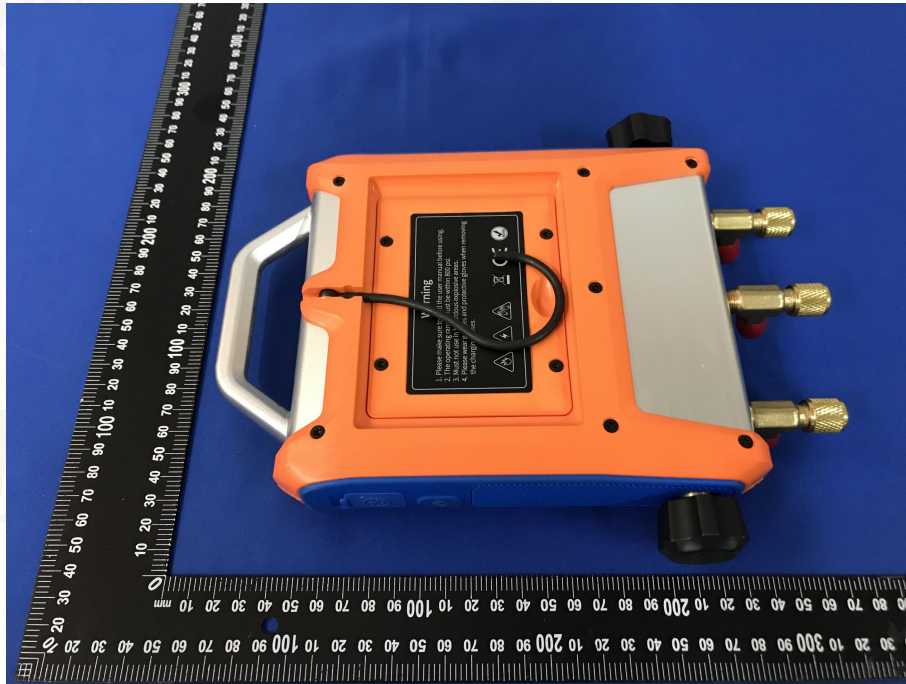

EUT Photo 4

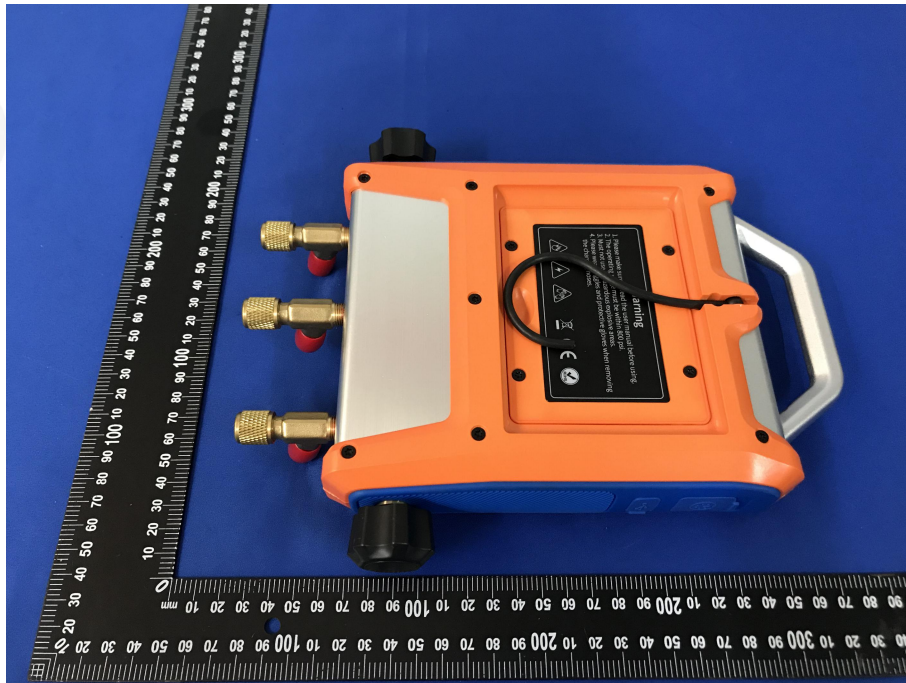

EUT Photo 5



EUT Photo 6

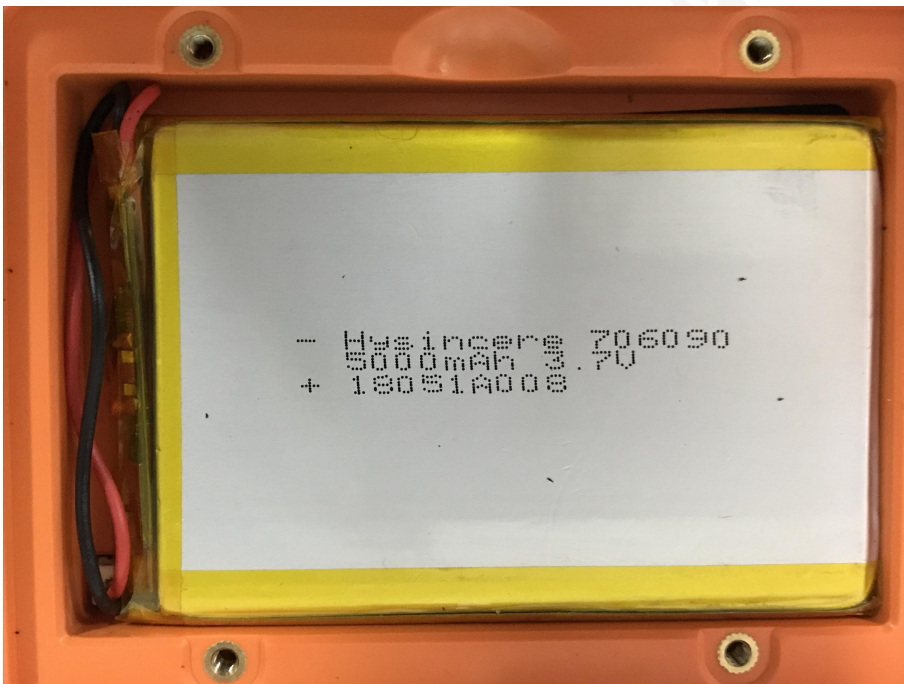

EUT Photo 7



EUT Photo 8

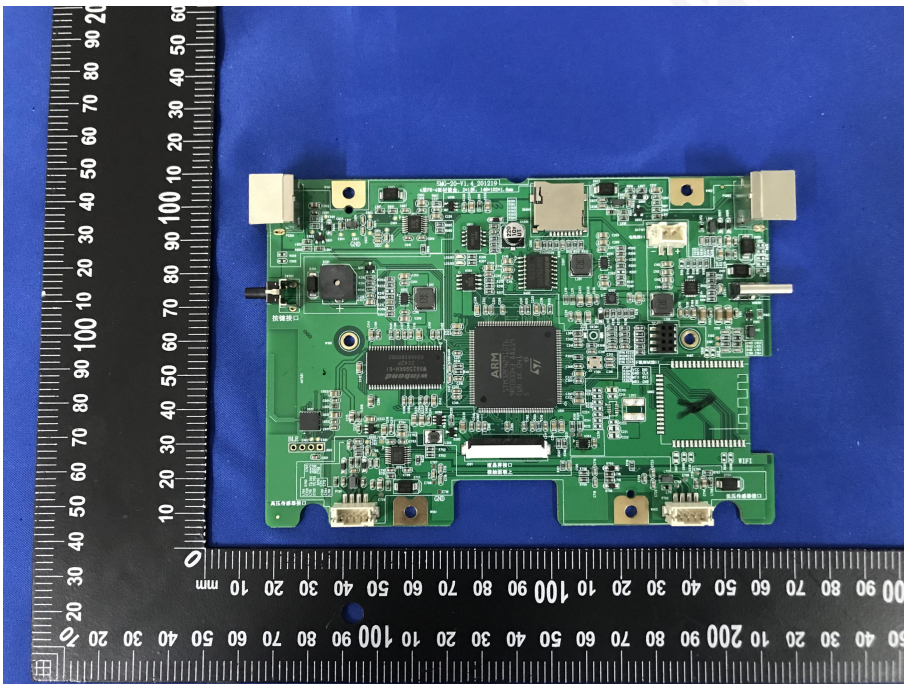

EUT Photo 9

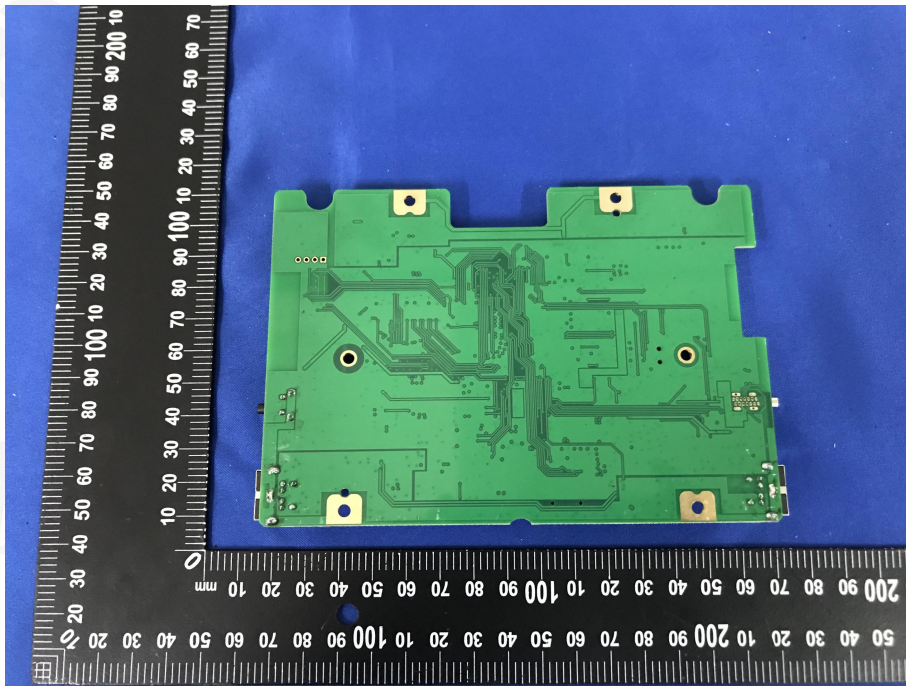

14. PHOTOS OF TEST SETUP

RE



***** END OF REPORT *****