



Wood Trick[®]
A NEW WORLD OF ART

RU Внимание! **UKR** Увага! **ENG** Attention! **DEU** Achtung! **FRA** Attention! **POL** Uwaga! **SPA** Atención! **ITA** Attenzione!



RU Не поджигать! **UKR** Не підпалювати! **ENG** Do not set fire to it! **DEU** Nicht anzünden! **FRA** Ne pas allumer! **POL** nie podpalaj! **SPA** No prender fuego! **ITA** Non dare fuoco!



RU Осторожно! Острые детали! **UKR** Обережно! Гострі деталі! **ENG** Caution! Sharp parts! **DEU** Vorsichtig! Scharfe Details! **FRA** Attention Détails tranchants! **POL** Uwaga! Ostre szczegóły! **SPA** Cuidado! Piezas cortantes! **ITA** Attenzione! Dettagli nitidi!

Wood Trick
A NEW WORLD OF ART

RU Рекомендация: если возникли сложности при скреплении деталей, обработайте зубочистки парафином. **UKR** Рекомендація: якщо виникли складнощі при скріпленні деталей, обробіть зубочистки парафіном. **ENG** Recommendation: if you have difficulty in connecting parts, treat toothpicks with paraffin. **DEU** Empfehlung: Wenn Sie Schwierigkeiten haben, Teile zu verbinden, behandeln Sie Zahnstocher mit Paraffin. **FRA** Recommandation: si vous avez des difficultés pièces de fixation, traitez les cure-dents avec de la paraffine. **POL** Zalecenie: jeśli masz trudności z połączeniem części, obsługiwać wykałaczki parafiną. **SPA** Recomendación: si tiene dificultades para fijar piezas, trate mondadientes con parafina. **ITA** Raccomandazione: in caso di difficoltà nel fissare le parti, trattare gli stuzzicadenti con paraffina.

RU Конструктор не требует применения клея. **UKR** Конструктор не вимагає застосування клею. **ENG** The assembling of constructor does not require to use glue. **DEU** Für die Montage des Konstruktors ist kein Klebstoff erforderlich. **FRA** Aucune colle n'est nécessaire pour monter le constructeur. **POL** Montaż konstruktora odbywa się bez kleju. **SPA** El montaje constructor no requiere el uso de pegamento. **ITA** L'assemblaggio non richiede l'uso di colla.

RU Хрупкие детали! При извлечении элементов конструктора из карты будьте аккуратны! **UKR** Крихкі деталі! Під час вилучення конструктора з карти будьте обережні! **ENG** Fragile details! Be careful when removing the constructor from the card! **DEU** Zerbrechliche Details! Seien Sie vorsichtig, wenn Sie den Konstruktor von der Karte entfernen! **FRA** Détails fragiles! Faites attention en retirant les éléments de la construction de la carte! **POL** Kruche szczegóły! Przedmioty należy wyjmować z karty ostrożnie! **SPA** Detalles frágiles! Sea prudente al sacar elementos de mecano del tarjeta! **ITA** Dettagli fragili! Gli elementi vanno estratti dalla scheda con cautela!

RU Все элементы входящие в зацепление необходимо зачистить наждачной бумагой и смазать парафином. **UKR** Всі елементи, що входять у зачеплення необхідно зачистити наждачним папером і змастити парафіном. **ENG** All elements that interlock must be sanded with sandpaper and greased with paraffin. **DEU** Alle eingreifenden Teile müssen mit Sandpapier gereinigt und mit Paraffin eingefettet werden. **FRA** Il faut nettoyer tous les éléments de l'accrochage à l'aide du papier-meri et les traiter avec de la paraffine. **POL** Wszystkie zaczepione elementy należy oczyścić papierem ściernym i nasmarować parafiną. **SPA** Todos los elementos que se enganchan deben limpiarse con papel de lija y engrasarse con parafina. **ITA** Tutti gli elementi agganciati devono essere puliti con carta vetrata e ingrassati con paraffina.

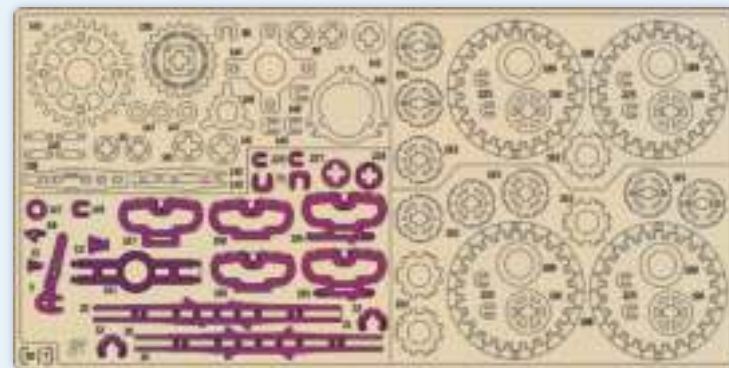

RU Запасные части. **UKR** Запасні деталі. **ENG** Spare parts. **DEU** Ersatzteile. **FRA** Pièces de rechange. **POL** Części zamienne. **SPA** Repuestos. **ITA** Pezzi di ricambio.

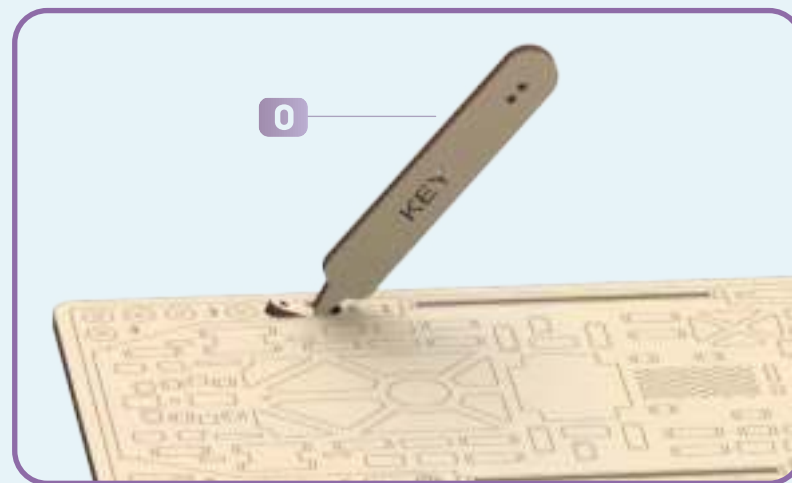

4

RU Вспомогательный инструмент для сборки или измерения расстояний. **UKR** Допоміжний інструмент для збірки або вимірювання відстаней. **ENG** Auxiliary tool for assembling or measuring distances. **DEU** Hilfswerkzeug zum Montieren oder Messen von Abständen. **FRA** Outil auxiliaire pour assembler ou mesurer des distances. **POL** Narzędzie pomocnicze do montażu lub pomiaru odległości. **SPA** Herramienta auxiliar para ensamblar o medir distancias. **ITA** Strumento ausiliario per l'assemblaggio o la misurazione delle distanze.

RU Условные обозначения. **UKR** Умовні позначення. **ENG** Symbolic notations. **DEU** Erläuterungen. **FRA** Légende. **POL** Notacje symboliczne. **SPA** Notaciones simbólicas. **ITA** Notazioni simboliche.



RU Удалить заусеницы. **UKR** Видалити задирки. **ENG** Remove burrs. **DEU** Niednägel entfernen. **FRA** Enlever les bavures. **POL** Usuń zadziory. **SPA** Quitar rebabas. **ITA** Eliminare le bave. **TUR** Çapakları temizle.



RU Обломать с двух сторон. **UKR** Обламати з двох сторін. **ENG** Break off from both sides. **DEU** Brechen Sie einen Zahnstocher auf beiden Seiten ab. **FRA** Casser un cure-dent des deux côtés. **POL** Oblomaj wykałaczkę po obu stronach. **SPA** Romper un palillo de dientes en ambos lados. **ITA** Rompere uno stecchino su entrambi i lati.



RU Сборка в зеркальном отражении. **UKR** Збірка в дзеркальному відображенні. **ENG** Assembly in mirror reflection. **DEU** Montage in spiegelreflexion. **FRA** Assemblage en réflexion spéculaire. **POL** Montaż w odbiciu lustrzanym. **SPA** Montaje en reflexión especular. **ITA** Assemblaggio in riflessione speculare.

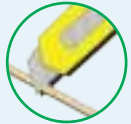

RU Отрезать зубочистку. **UKR** Відрізати зубочистку. **ENG** Cut off a toothpick. **DEU** Schneiden Sie einen Zahnstocher ab. **FRA** Couper la cure-dent. **POL** Odetniij wykałaczkę. **SPA** Cortar un palillo de dientes. **ITA** Tagliare lo stecchino.



RU Обратит внимание! **UKR** Звернути увагу! **ENG** Note! **DEU** Aufgepasst! **FRA** Faites attention! **POL** Uwaga! **SPA** ¡Presta atención! **ITA** Presta attenzione!



RU Смазать парафином. **UKR** Змастити парафіном. **ENG** Lubricate with paraffin. **DEU** Mit dem Paraffin schmieren. **FRA** Lubrifier à la paraffine. **POL** Nasmaruj parafiną. **SPA** Lubricar con parafina. **ITA** Lubrificare con paraffina.



RU Сборка окончена. **UKR** Збірка закінчена. **ENG** Assembly is completed. **DEU** Montage abgeschlossen. **FRA** Assemblée terminée. **POL** Montaż zakończony. **SPA** Ensamblaje completada. **ITA** L'assemblaggio è finito.

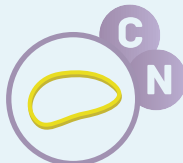

RU Большая резинка. **UKR** Велика резинка. **ENG** Large rubber band. **DEU** Großes Gummiband. **FRA** Grand élastique. **POL** Duża gumka. **SPA** Tira de goma grande. **ITA** Gomma grande. **TUR** Büyük lastik.

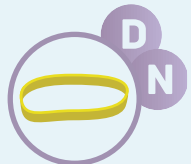

RU Широкая резинка. **UKR** Широка резинка. **ENG** Wide rubber band. **DEU** Breites Gummiband. **FRA** Large bande élastique. **POL** Szeroka gumka. **SPA** Banda de goma ancha. **ITA** Ampio elastico.

RU Внимание! Для корректной работы данной модели, необходимо при сборке тщательно зачищать и смазывать парафином все трущиеся детали. Все механизмы должны свободно вращаться. **UA** Увага! Для коректної роботи даної моделі, необхідно при збірці ретельно зачищати, змащувати парафіном усі деталі, які труться. **EN** Warning! For the correct operation of this model, it is necessary to clean carefully and to lubricate all rubbing parts with paraffin during assembly. All mechanisms must rotate freely. **FR** Attention ! Pour le bon fonctionnement de ce modèle, il est nécessaire lors du montage de nettoyer et lubrifier soigneusement toutes les pièces à friction avec de la paraffine. Tous les mécanismes doivent tourner librement. **SP** ¡Atención! Para el funcionamiento adecuado de este modelo a la hora de ensamblaje se recomienda alisar y lubricar cuidadosamente con parafina todos los detalles frotantes. Todos los mecanismos deben girar libremente. **IT** Attenzione! Per il corretto funzionamento di questo modello, durante il montaggio, è necessario pulire e lubrificare accuratamente tutte le parti di sfregamento con paraffina. Tutti i meccanismi devono ruotare liberamente. **DE** Hinweis! Für einen korrekten Betrieb dieses Modells ist bei dem Zusammenbau erforderlich, alle Reibteile sorgfältig auszusmiegeln und mit Paraffin zu schmieren. Alle Bauteile sollen sich frei drehen. **PL** Uwaga! Aby ten model działał prawidłowo, podczas montażu wszystkie detale trące muszą być dokładnie oczyszczone i nasmarowane parafiną. Wszystkie mechanizmy muszą się swobodnie obracać.



RU Взвести механизм. **UKR** Звести механізм. **EN** Start the mechanism. **DE** Starten Sie den Mechanismus. **FR** Démarrer le mécanisme. **PL** Zapusc mechanizm. **SP** Dar vuelta el mecanismo. **IT** Avvia il meccanismo.

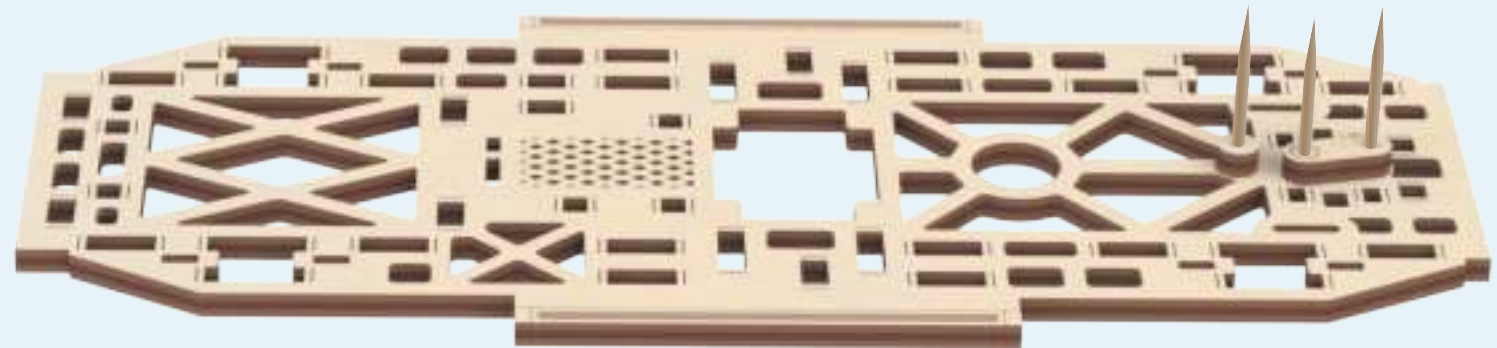
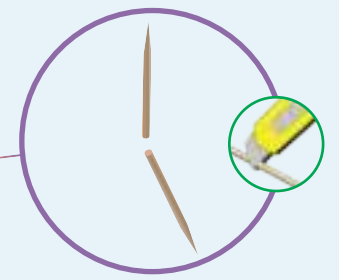
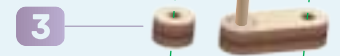
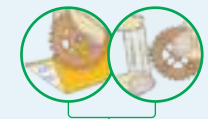
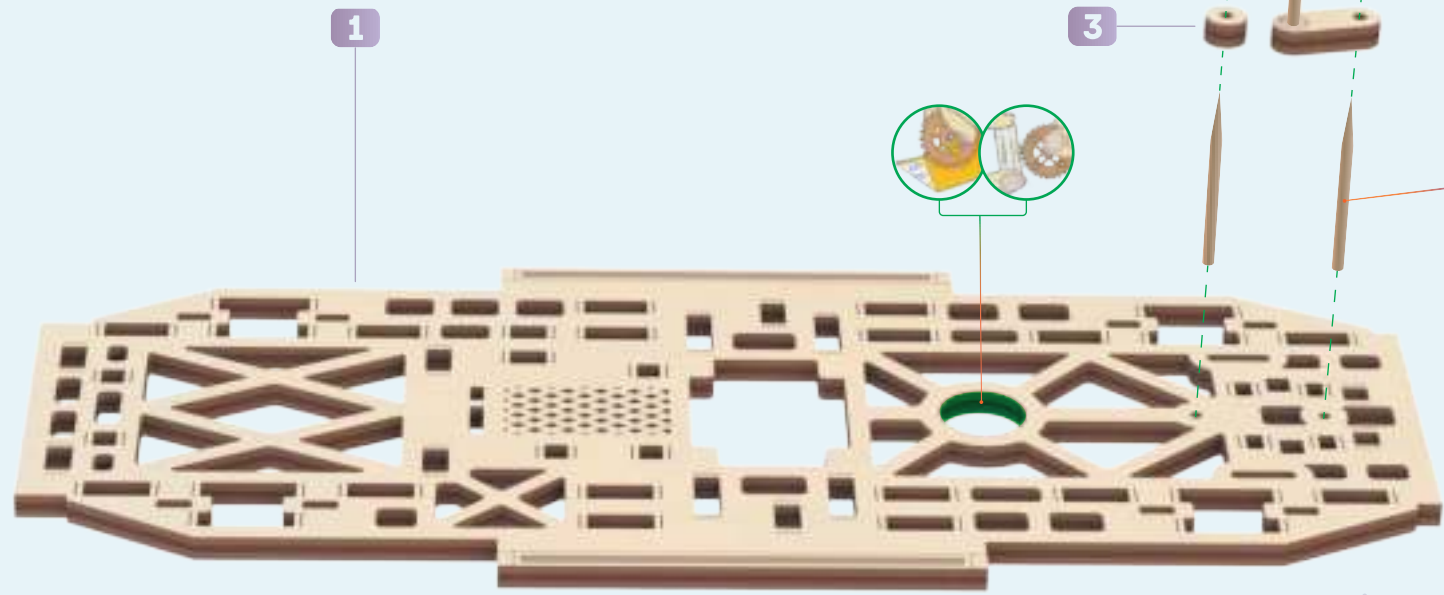
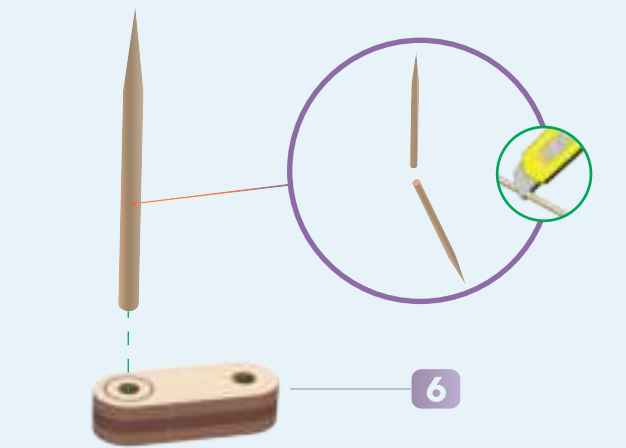

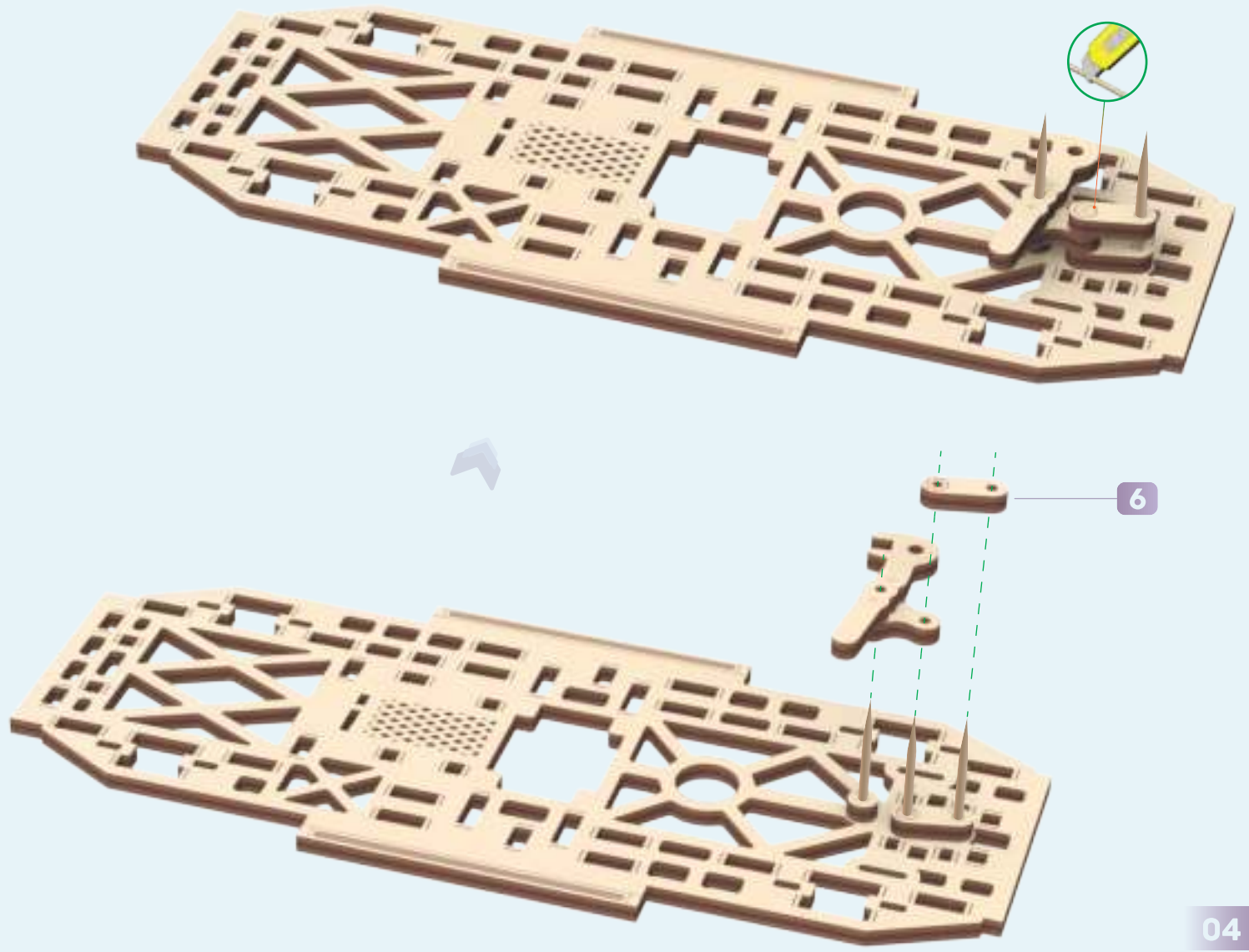
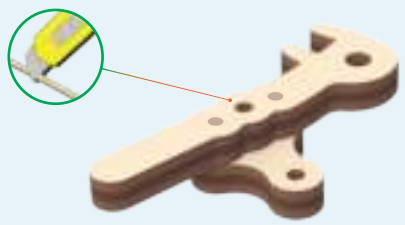
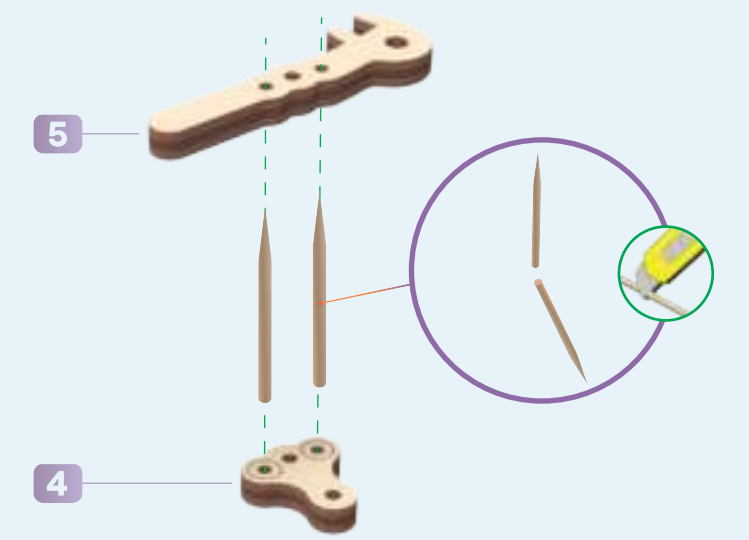

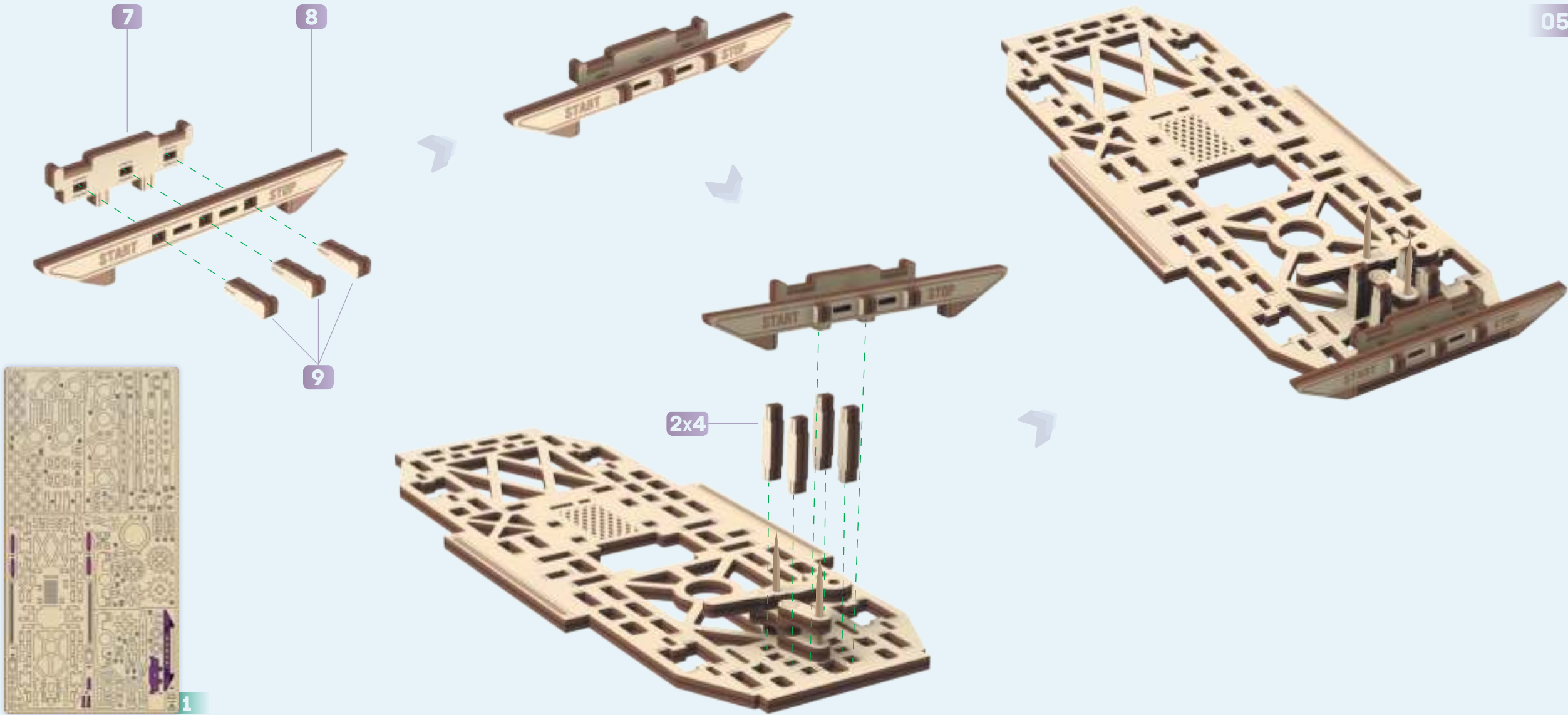

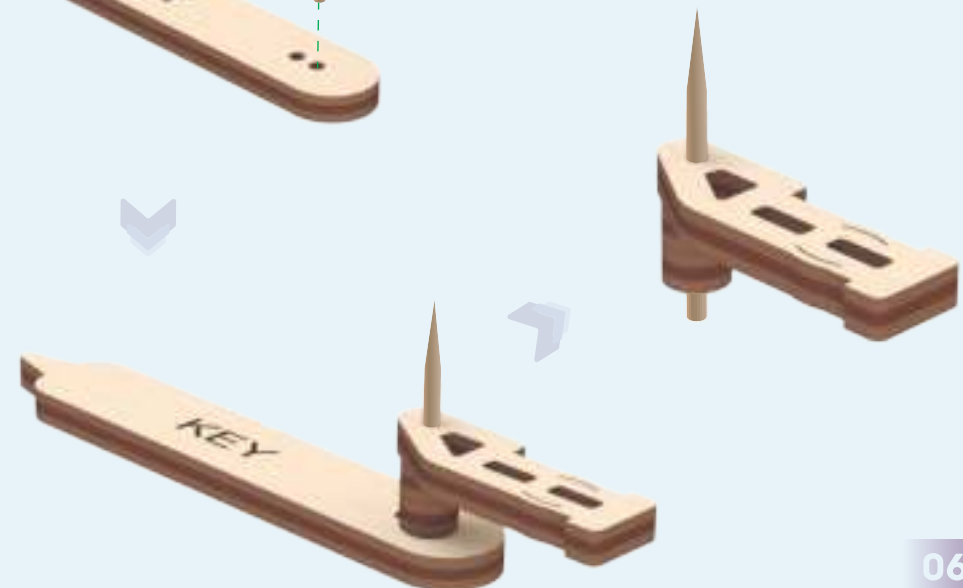
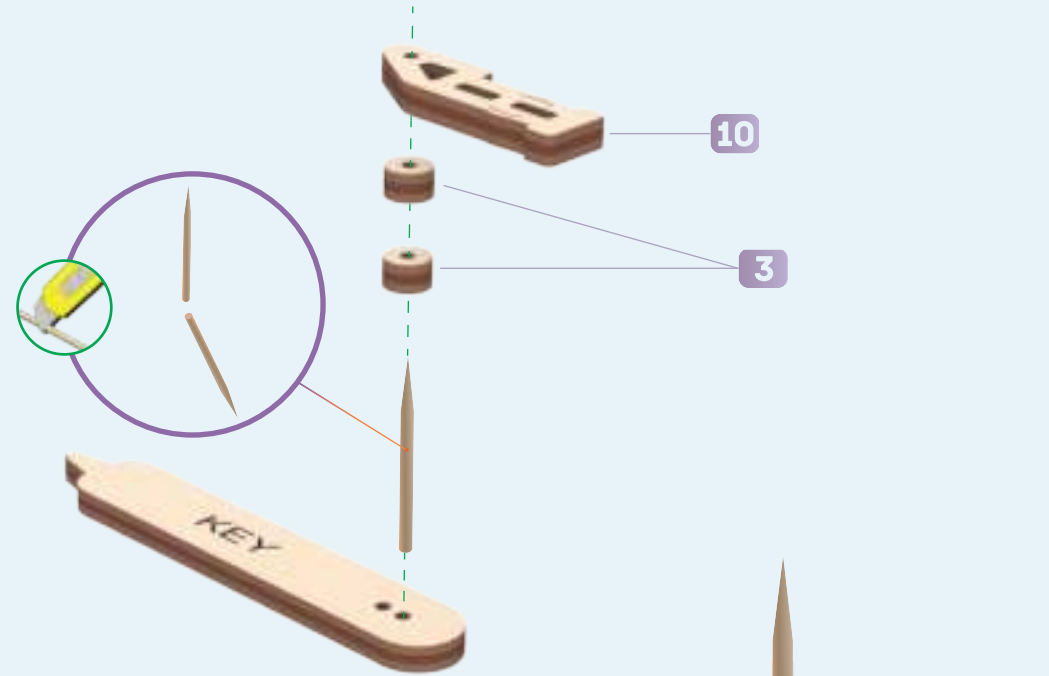
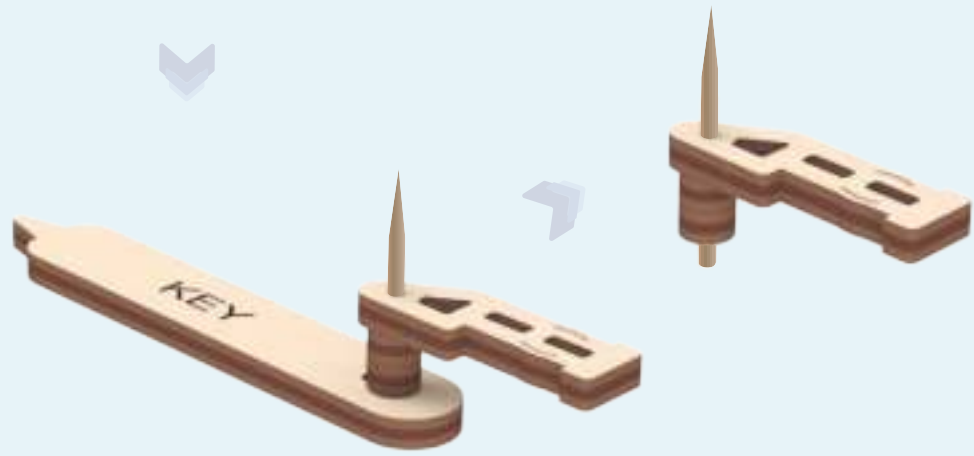
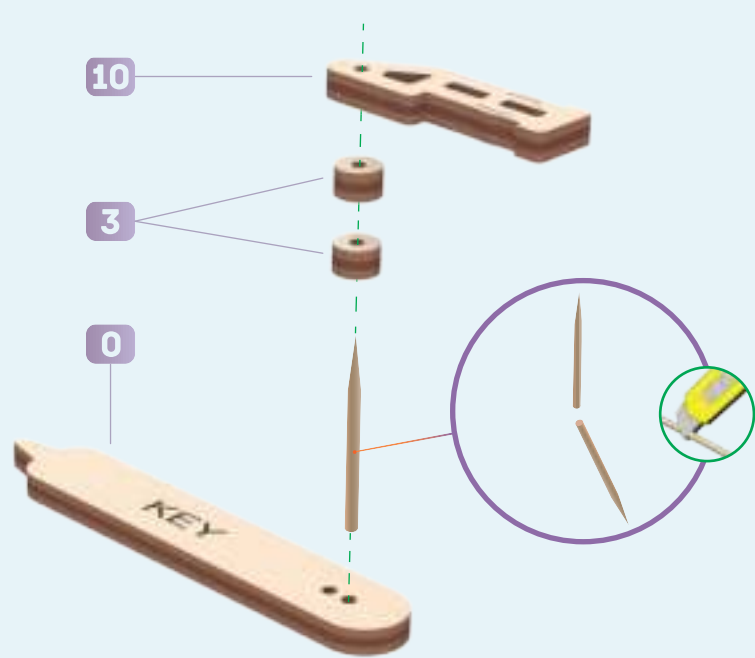



1

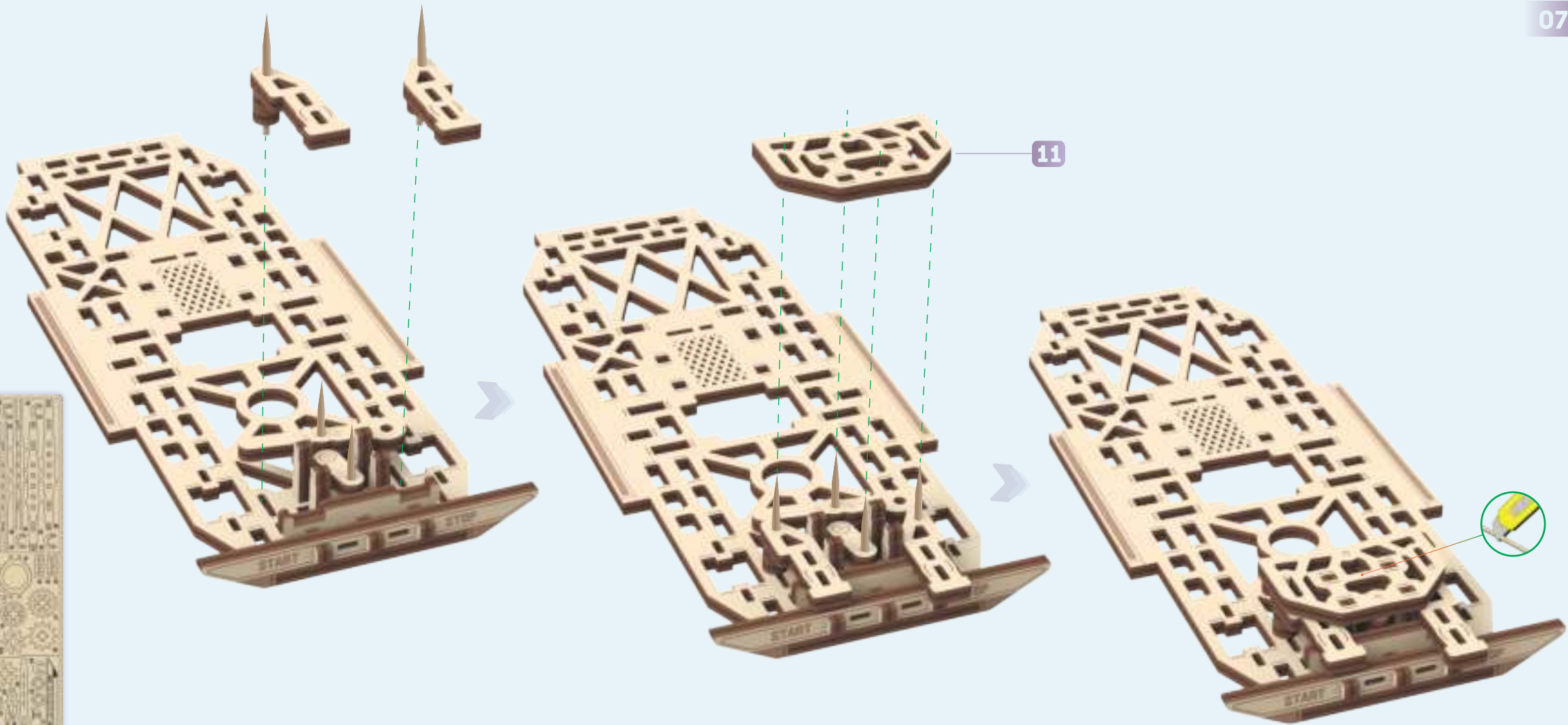

11



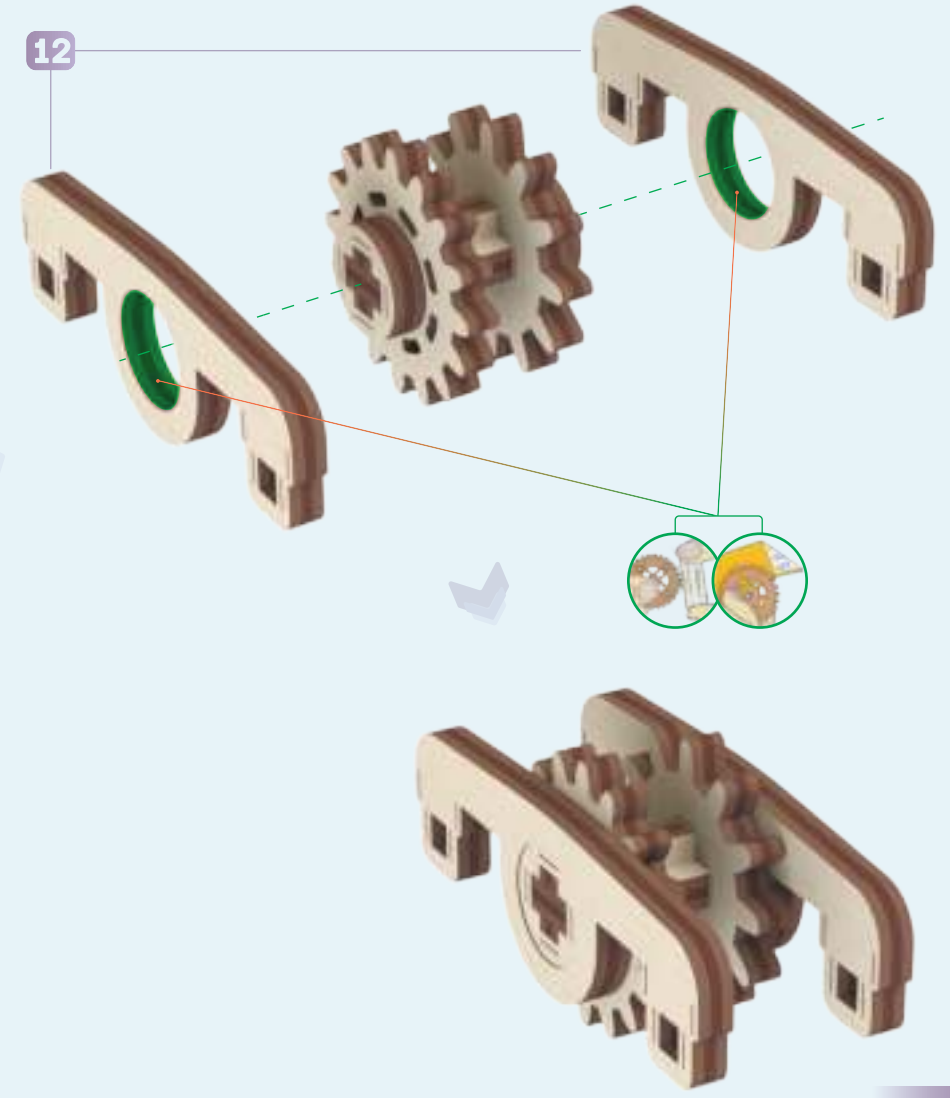
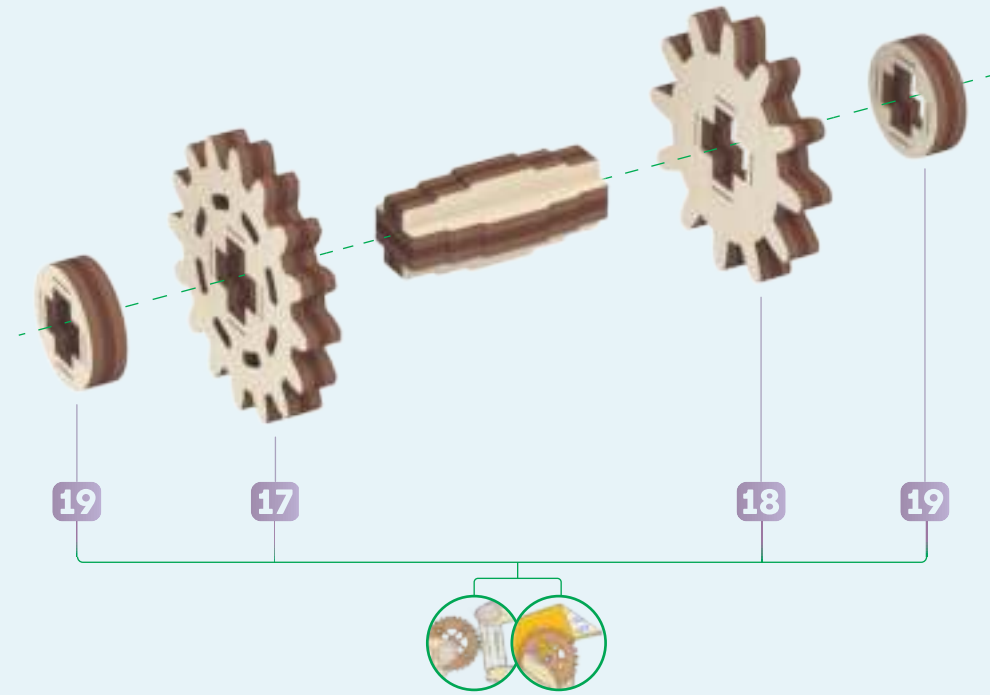
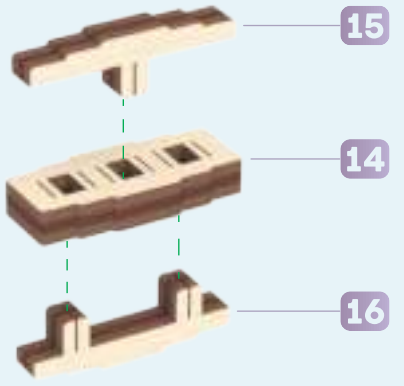

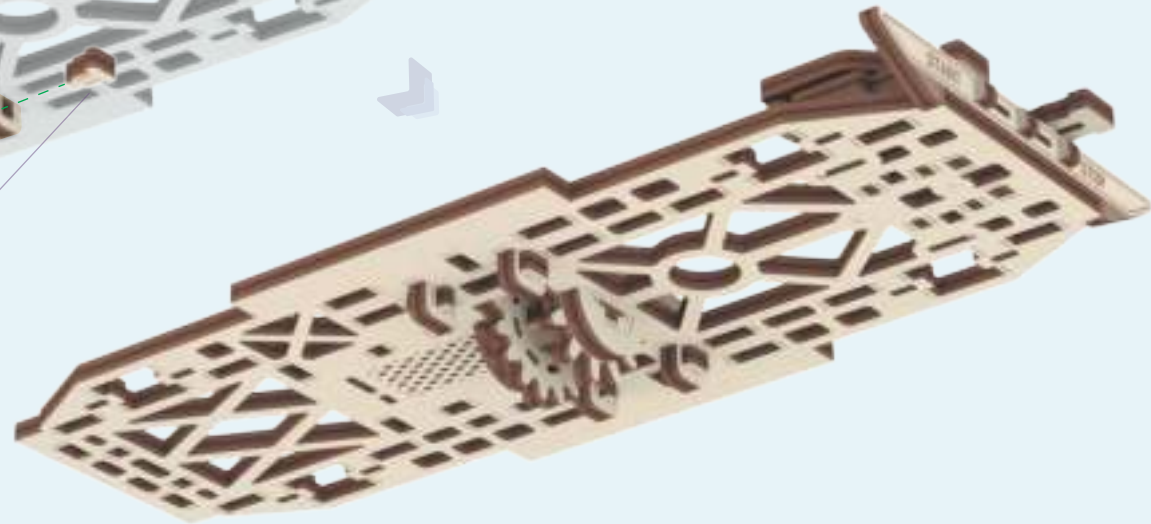
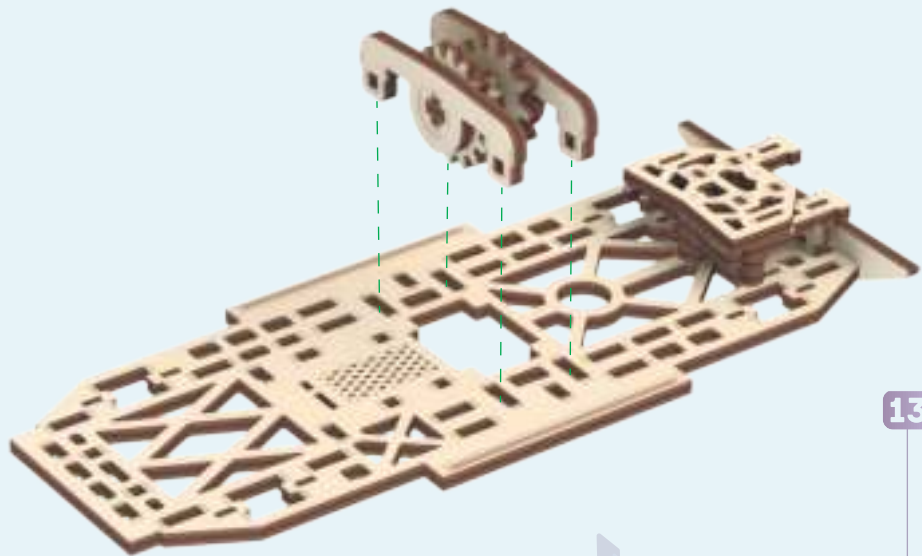

1

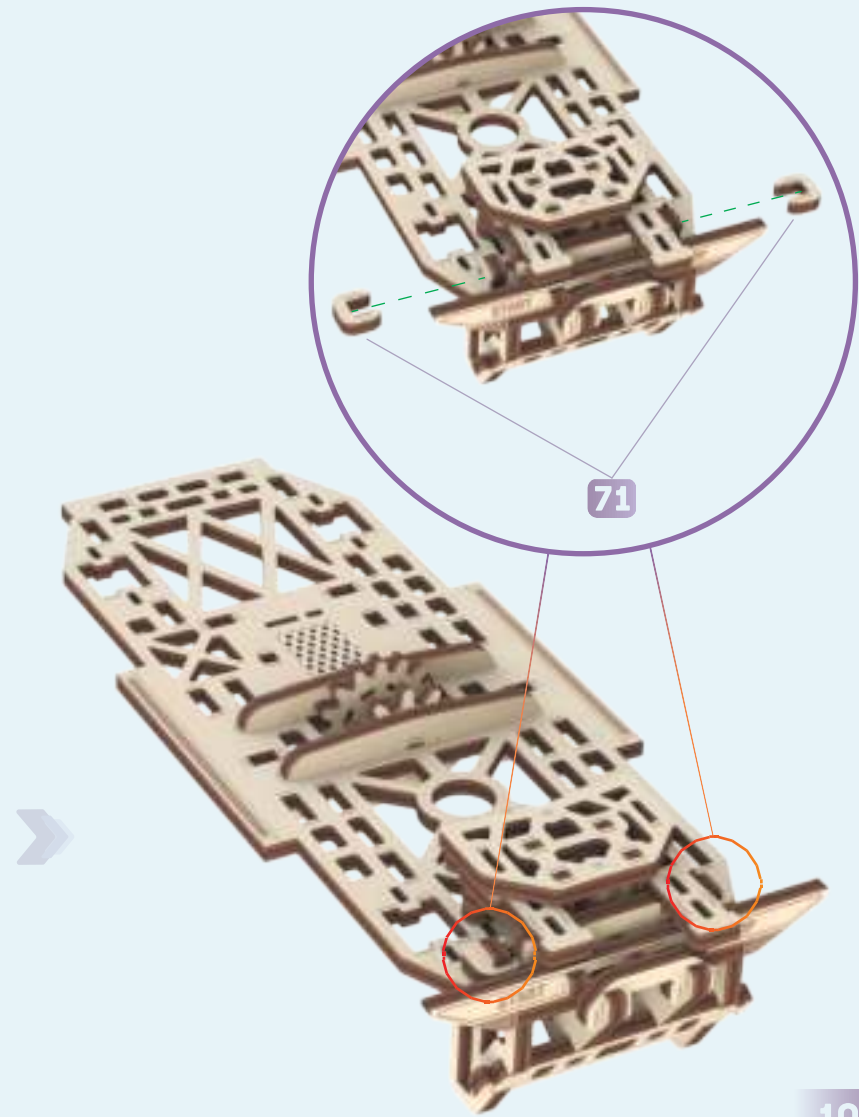
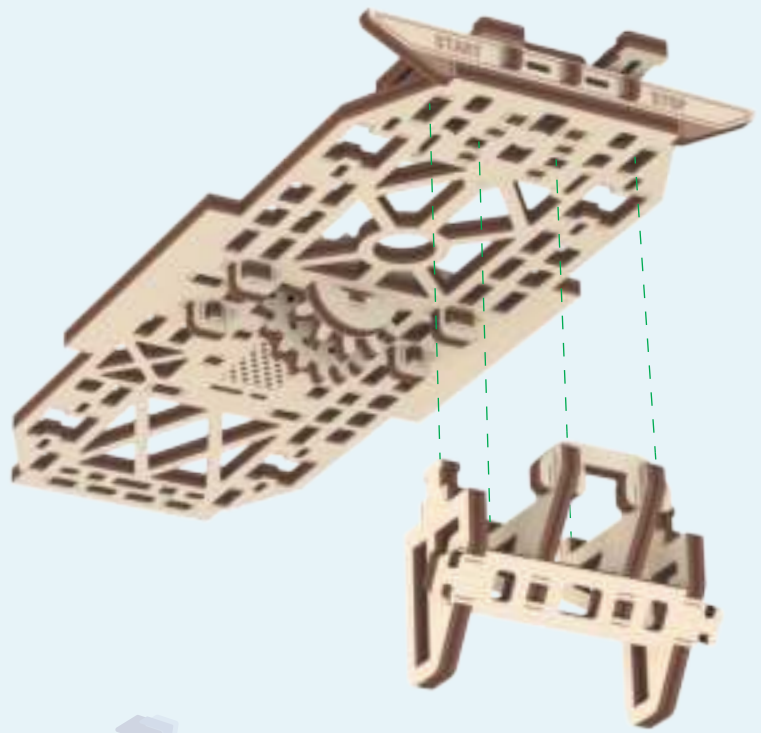
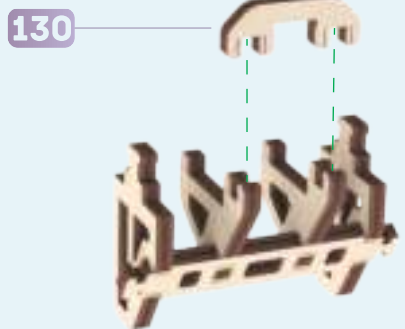
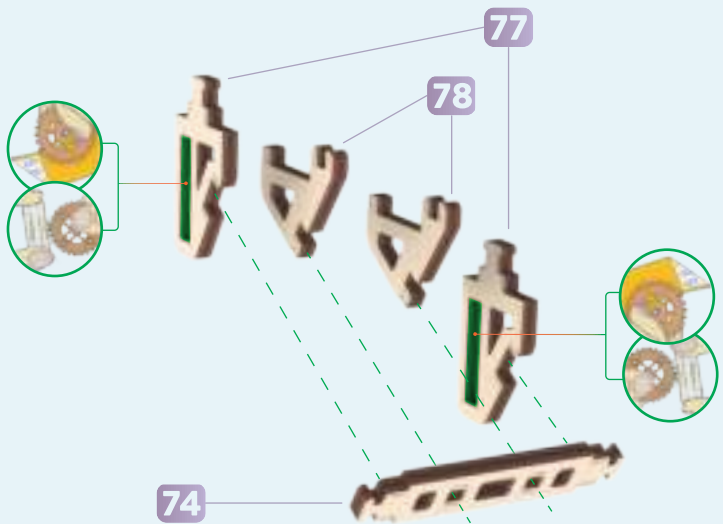

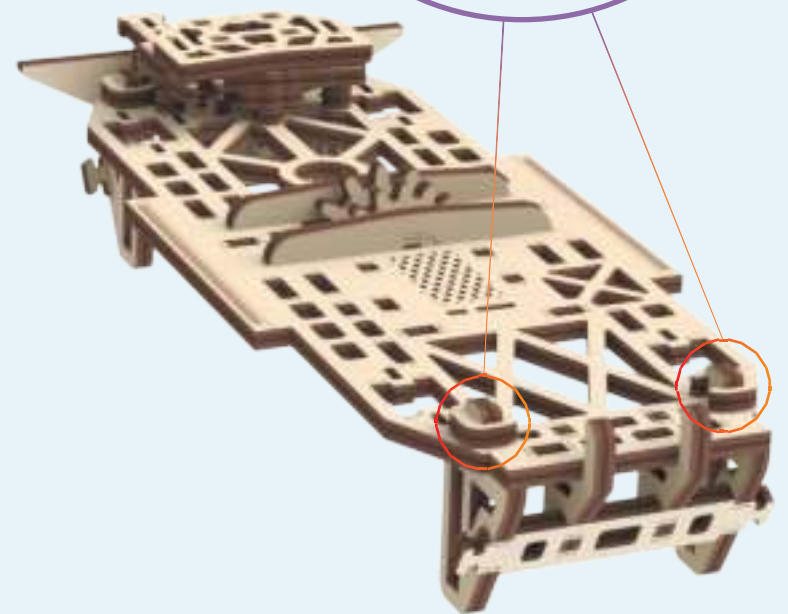
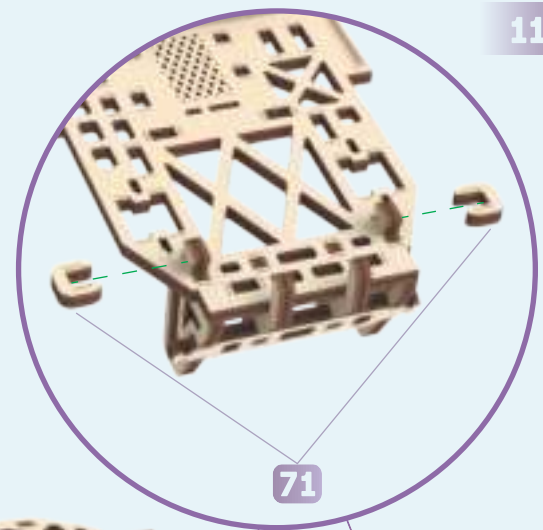
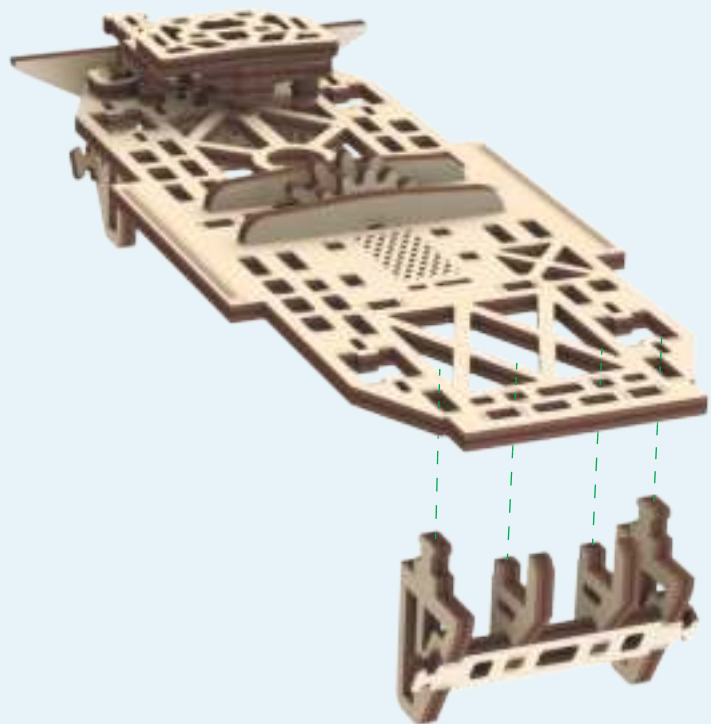
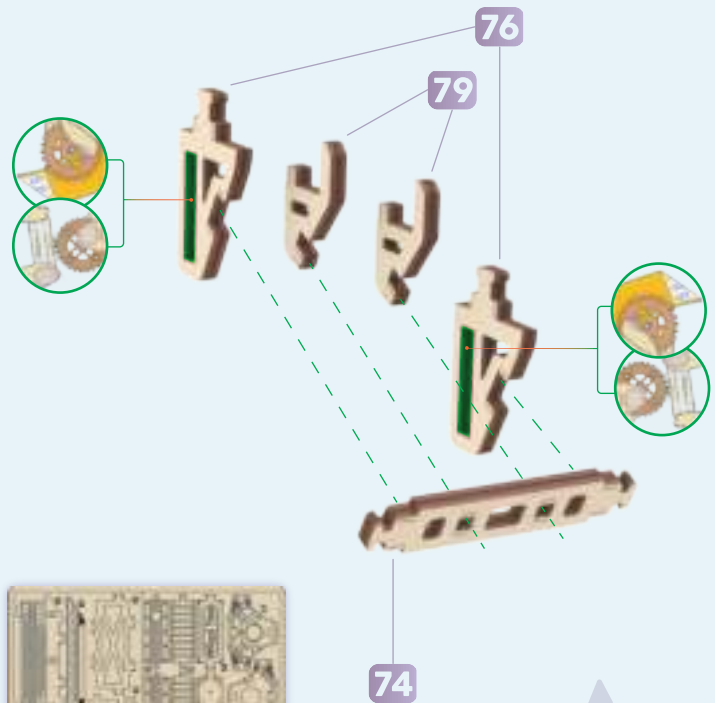

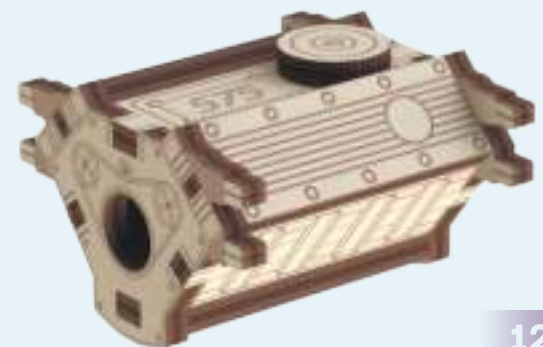
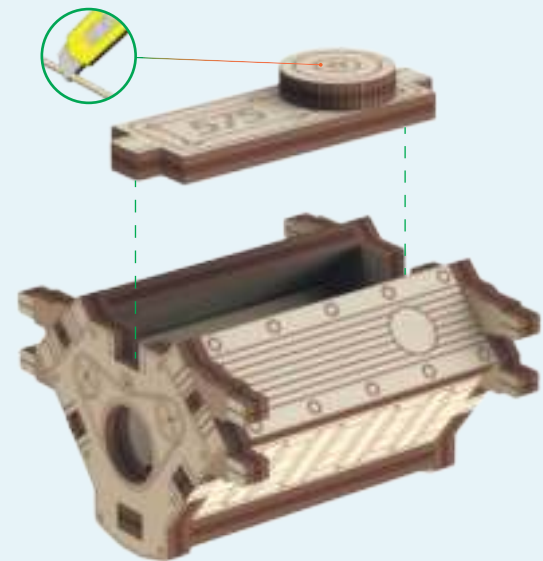
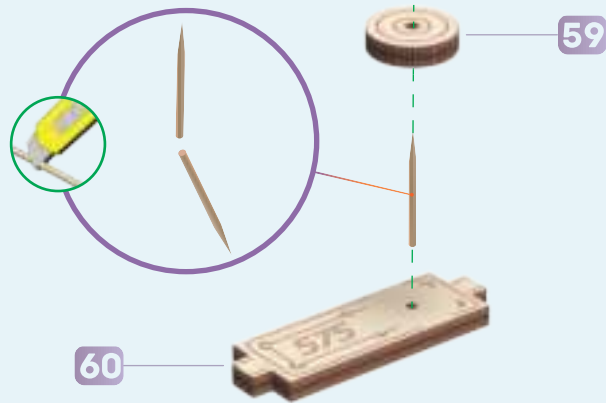
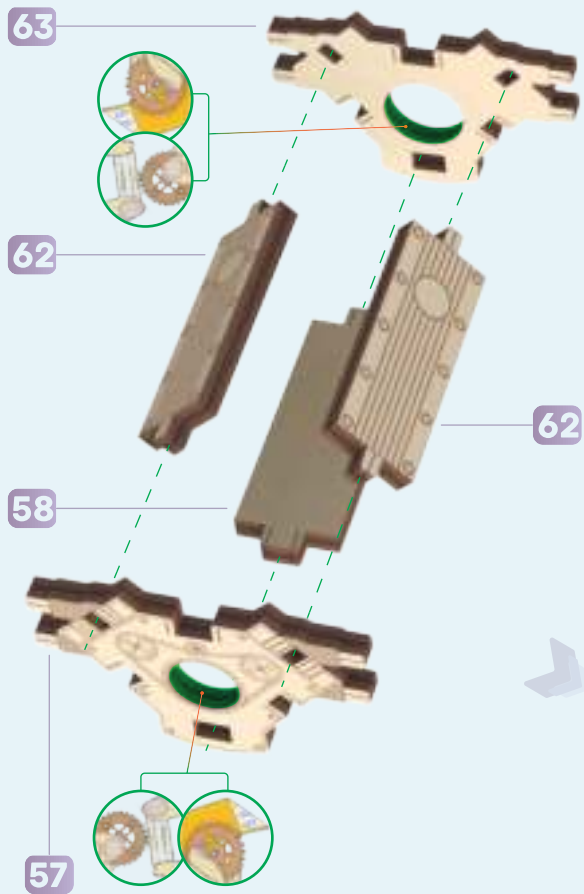
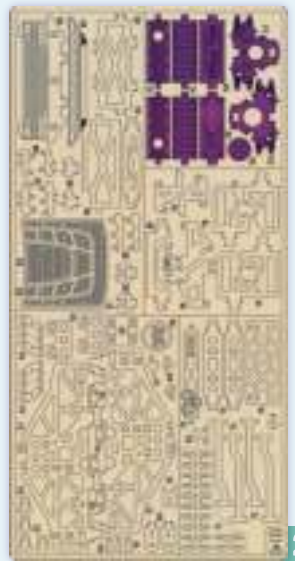



2

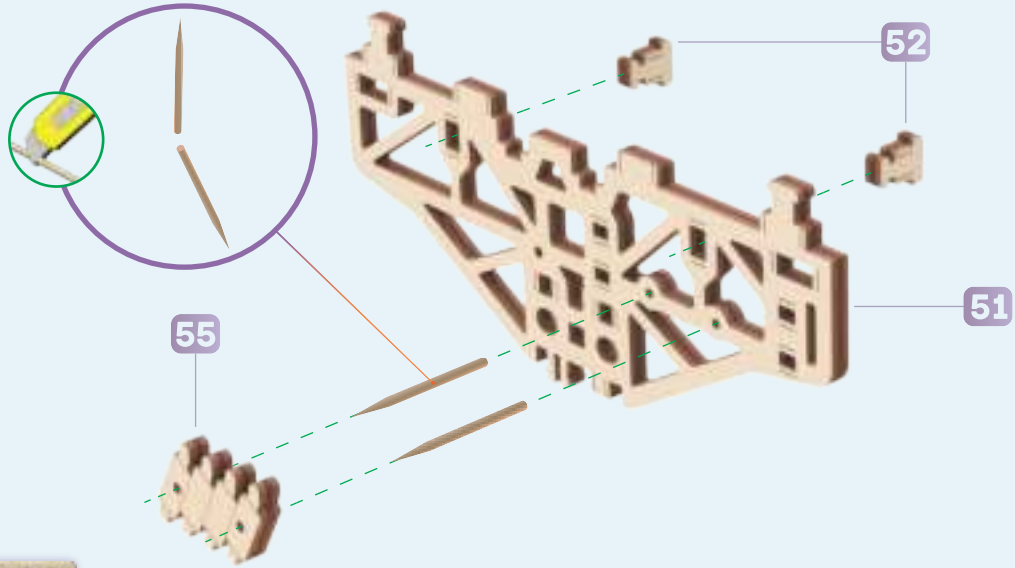

55

52

51

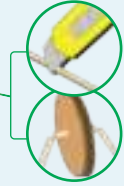
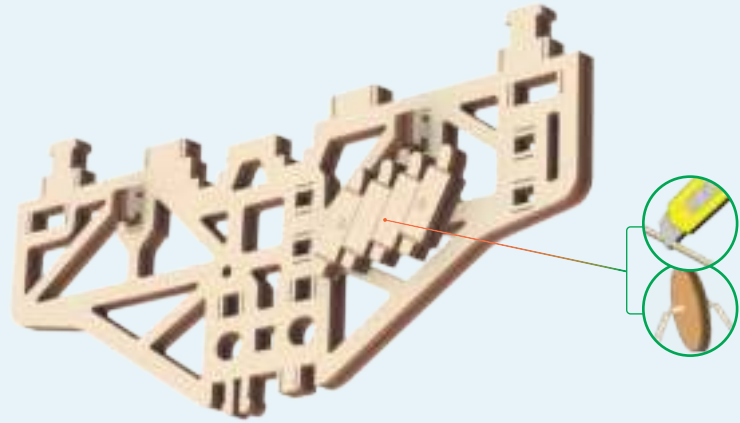

13

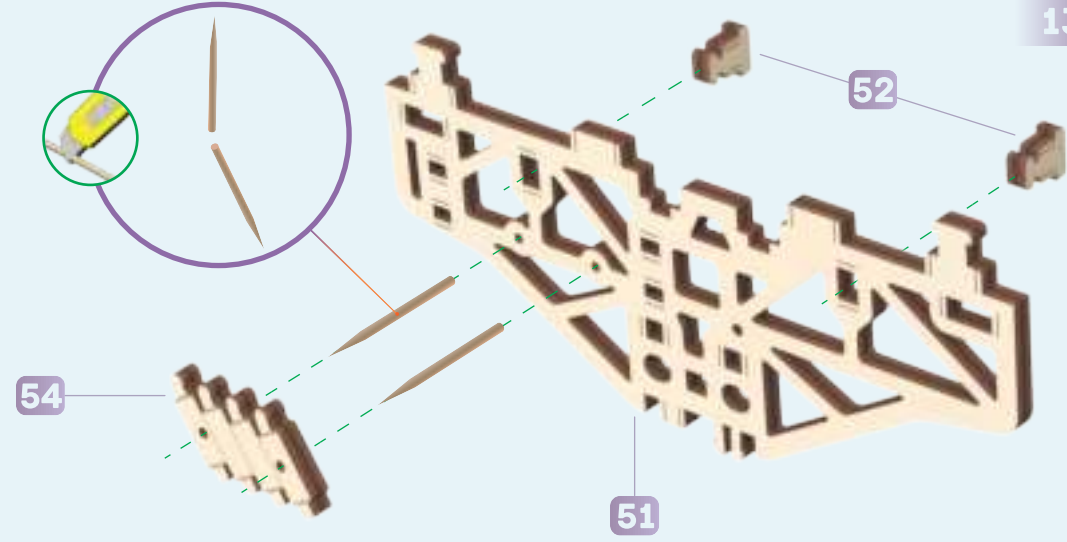

54

52

51

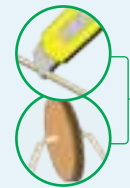
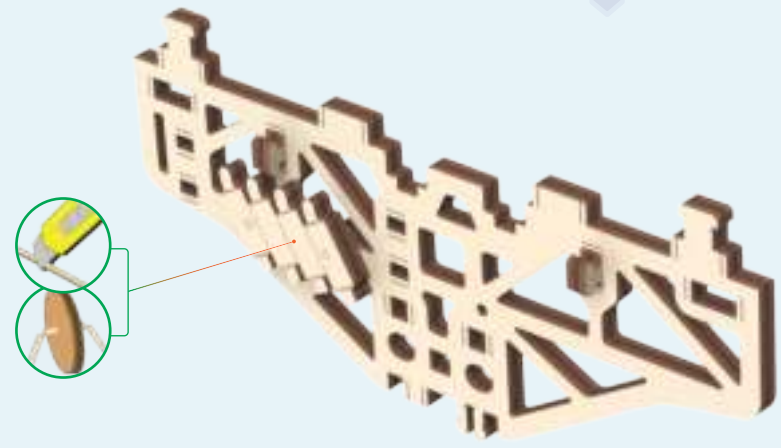

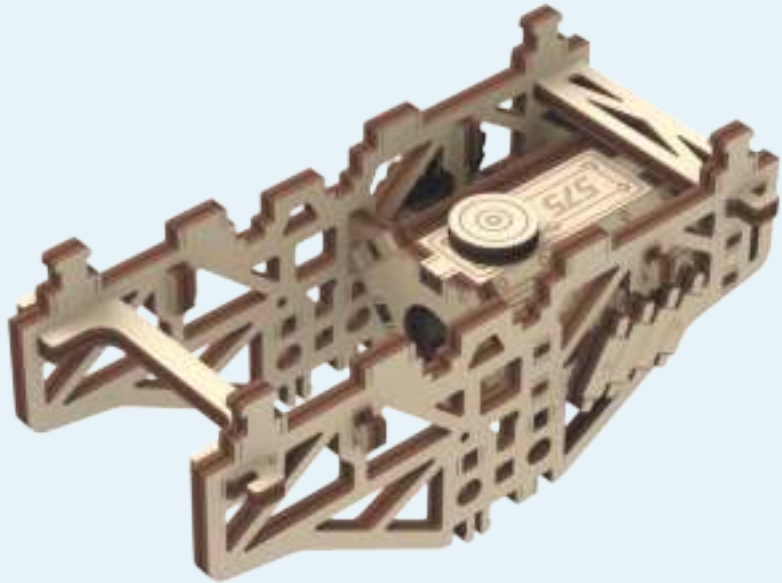
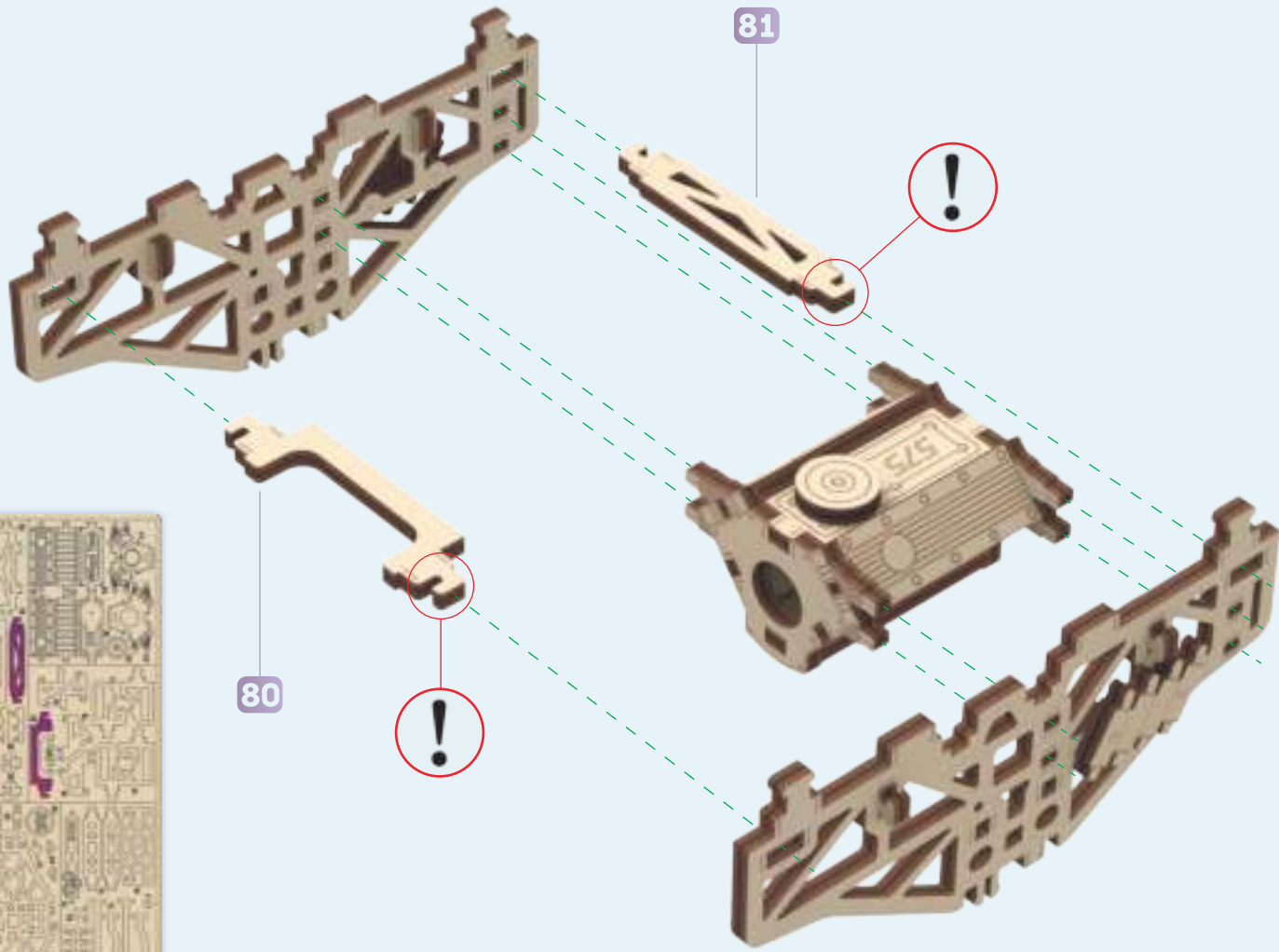

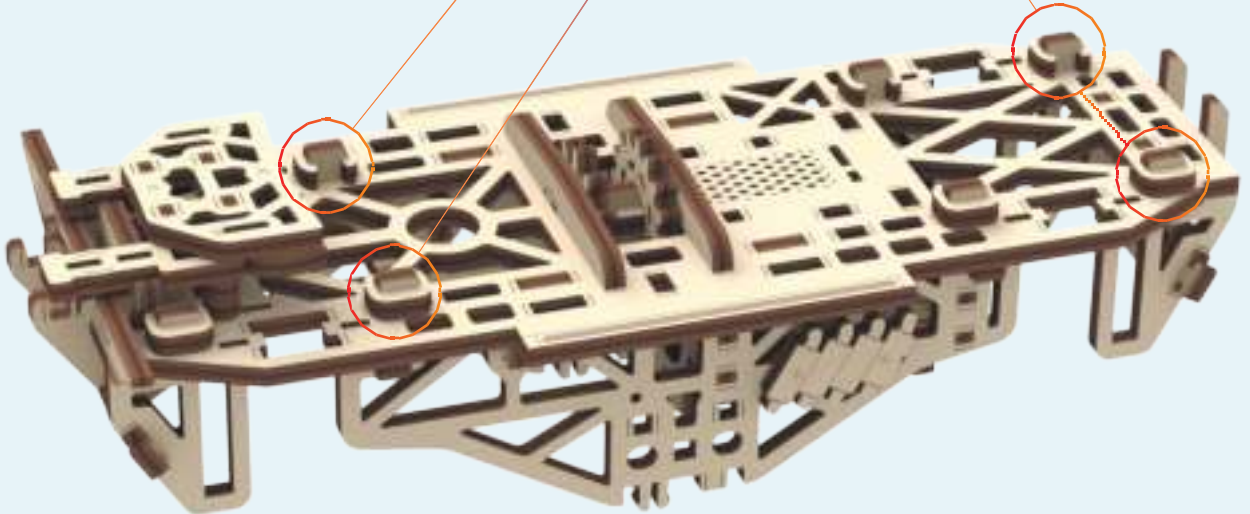
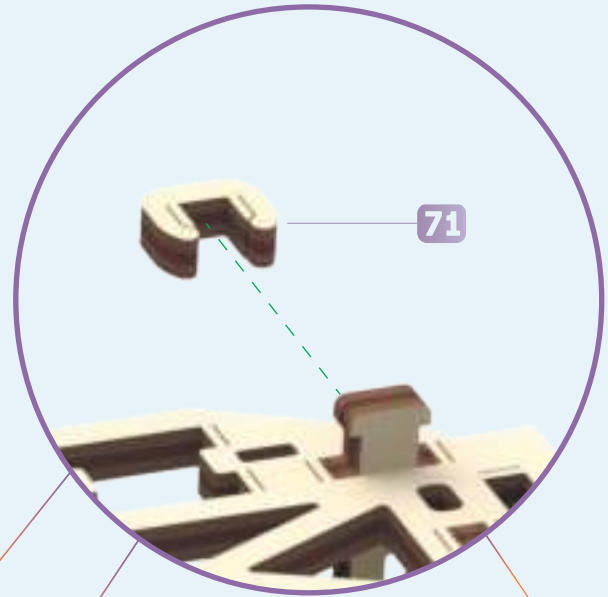
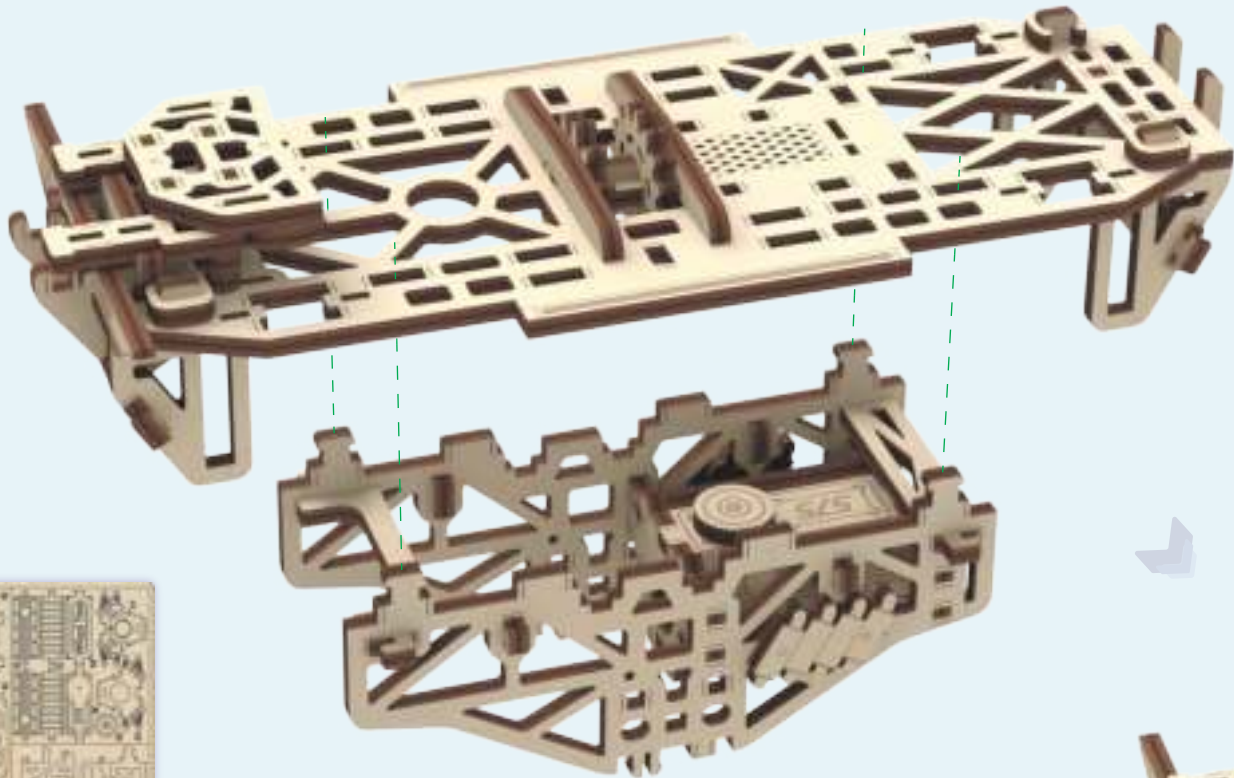



151

153



153

152



163

154



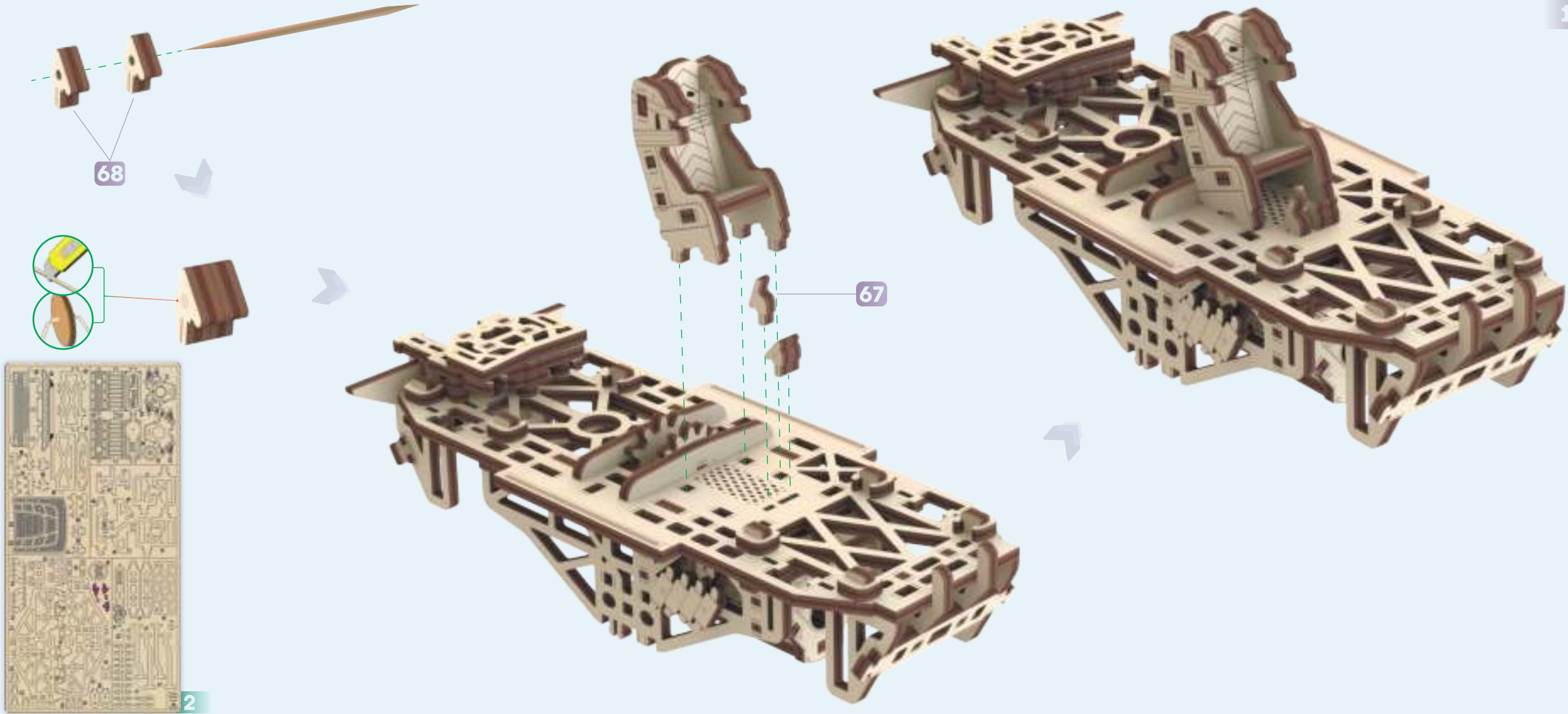



2

69



94



70



69

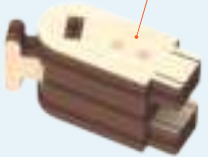
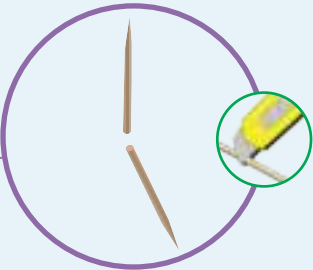



138



RU Внимание! Осторожно срежьте фиксирующую стяжку, по скольку пружина может выстрелить.

UA Увага! Обережно зрізайте фіксуючу стяжку, оскільки пружина може вистрілити.

EN Attention! Cut off the fixing buckle carefully as the spring may discharge.

DE Achtung! Schneiden Sie die Halteklammer vorsichtig ab, da die Feder sich verbiegen kann.

FR Attention ! Veuillez couper soigneusement l'attache de retenue pour éviter le tirage de ressort.

IT Attenzione! Tagliare con cautela la fascetta di fissaggio perché la molla potrebbe scattare.

SP ¡Atención! Corte la barra atiesadora con cuidado ya que el resorte puede disparar.

PL Uwaga! Ostrożnie odetnij opaskę mocującą, ponieważ sprężyna może strzelić.



7

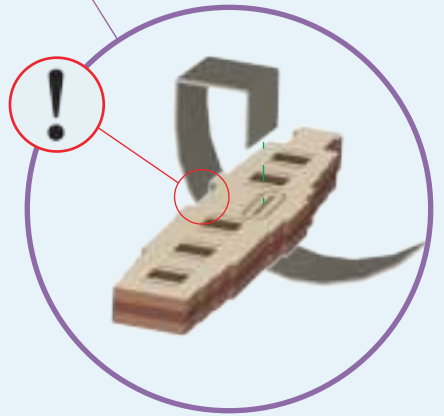

139

140



141

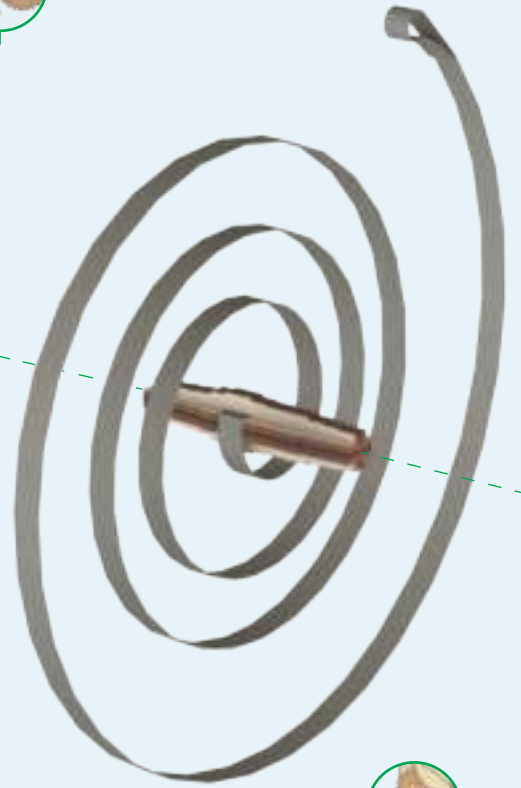

141

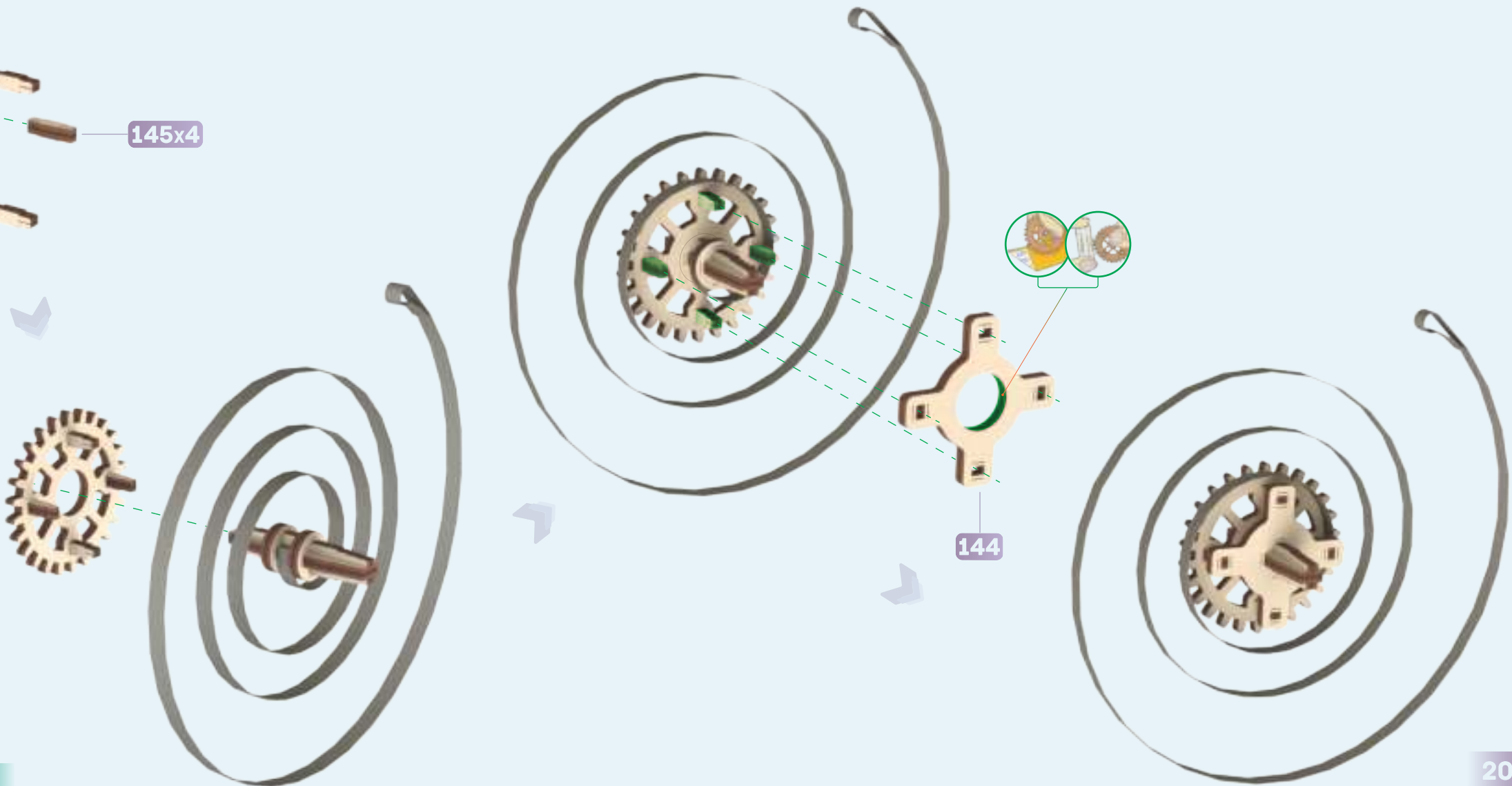
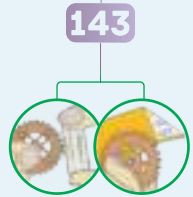
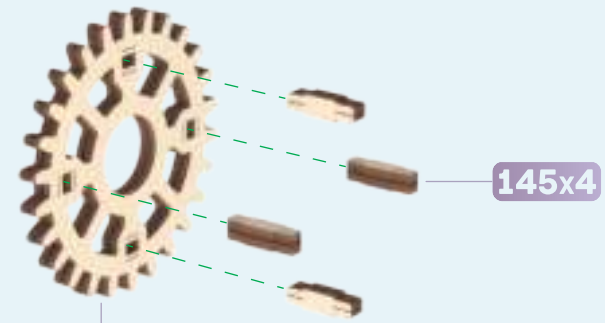

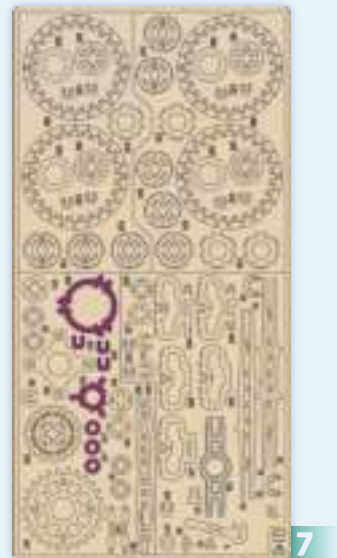
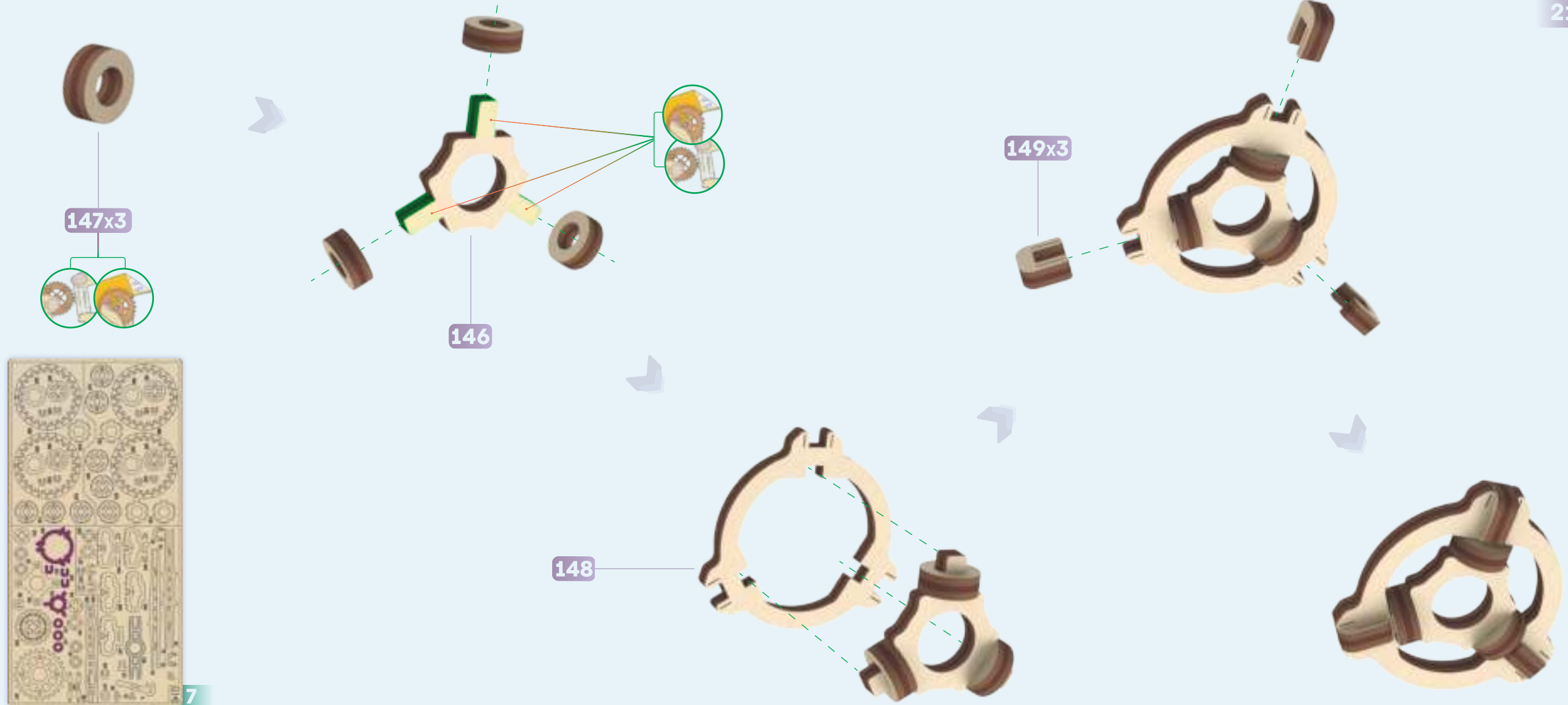



7

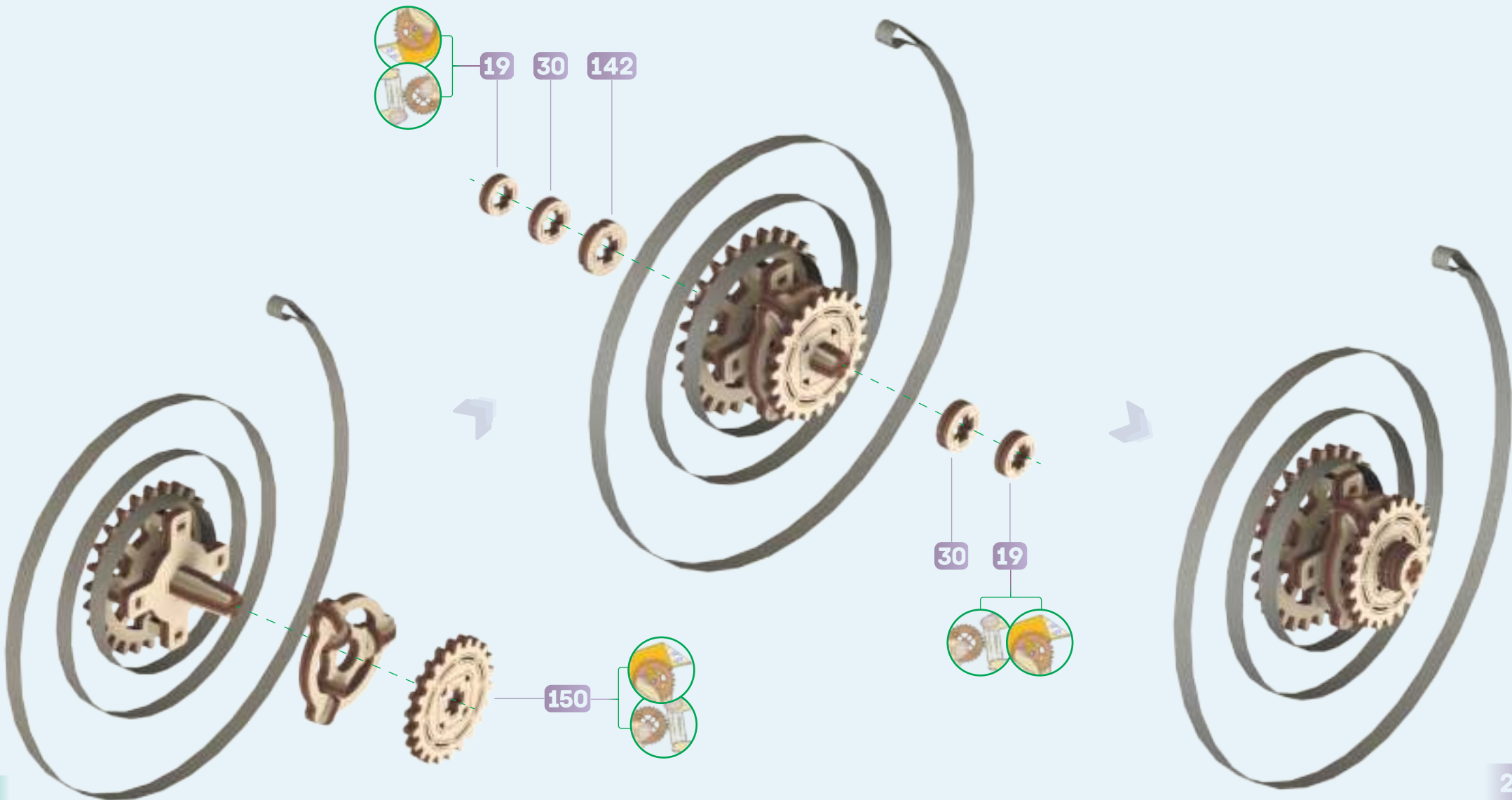





7

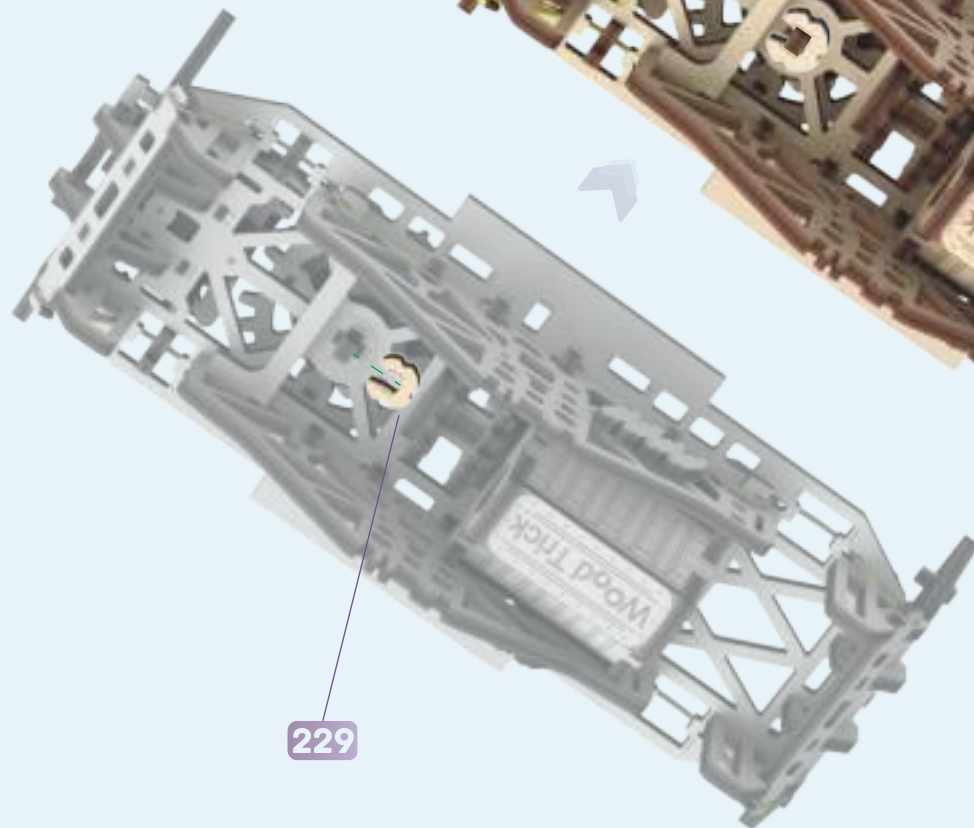

229

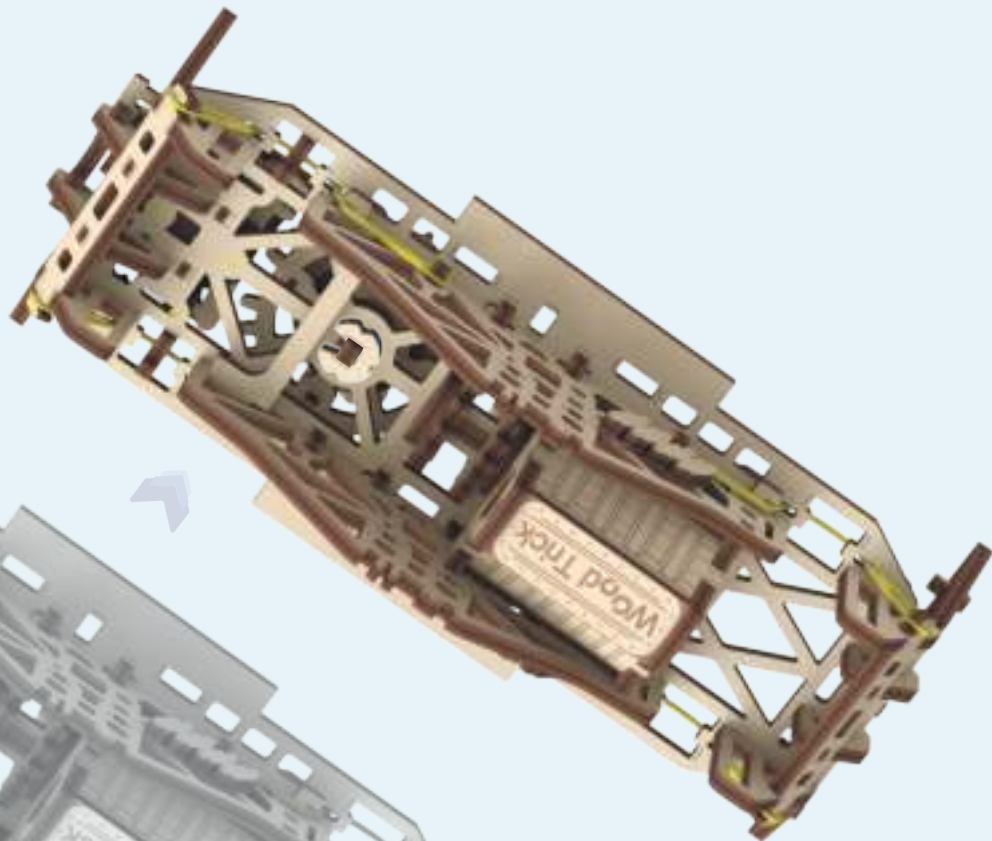

24





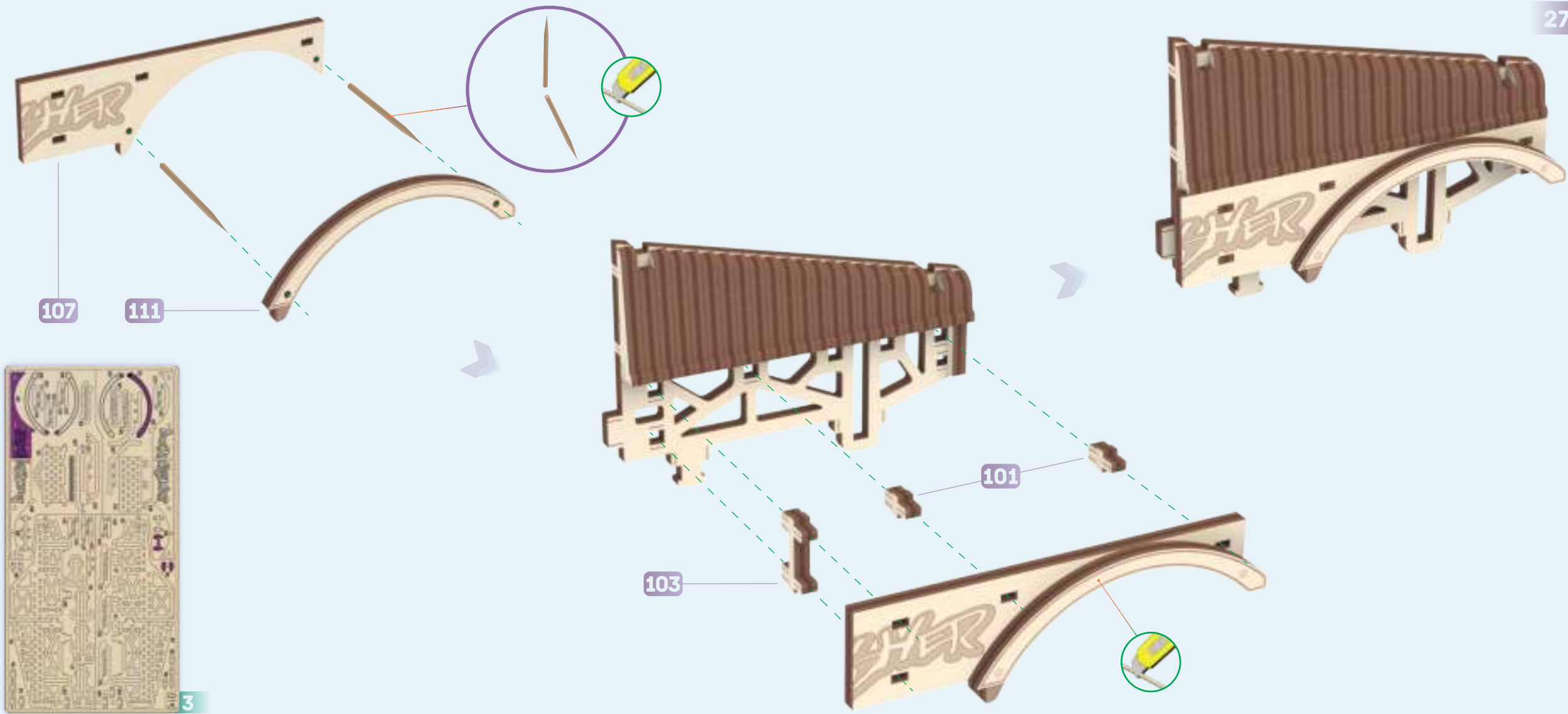

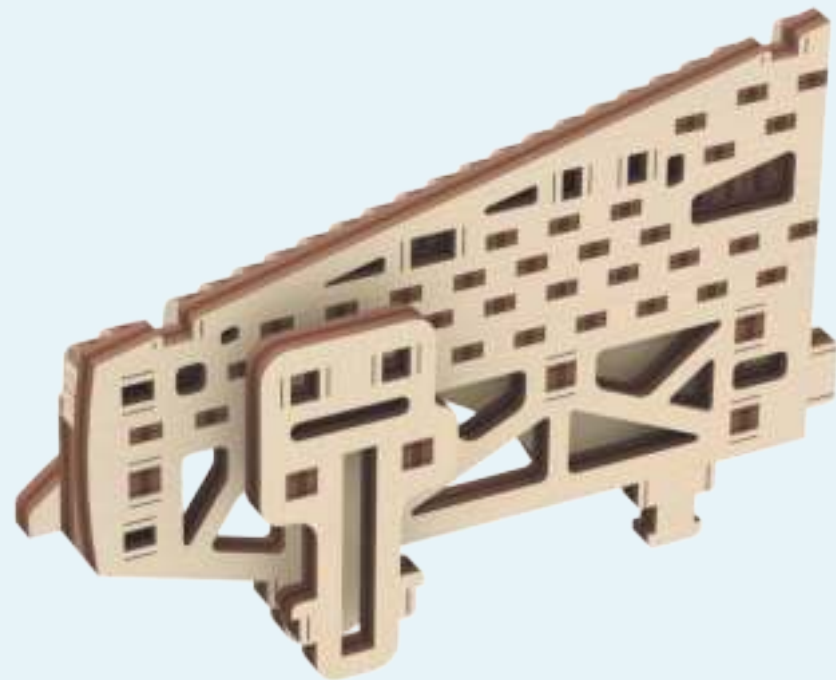
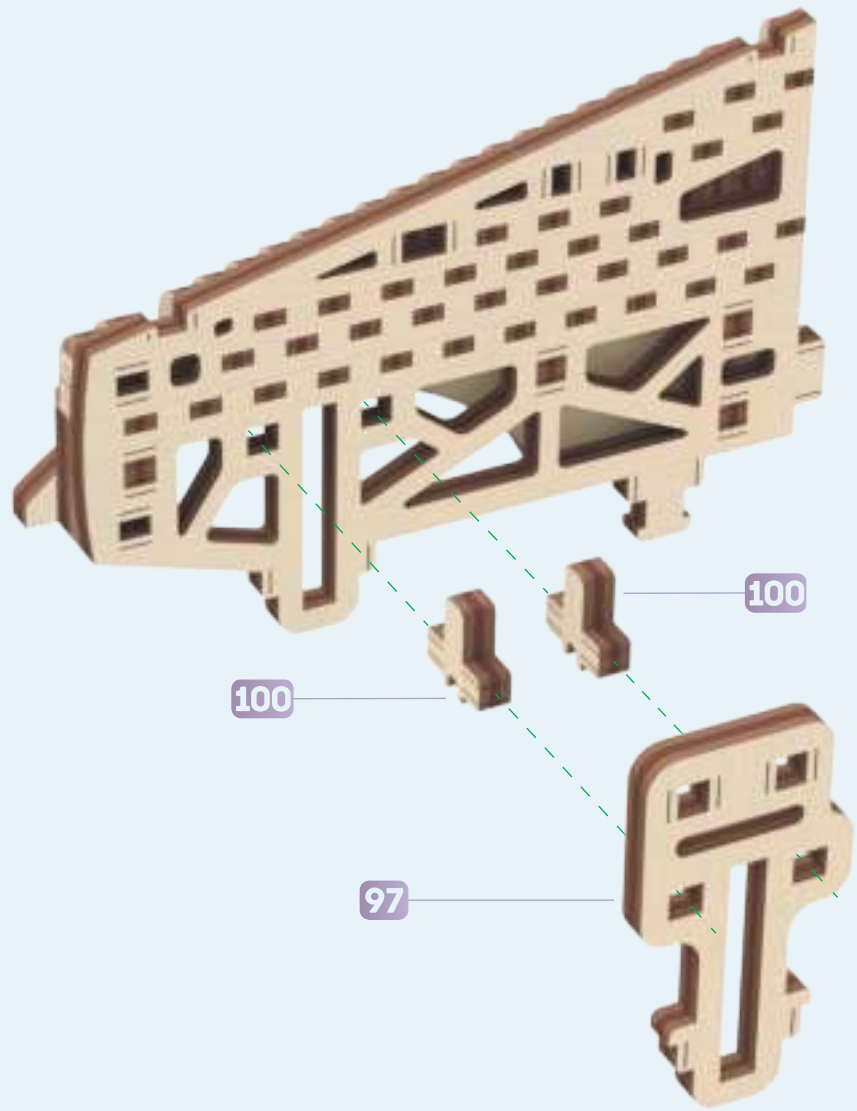

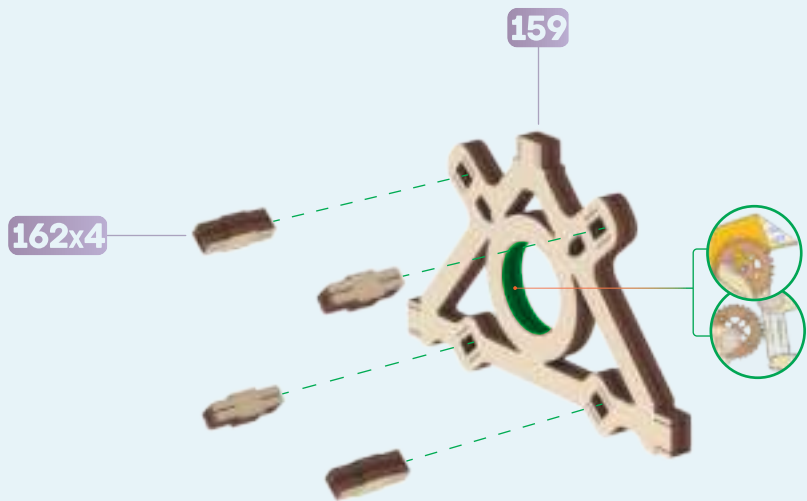
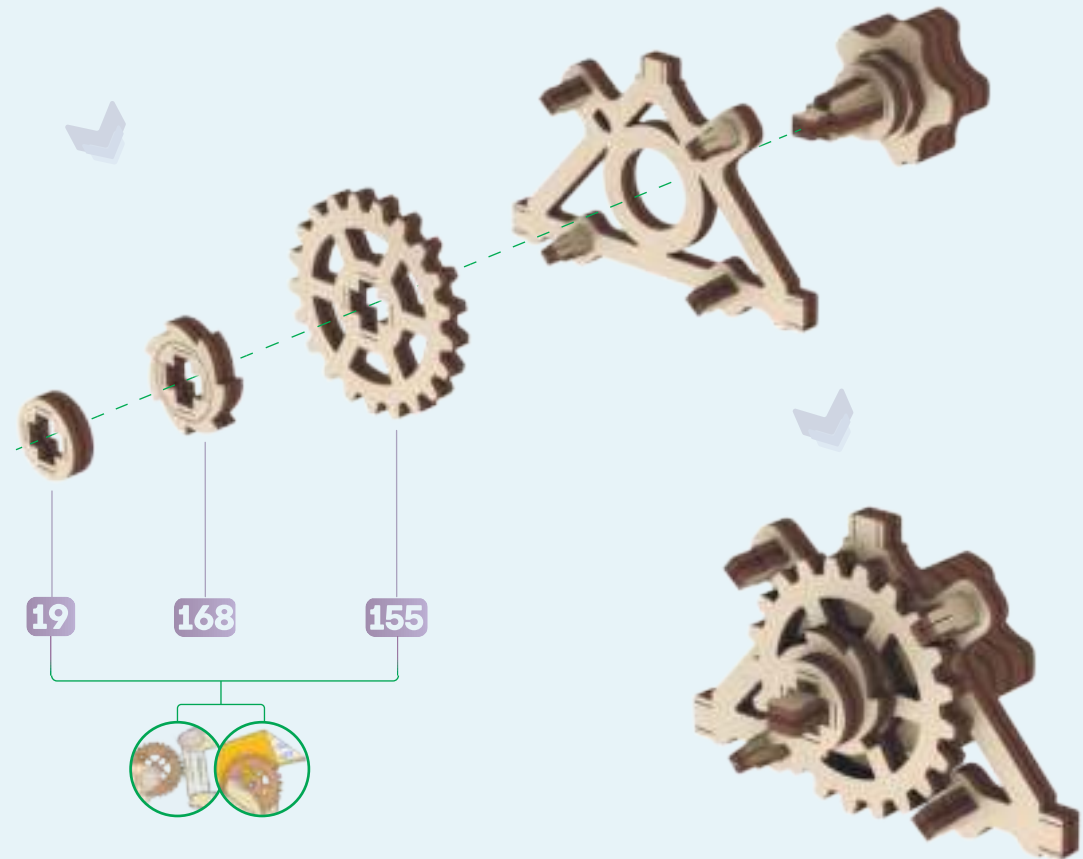
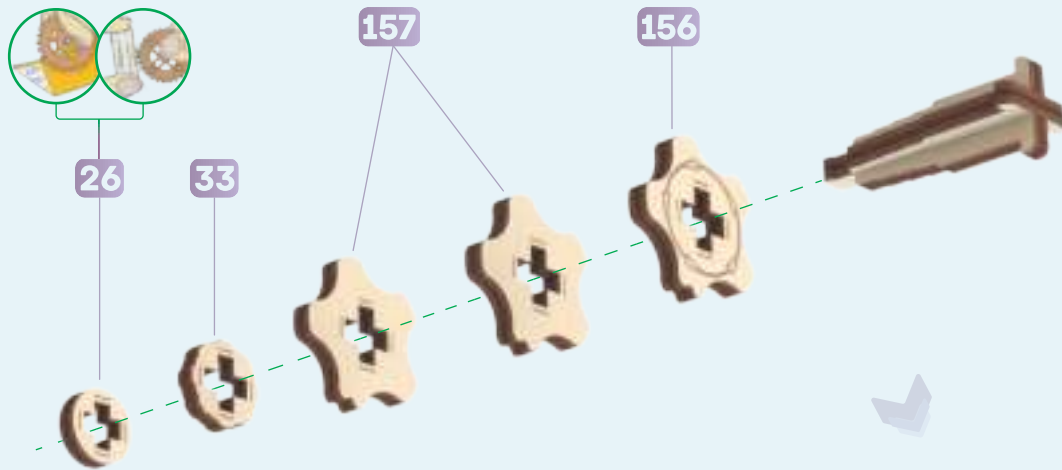
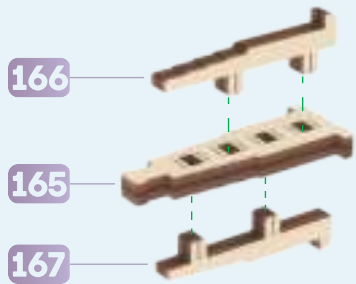

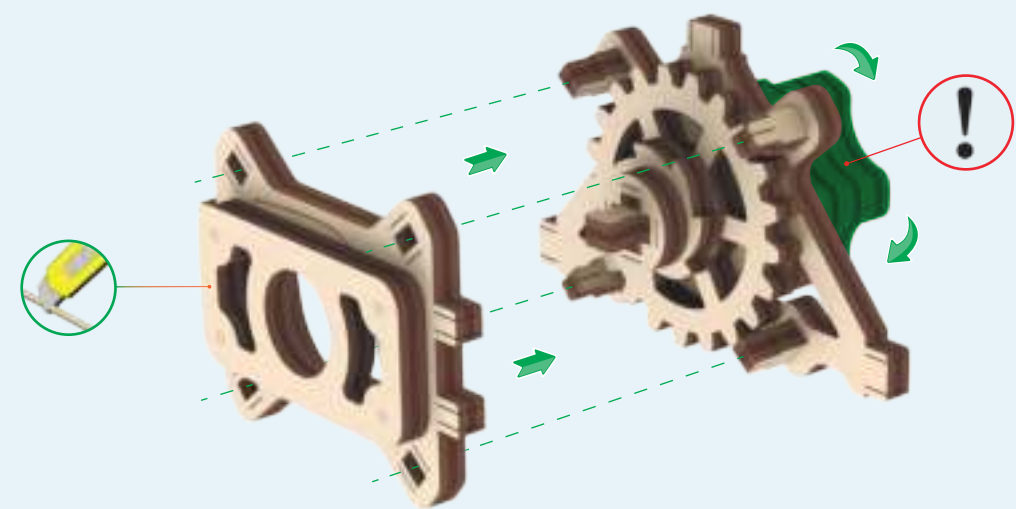
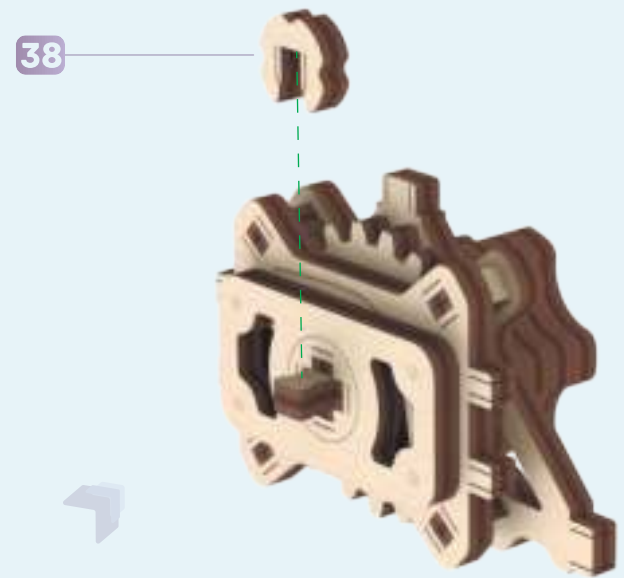
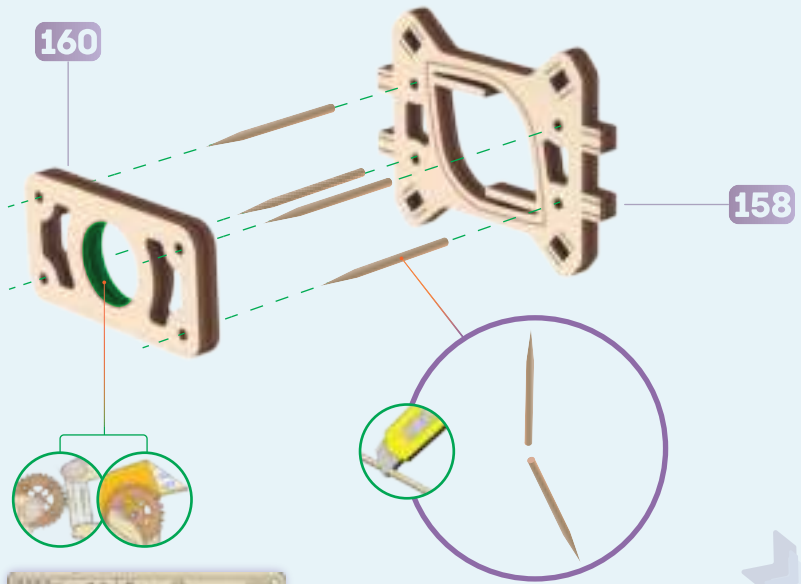



3

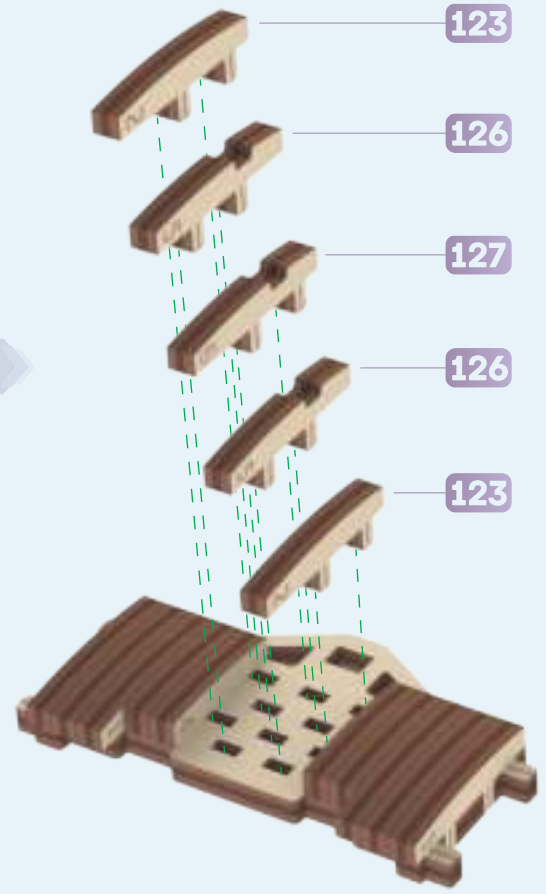
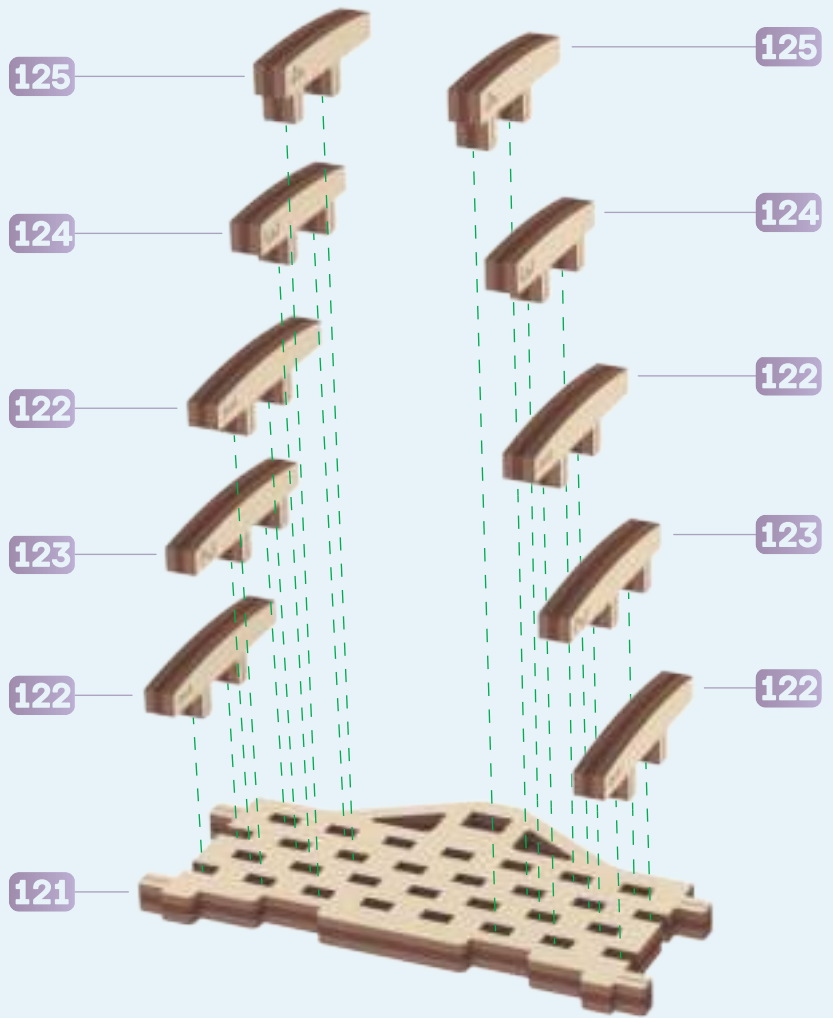



4

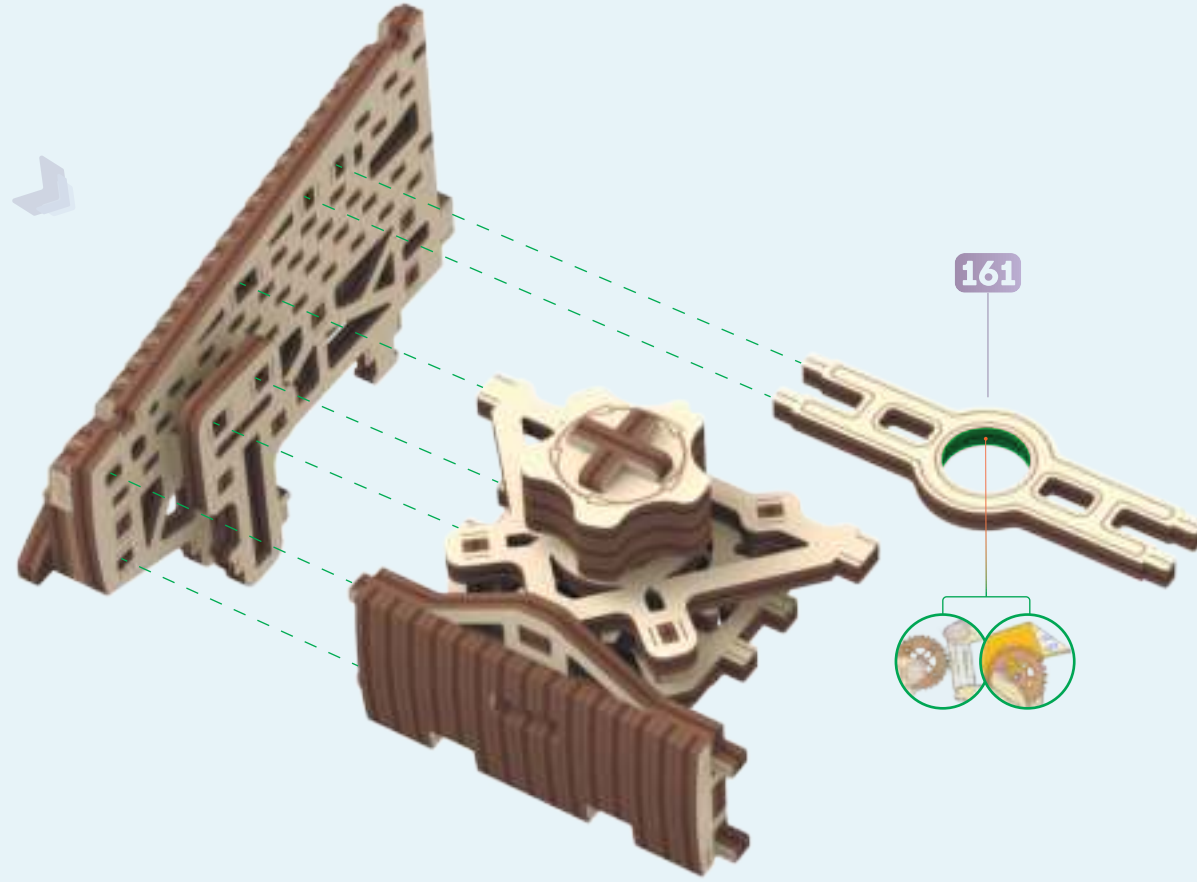
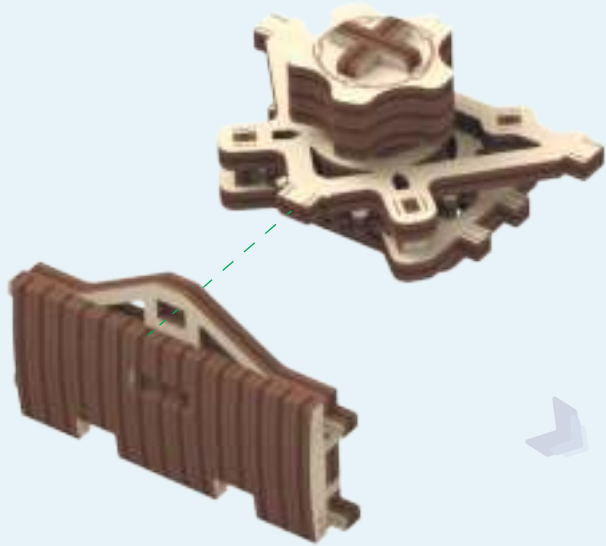

161

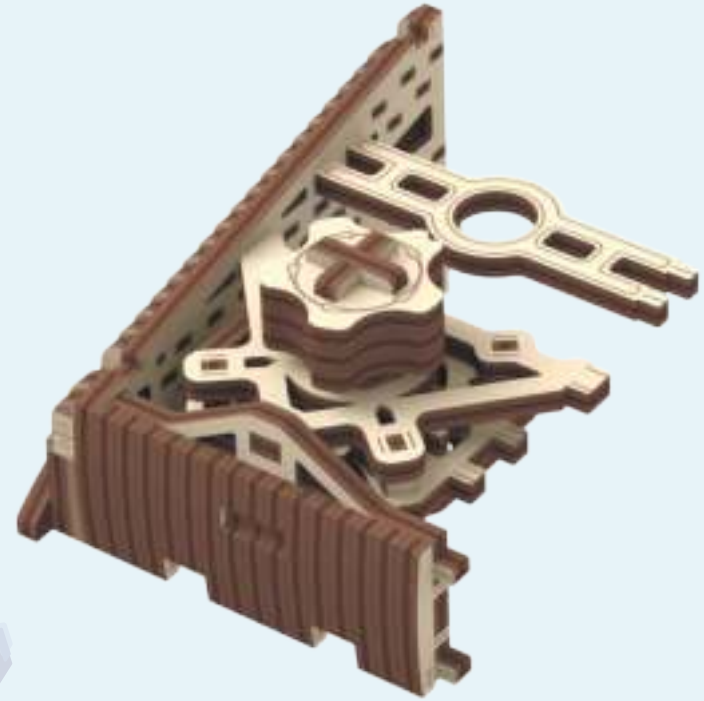

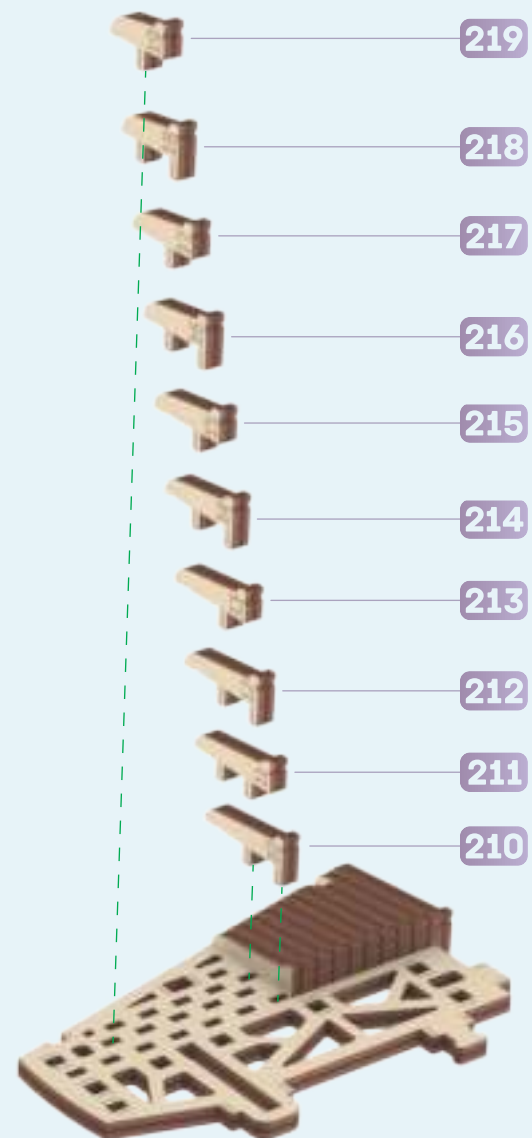
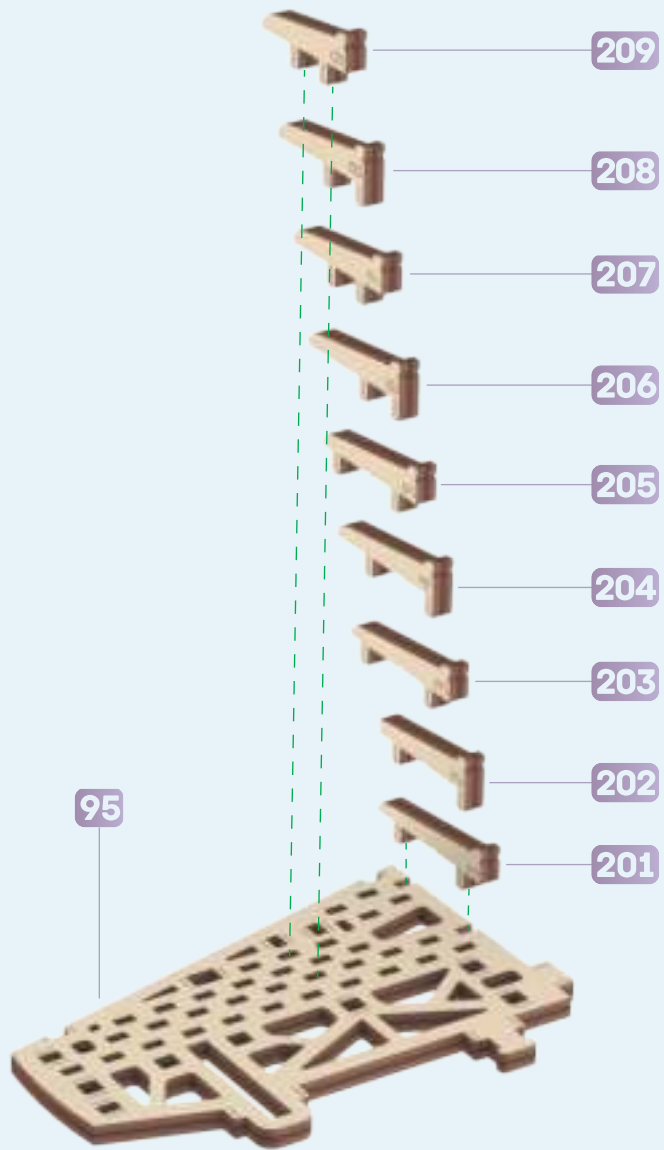

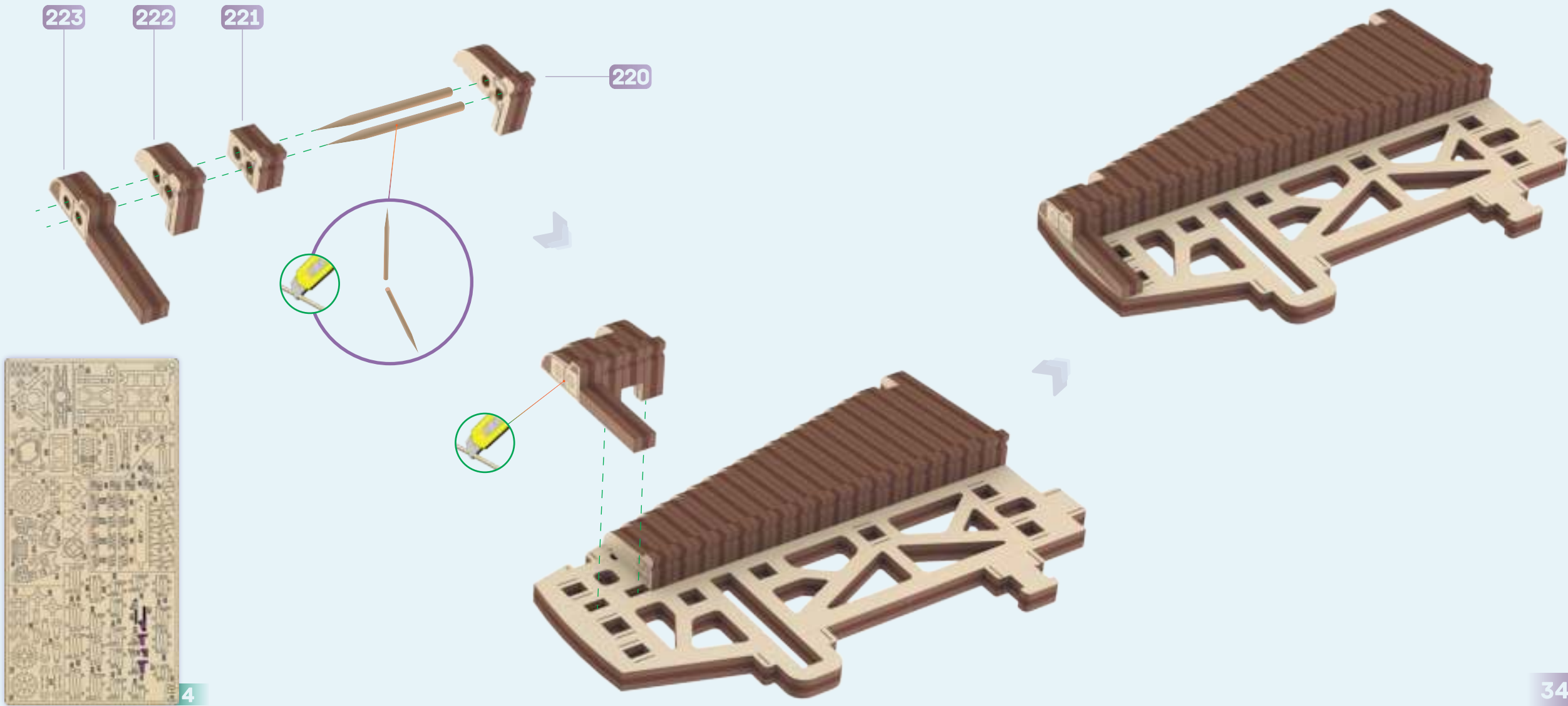



3

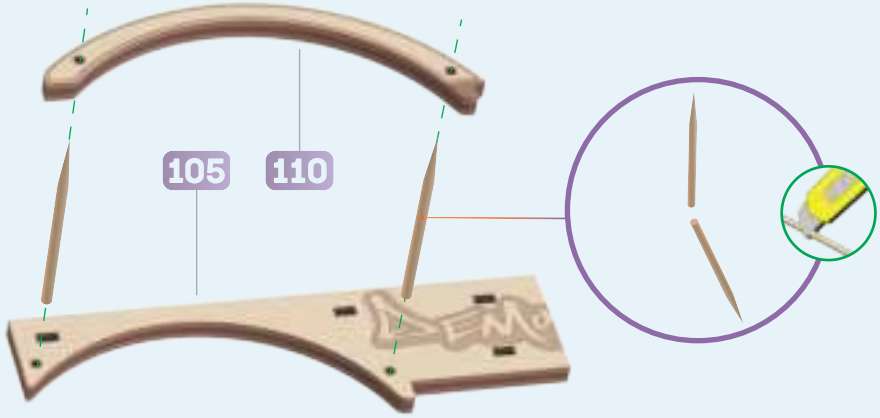

105

110

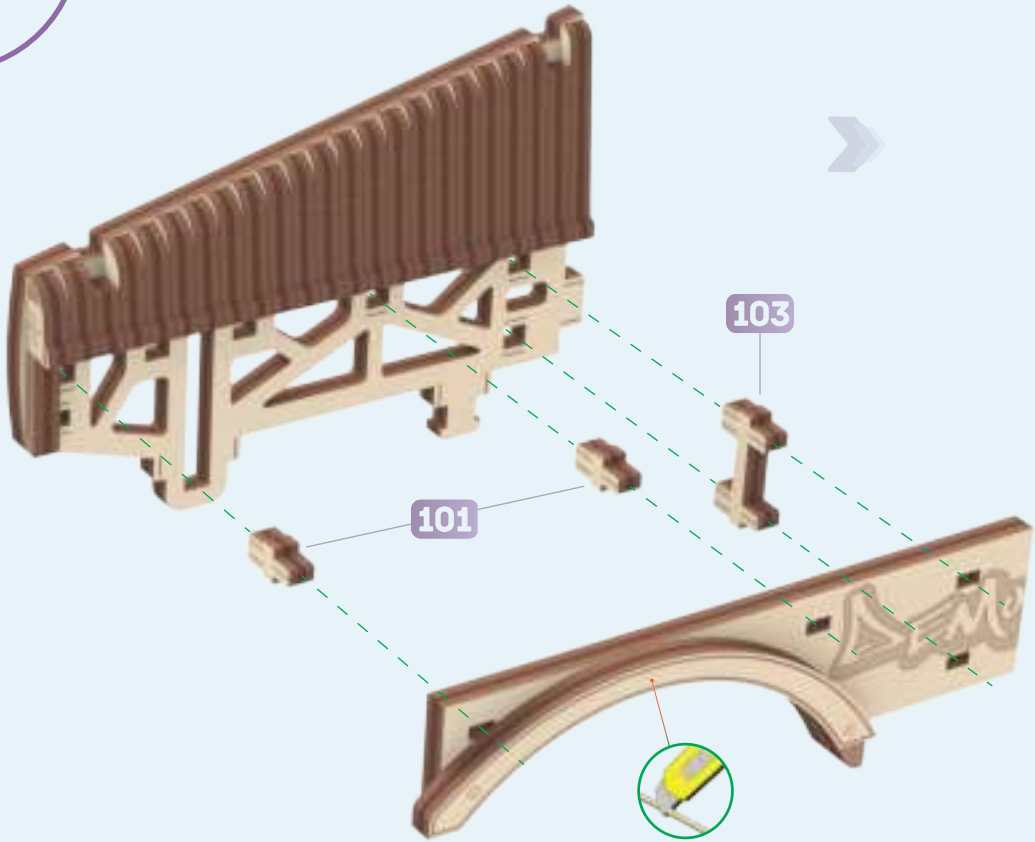

101

103



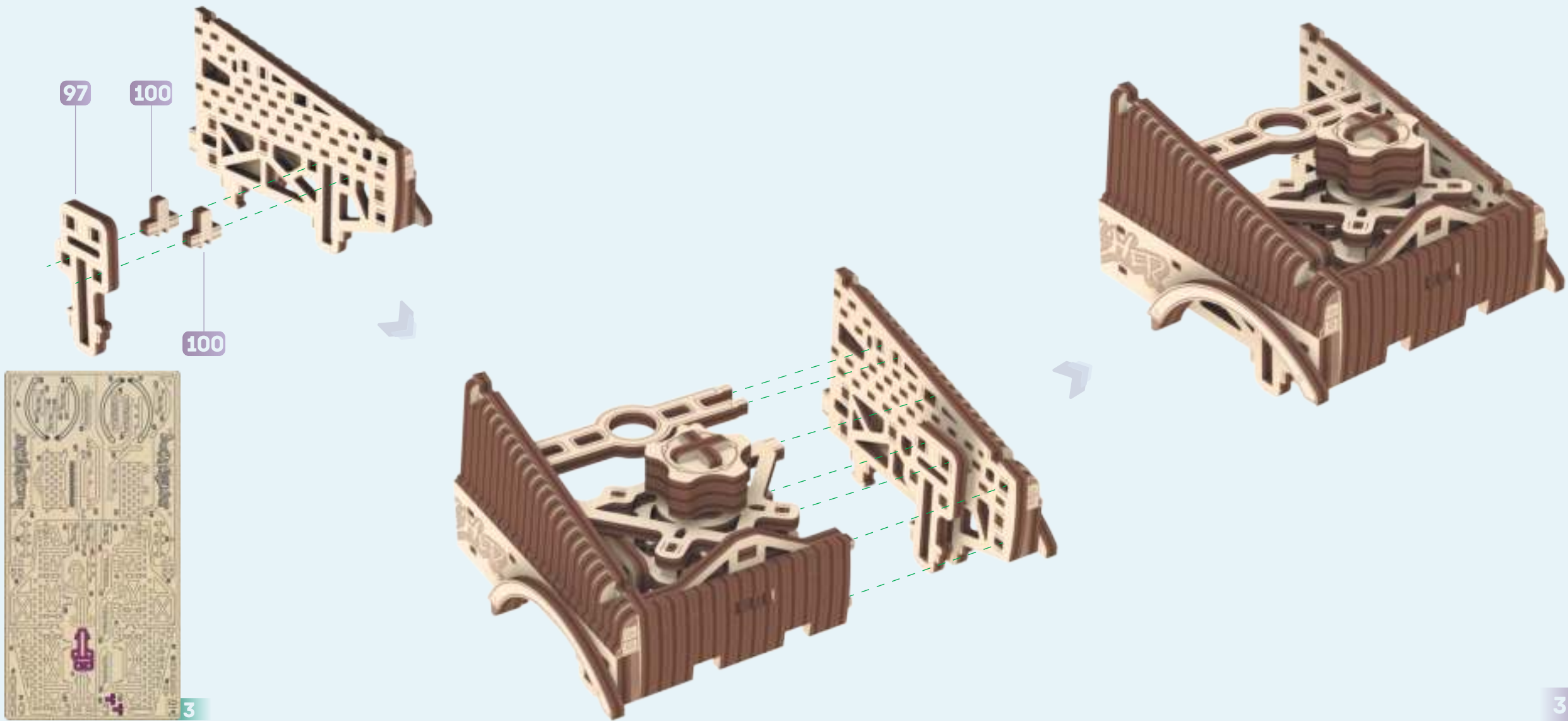

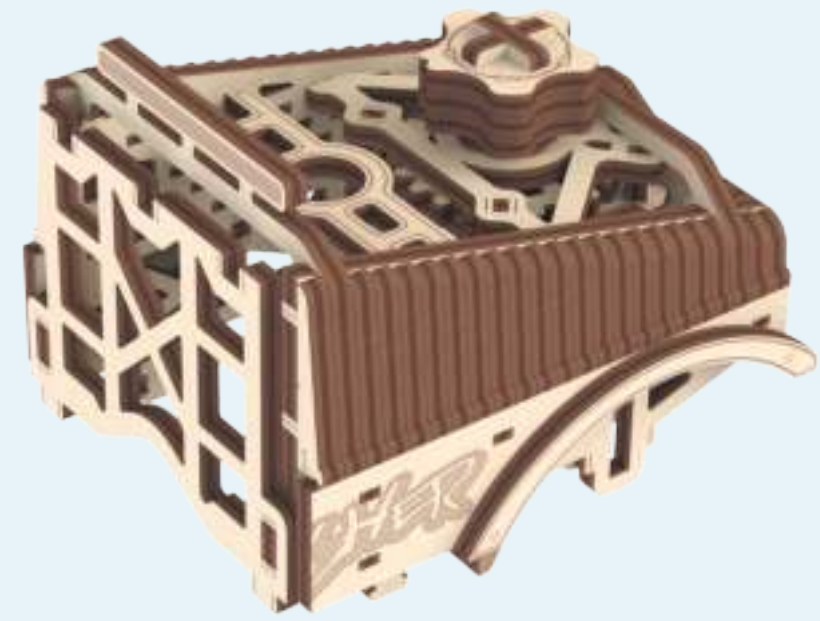
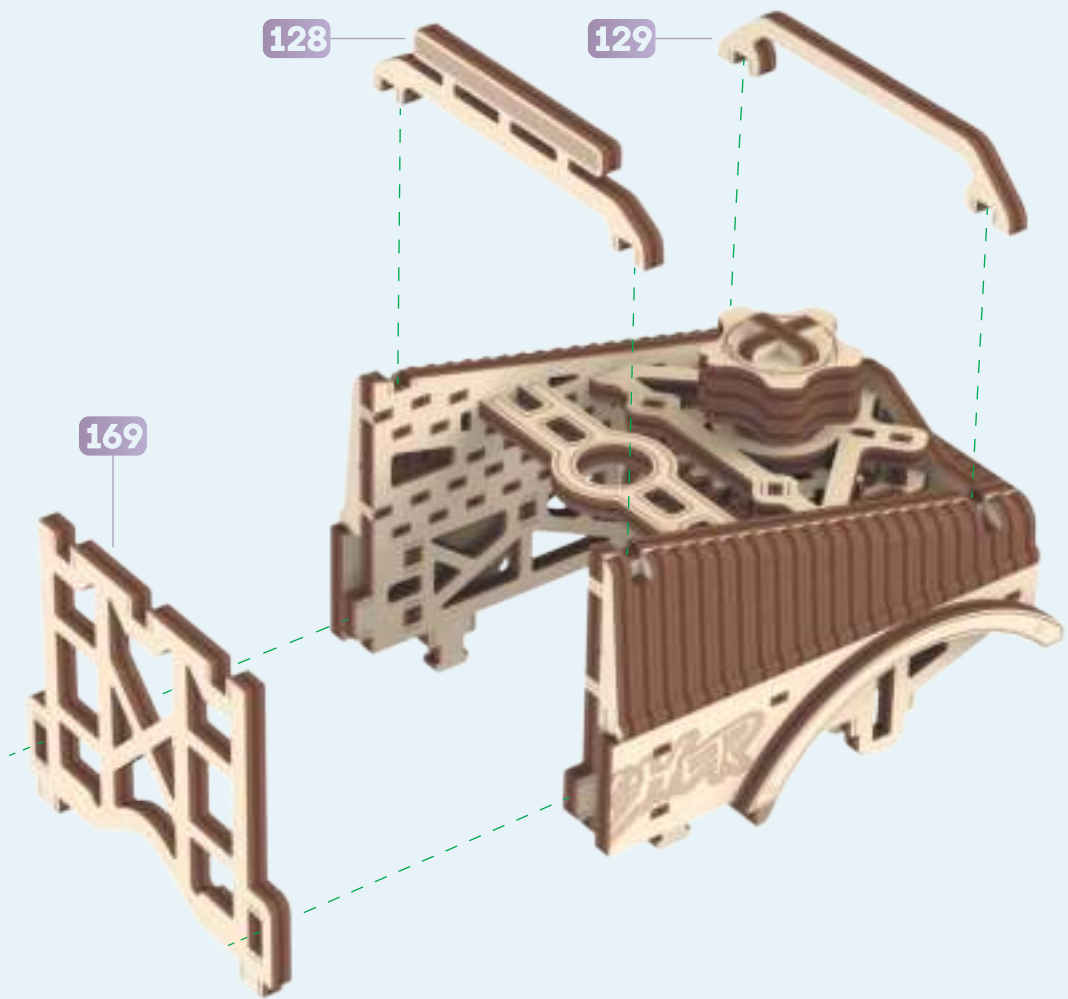



2

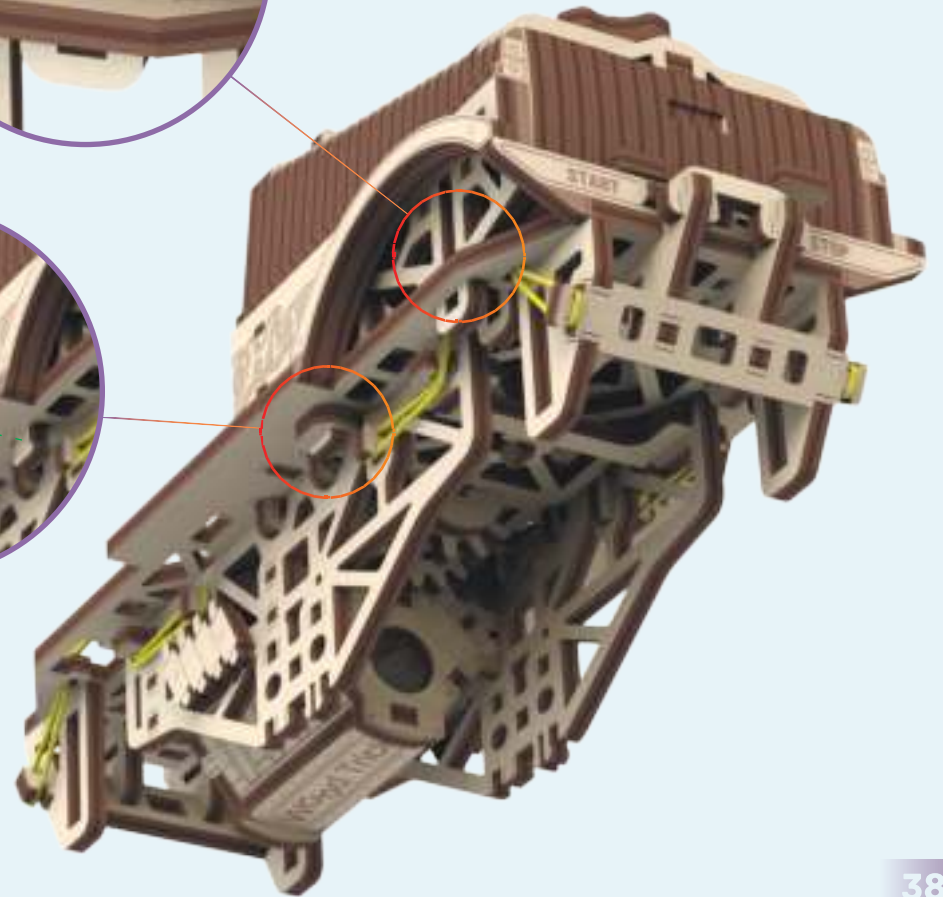
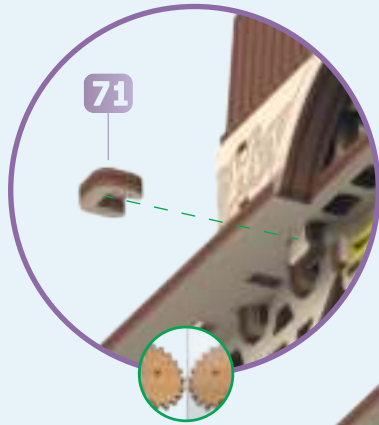
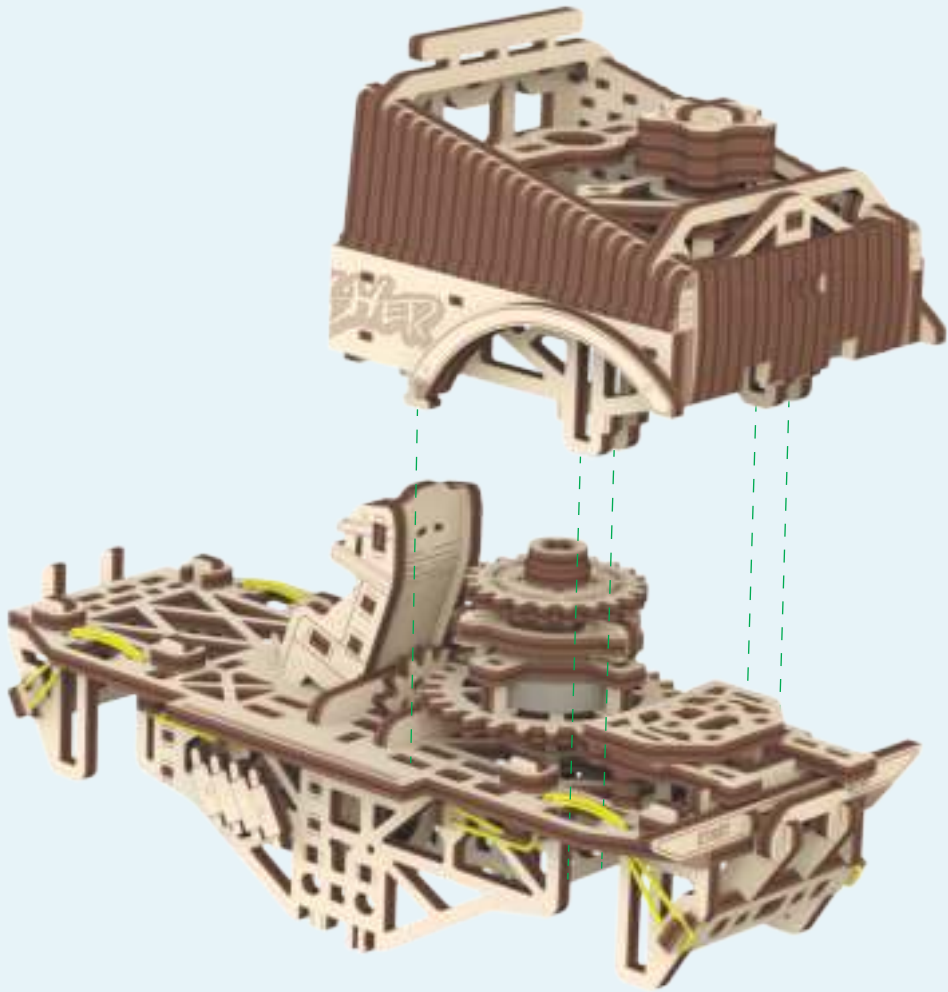

38

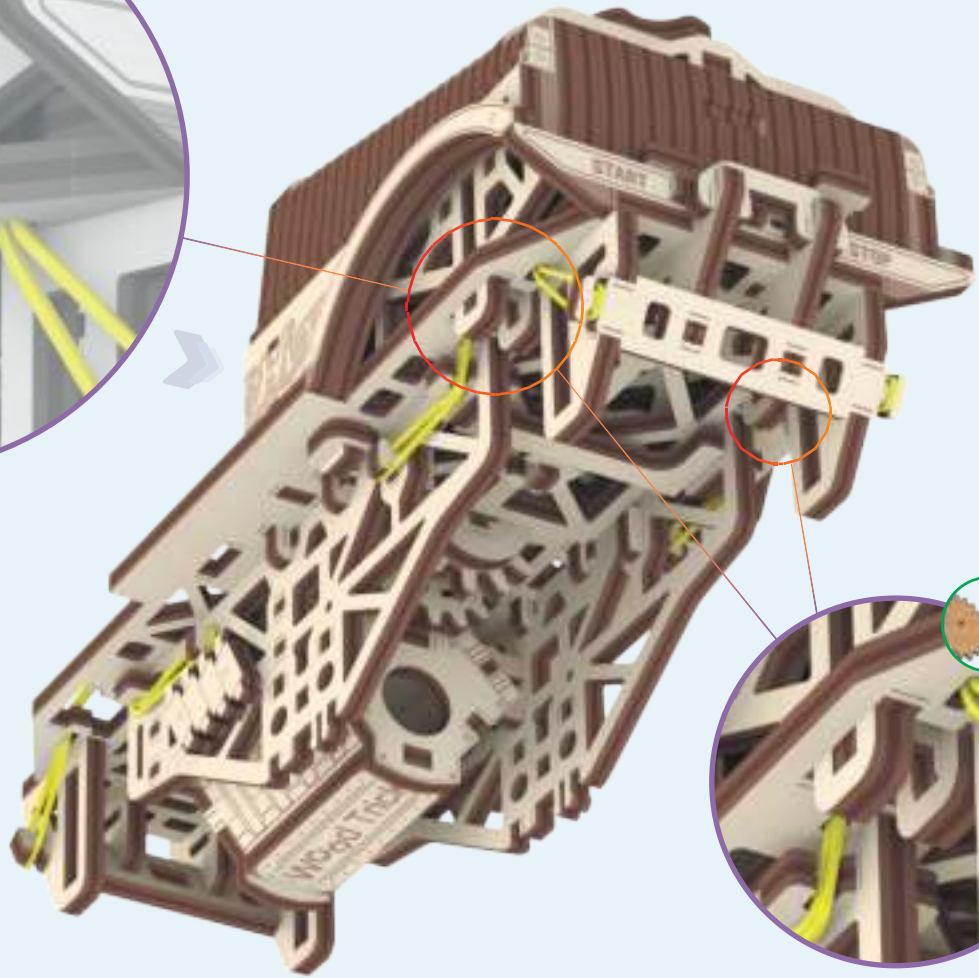
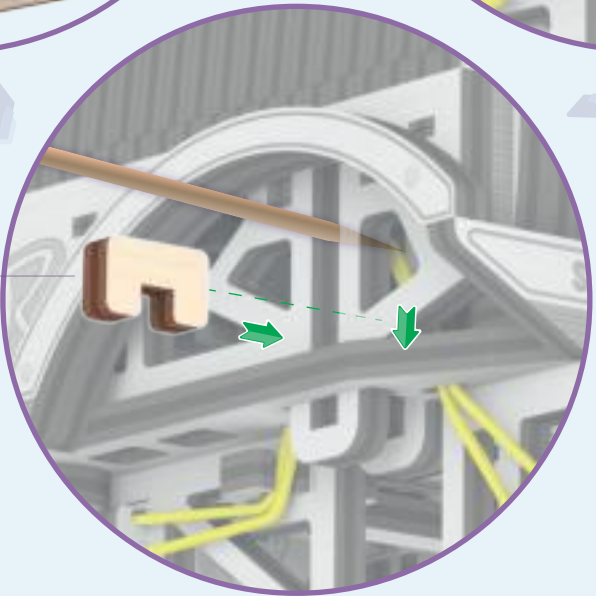
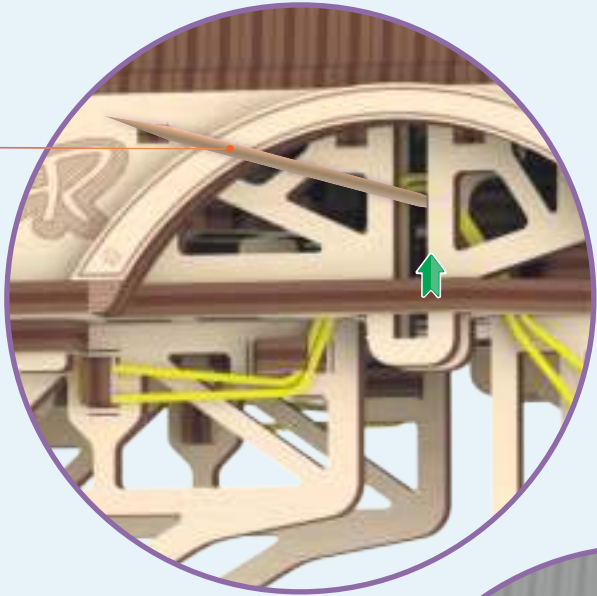
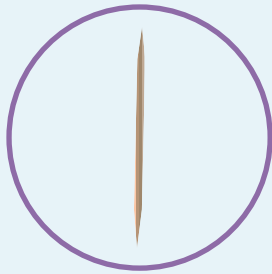

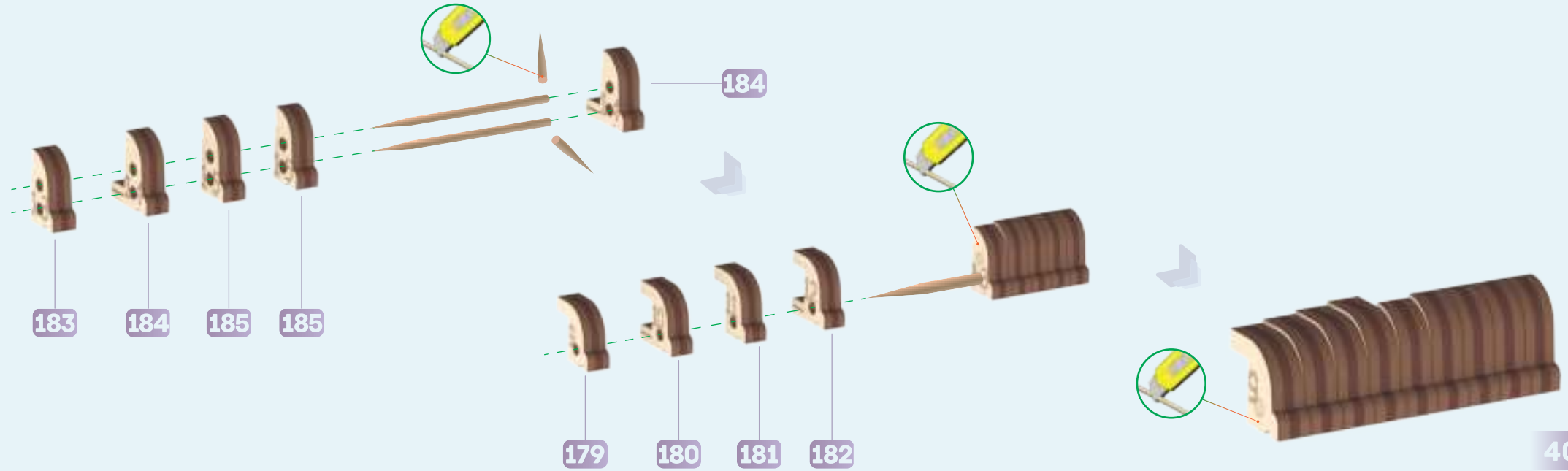
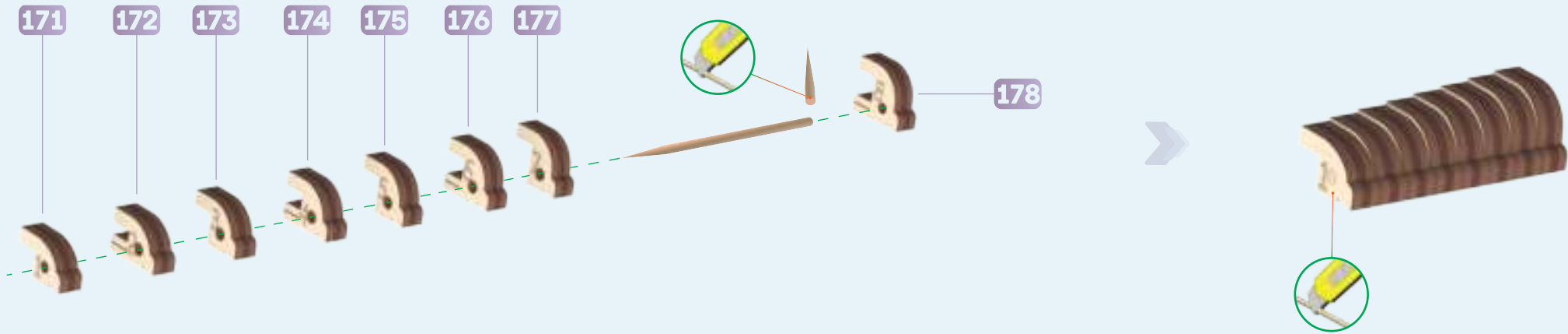

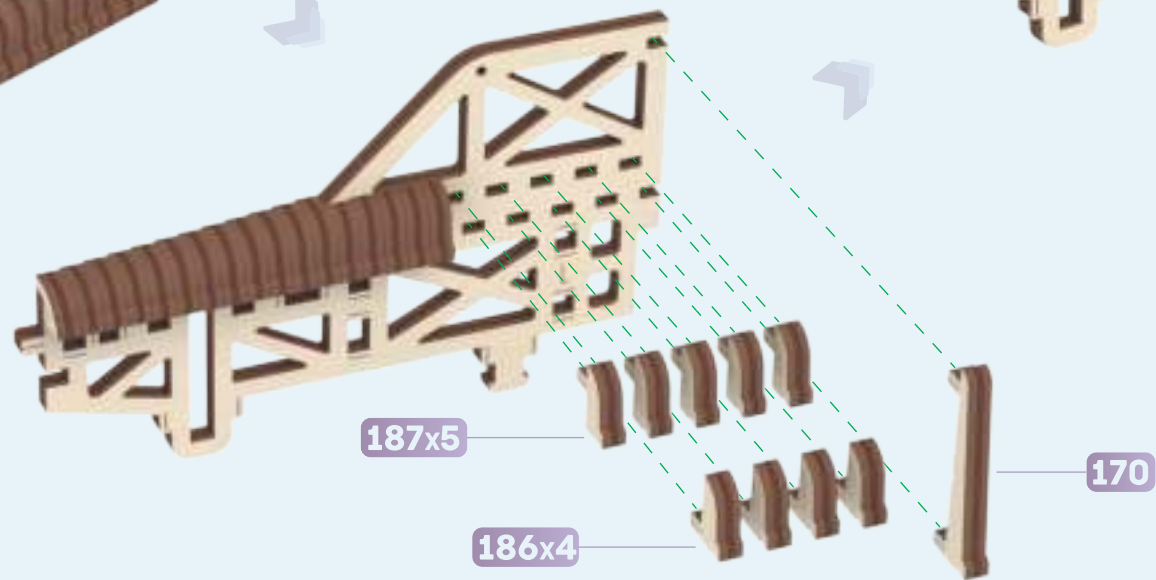
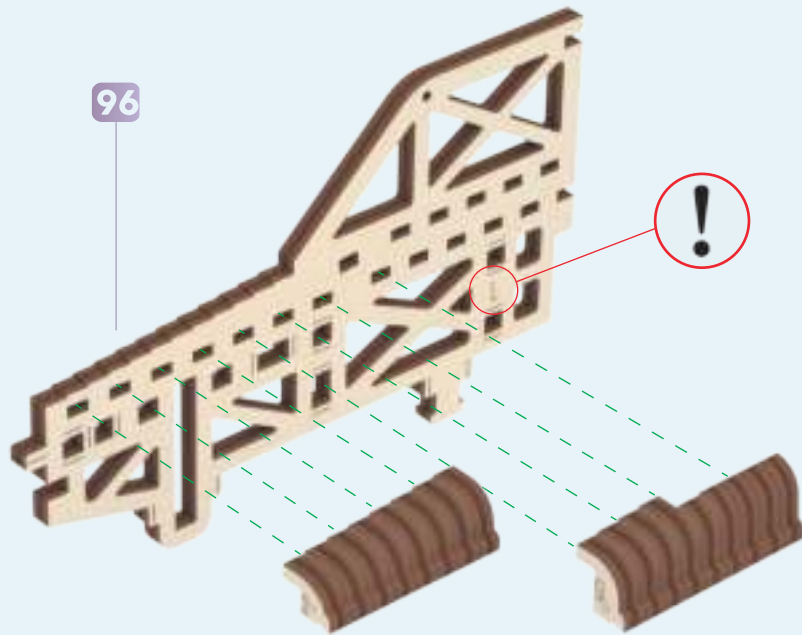
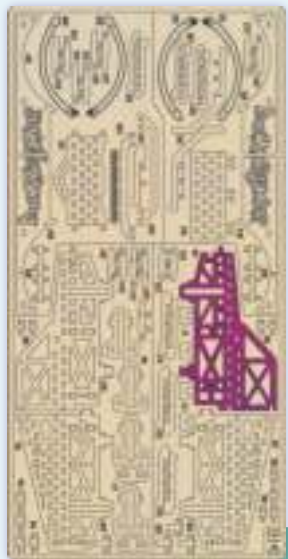

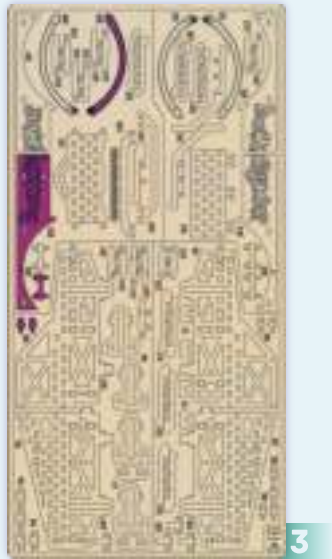

106

109

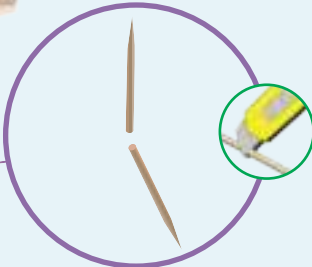

101

103



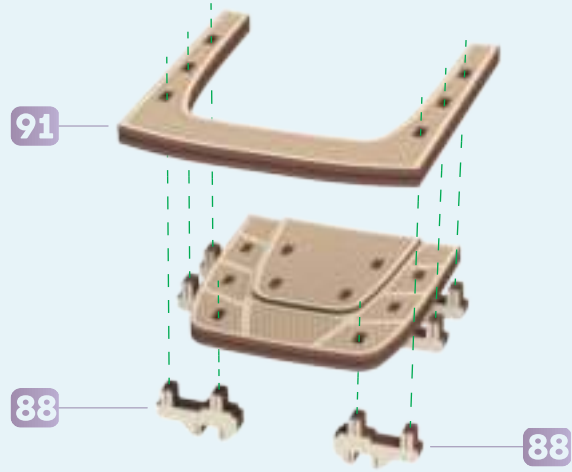
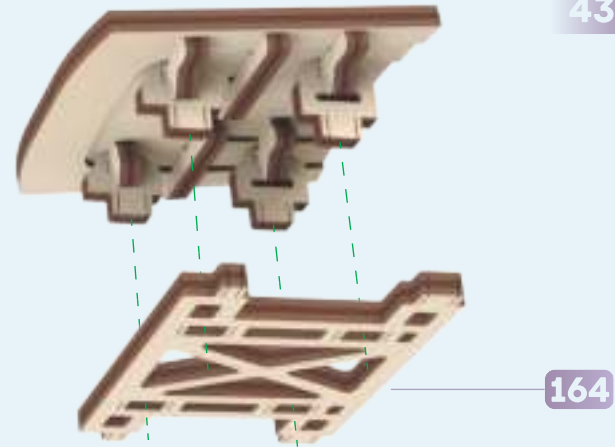
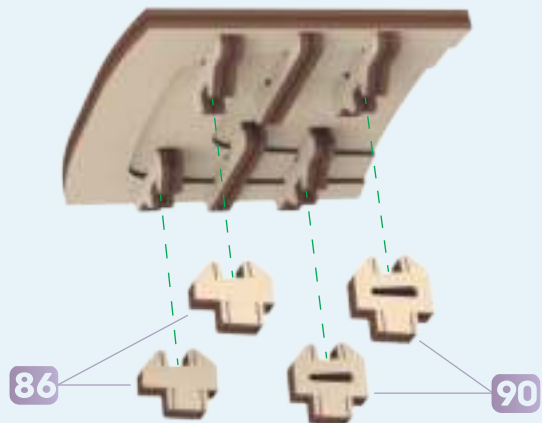
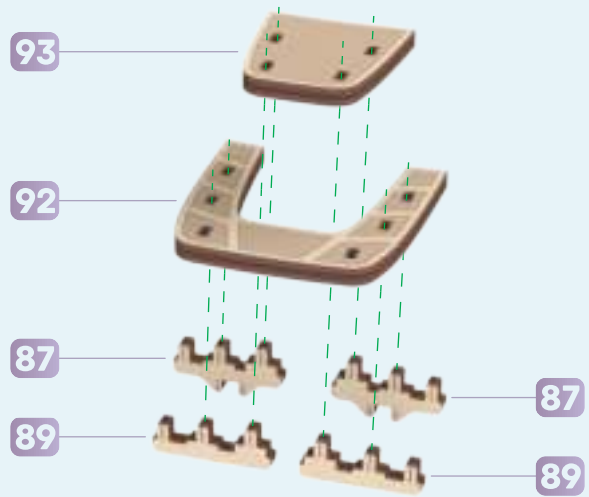

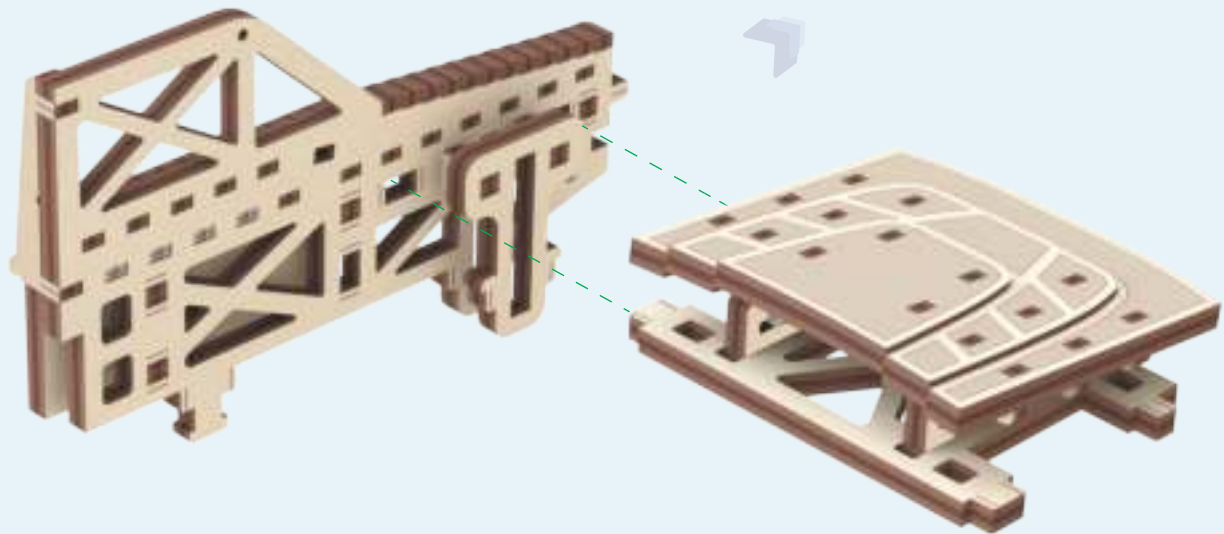
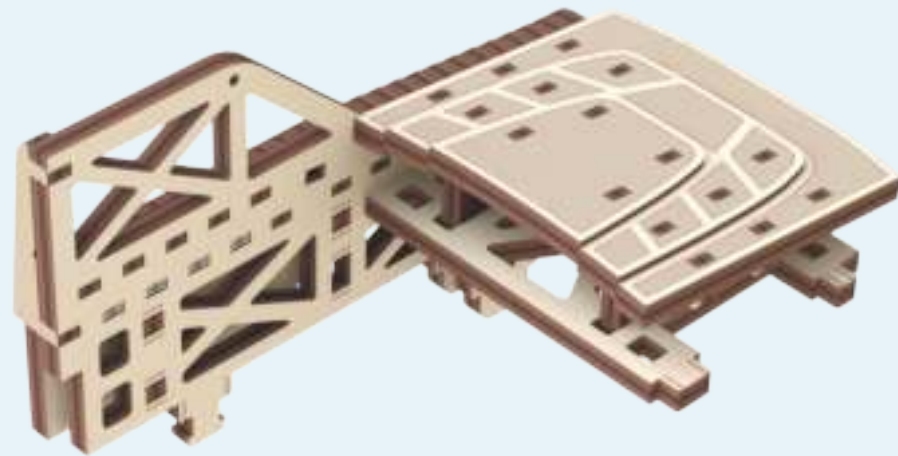
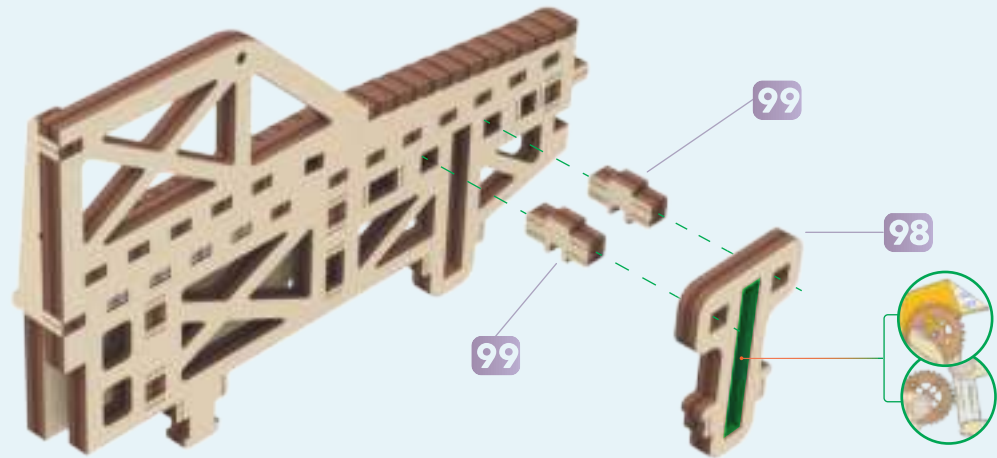



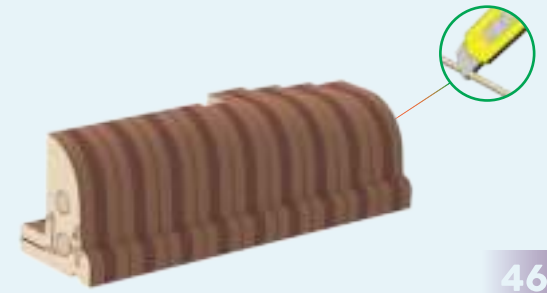
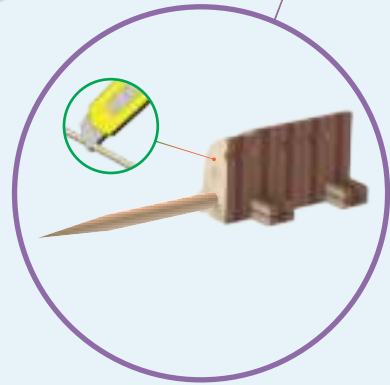
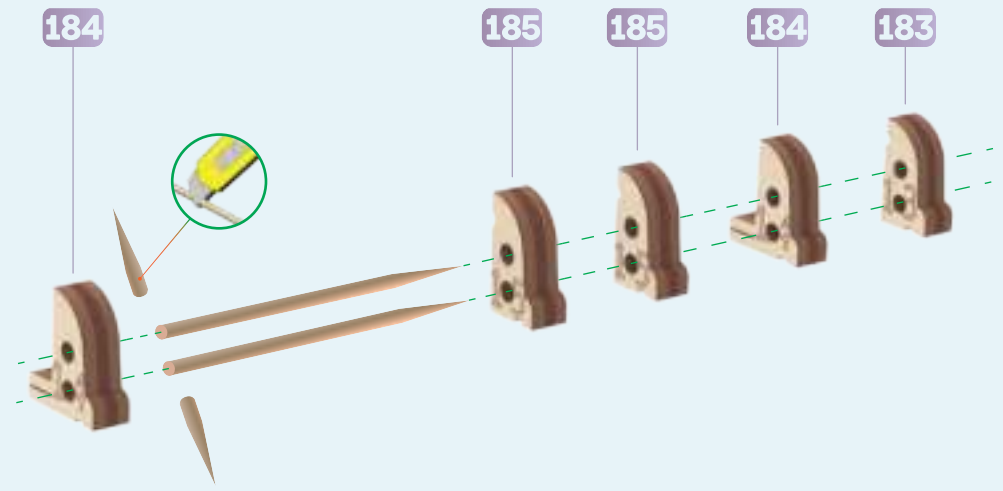
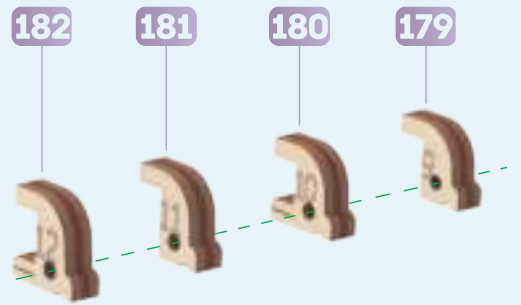
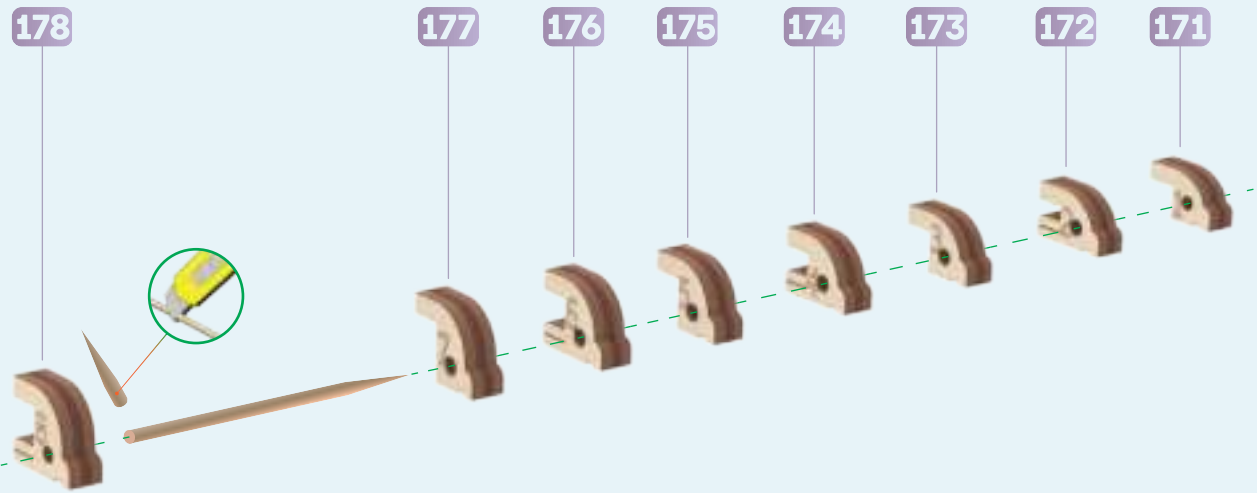

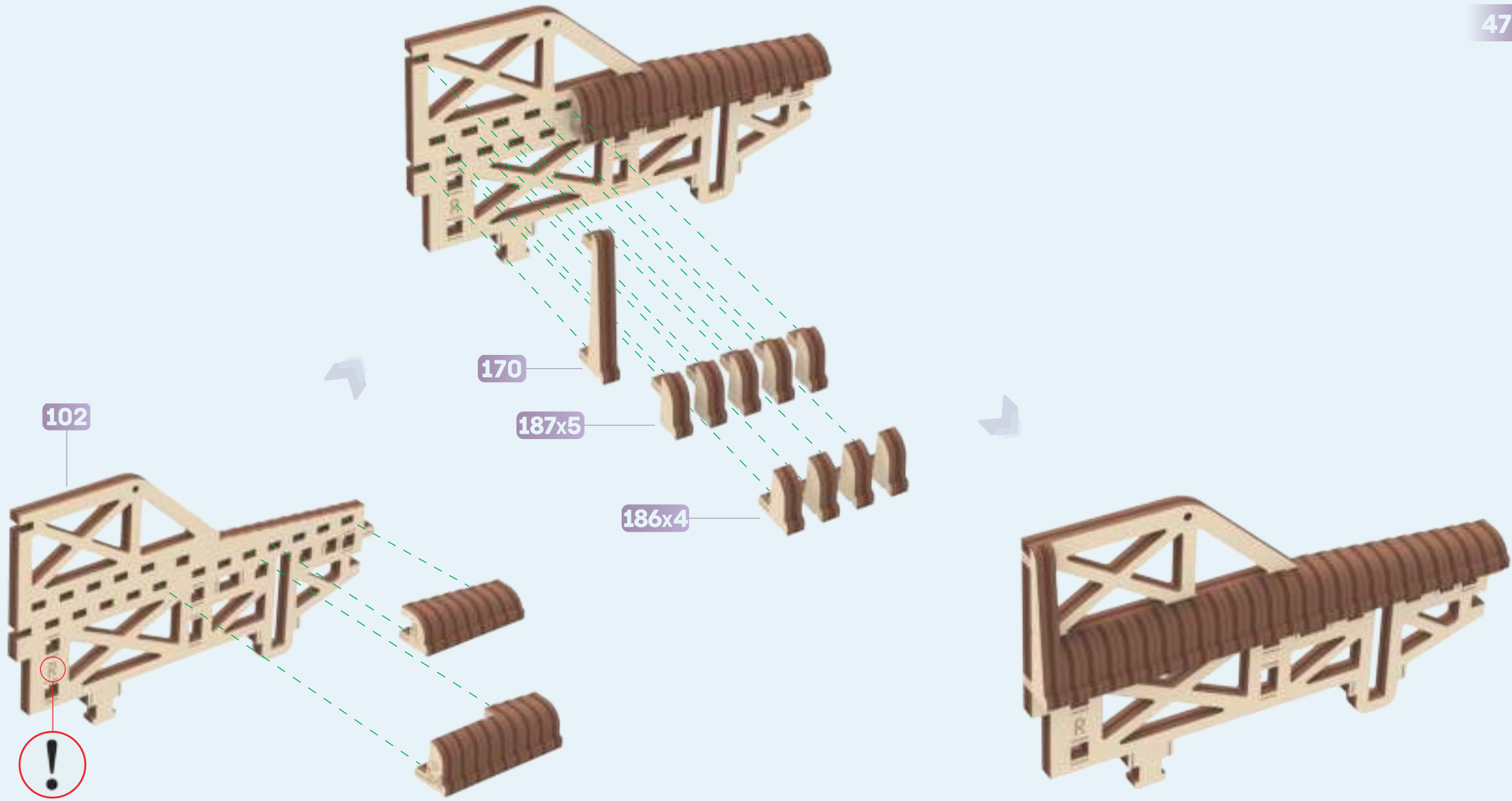

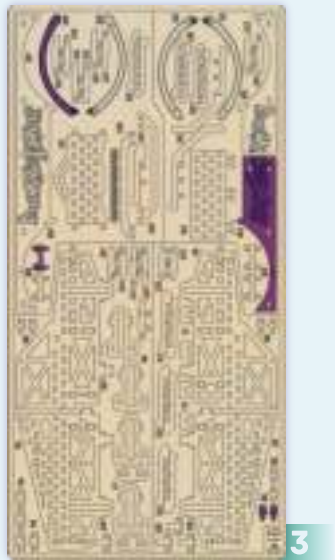

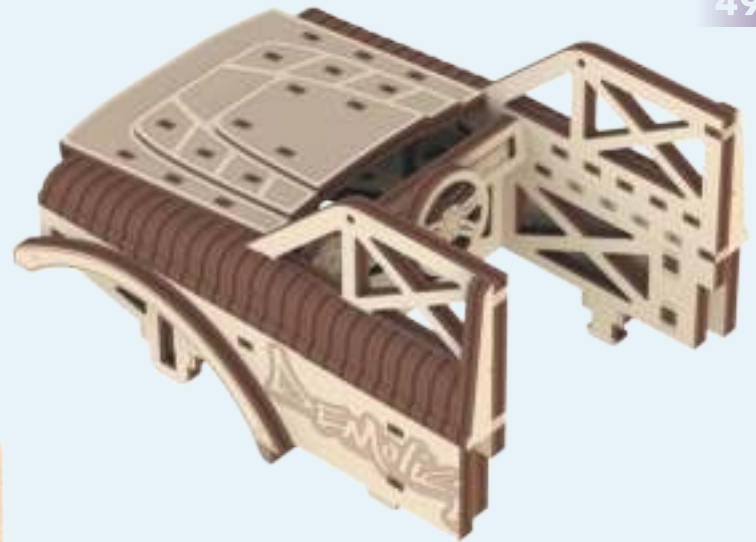
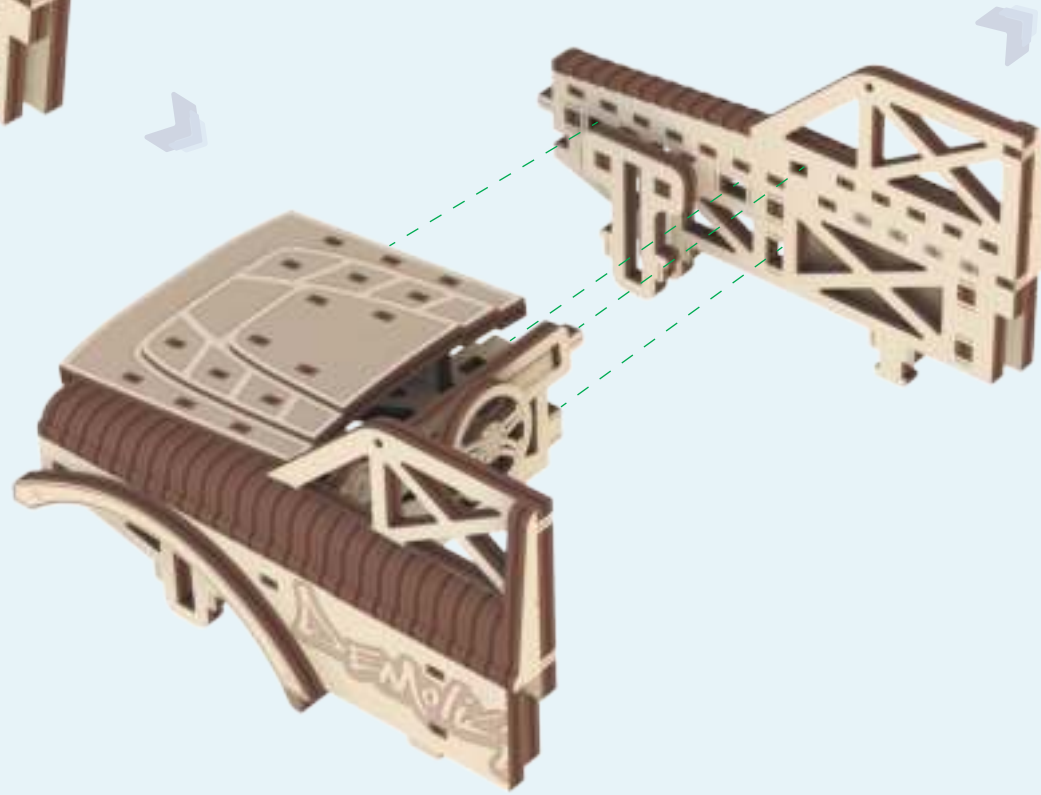
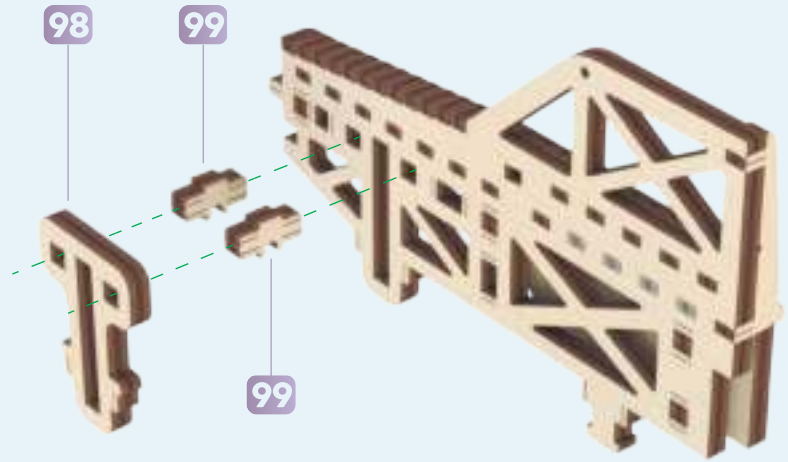

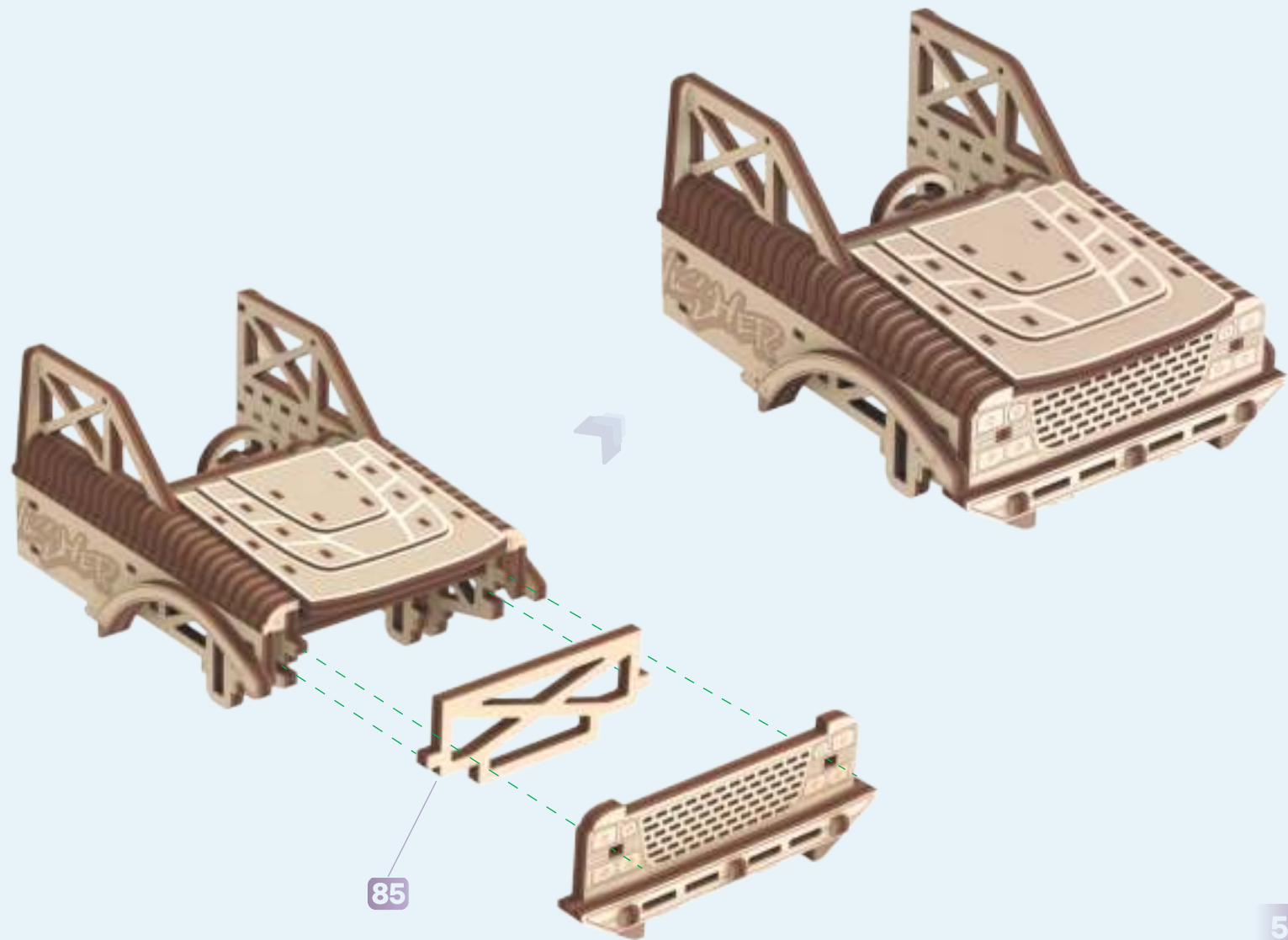
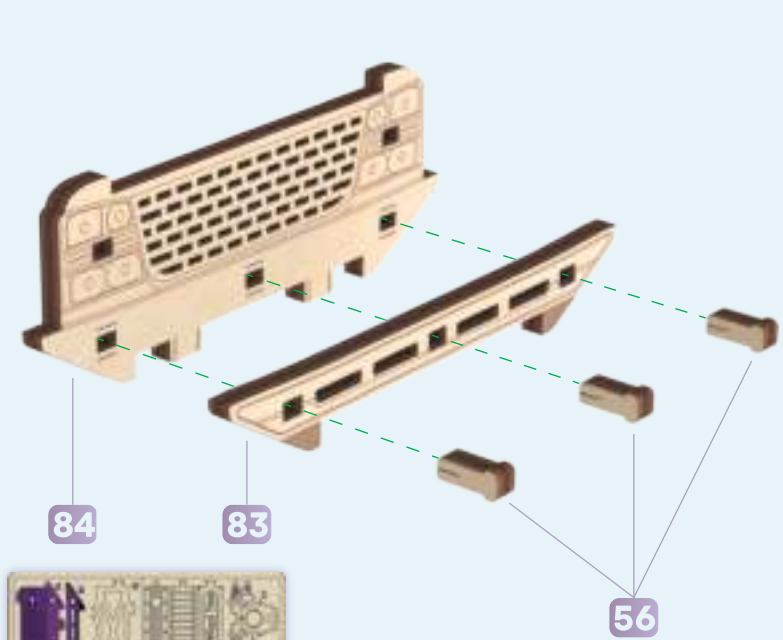

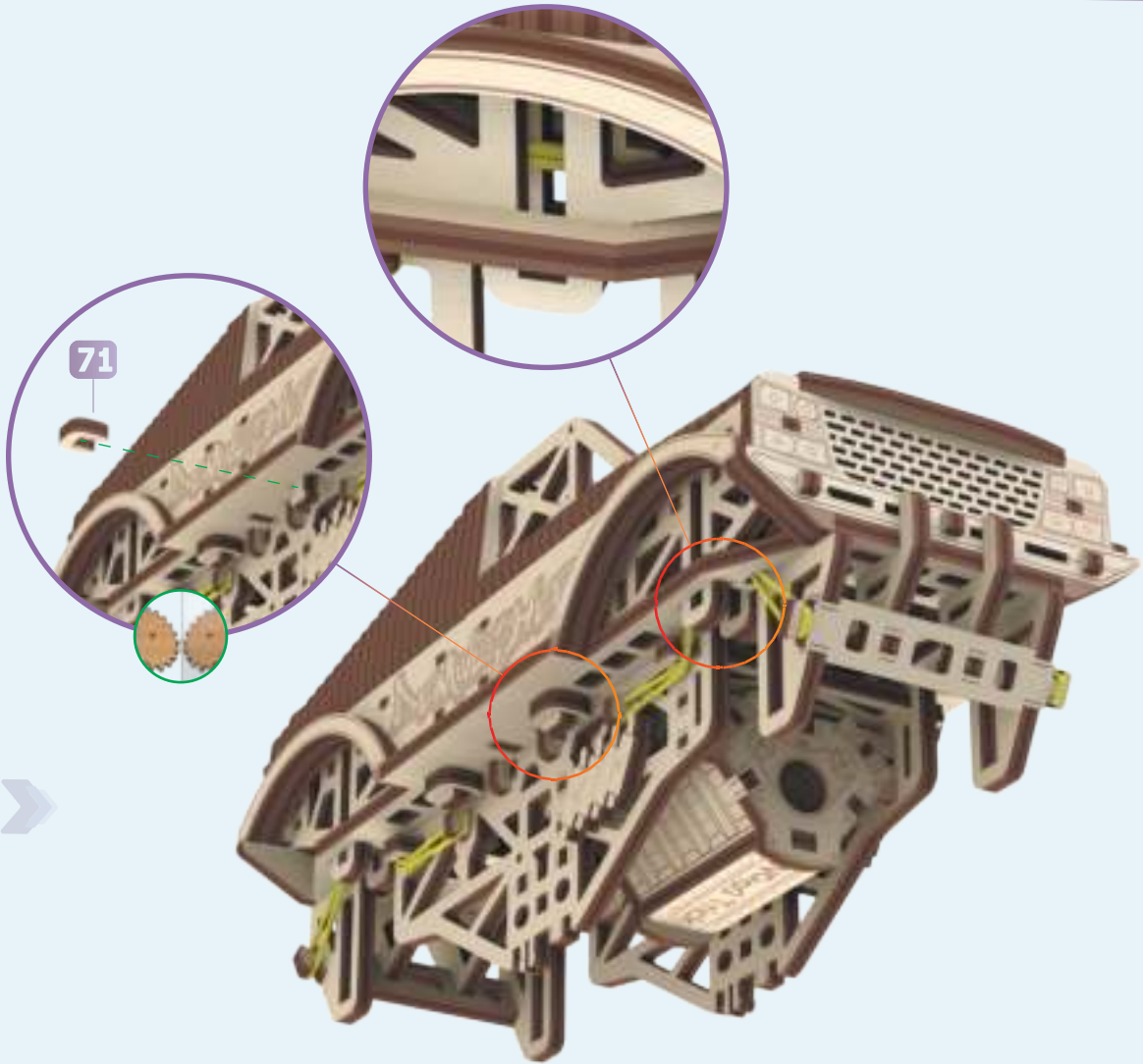
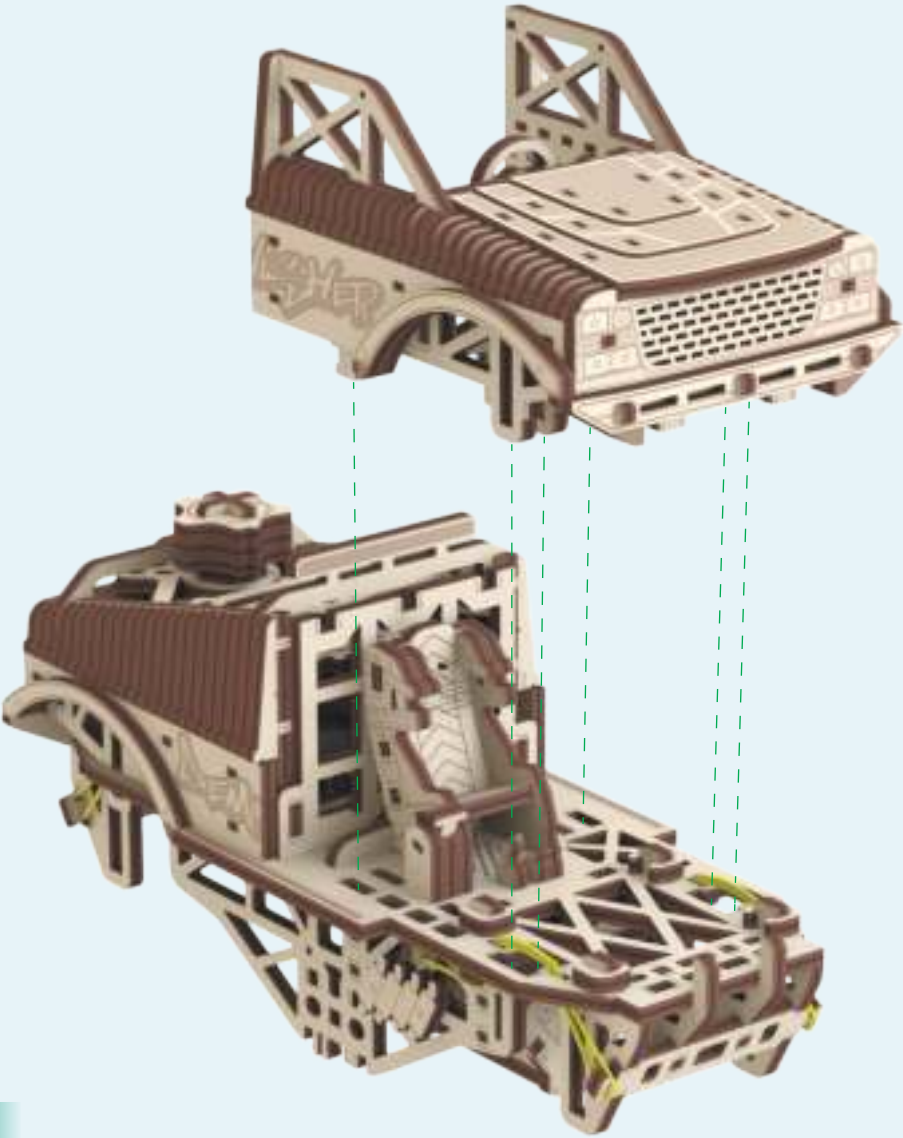

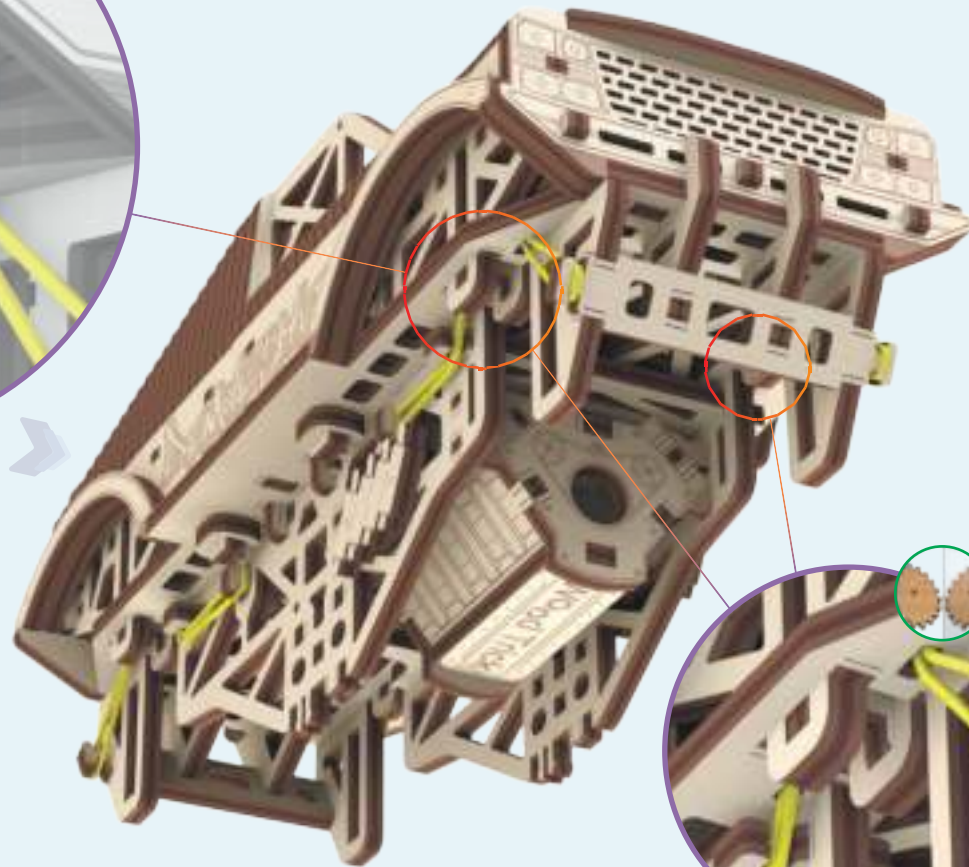
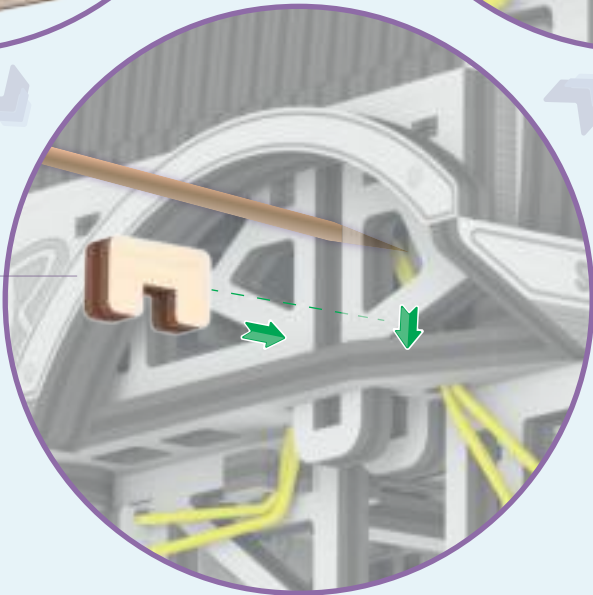
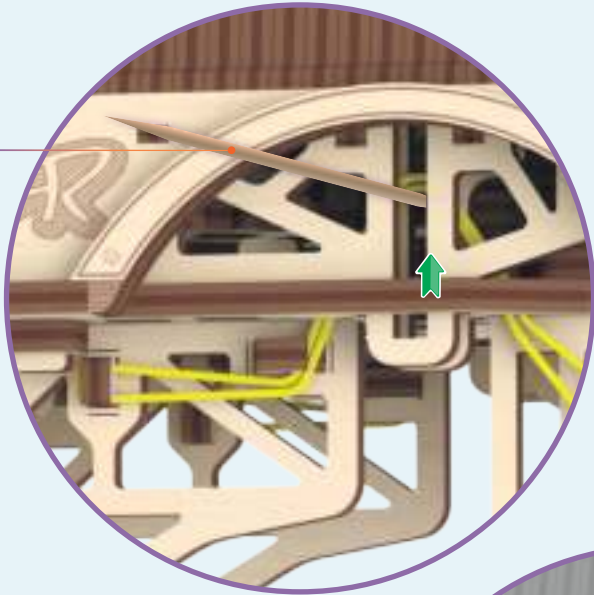
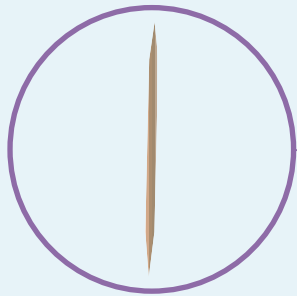

3

37



3

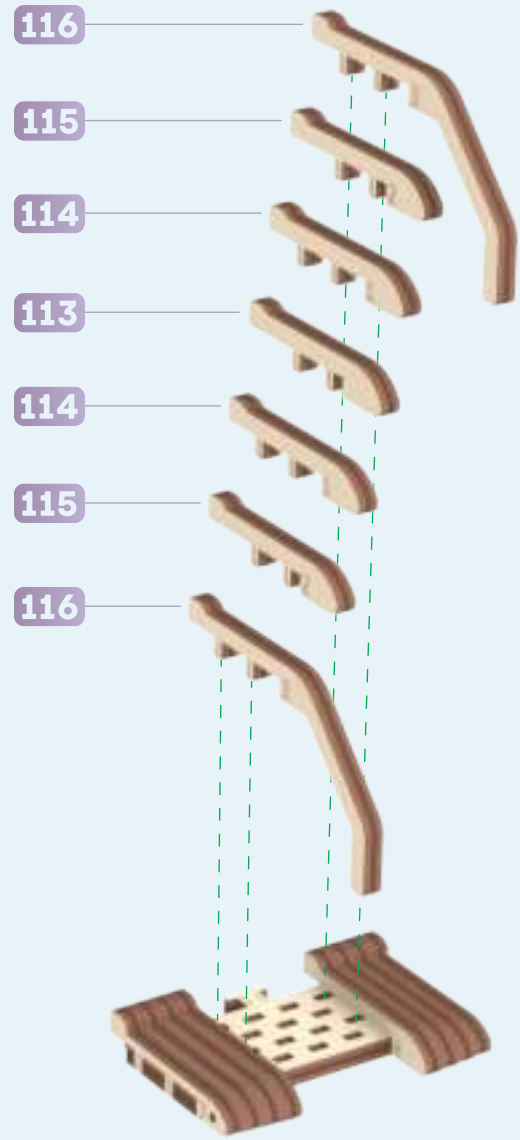

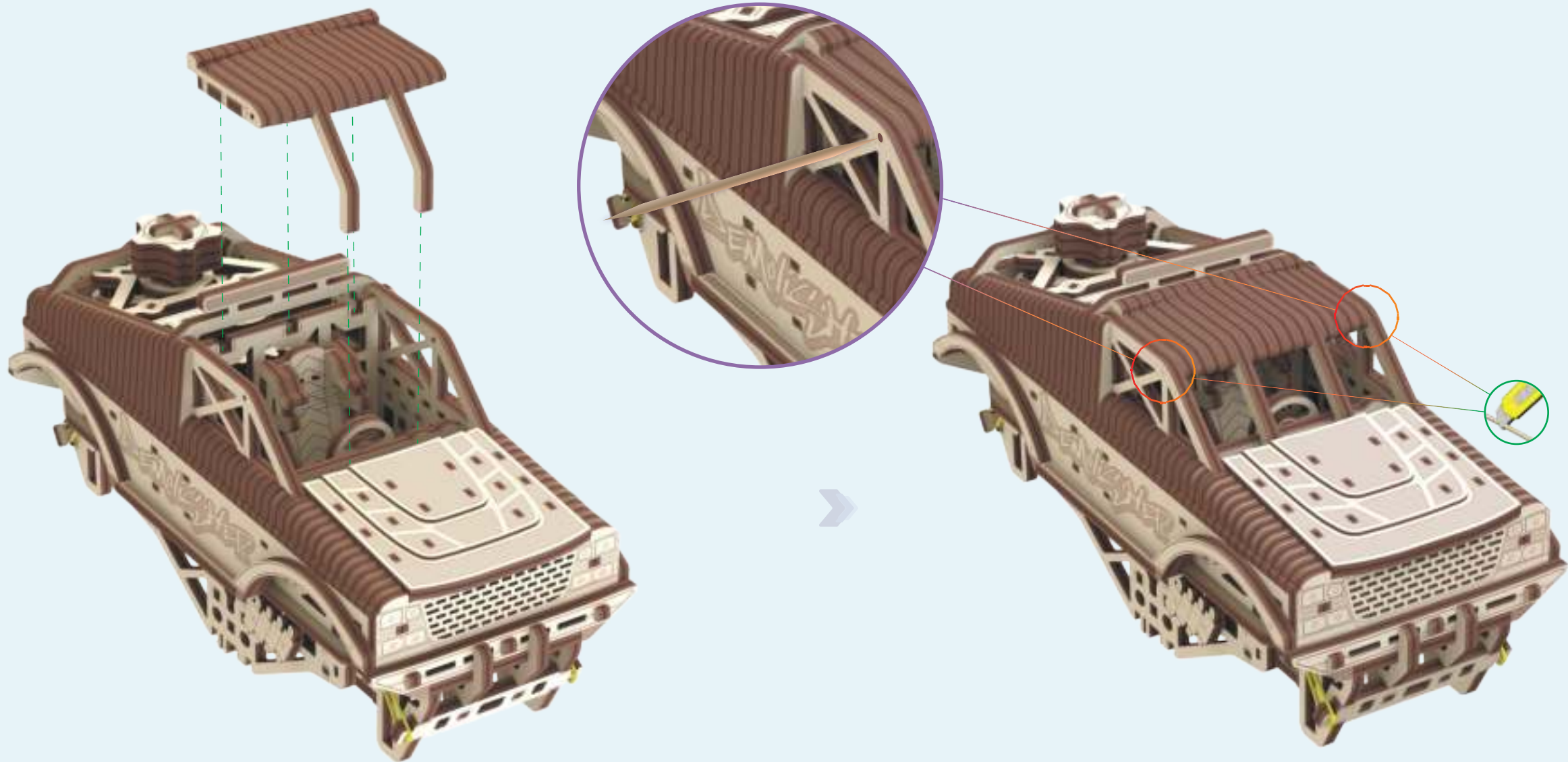

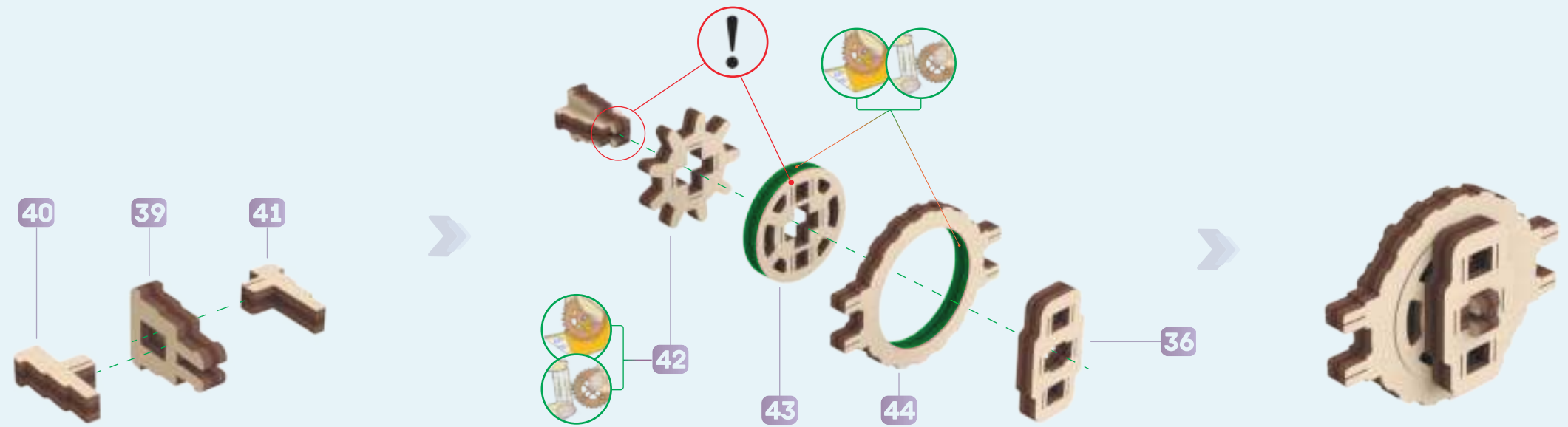
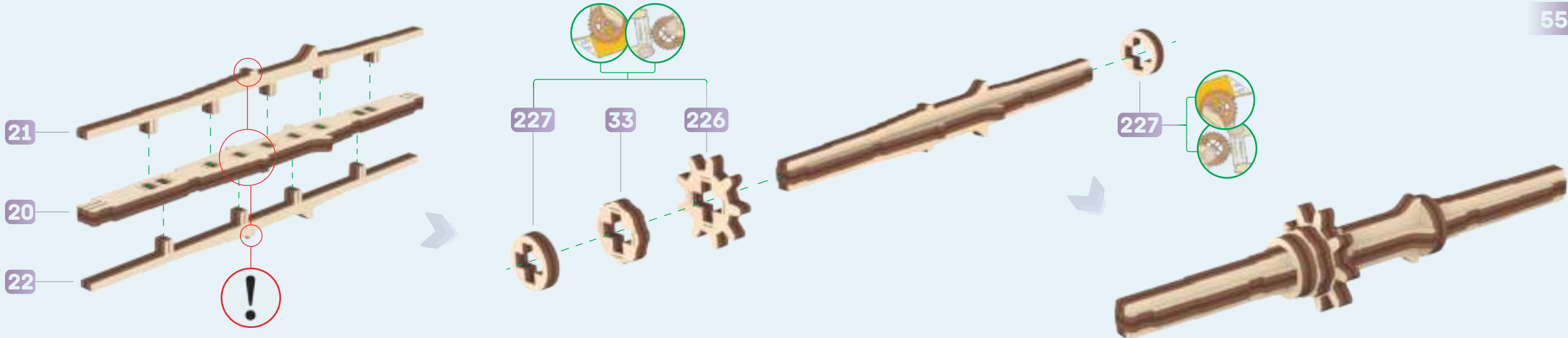



1

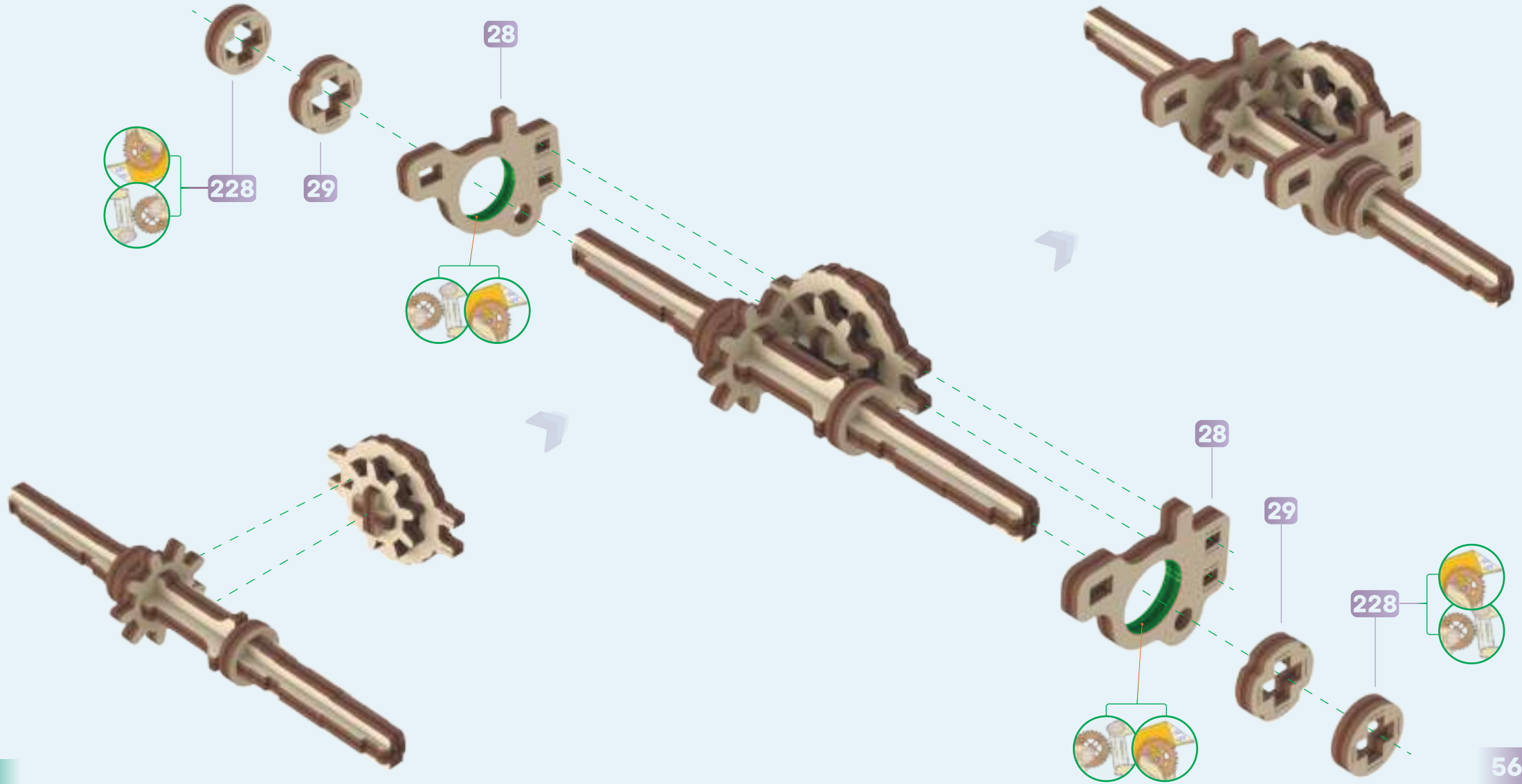



1



2

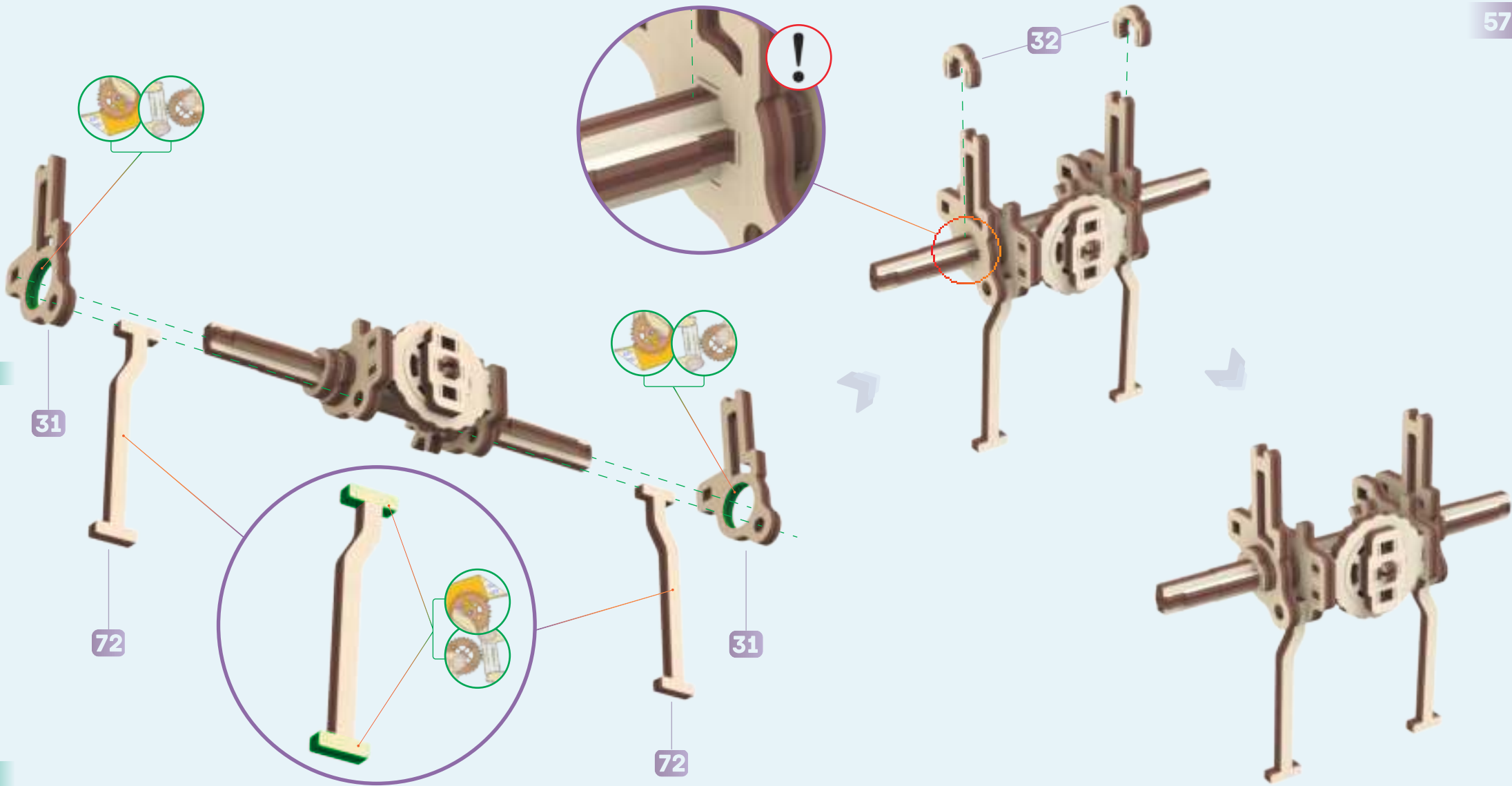

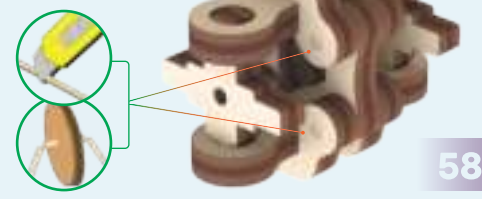
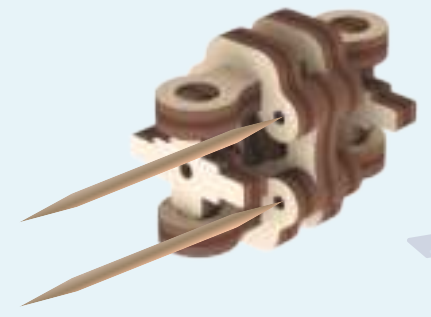
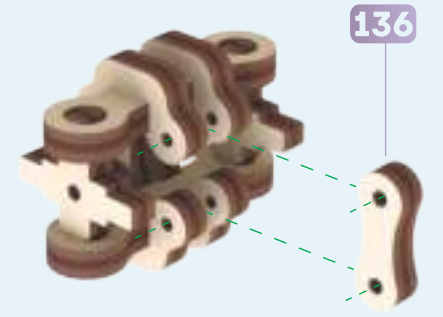
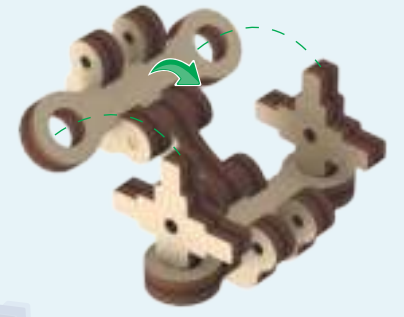
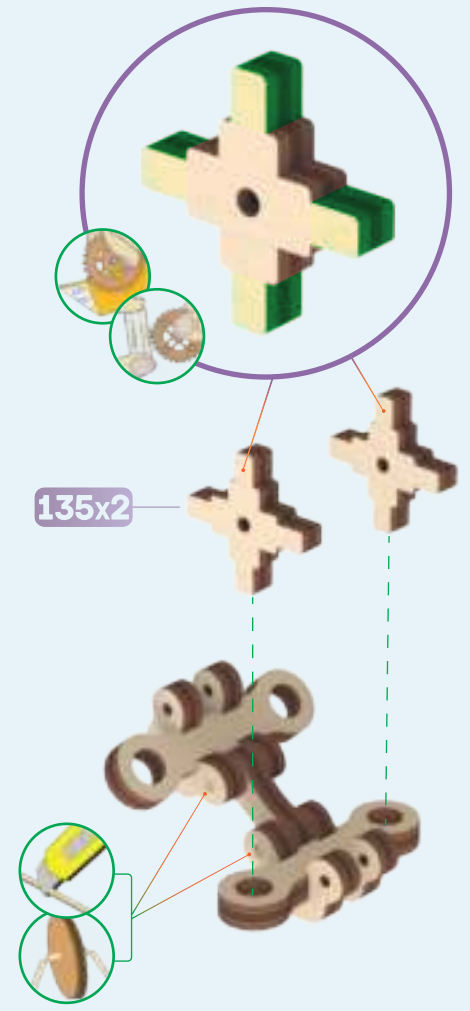
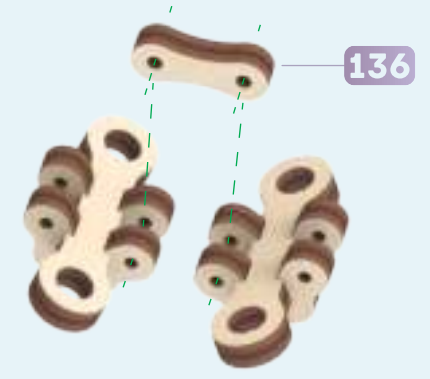
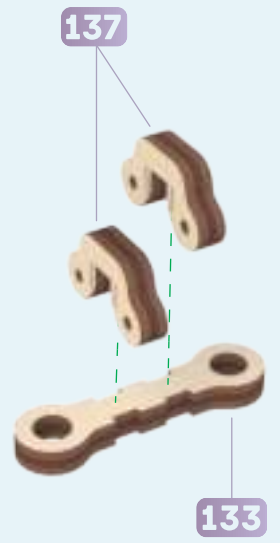

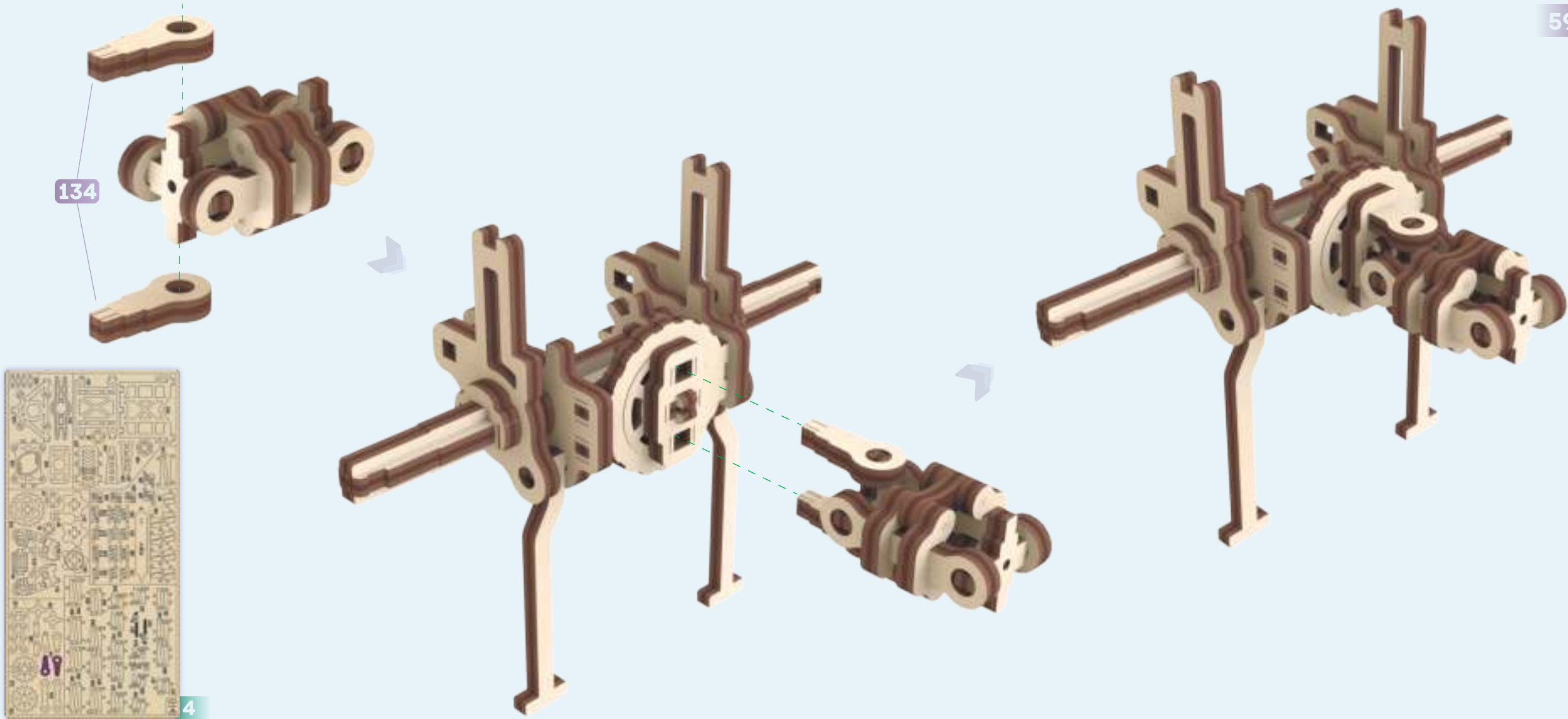

134



4



4



131

132

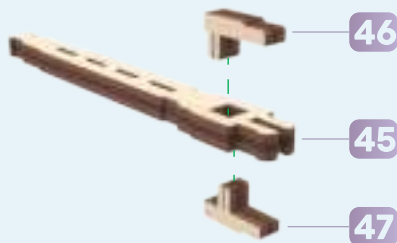
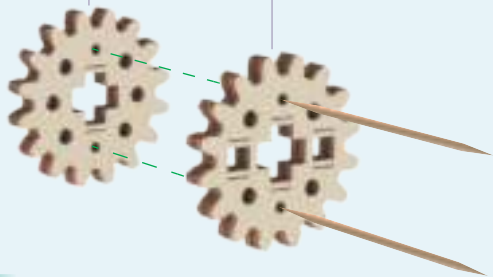

46

45

47

49

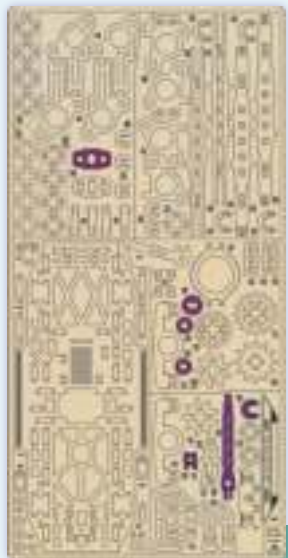
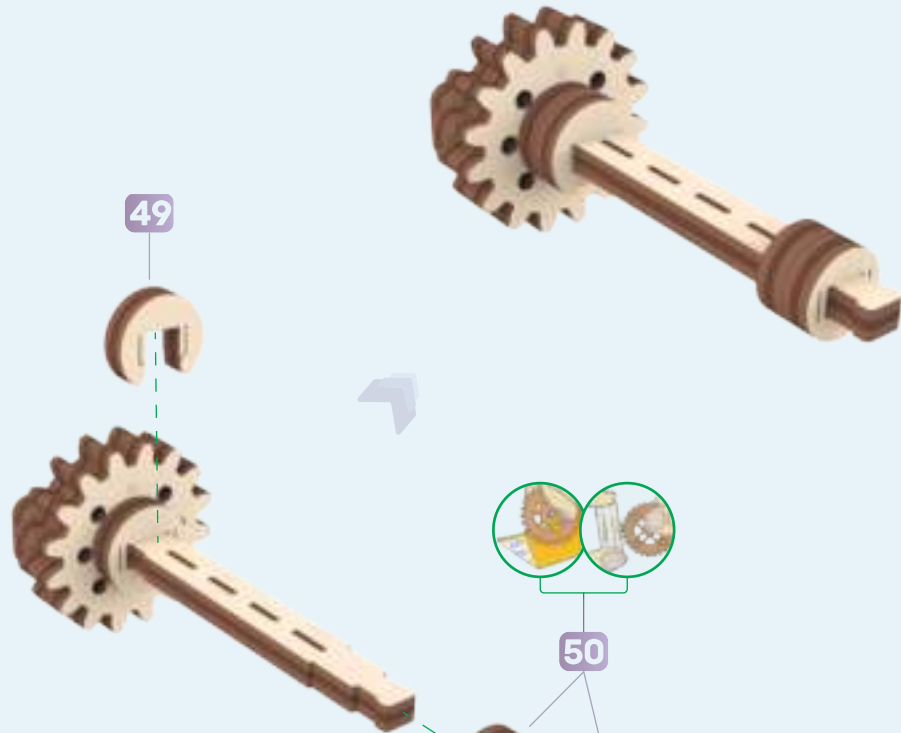

1



48



36



50

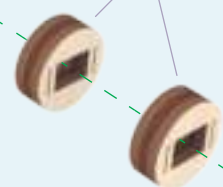



4

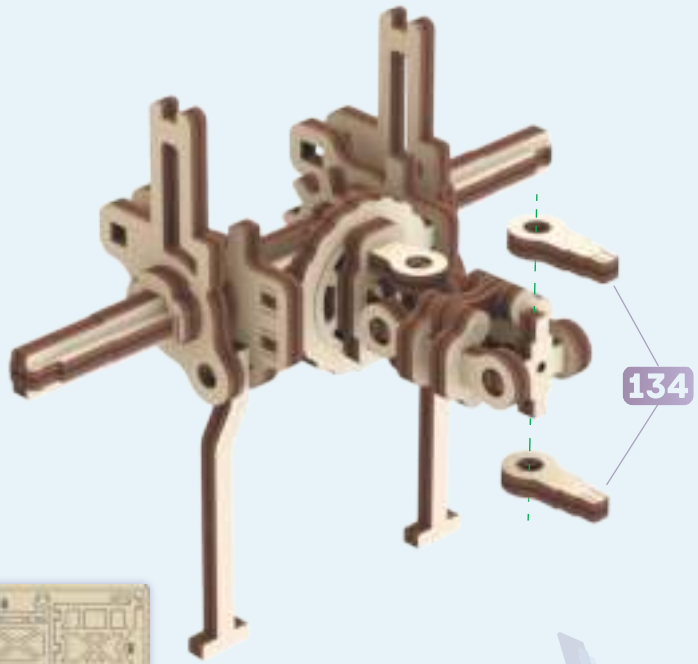

134

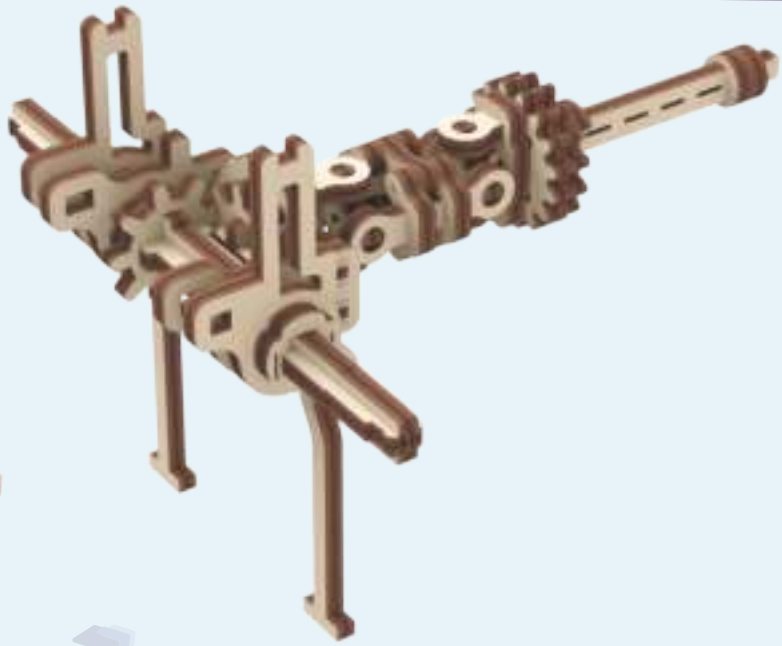
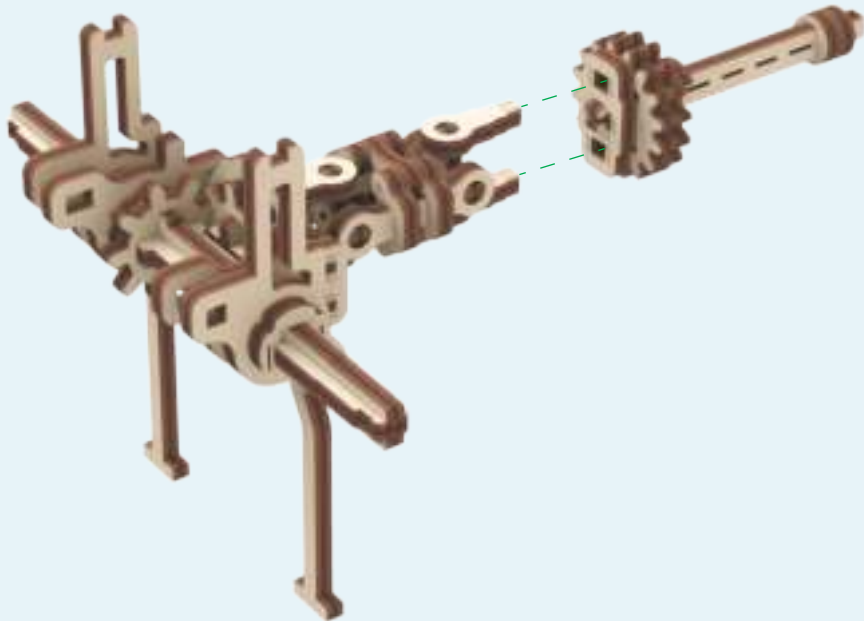

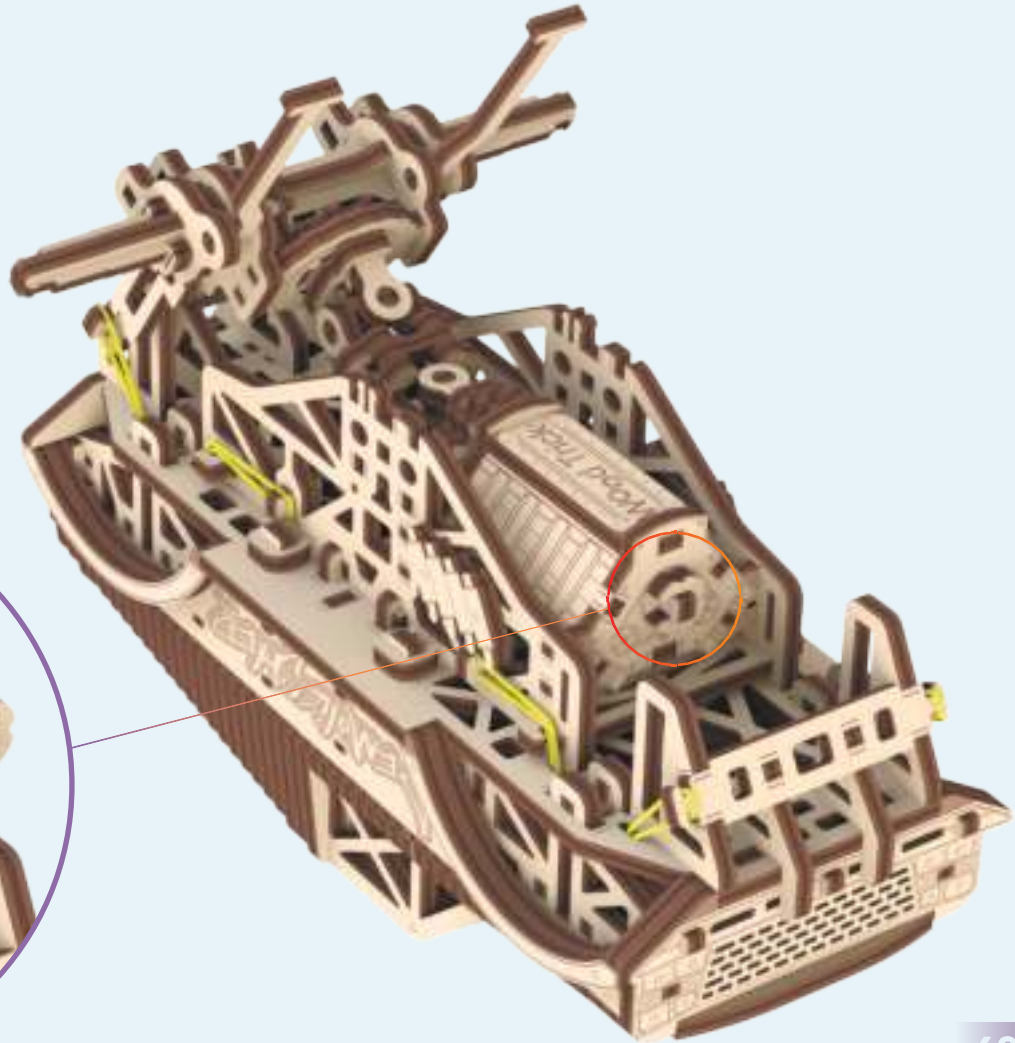
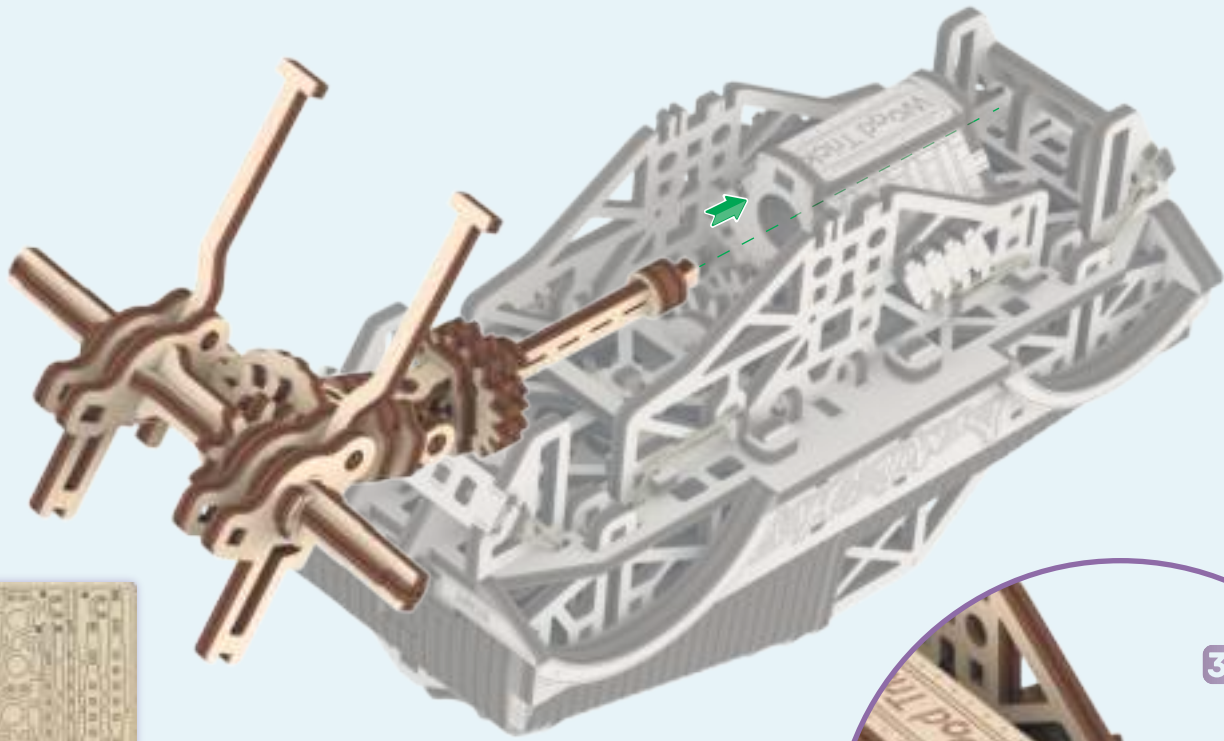
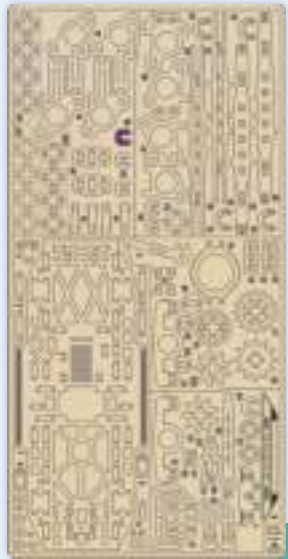

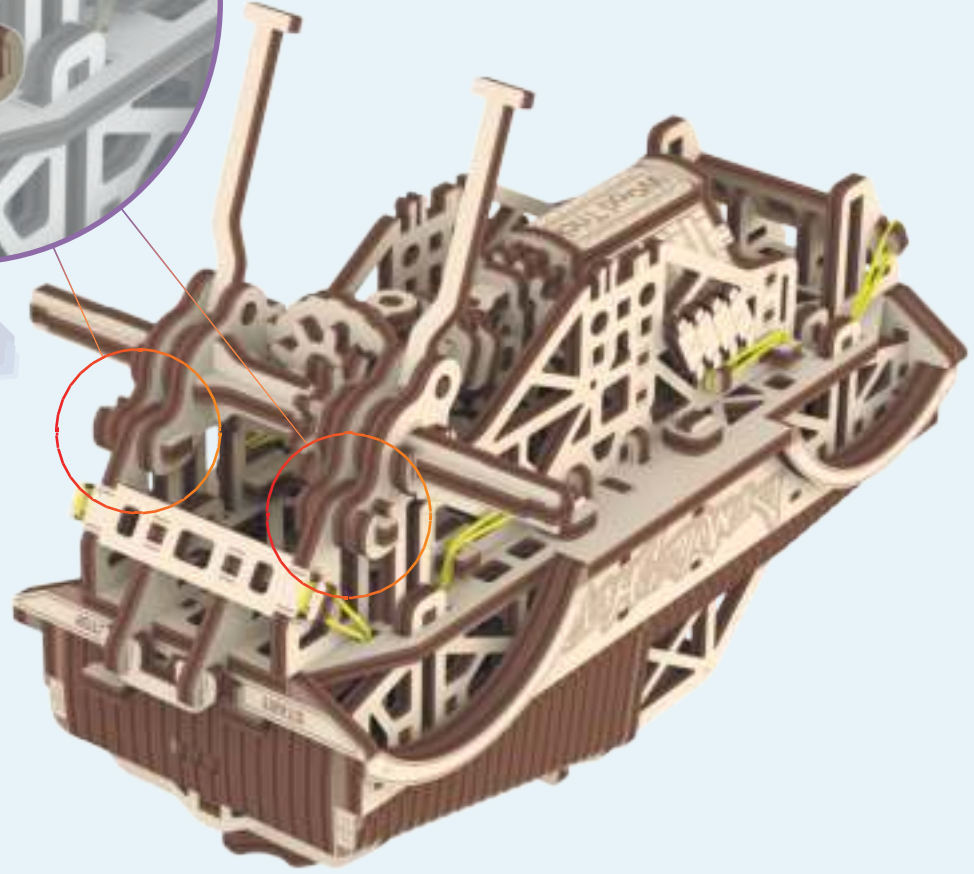
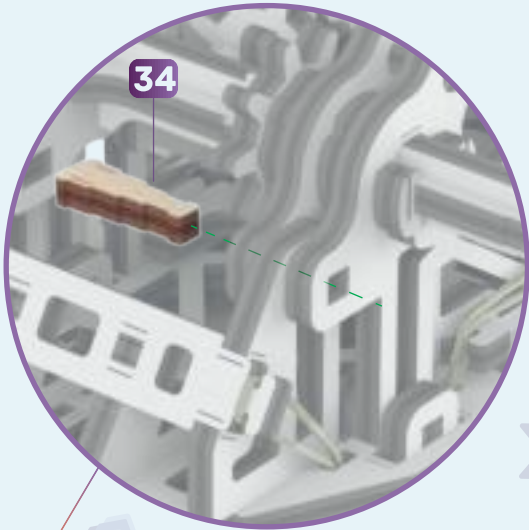
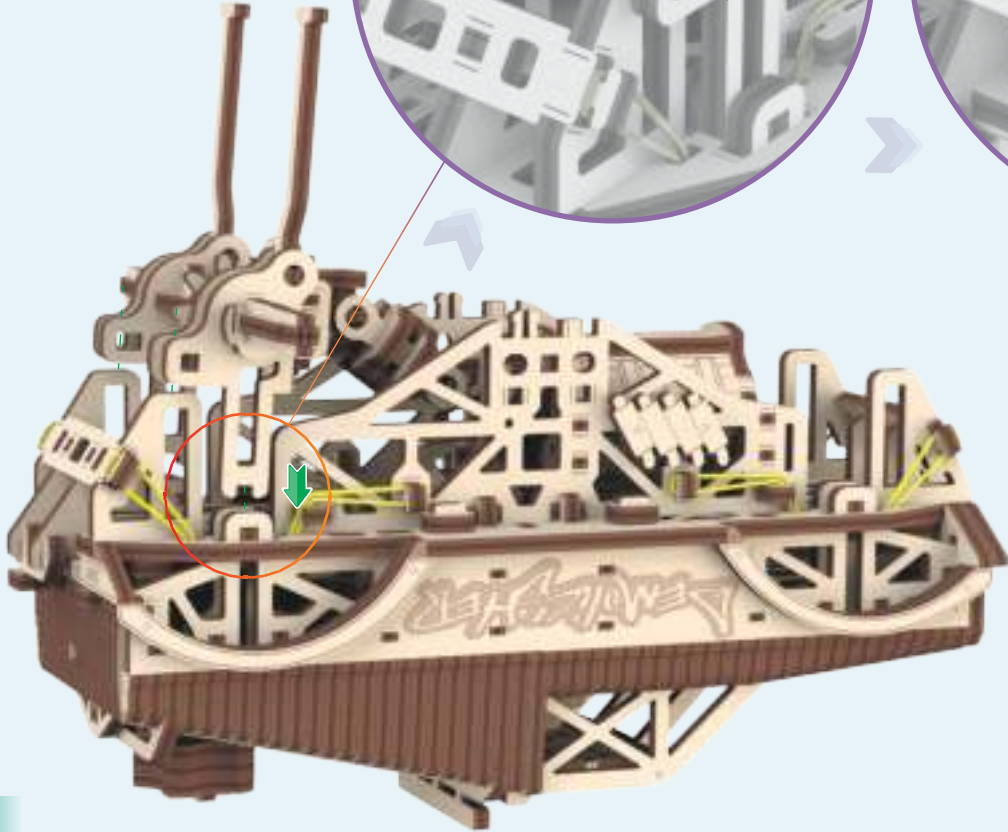
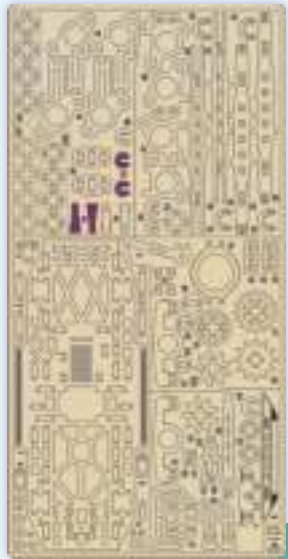

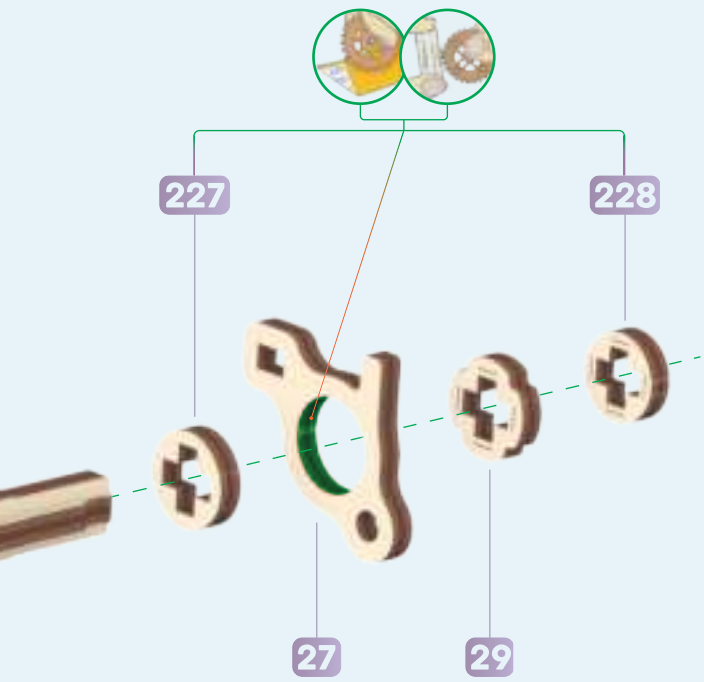
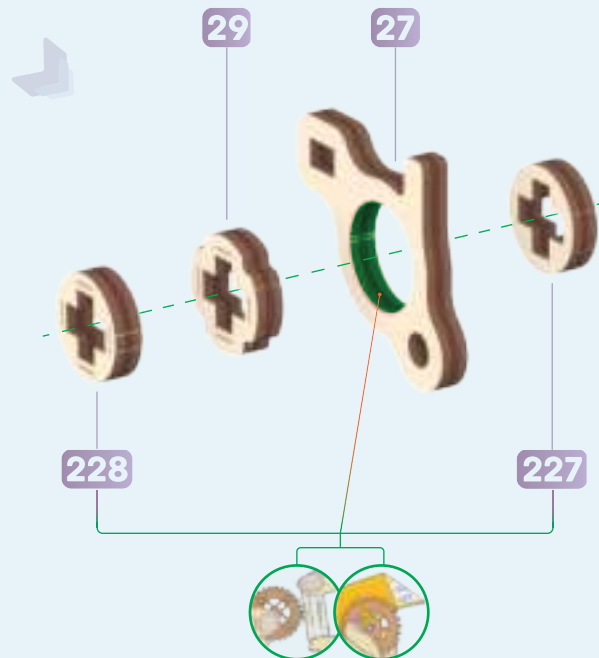
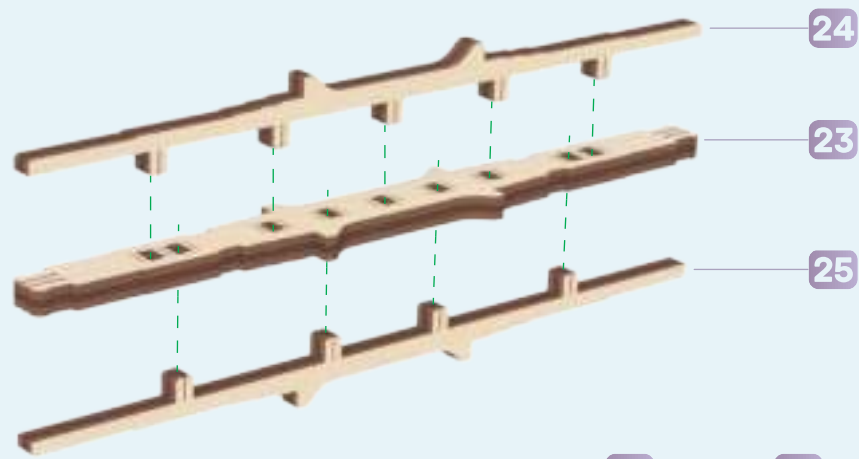

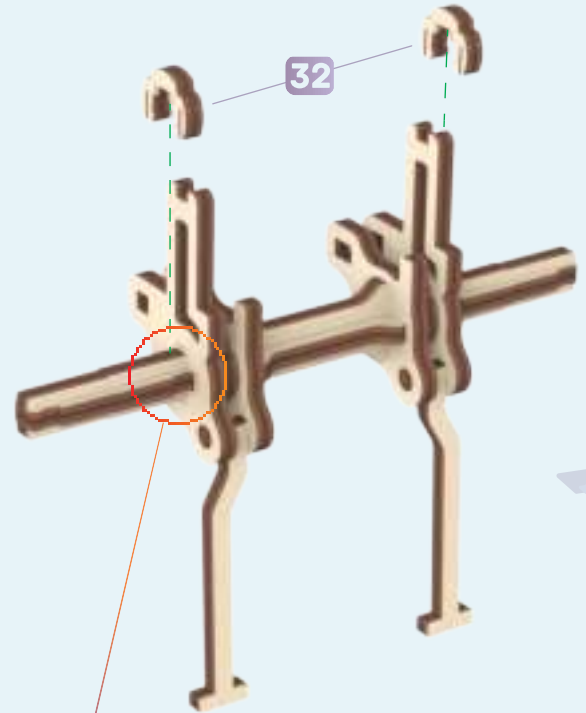
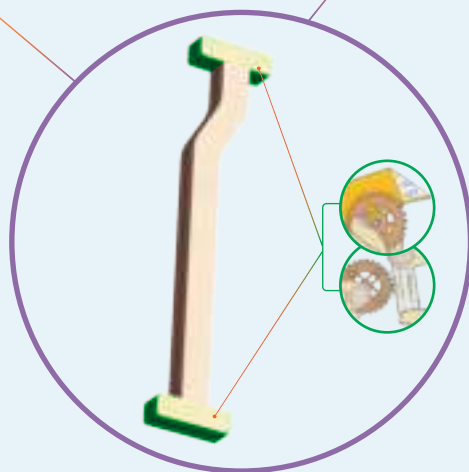
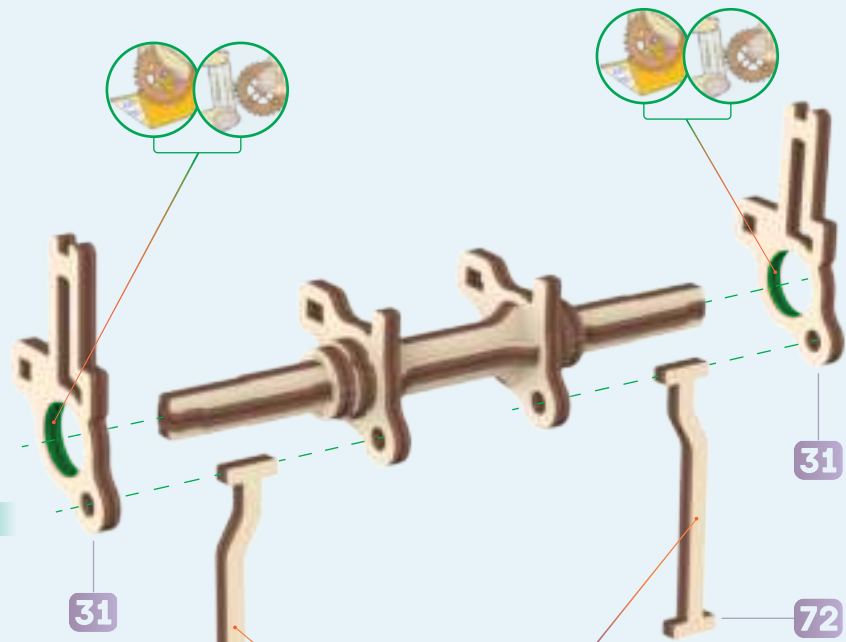



1

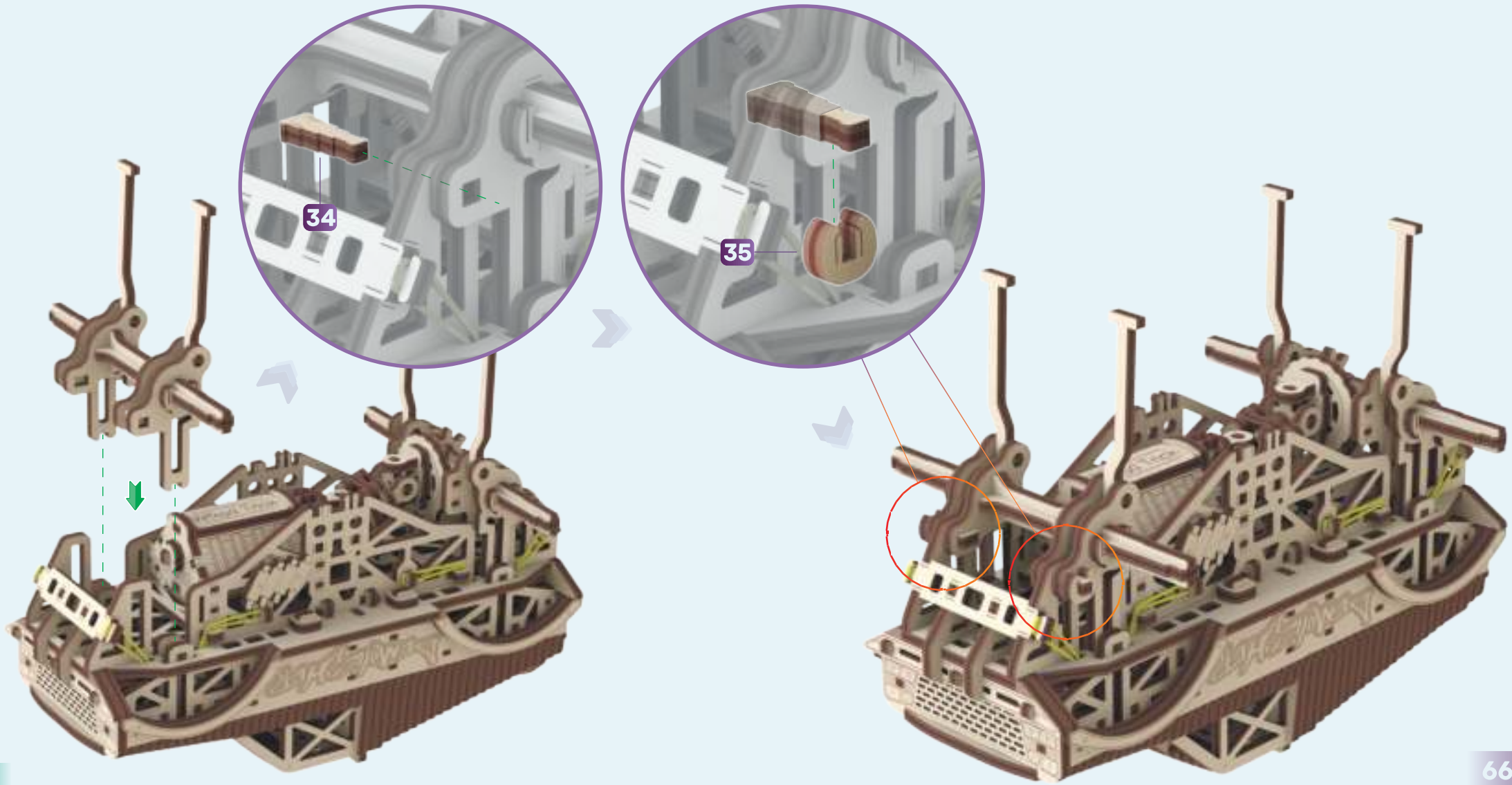

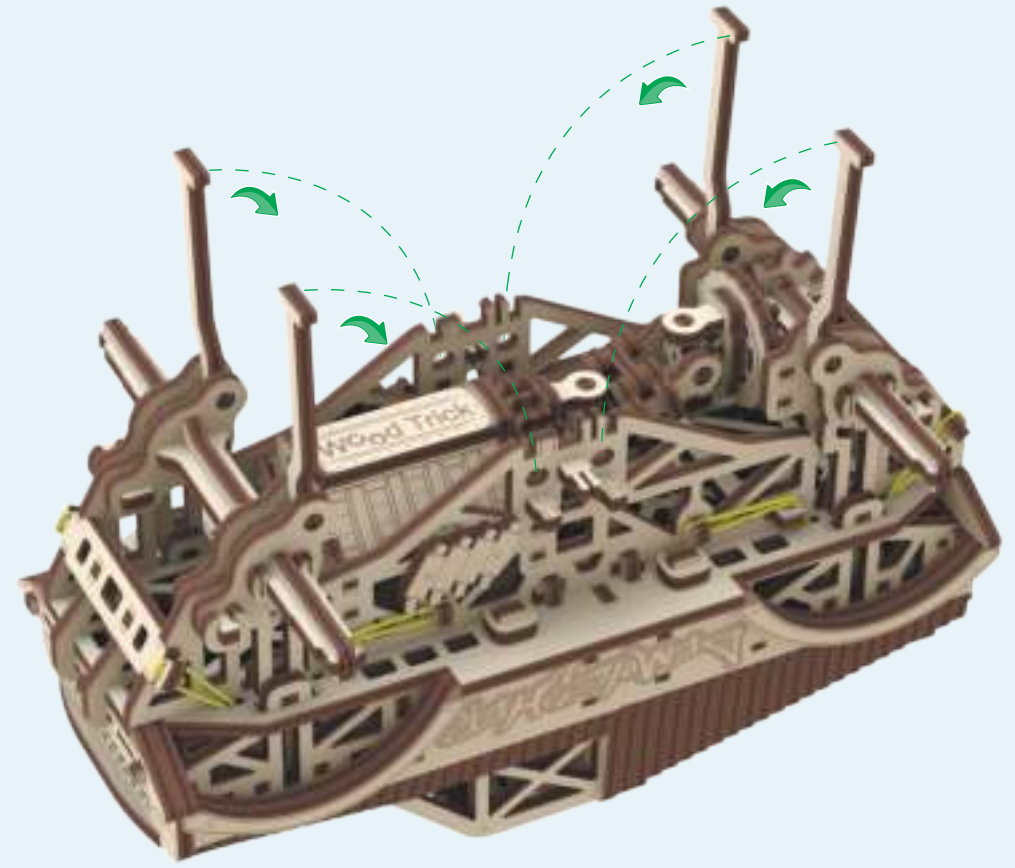
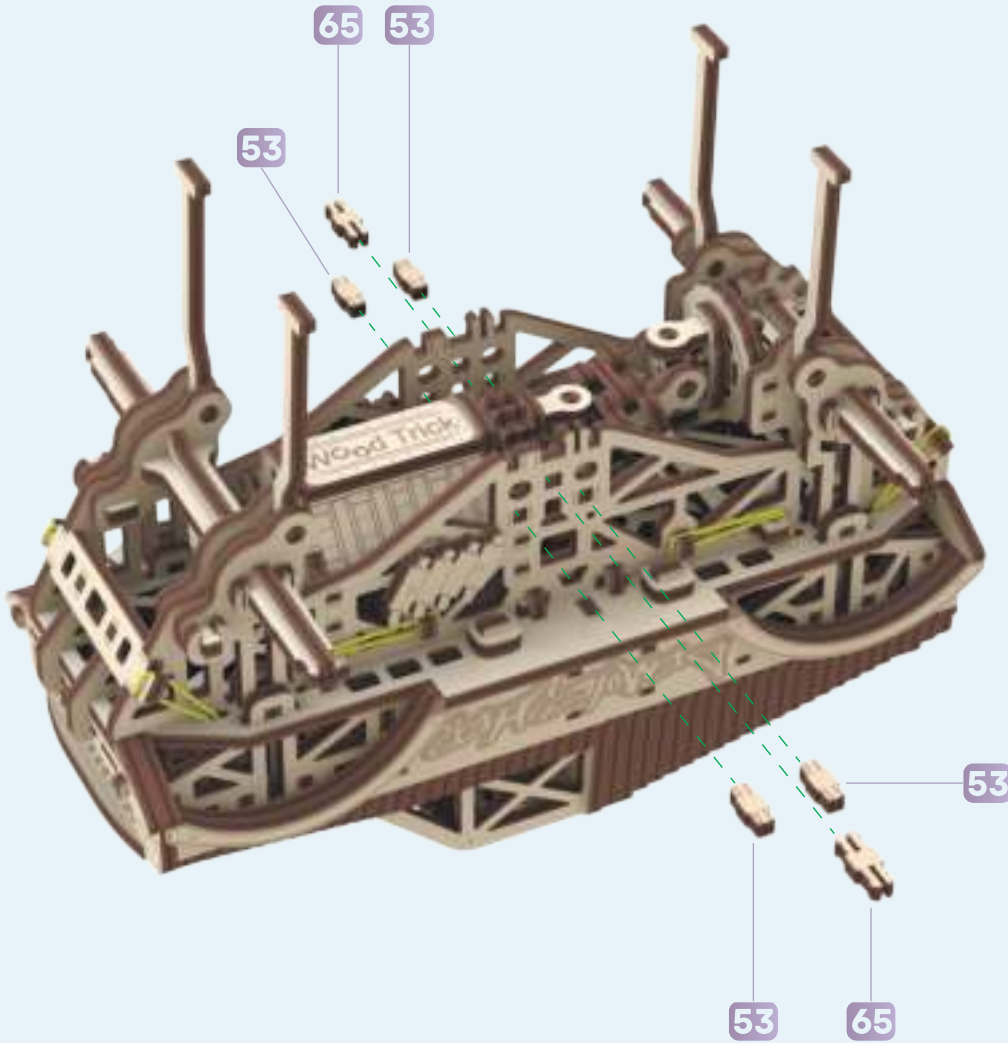



2

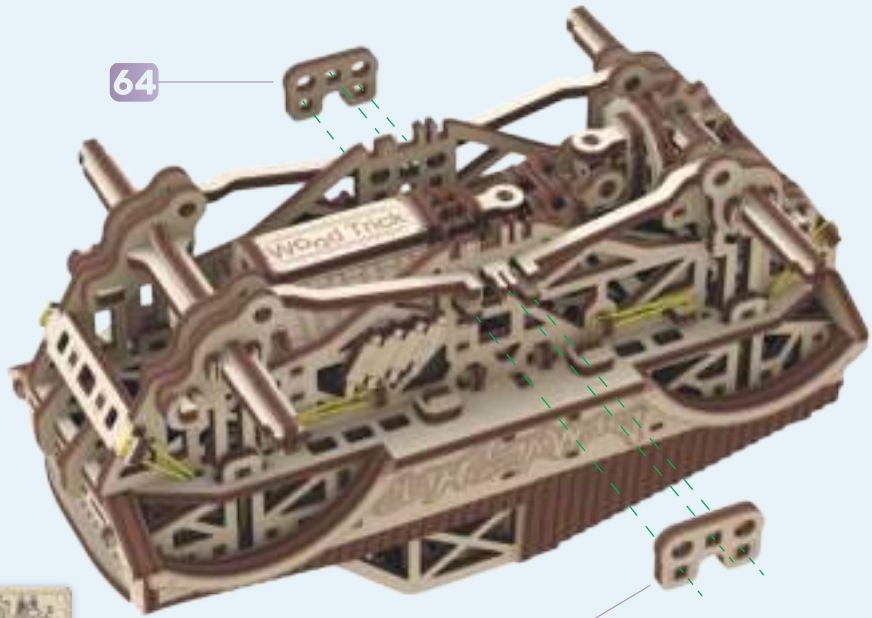

64

64

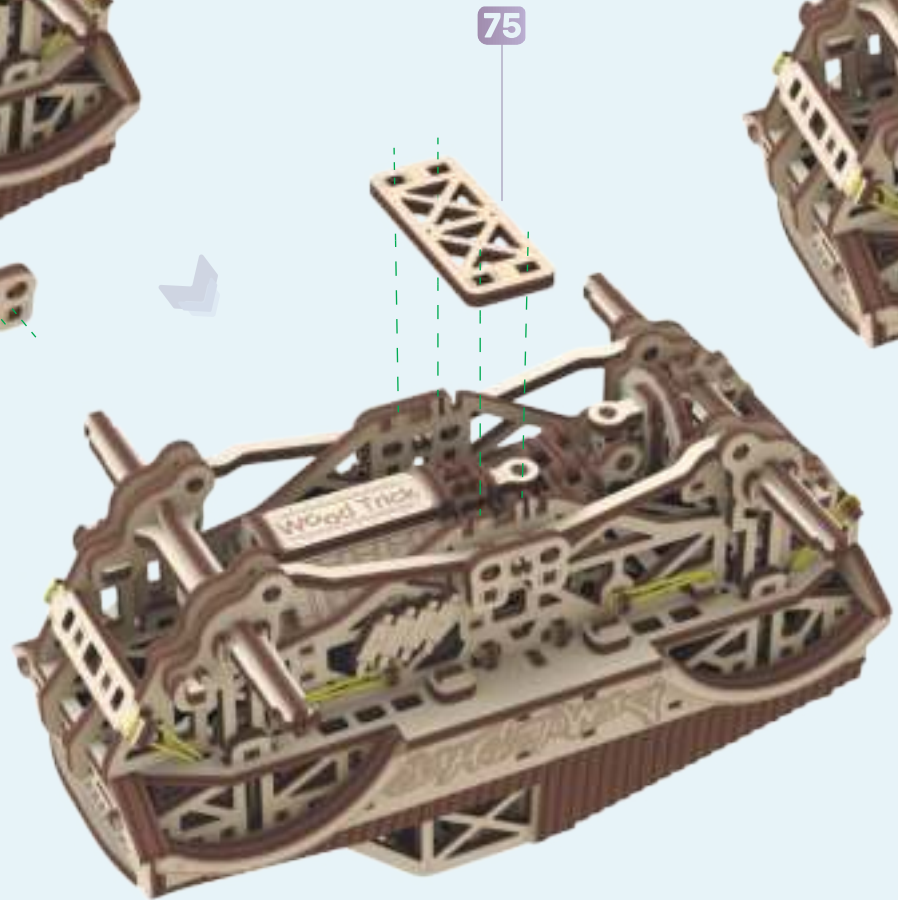

75

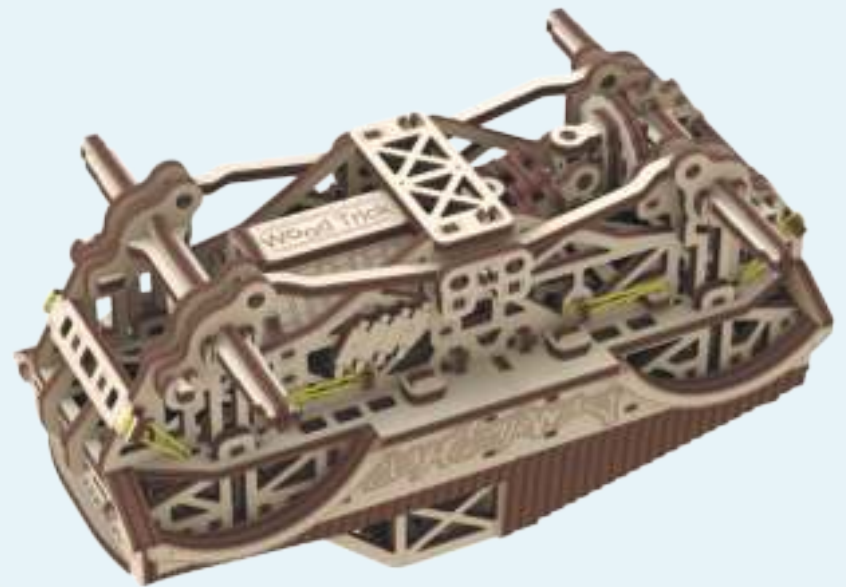

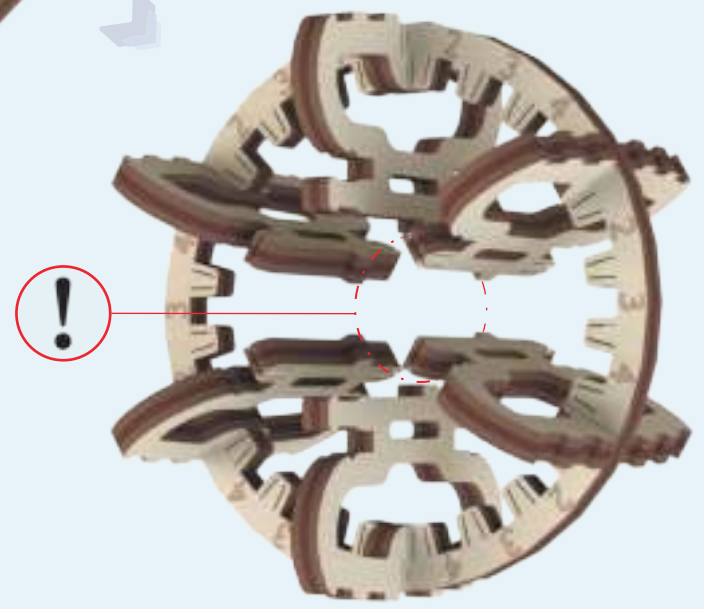
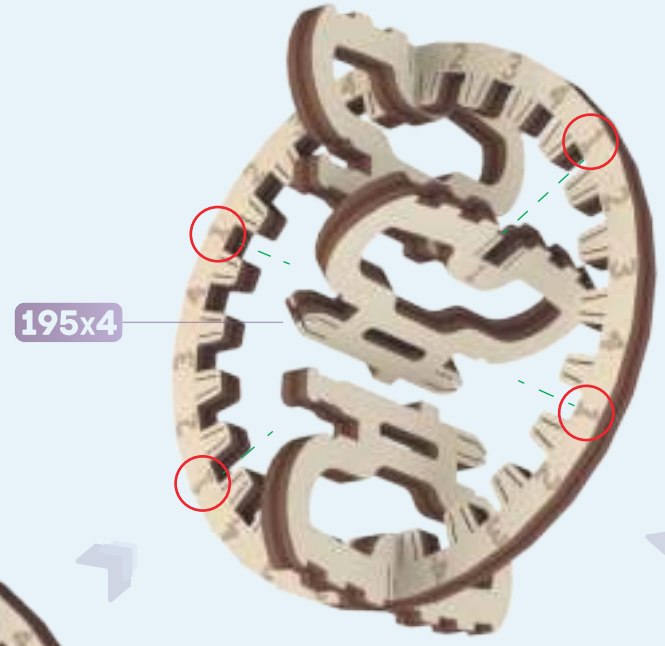
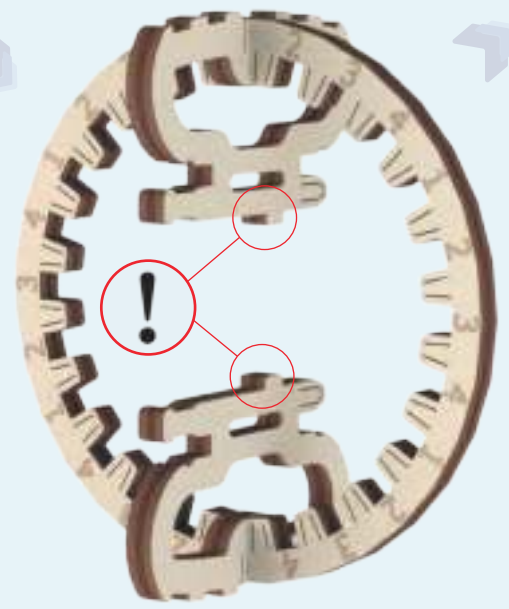
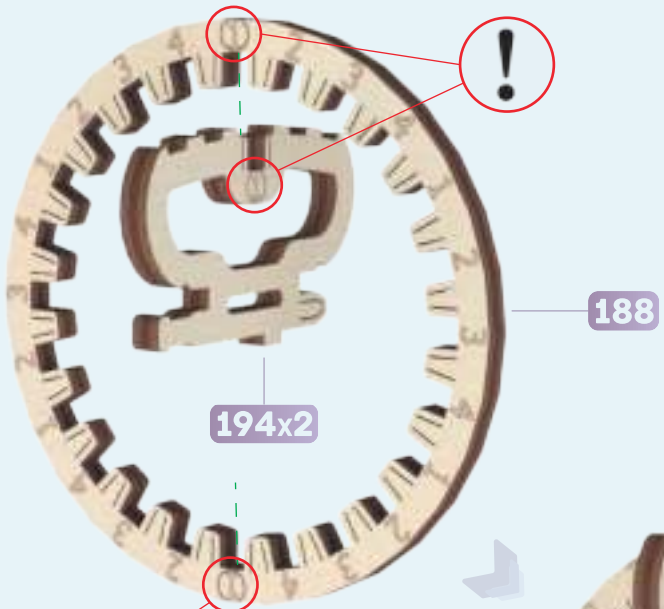



196x6

5

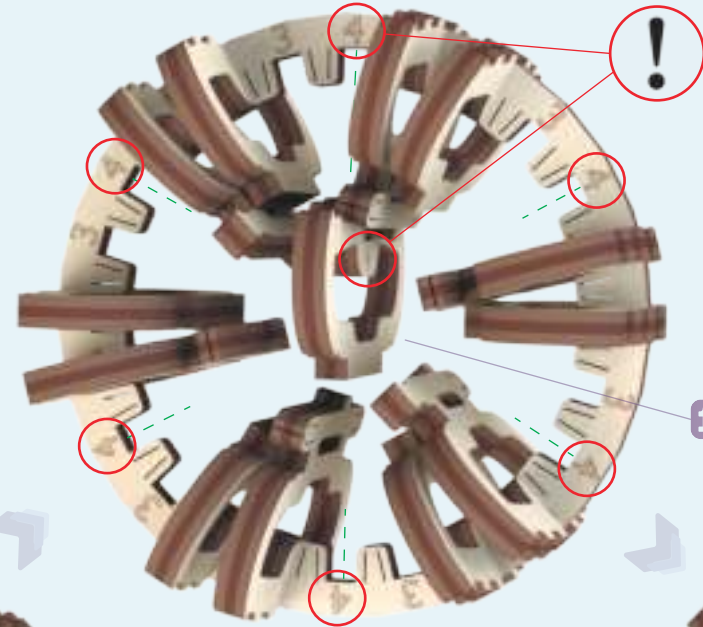
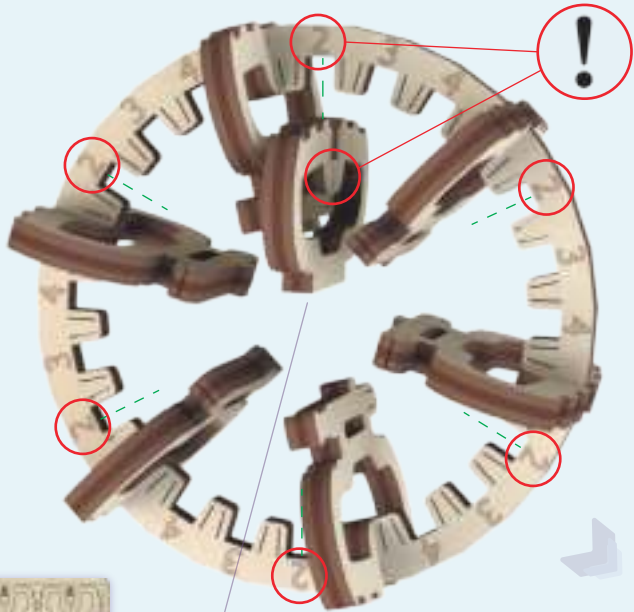

198x6



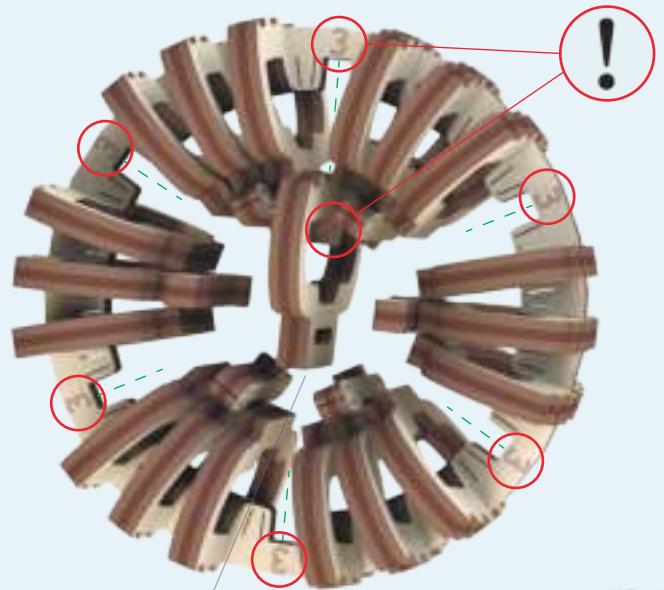

197x6

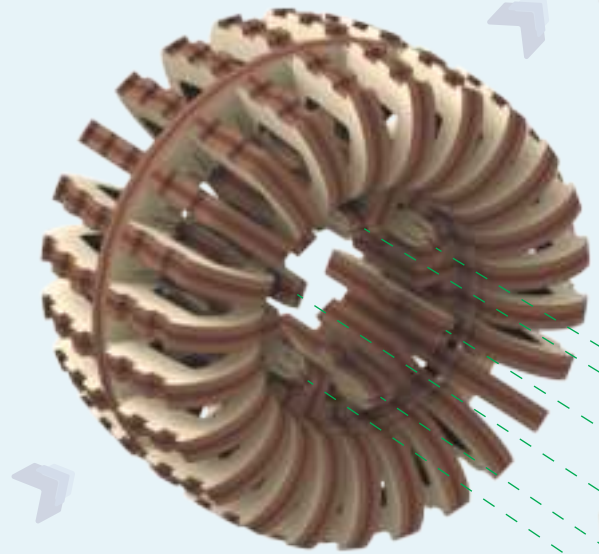

189

199

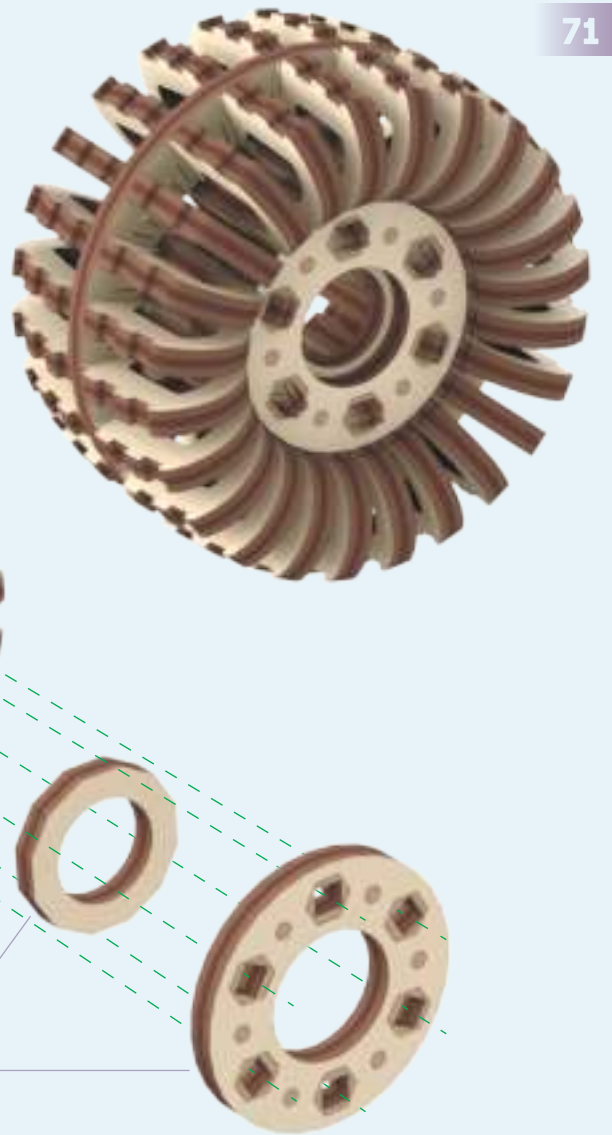





7

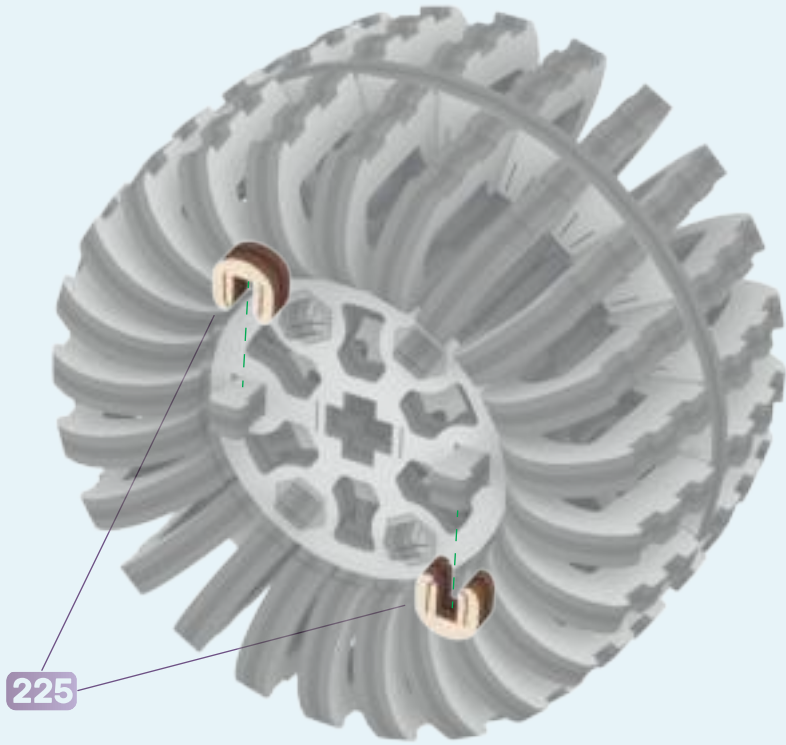

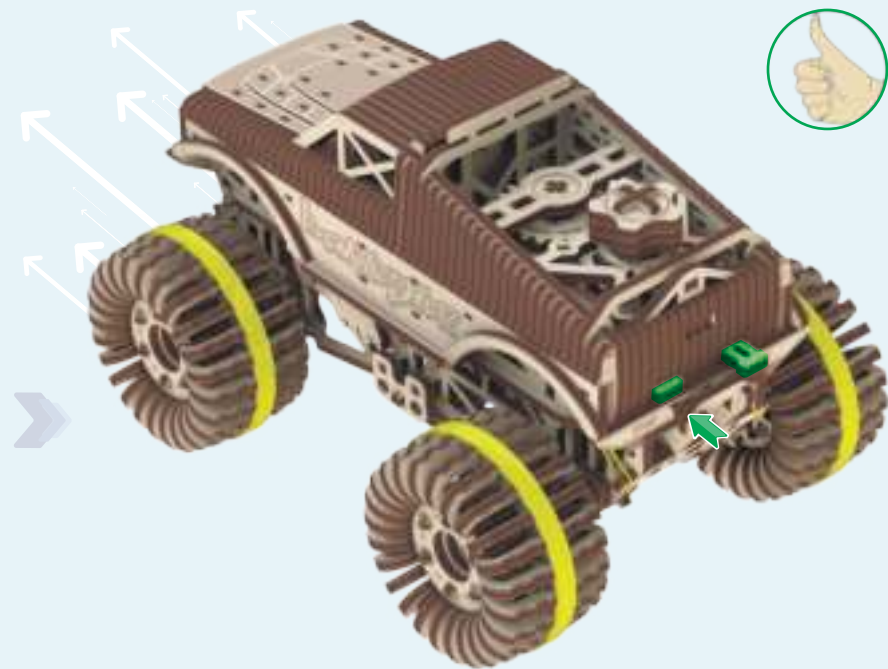
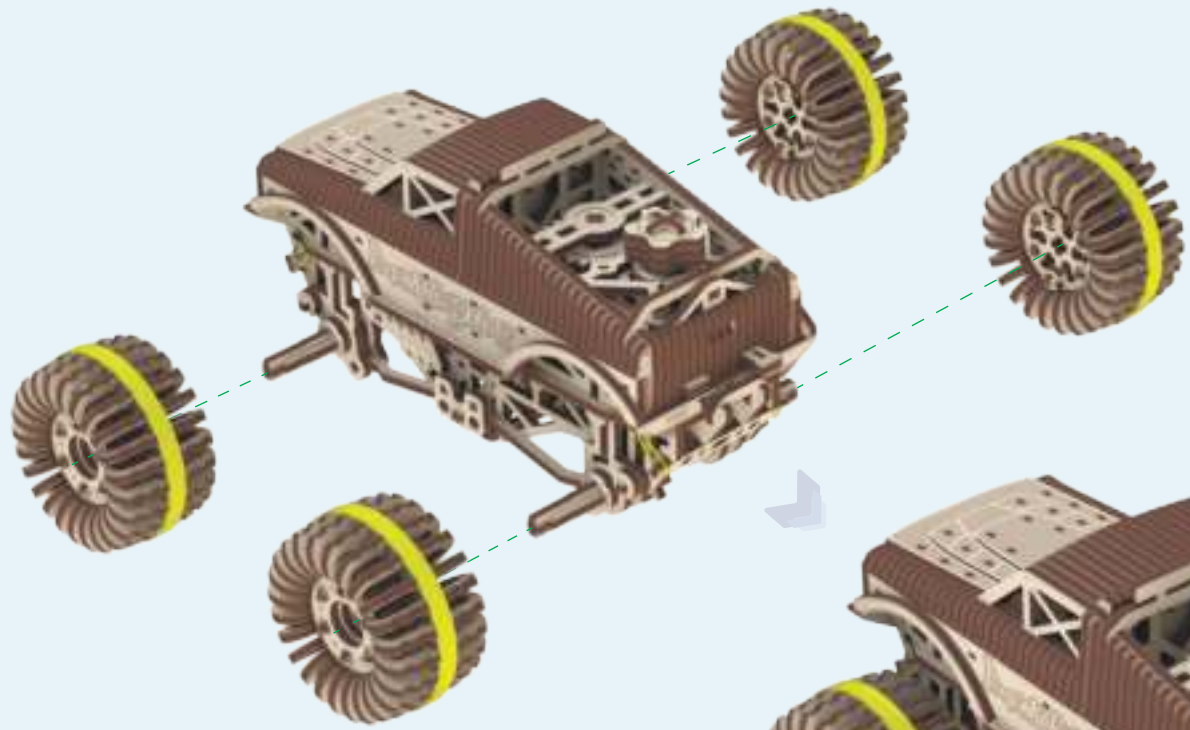

RU Не рекомендуем запускать модель на холостом ходу, поскольку это может привести к поломке пружины!

UA Не рекомендуємо запускати модель на холостому ході, оскільки це може призвести до виведення з ладу пружини!

EN We do not recommend starting the model at idle, as this can lead to breakage of the spring!

DE Wir empfehlen nicht, das Modell im Leerlauf in Bewegung zu setzen, da dies zum Federbruch führen kann!

FR Nous déconseillons de lancer marcher la maquette au ralenti car cela peut amener à la casse du ressort!

ITL Non è consigliato di avviare la macchina a vuoto perché può provocare la rottura della molla!

SP ¡No recomendamos lanzar el modelo a ralentí, ya que esto puede provocar la rotura del resorte!

PL Nie zalecamy uruchamiać urządzenia na biegu jałowym, ponieważ może to doprowadzić do pęknięcia sprężyny!

