

WOOD TRICK

ELECTRIC
SERIES

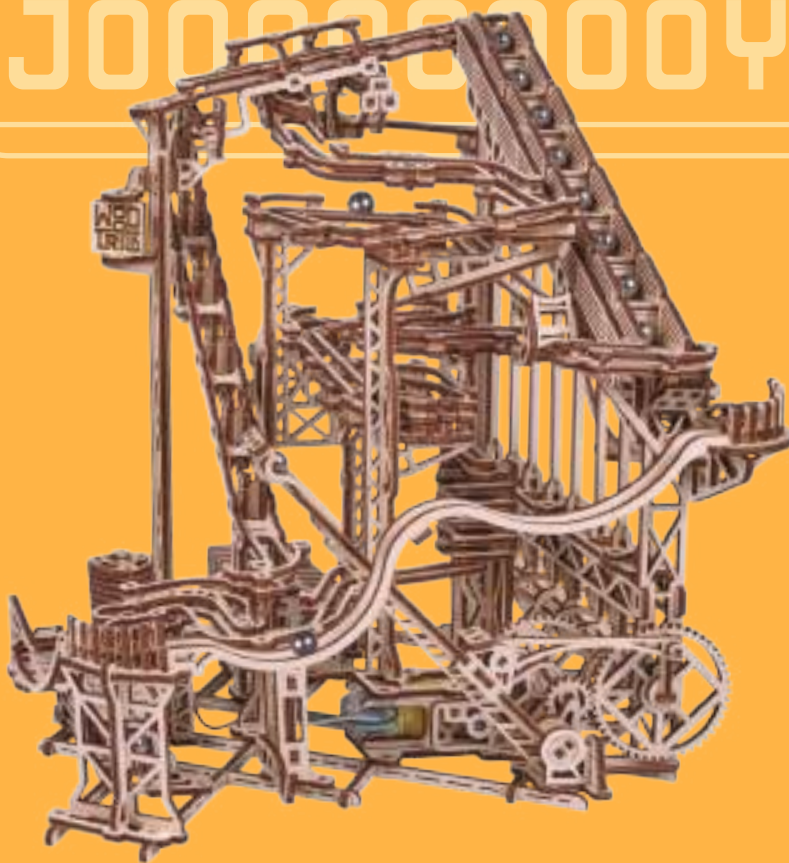

ENGINEERING
JOOROROOY



MECHANICAL MODELS & KITS

SPIRAL MARBLE RUN



5 LEVEL

558
PIECES

WDTK056



ENG Do not set fire to it! **UKR** Не підпалювати! **DEU** Nicht anzünden! **FRA** Ne pas allumer!
POL Nie podpalaj! **ESP** No prender fuego! **ITA** Non dare fuoco!



ENG Caution! Sharp parts! **UKR** Обережно! Гострі деталі! **DEU** Vorsichtig! Scharfe Details!
FRA Attention! Détails tranchants! **POL** Uwaga! Ostre szczegóły! **ESP** Cuidado! Piezas cortantes! **ITA** Attenzione! Dettagli nitidi!

ENG Recommendation: if you have difficulty in connecting parts, treat toothpicks with paraffin. **UKR** Рекомендація: якщо виникли складнощі при скріпленні деталей, обробіть зубочистки парафіном. **DEU** Empfehlung: Wenn Sie Schwierigkeiten haben, Teile zu verbinden, behandeln Sie Zahnstocher mit Paraffin. **FRA** Recommandation: si vous avez des difficultés pièces de fixation, traitez les cure-dents avec de la paraffine. **POL** Zalecenie: jeśli masz trudności z połączeniem części, obsługiwać wykałaczki parafiną. **ESP** Recomendación: si tiene dificultades para fijar piezas, trate mondadientes con parafina. **ITA** Raccomandazione: in caso di difficoltà nel fissare le parti, trattare gli stuzzicadenti con paraffina.

ENG The assembling of constructor does not require to use glue. **UKR** Конструктор не вимагає застосування клею. **DEU** Für die Montage des Konstruktors ist kein Klebstoff erforderlich. **FRA** Aucune colle n'est nécessaire pour monter le constructeur. **POL** Montaż konstruktora odbywa się bez kleju. **ESP** El montaje constructor no requiere el uso de pegamento. **ITA** L'assemblaggio non richiede l'uso di colla.

ENG Fragile details! Be careful when removing the constructor from the card! **UKR** Крихкі деталі! Під час вилучення конструктора з карти будьте обережні! **DEU** Zerbrechliche Details! Seien Sie vorsichtig, wenn Sie den Konstruktor von der Karte entfernen! **FRA** Détails fragiles! Faites attention en retirant les éléments de la construction de la carte! **POL** Krucho szczegóły! Przedmioty należy wyjmować z karty ostrożnie! **ESP** Detalles frágiles! Sea prudente al sacar elementos de mecano del tarjeta! **ITA** Dettagli fragili! Gli elementi vanno estratti dalla scheda con cautela!

ENG All elements that interlock must be sanded with sandpaper and greased with paraffin. **UKR** Всі елементи, що входять у зачеплення необхідно зачистити наждачним папером і змастити парафіном. **DEU** Alle eingreifenden Teile müssen mit Sandpapier gereinigt und mit Paraffin eingefettet werden. **FRA** Il faut nettoyer tous les éléments de l'accrochage à l'aide du papier-meri et les traiter avec de la paraffine. **POL** Wszystkie zaczepione elementy należy oczyścić papierem ściernym i nasmarować parafiną. **ESP** Todos los elementos que se enganchan deben limpiarse con papel de lija y engrasarse con parafina. **ITA** Tutti gli elementi agganciati devono essere puliti con carta vetrata e ingrassati con paraffina.

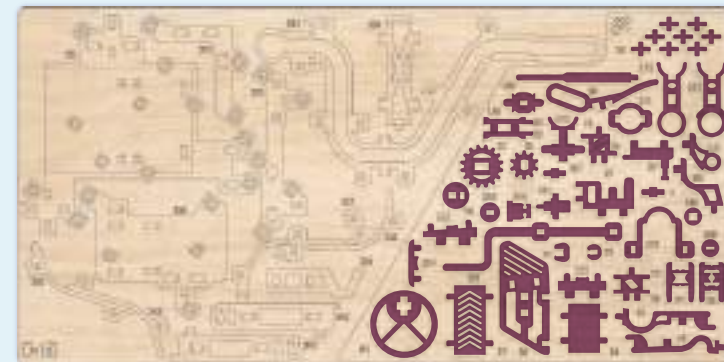
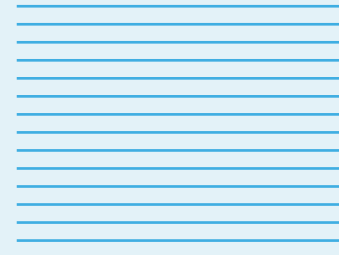

11

ENG Spare parts. **UKR** Запасні деталі. **DEU** Ersatzteile. **FRA** Pièces de rechange. **POL** Części zamienne. **ESP** Repuestos. **ITA** Pezzi di ricambio.

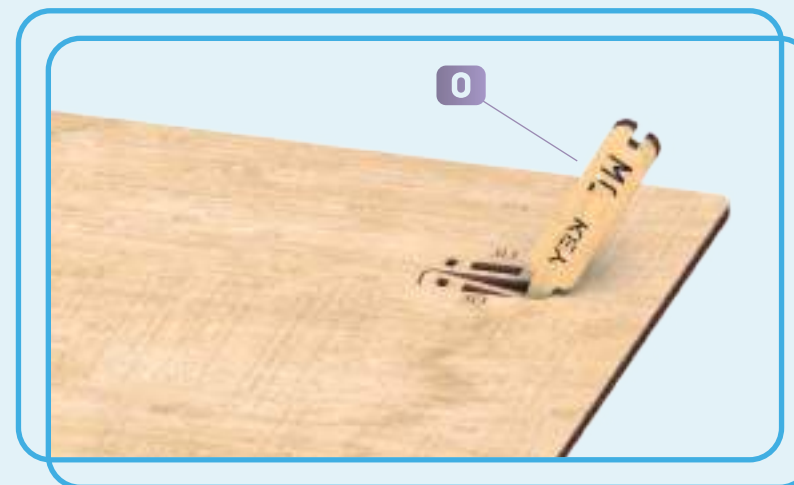

3

ENG Auxiliary tool for assembling or measuring distances. **UKR** Допоміжний інструмент для збірки або вимірювання відстаней. **DEU** Hilfswerkzeug zum Montieren oder Messen von Abständen. **FRA** Outil auxiliaire pour assembler ou mesurer des distances. **POL** Narzędzie pomocnicze do montażu lub pomiaru odległości. **ESP** Herramienta auxiliar para ensamblar o medir distancias. **ITA** Strumento ausiliario per l'assemblaggio o la misurazione delle distanze.



ENG Remove burrs. **UKR** Видалити задирки. **DEU** Niednägel entfernen. **FRA** Enlever les bavures. **POL** Usuń zadziory. **ESP** Quitar rebabas. **ITA** Eliminare le bave.



ENG Note! **UKR** Звернути увагу! **DEU** Aufgepasst!
FRA Faites attention! **POL** Uwaga! **ESP** ¡Presta atención!
ITA Presta attenzione!

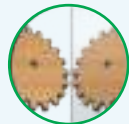

ENG Assembly in mirror reflection. **UKR** Збірка в дзеркальному відображенні. **DEU** Montage in spiegelreflexion. **FRA** Assemblage en réflexion spéculaire. **POL** Montaż w odbiciu lustrzanym. **ESP** Montaje en reflexión especular. **ITA** Assemblaggio in riflessione speculare.



ENG Caution, fragile detail! **UKR** Обережно, крихка деталь!
DEU Vorsicht, zerbrechliches Detail! **FRA** Attention, détail fragile!
POL Uwaga, delikatny szczegół. **ESP** ¡Atención, frágiles detalles!
ITA Attenzione, dettaglio fragile!



ENG Lubricate with paraffin. **UKR** Змастити парафіном.
DEU Mit dem Paraffin schmieren. **FRA** Lubrifier à la paraffine.
POL Nasmaruj parafiną. **ESP** Lubricar con parafina.
ITA Lubrificare con paraffina.



ENG Assembly is completed. **UKR** Збірка закінчена.
DEU Montage abgeschlossen. **FRA** Assemblée terminée.
POL Montaż zakończony. **ESP** Ensamblaje completada.
ITA L'assemblaggio è finito.

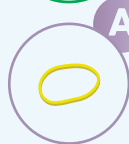

ENG Little rubber band. **UKR** Маленька резинка. **DEU** Kleines Gummiband. **FRA** Petit élastique. **POL** Mała gumka. **ESP** De goma pequeña. **ITA** Piccola gomma.



ENG Design kit can be tightly connected in some places, so that the assembled model has solidity and reliability. We recommend using pliers and box cutter for a more convenient design kit assembly. **UKR** Конструктор може в деяких місцях туго з'єднатися, для того, щоб зібрана модель мала міцність та надійність. Для більш зручної збірки конструктора, рекомендуємо використовувати плоскогубці та канцелярський ніж. **DEU** Der Konstruktor kann an einigen Stellen keine gute Verbindung herstellen, so daß das zusammengebaute Modell eine ausreichende Festigkeit und Zuverlässigkeit aufweist. Für eine bequemere Montage des Konstrukteurs empfehlen wir die Verwendung einer Zange und eines Schreibwarenmessers. **FRA** Le jeu de construction peut être étroitement connecté à certains endroits, pour que le modèle assemblé soit solide et fiable. Pour un assemblage plus pratique de jeu de construction, nous vous recommandons d'utiliser une pince et un couteau à papeterie. **POL** Le jeu de construction peut être étroitement connecté à certains endroits, pour que le modèle assemblé soit solide et fiable. Pour un assemblage plus pratique de jeu de construction, nous vous recommandons d'utiliser une pince et un couteau à papeterie. **ESP** Le jeu de construction peut être étroitement connecté à certains endroits, pour que le modèle assemblé soit solide et fiable. Pour un assemblage plus pratique de jeu de construction, nous vous recommandons d'utiliser une pince et un couteau à papeterie. **ITA** Le jeu de construction peut être étroitement connecté à certains endroits, pour que le modèle assemblé soit solide et fiable. Pour un assemblage plus pratique de jeu de construction, nous vous recommandons d'utiliser une pince et un couteau à papeterie.

ENG Warning! For the correct operation of this model, it is necessary to clean carefully and to lubricate all rubbing parts with paraffin during assembly. All mechanisms must rotate freely. **UKR** Увага! Для коректної роботи даної моделі, необхідно при збірці ретельно зачищати, змащувати парафіном усі деталі, які труться. Усі механізми повинні вільно обертатися. **DEU** Hinweis! Für einen korrekten Betrieb dieses Modells ist bei dem Zusammenbau erforderlich, alle Reibteile sorgfältig auszuschrubben und mit Paraffin zu schmieren. Alle Bauteile sollen sich frei drehen. **FRA** Attention ! Pour le bon fonctionnement de ce modèle, il est nécessaire lors du montage de nettoyer et lubrifier soigneusement toutes les pièces de friction avec de la paraffine. Tous les mécanismes doivent tourner librement. **POL** Uwaga! Aby ten model działał prawidłowo, podczas montażu wszystkie detale trące muszą być dokładnie oczyszczone i nasmarowane parafiną. Wszystkie mechanizmy muszą się swobodnie obracać. **ESP** ¡Atención! Para el funcionamiento adecuado de este modelo a la hora de ensamblaje se recomienda alisar y lubricar cuidadosamente con parafina todos los detalles frotantes. Todos los mecanismos deben girar libremente. **ITA** Attenzione! Per il corretto funzionamento di questo modello, durante il montaggio, è necessario pulire e lubrificare accuratamente tutte le parti di sfregamento con paraffina. Tutti i meccanismi devono ruotare liberamente.

A

EN - An engine
 UA - Мотор
 DE - Motor
 FR - Le moteur
 IT - Motore
 ES - Motor
 PL - Silnika



B

EN - Button
 UA - Кнопка
 DE - Starttaste
 FR - Le Bouton
 IT - Il Pulsante
 ES - El Botón
 PL - Przycisk



C

EN - Battery compartment for 4 AA batteries
 UA - Батарейний відсік на 4 батарейки AA
 DE - Batteriefach für 4 AA-Batterien
 FR - Baie pour 4 piles AA
 IT - Unità a batteria per 4 batterie AA
 ES - Unidad a batería per 4 baterie AA
 PL - Compartmento de pilas para 4 pilas AA



D

EN - Metal ball
 UA - Металева кулька
 DE - Metallkugel
 FR - Boule en métal
 IT - Sfera di metallo
 ES - Bola de metal
 PL - Metalowa kula



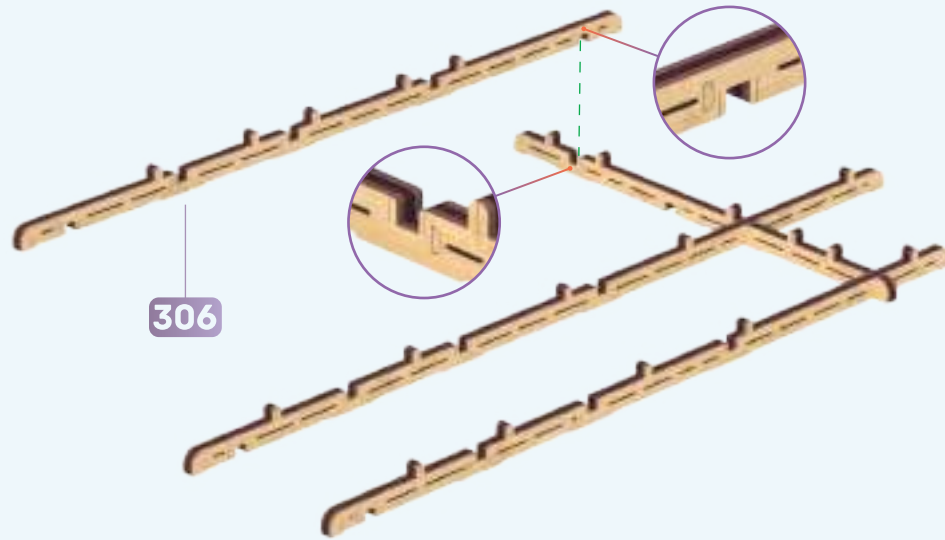
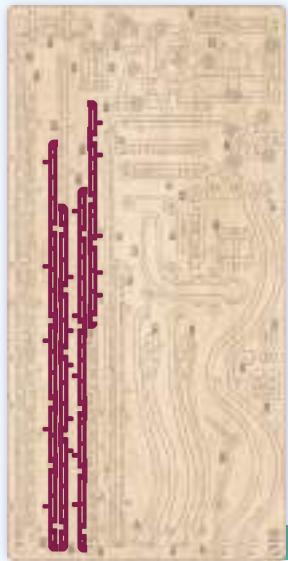
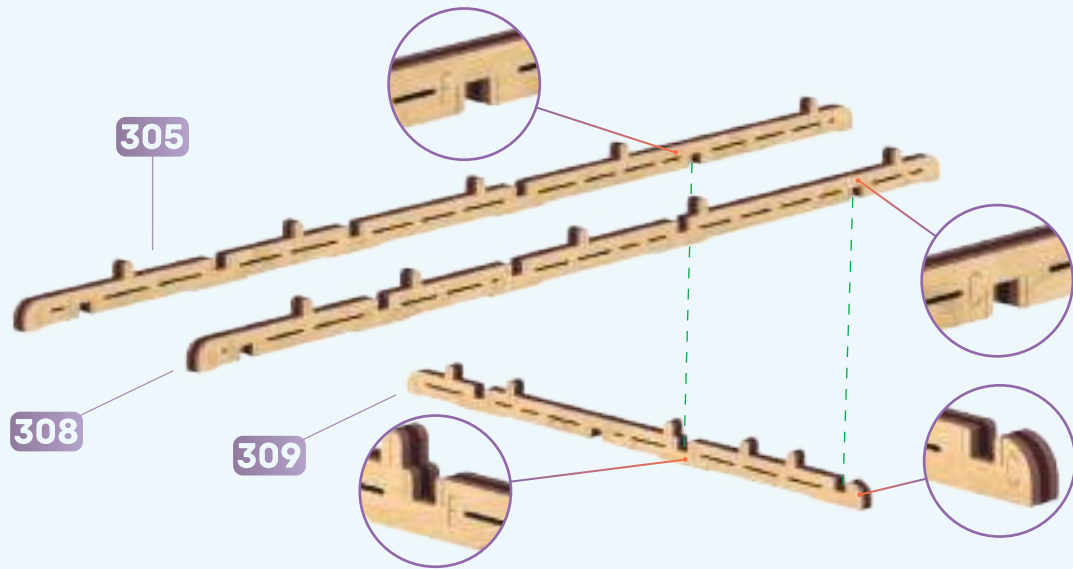

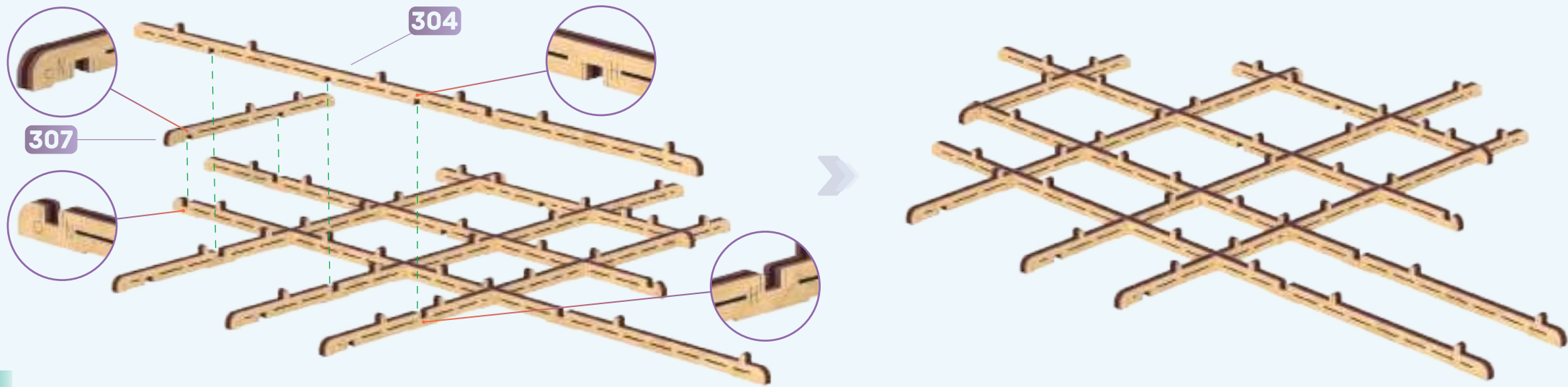
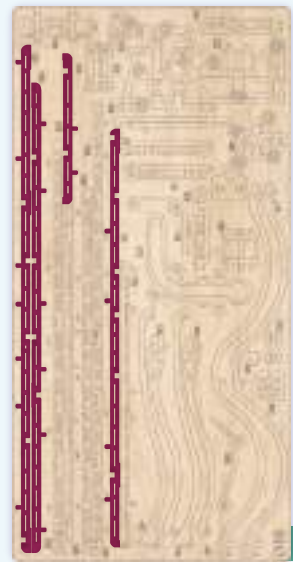
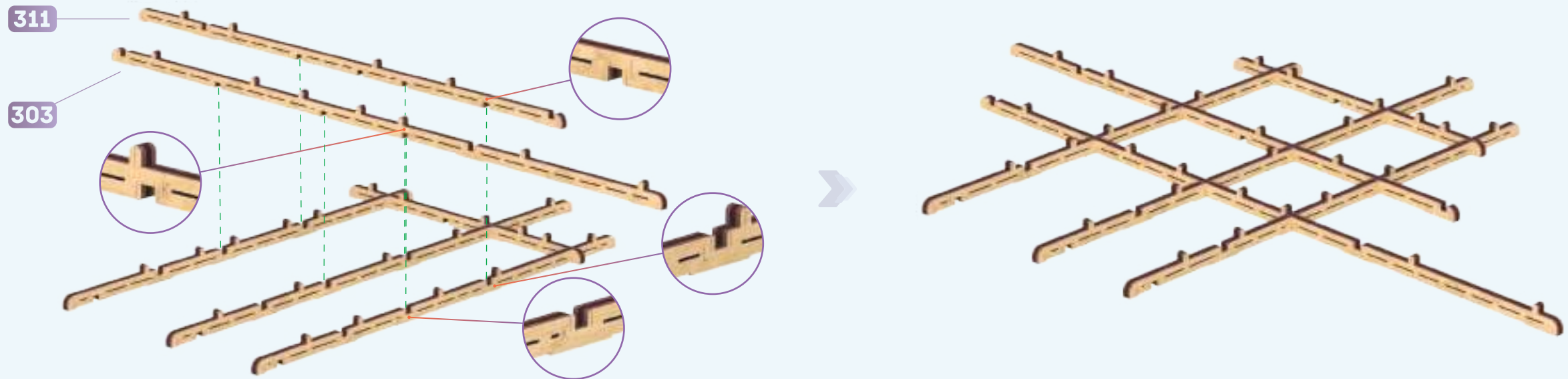

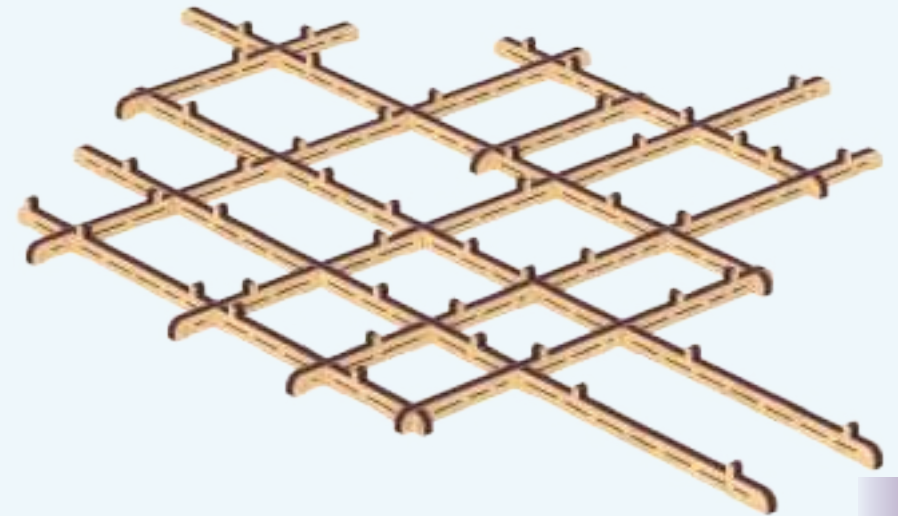
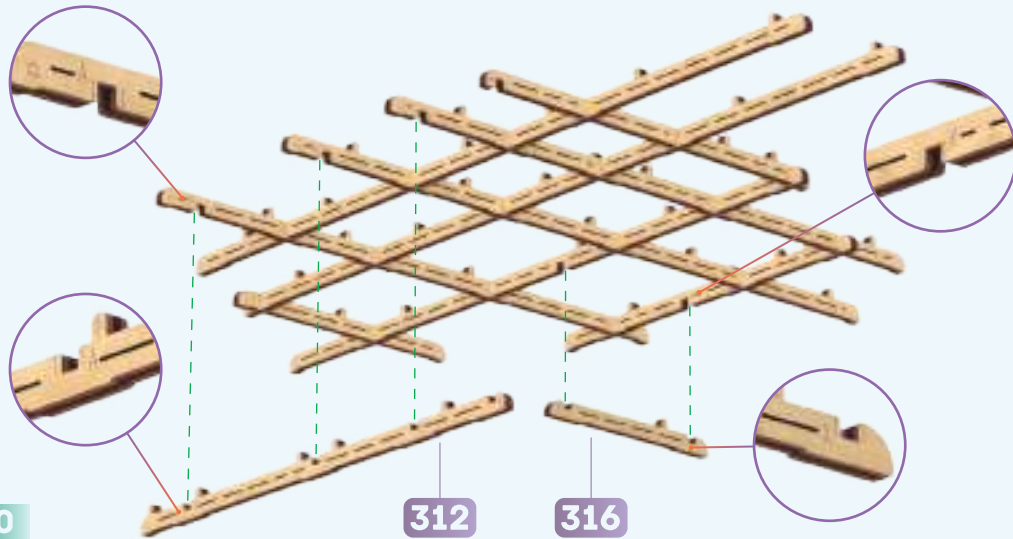
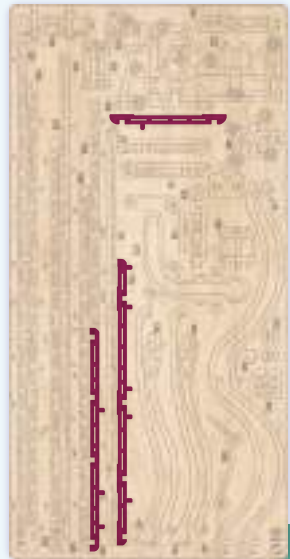
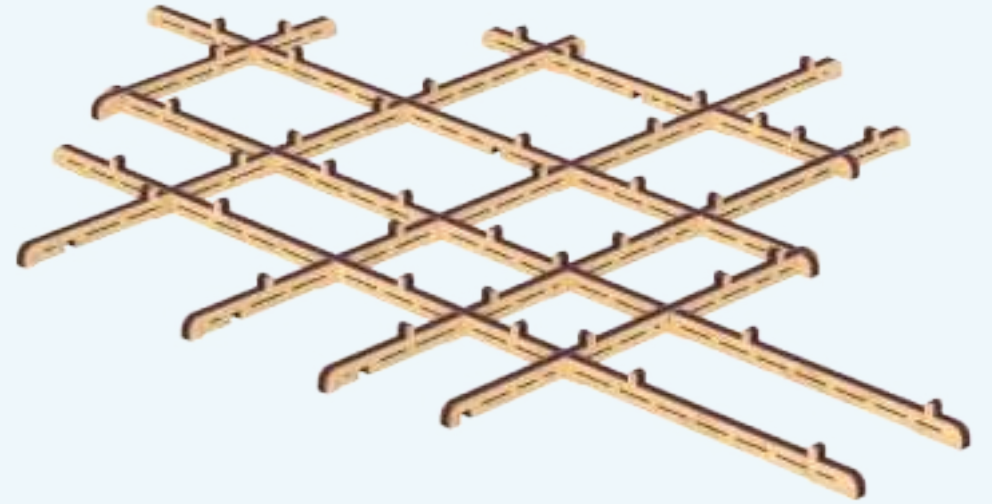
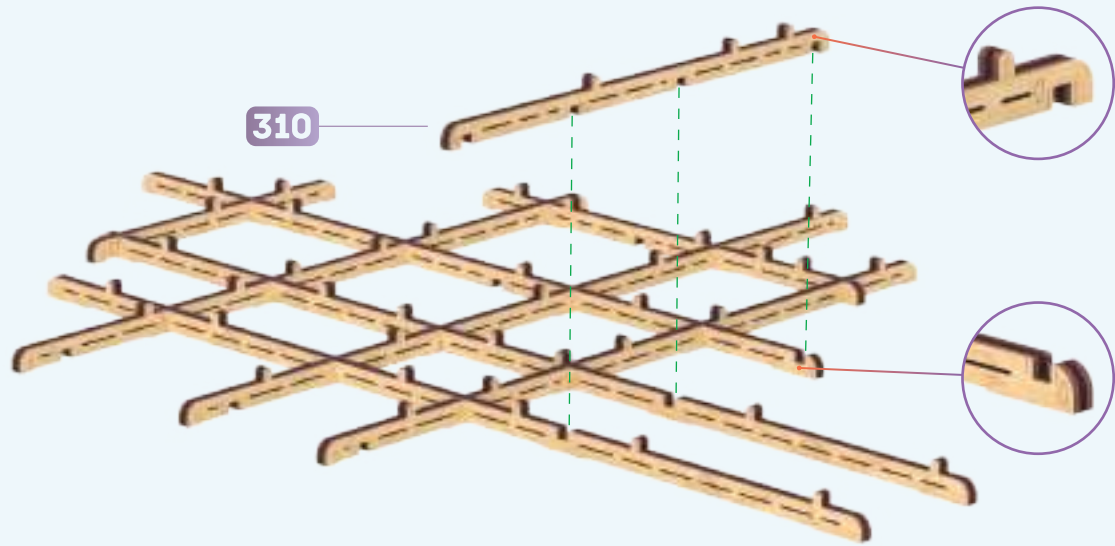

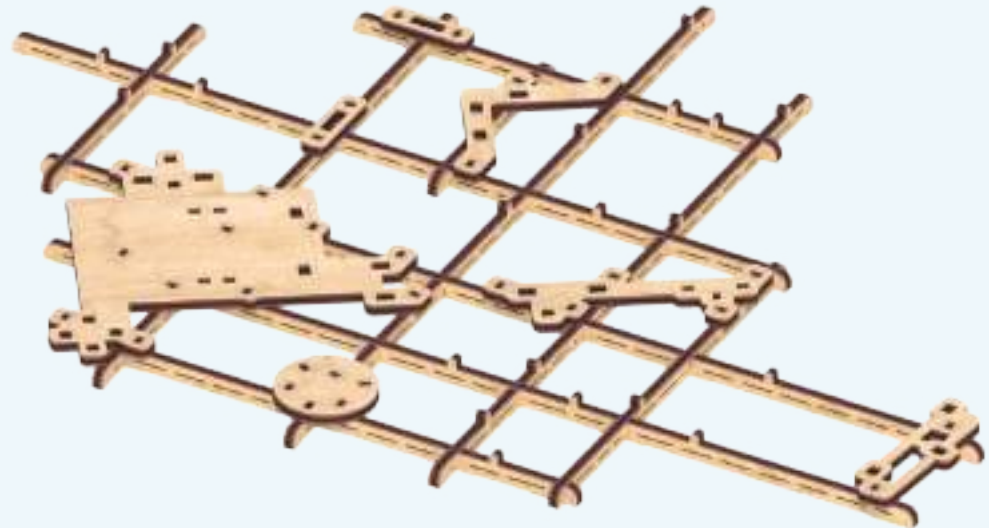
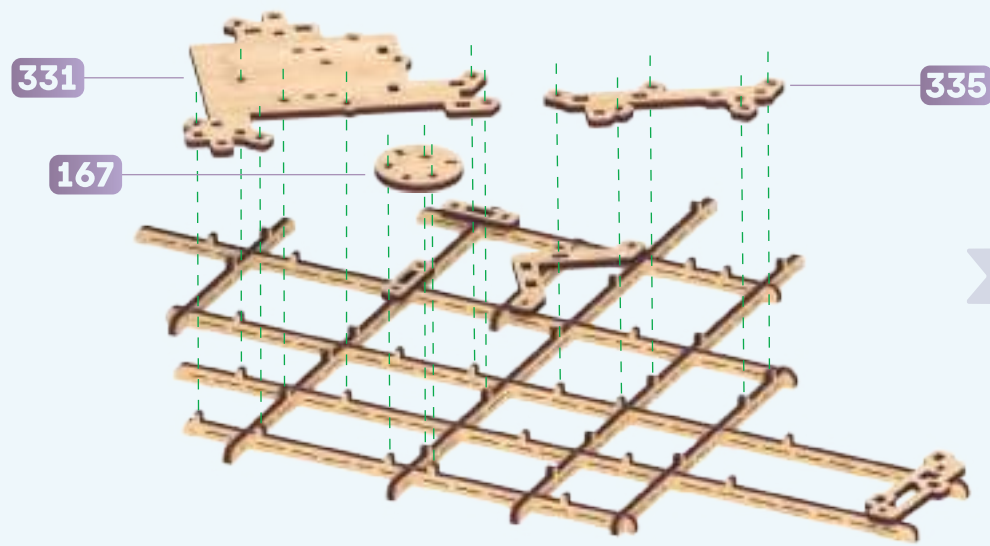
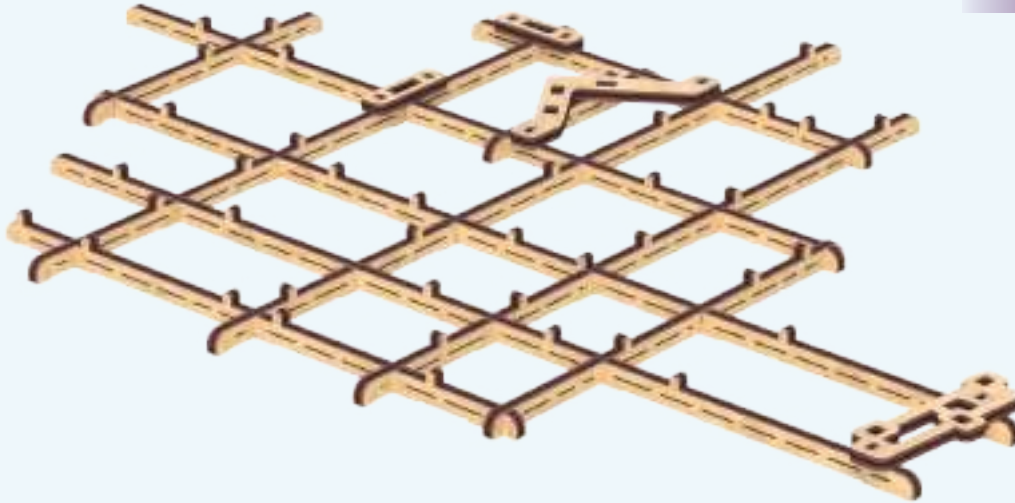
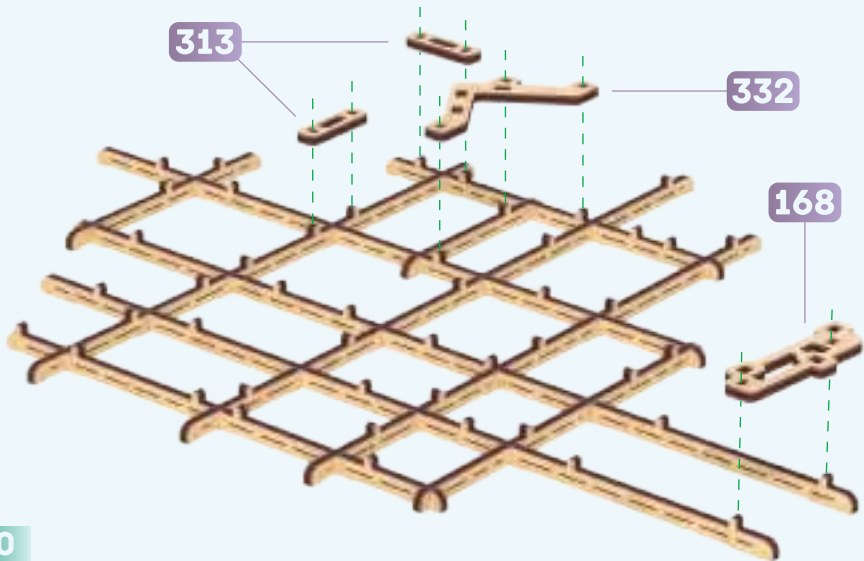
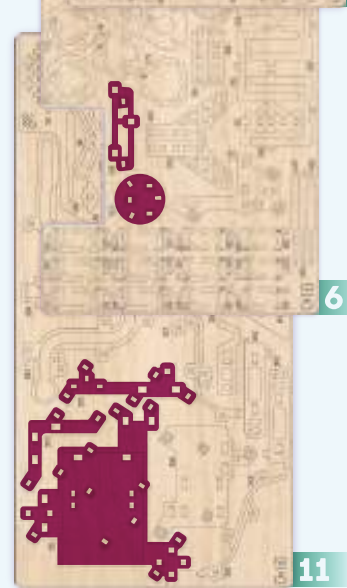

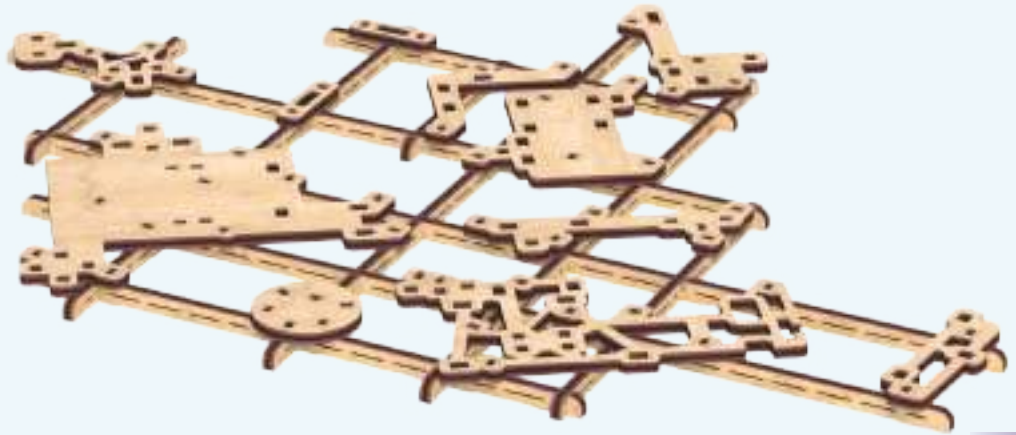
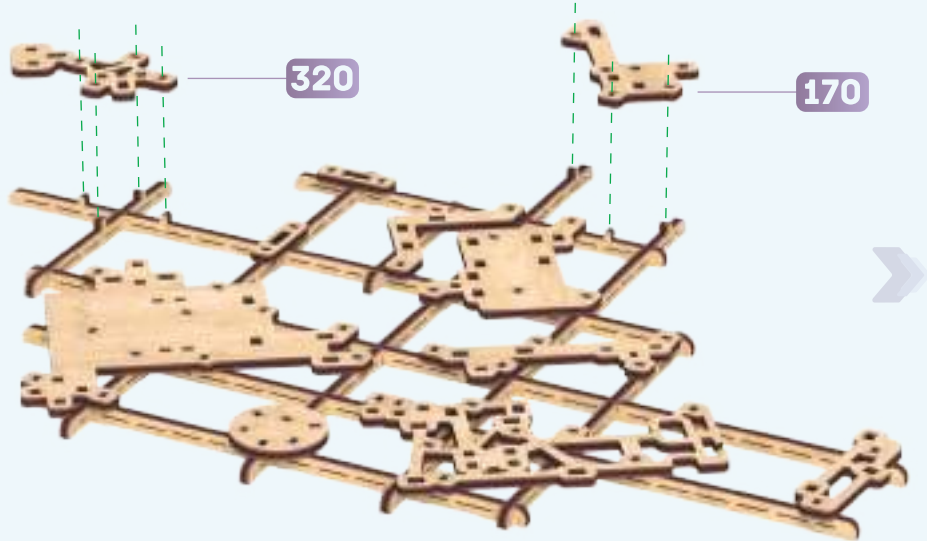
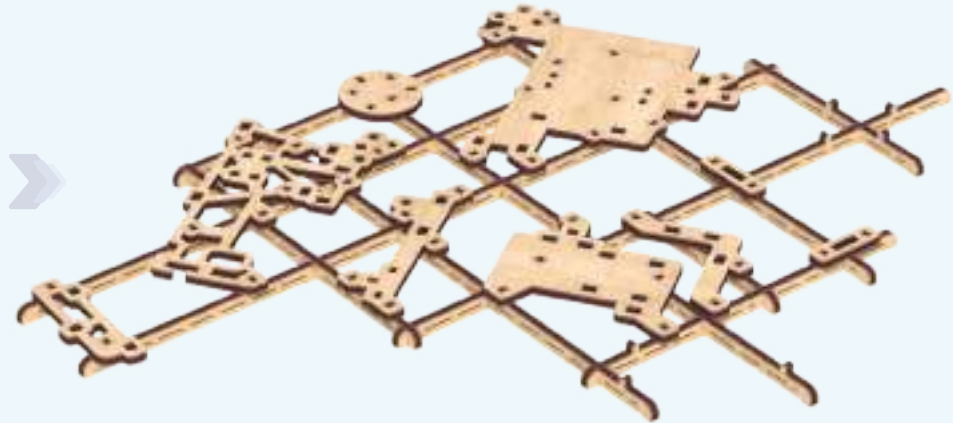
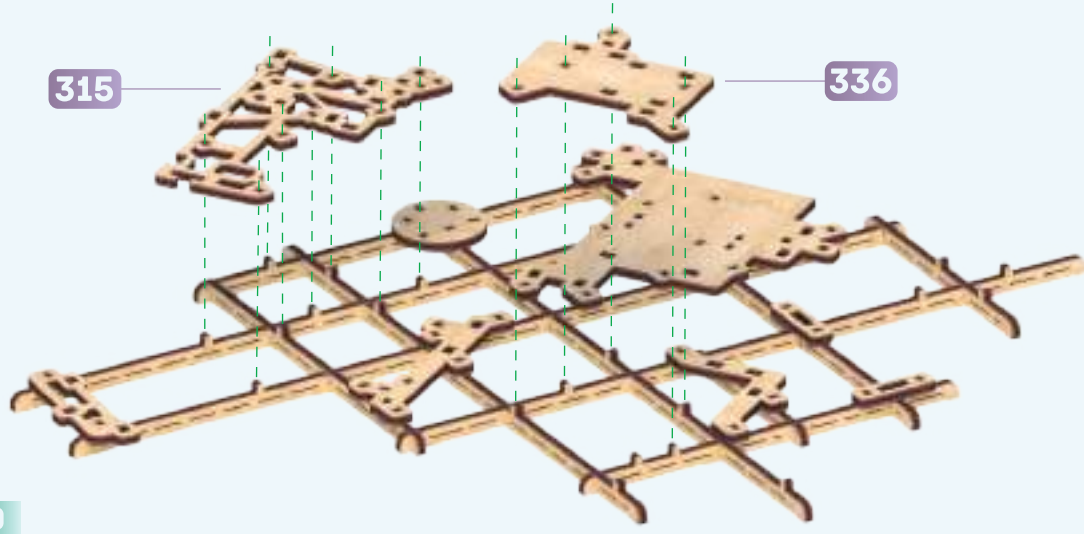
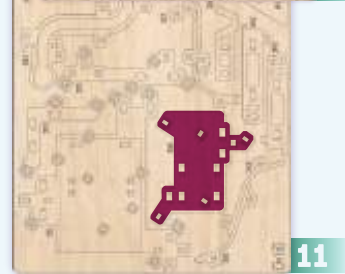
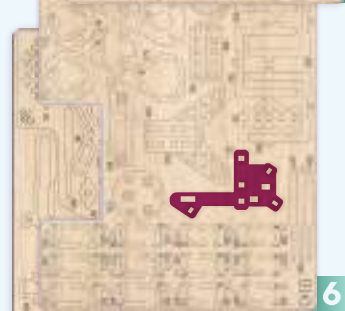

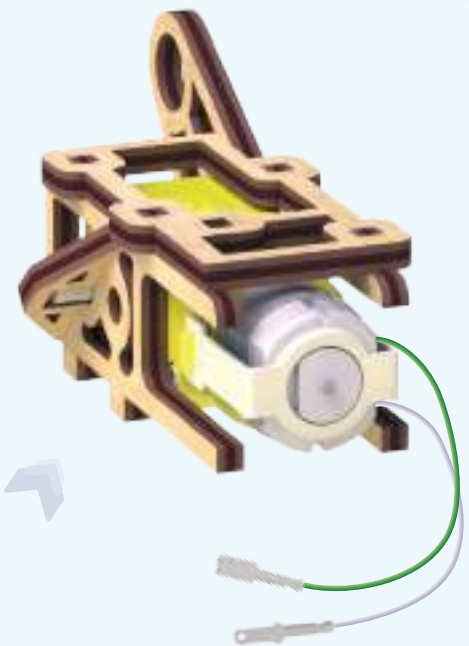
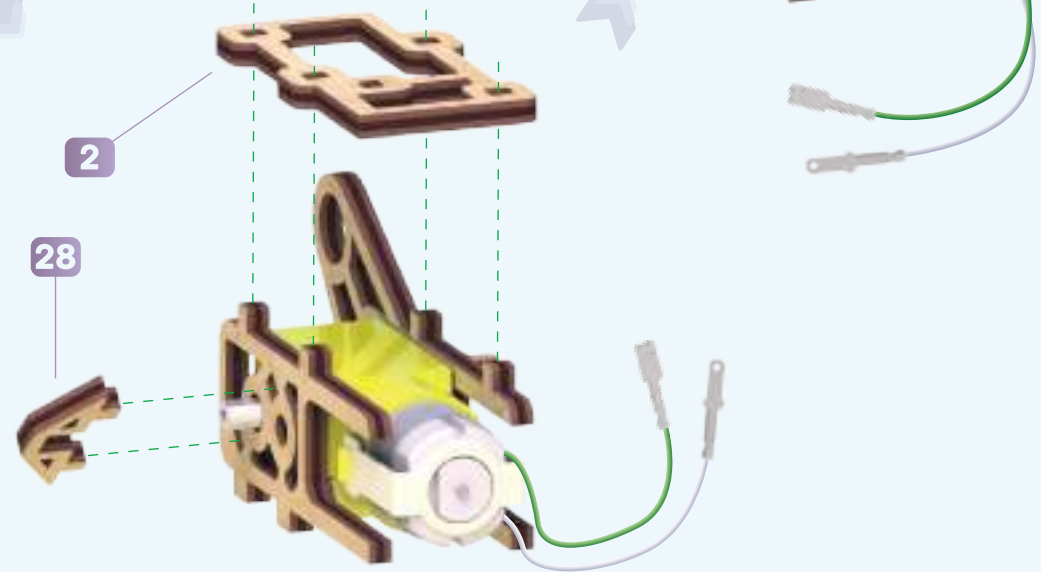
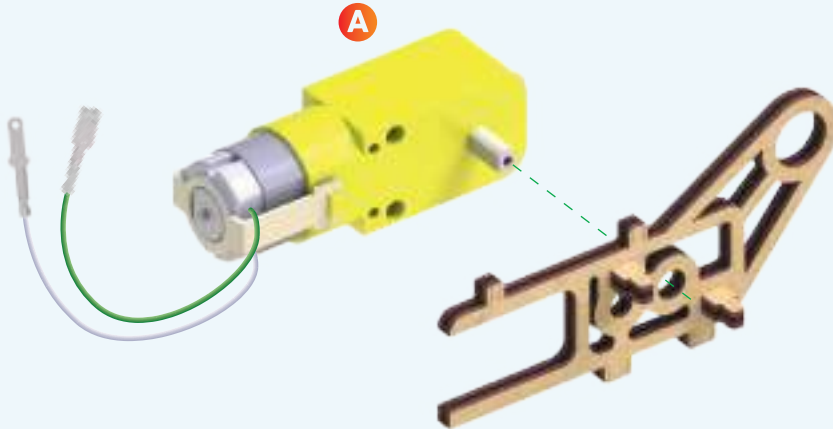
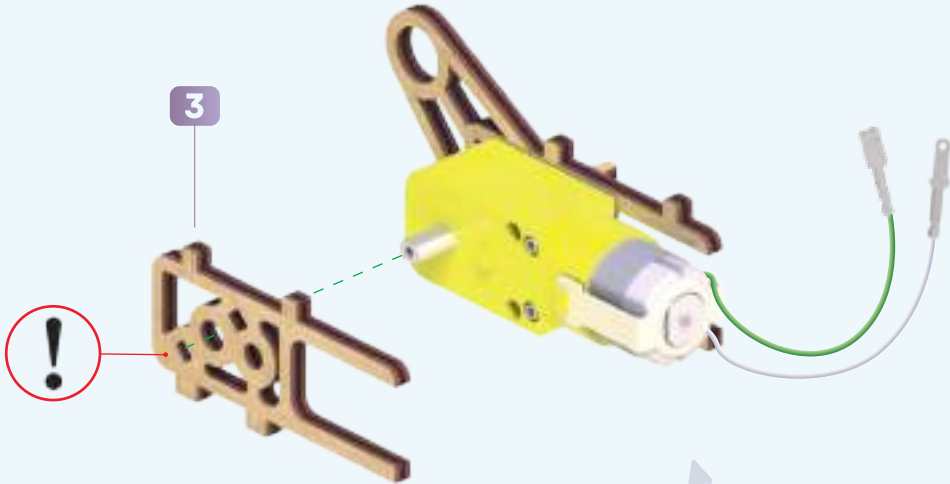
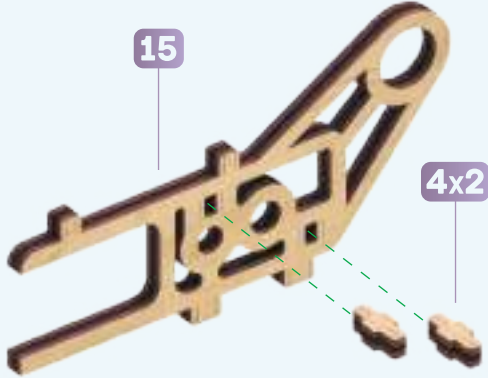
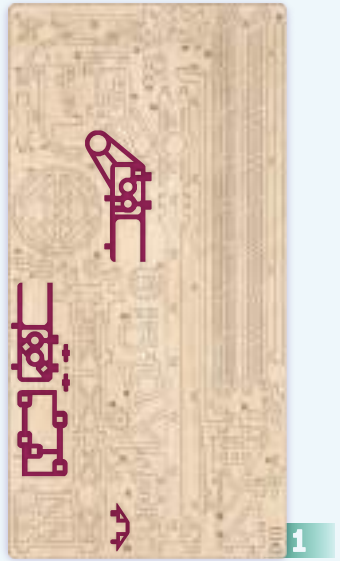

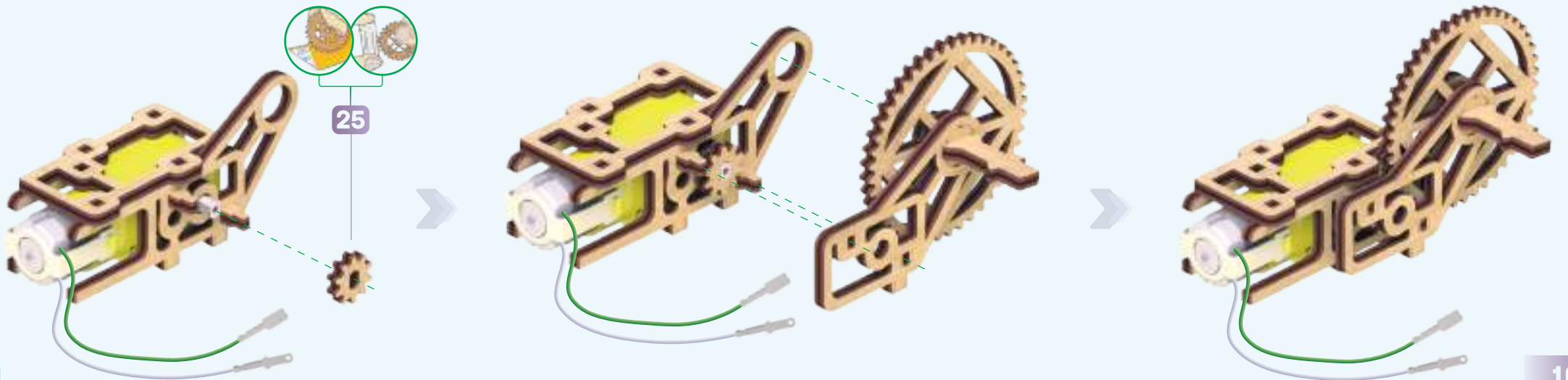
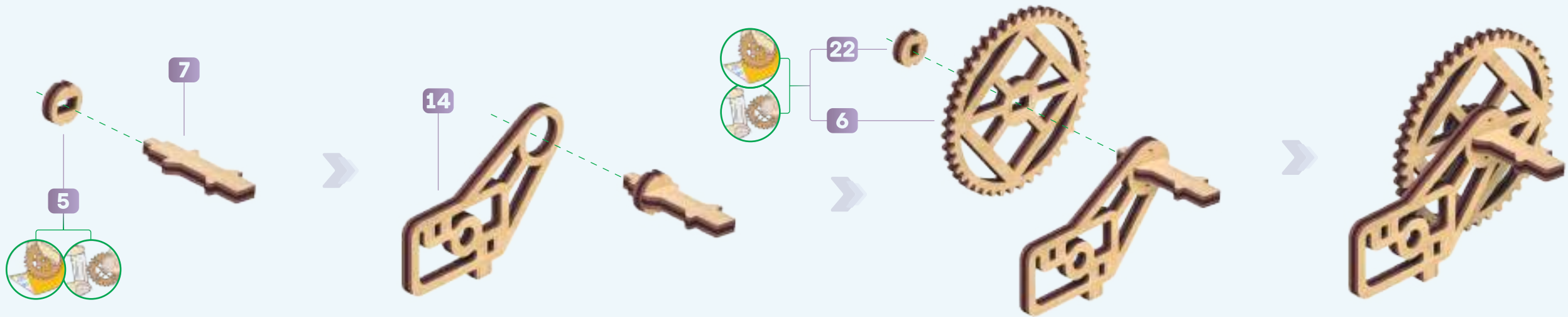

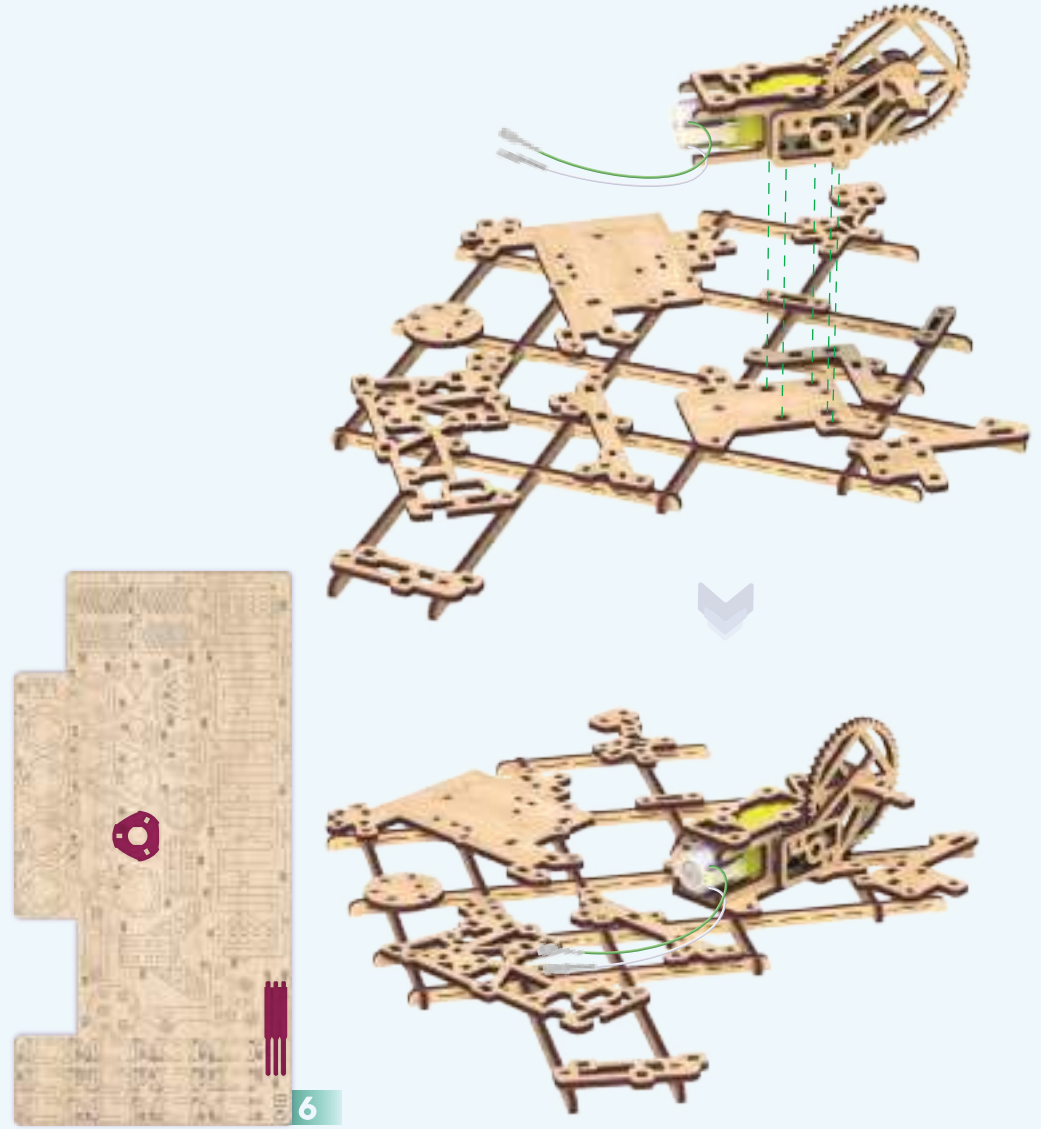

6



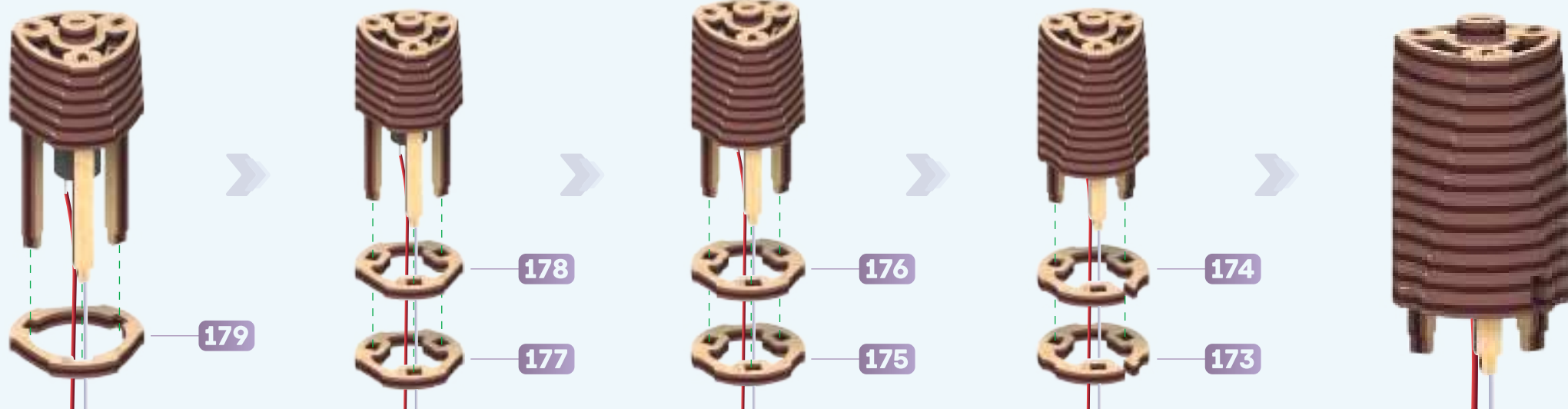
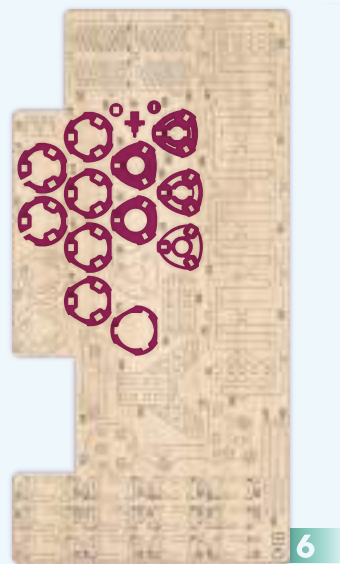
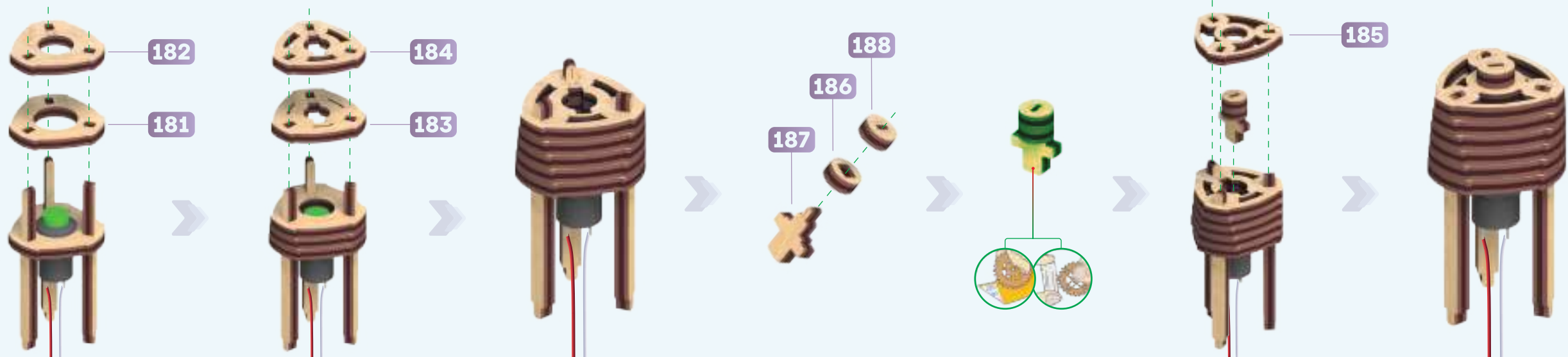

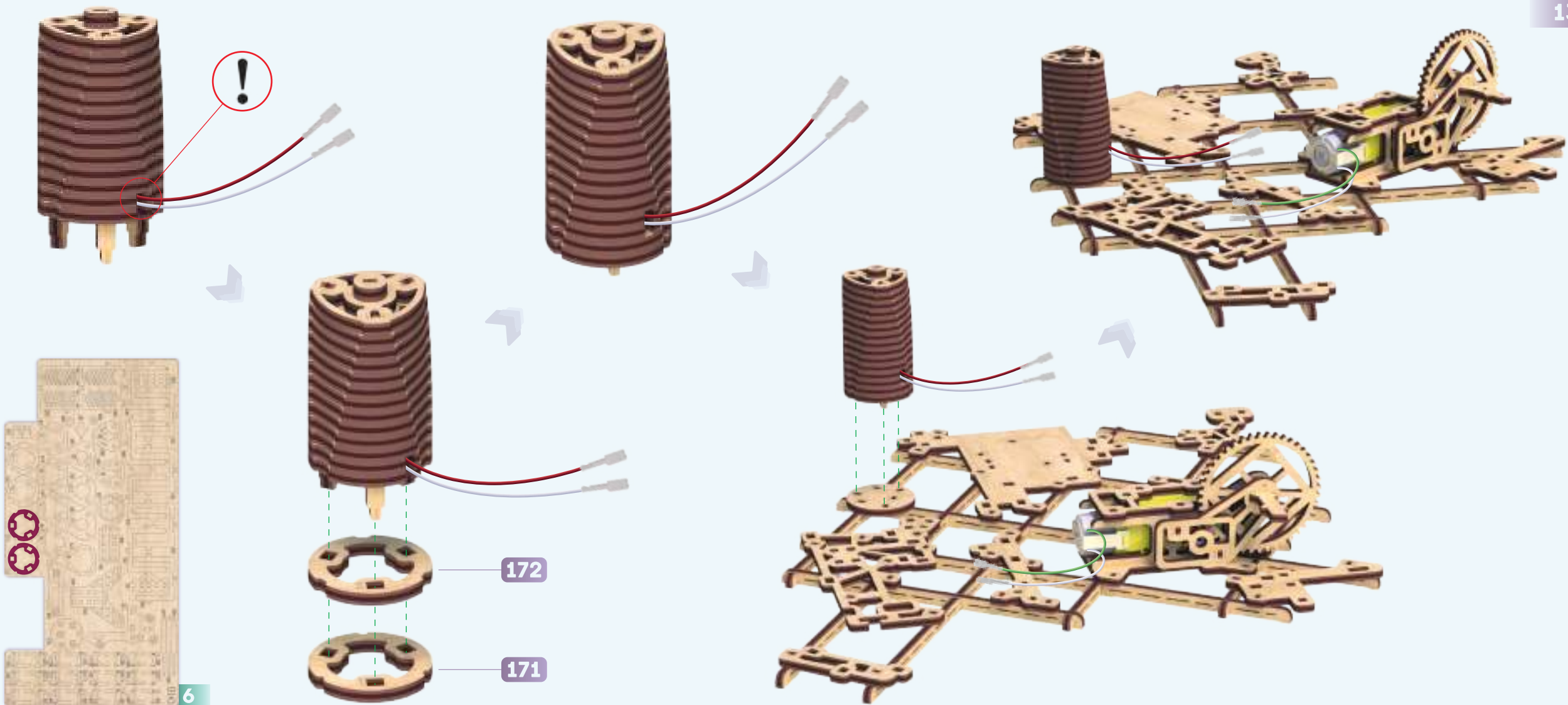

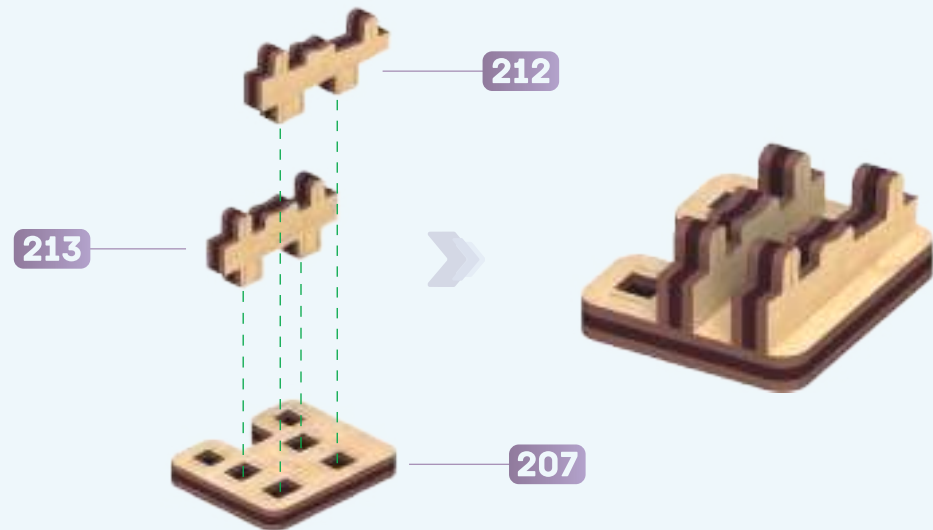
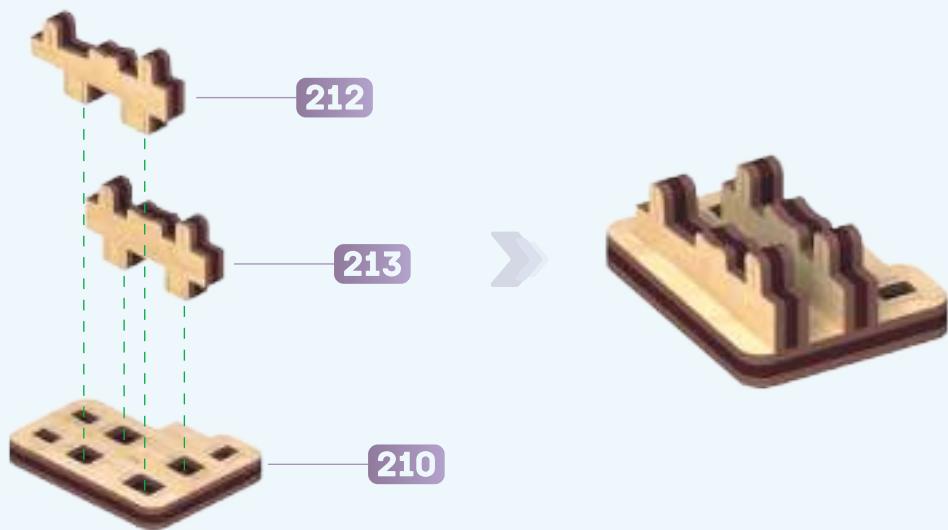
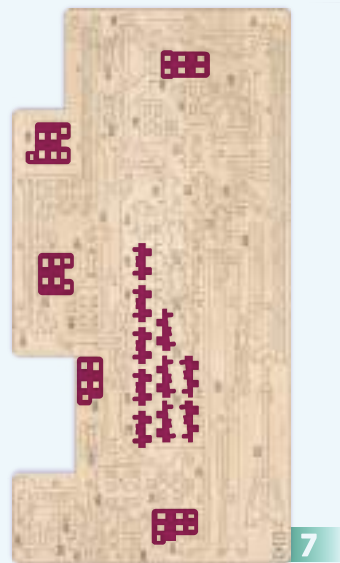
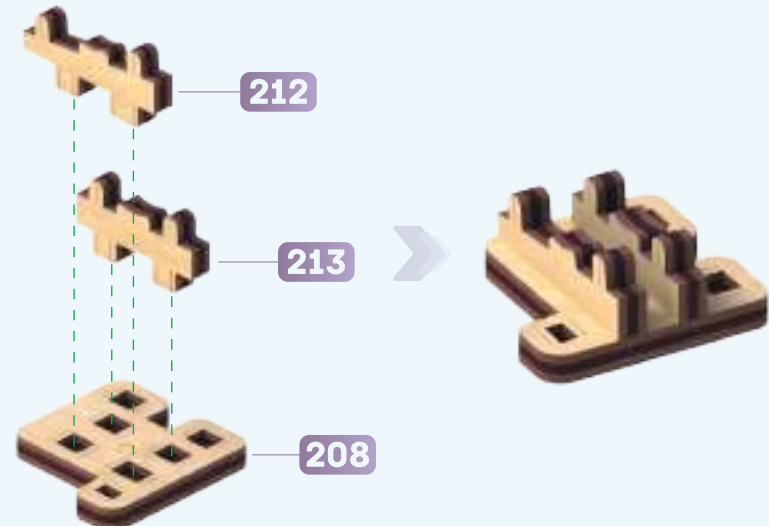
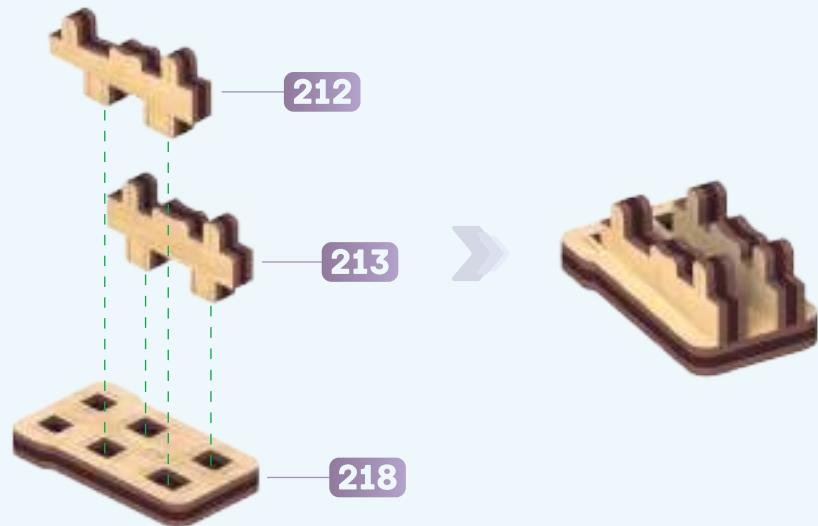
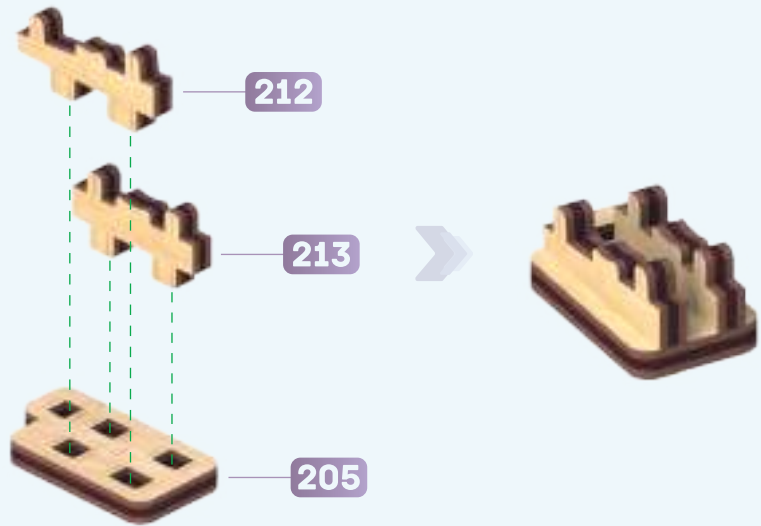

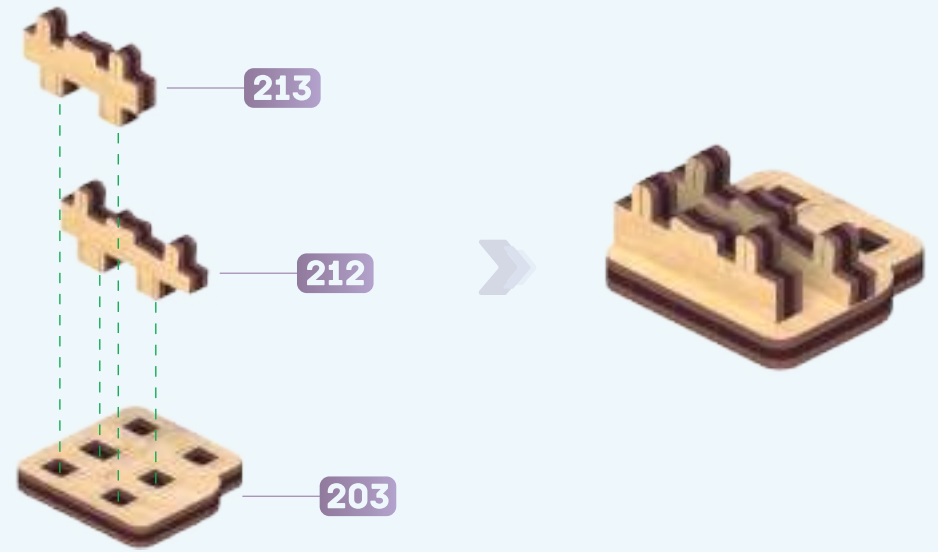
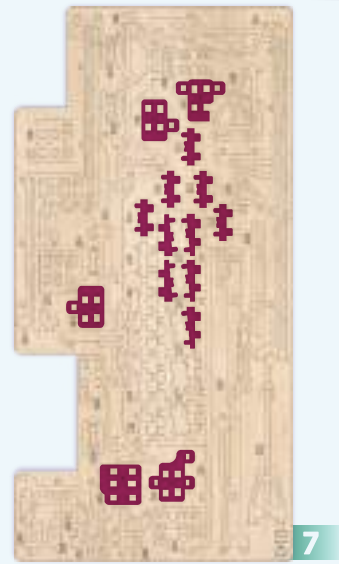
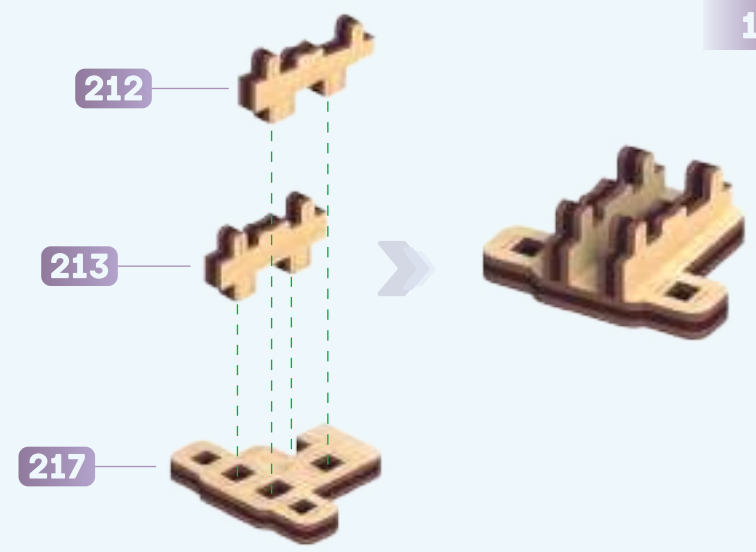
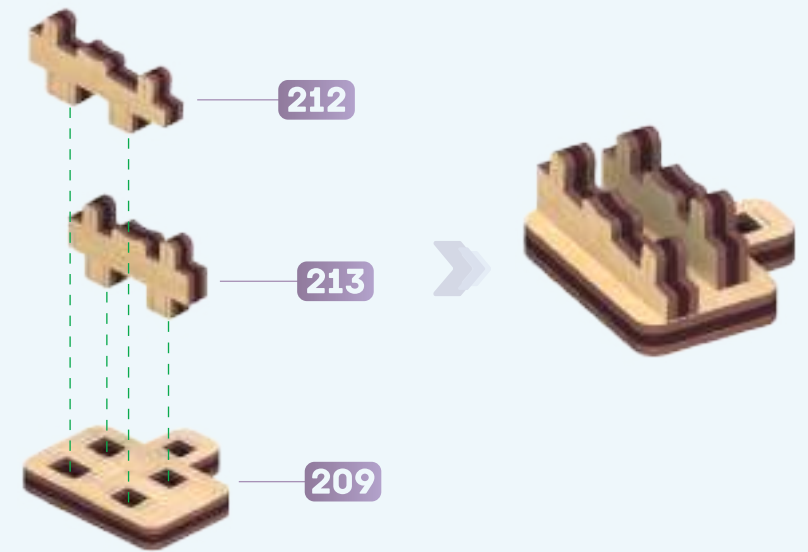
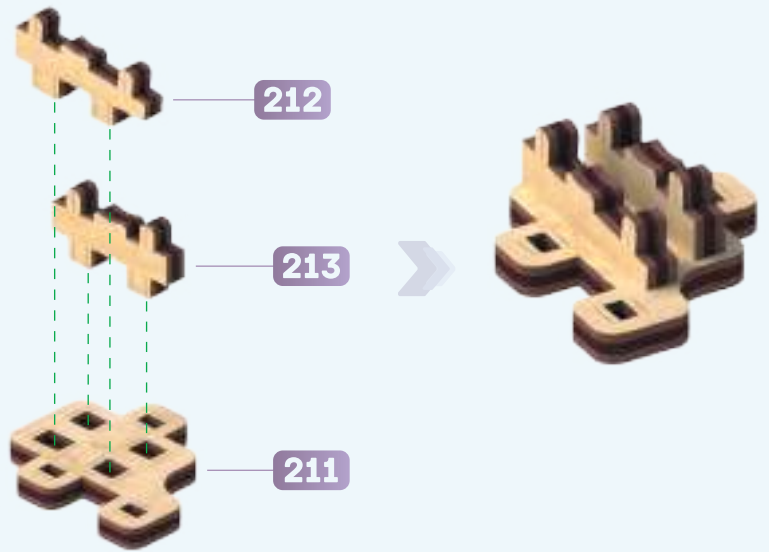

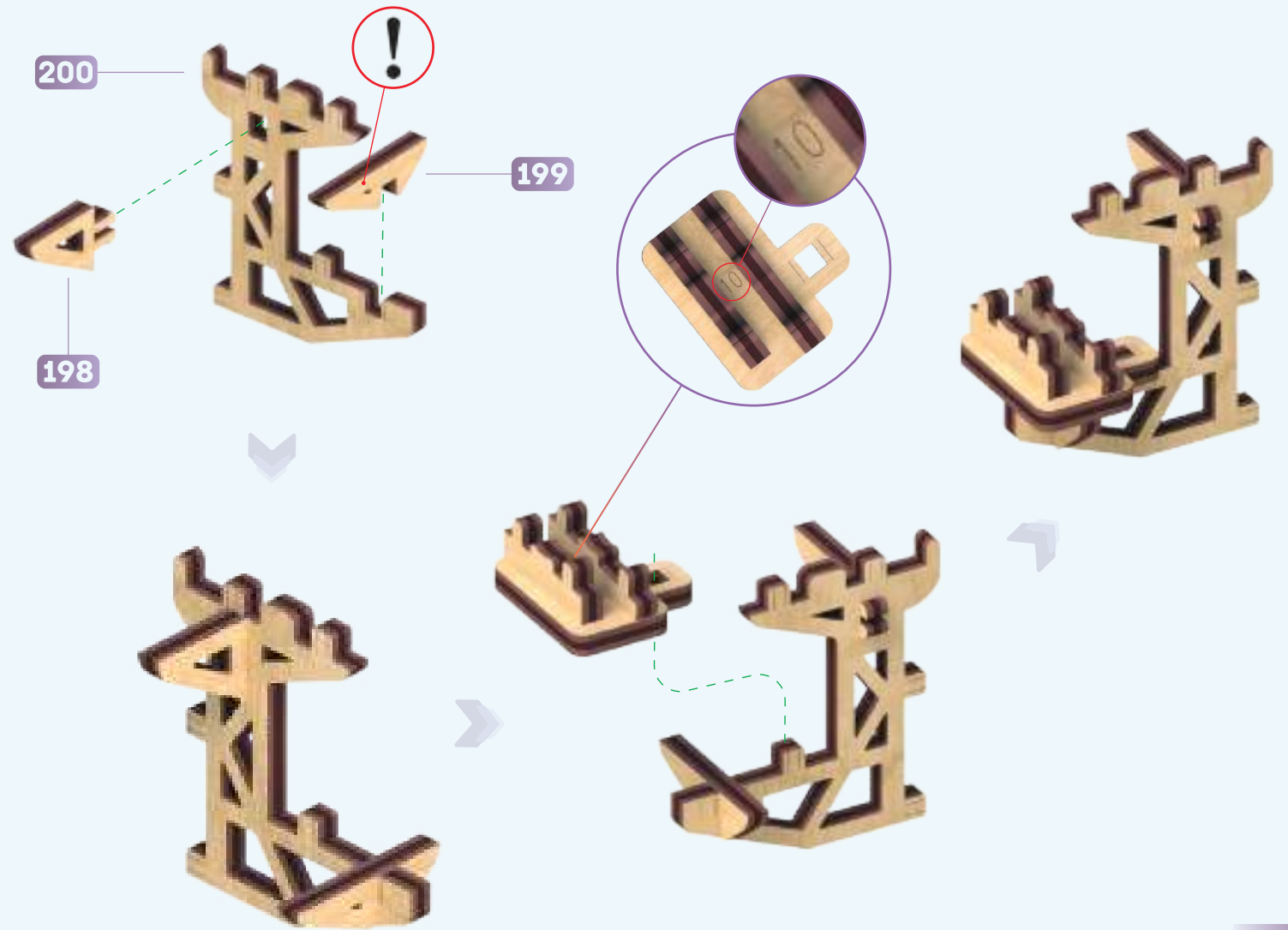
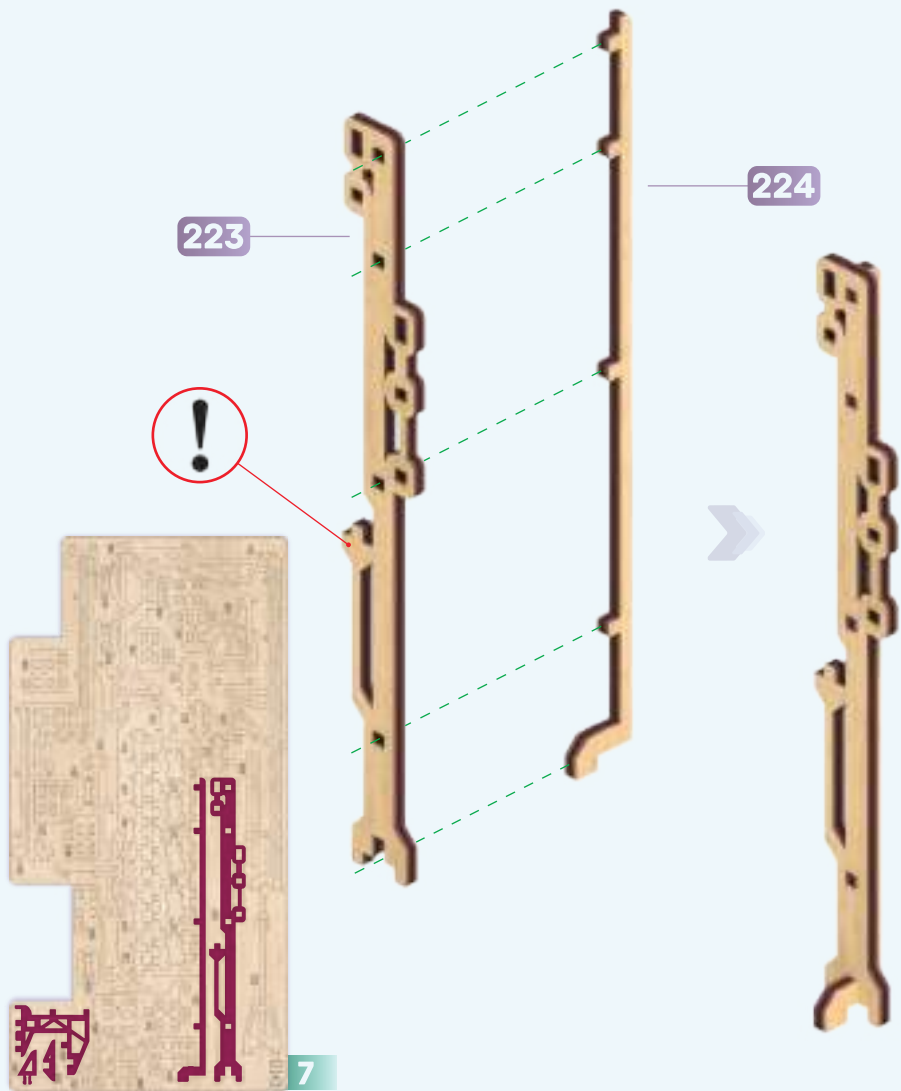

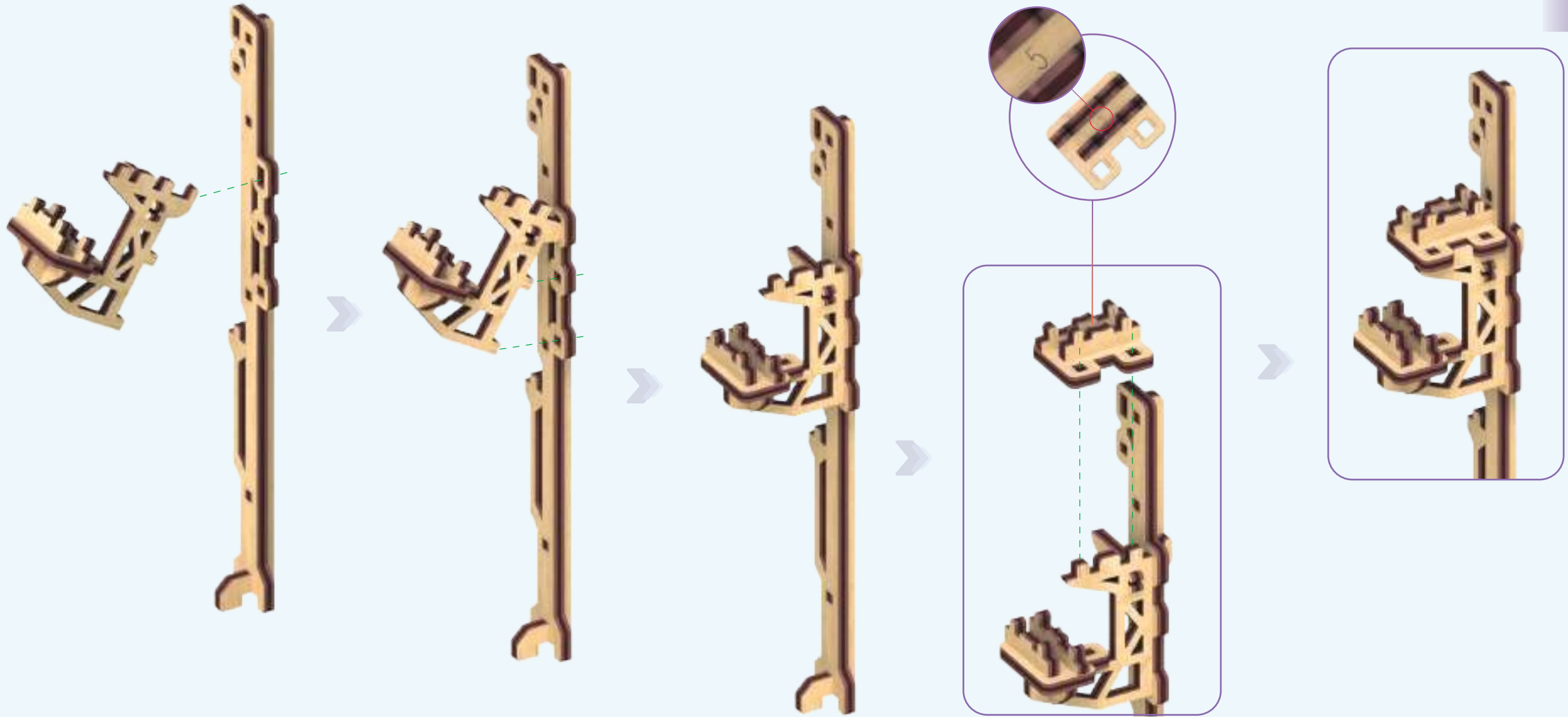

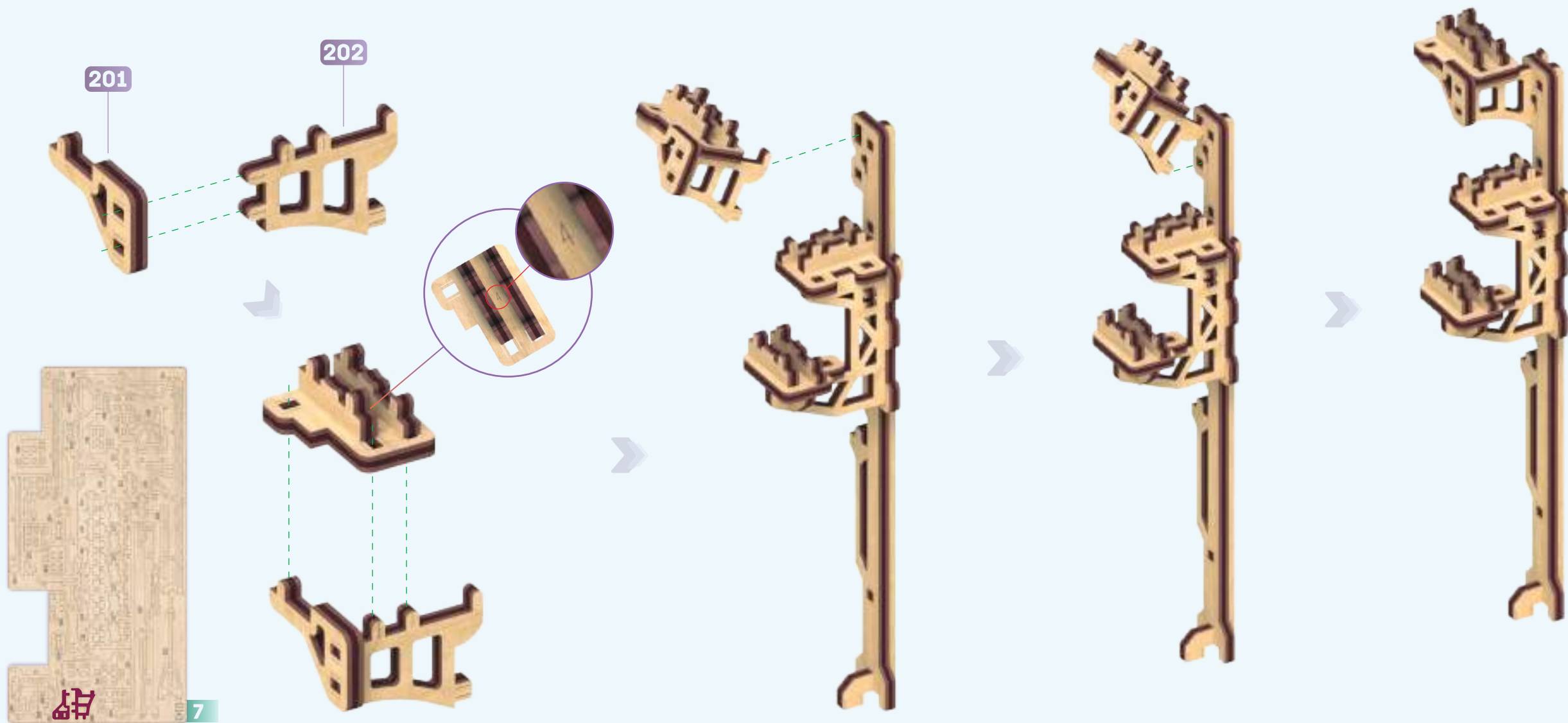

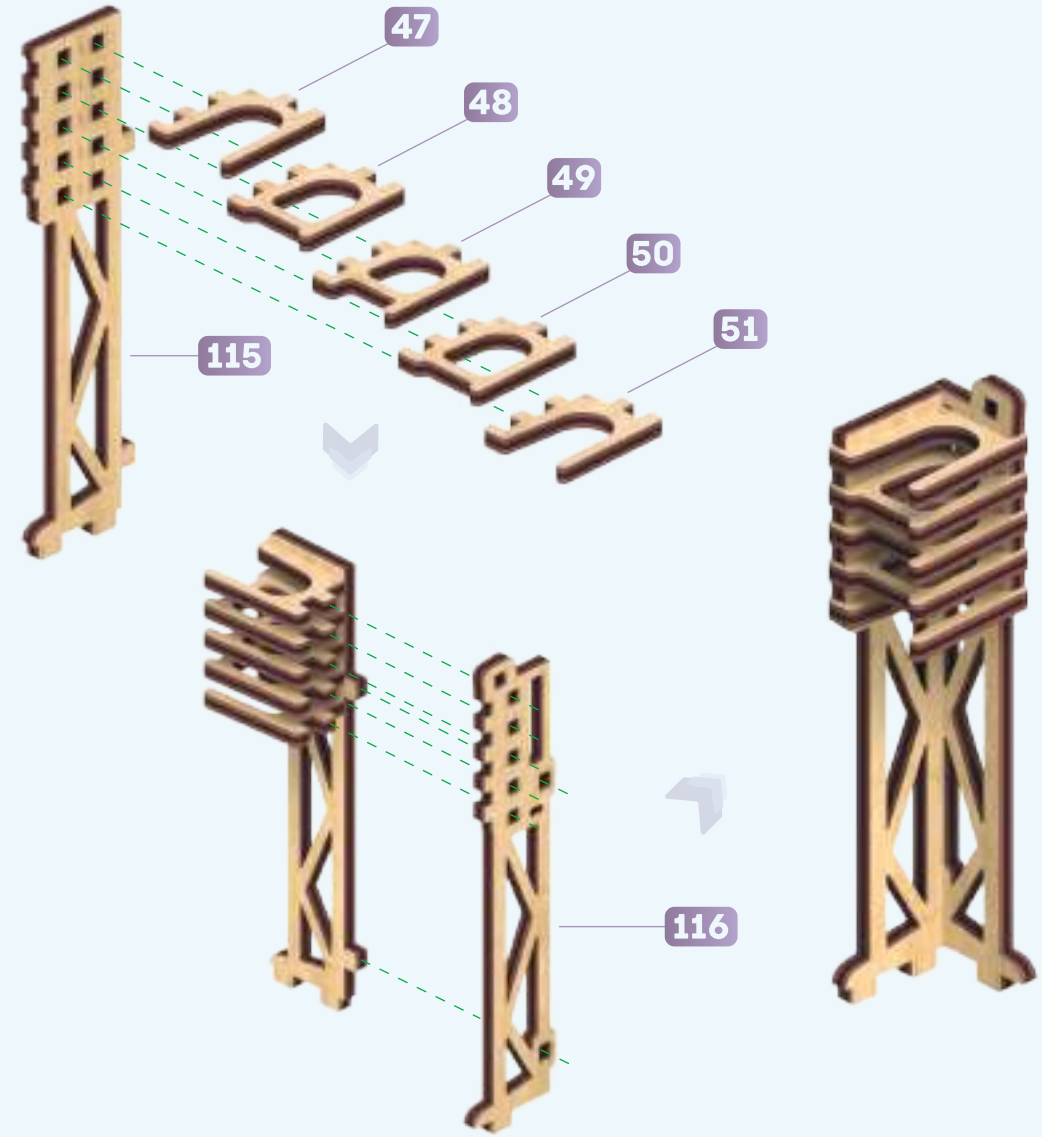
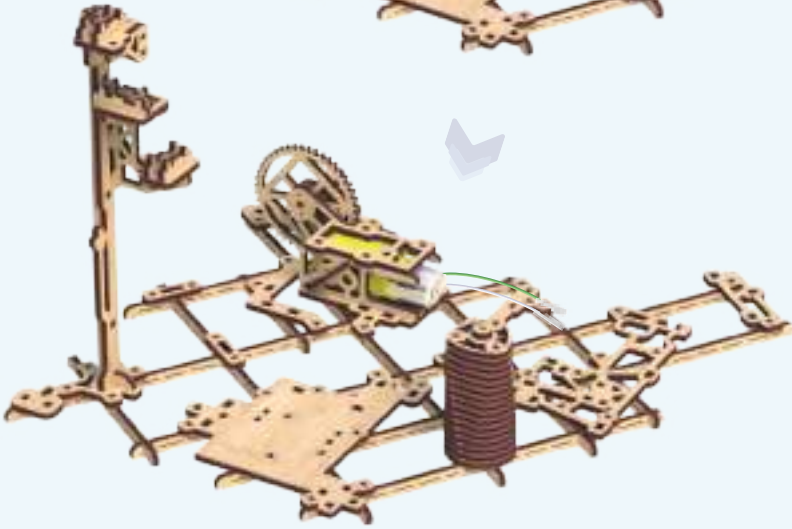
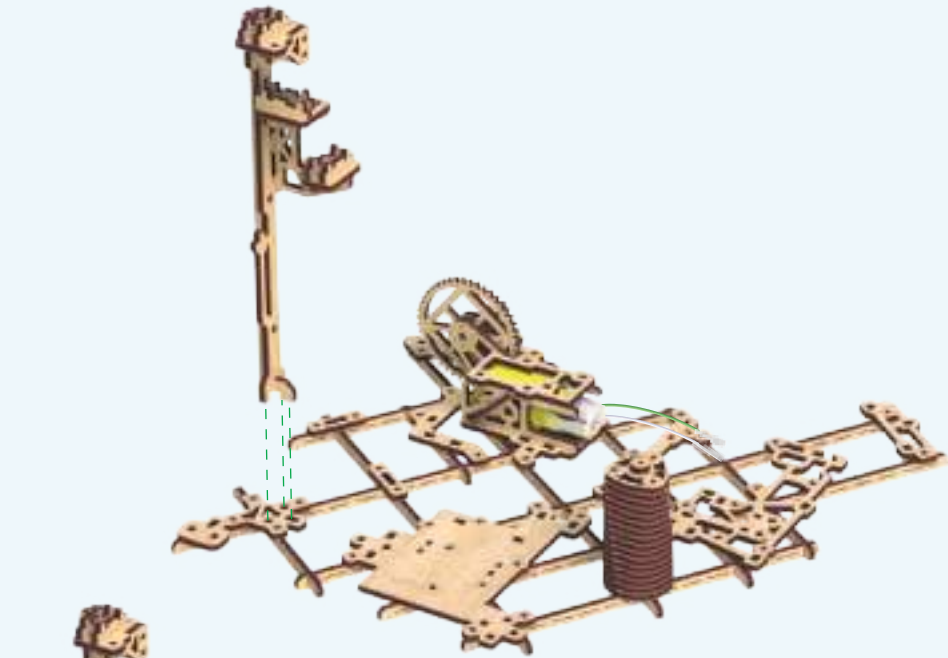
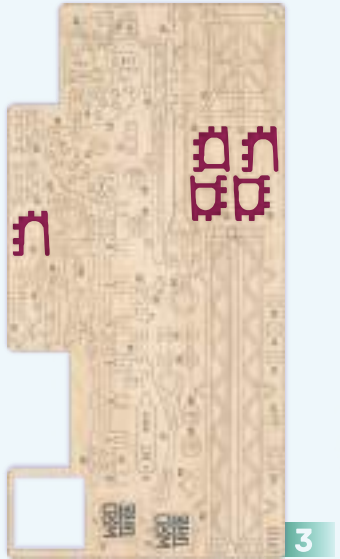

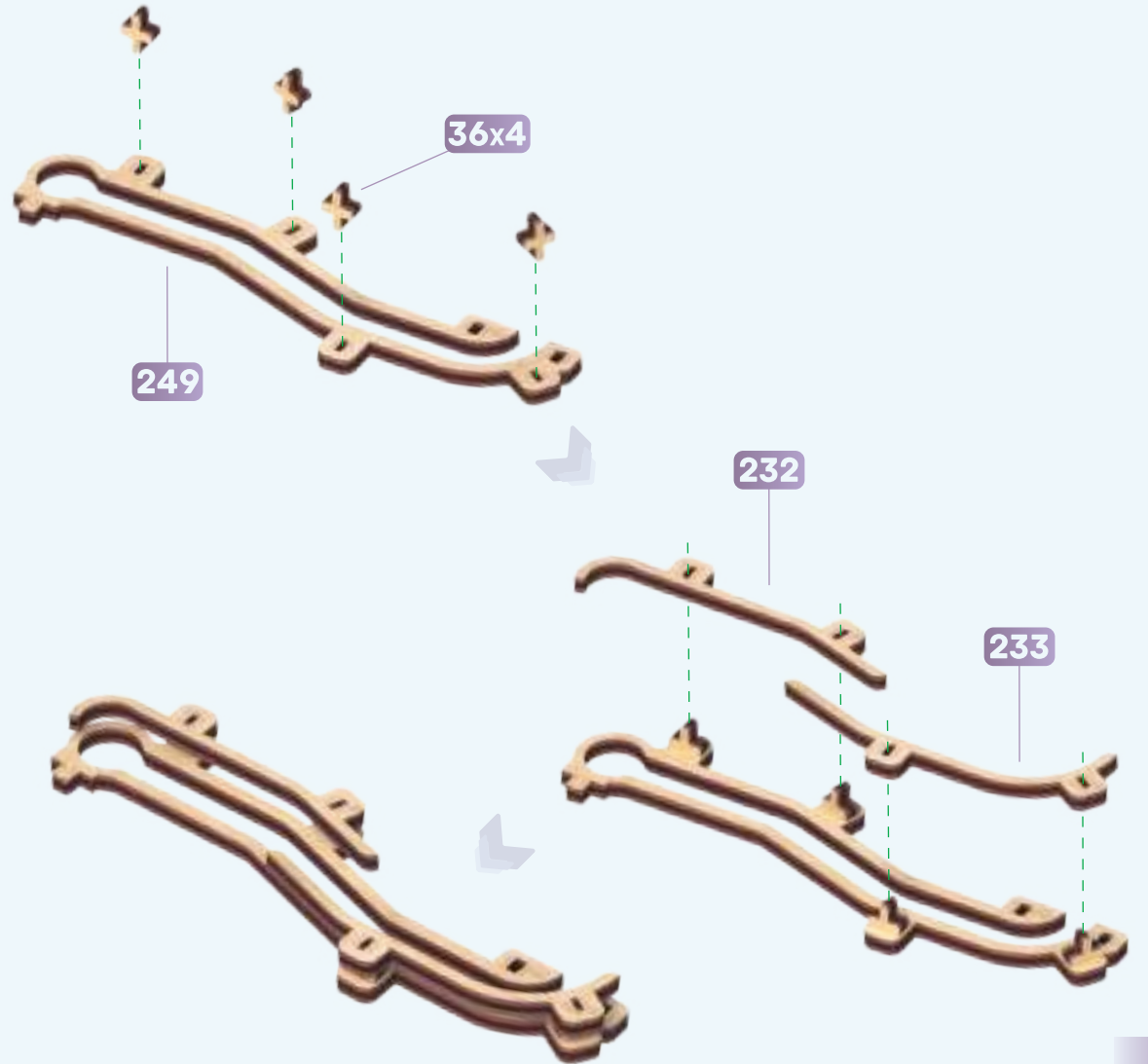
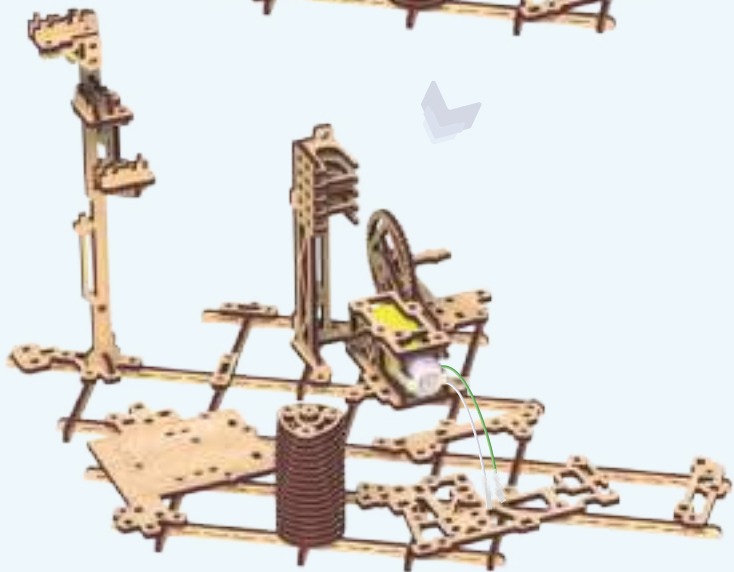
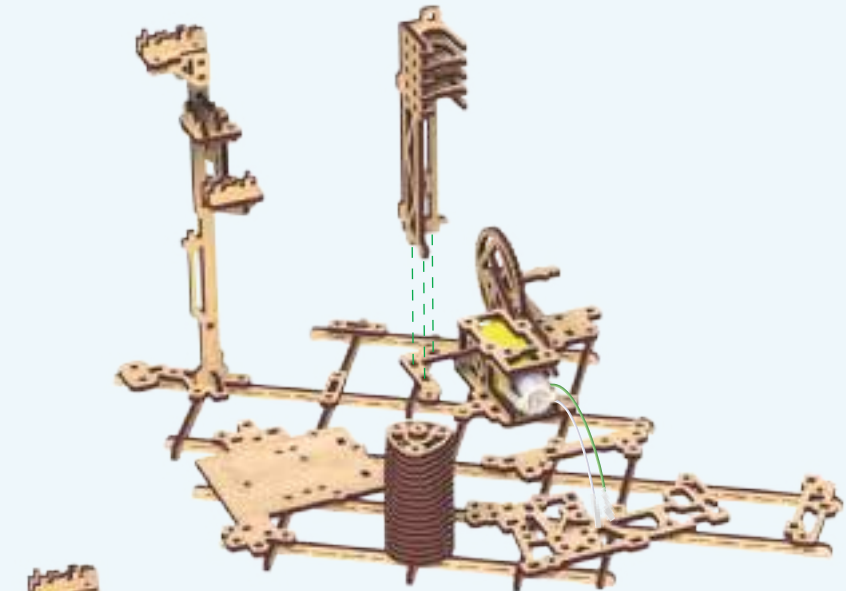
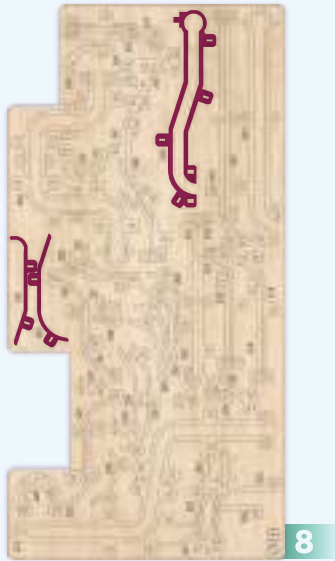

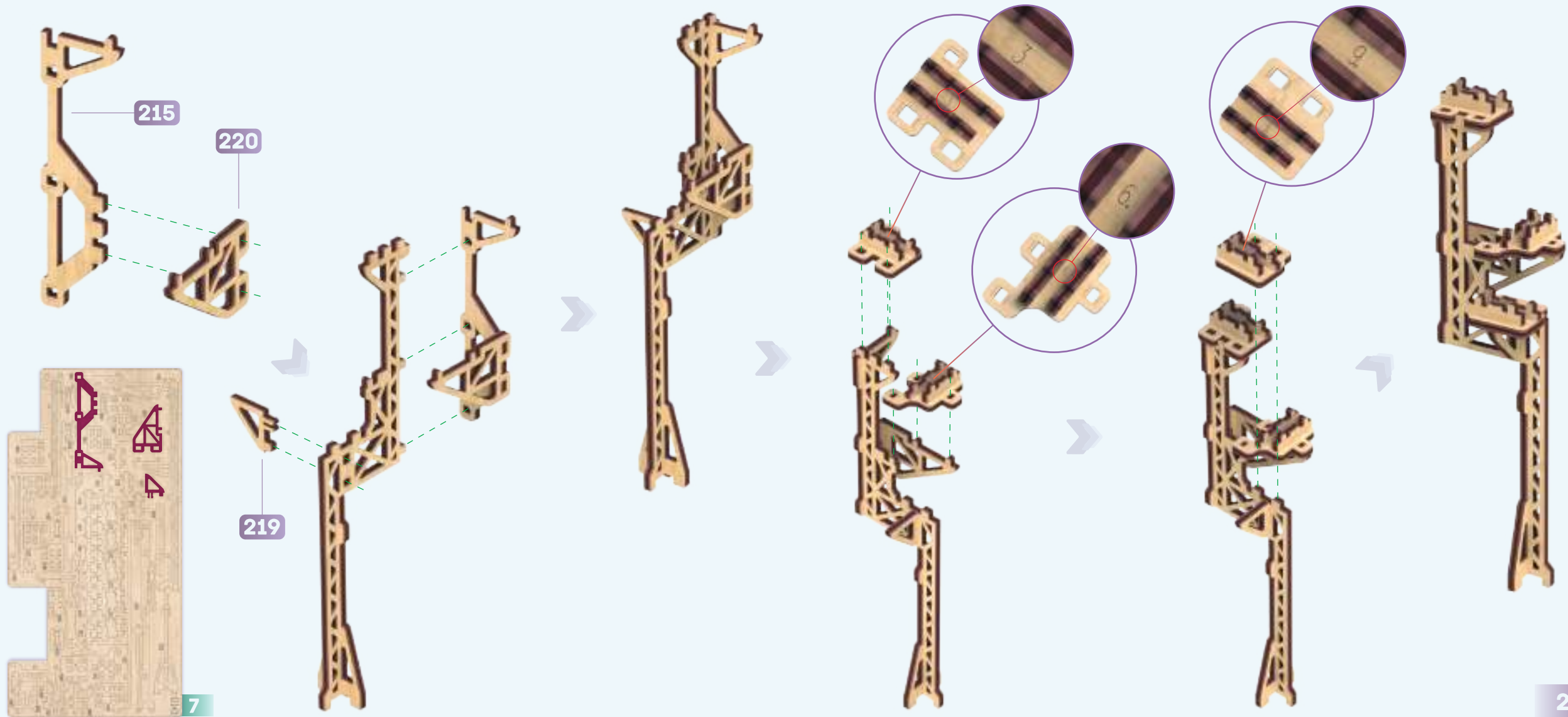

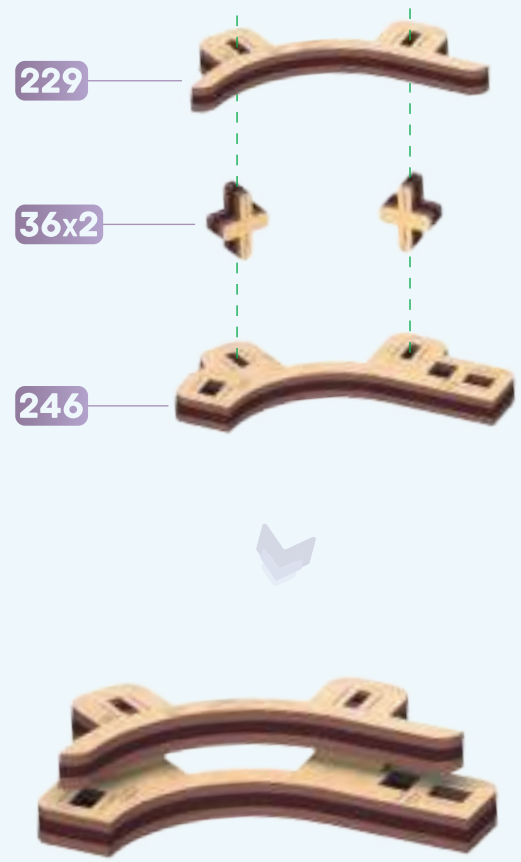
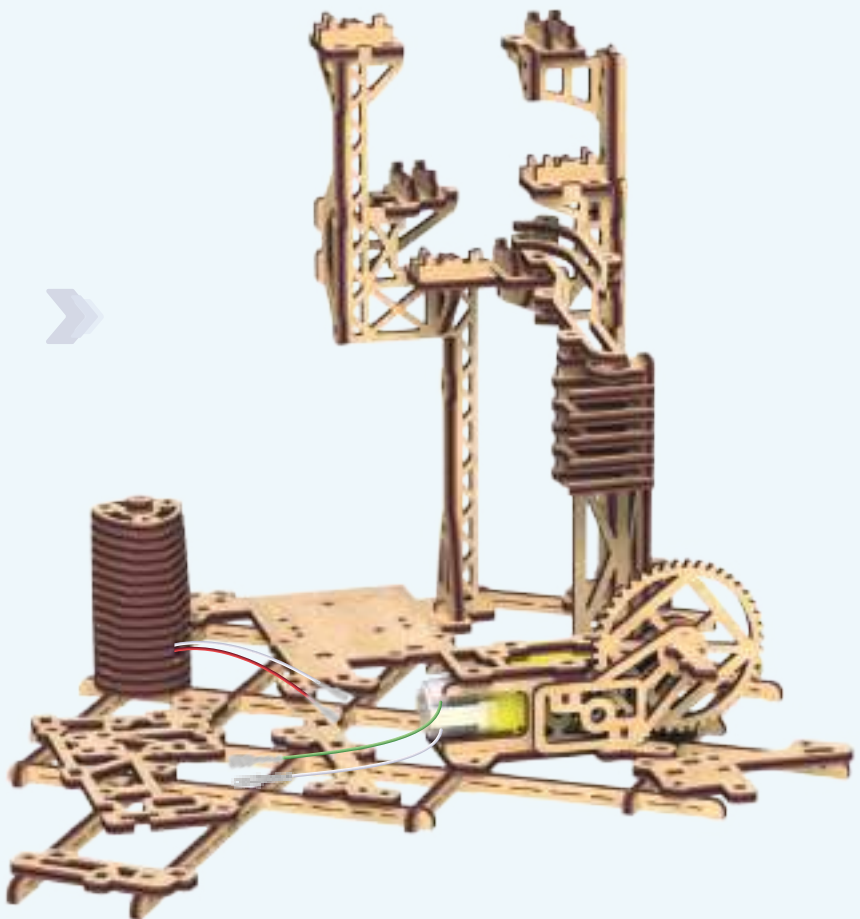
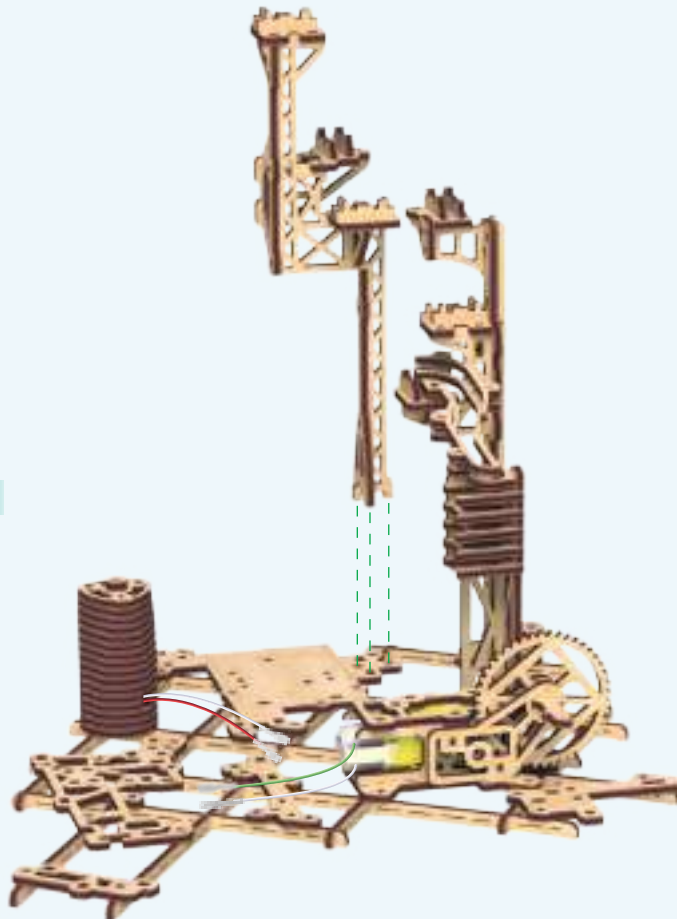



8

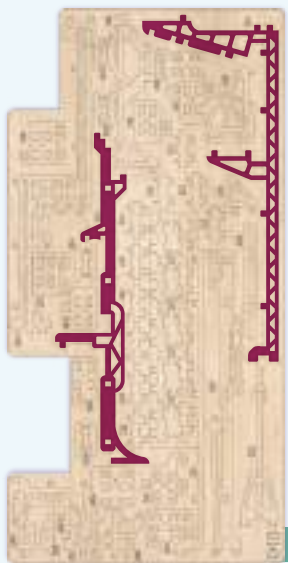
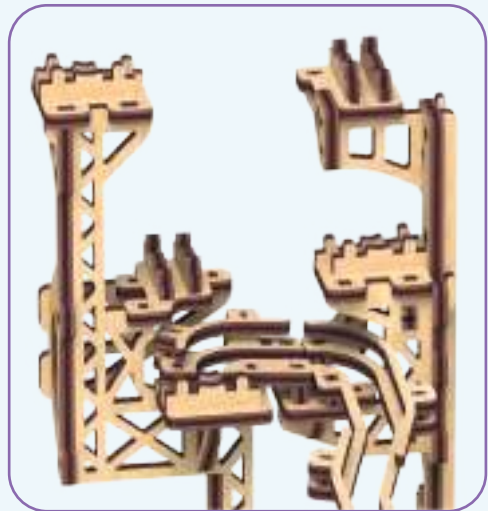
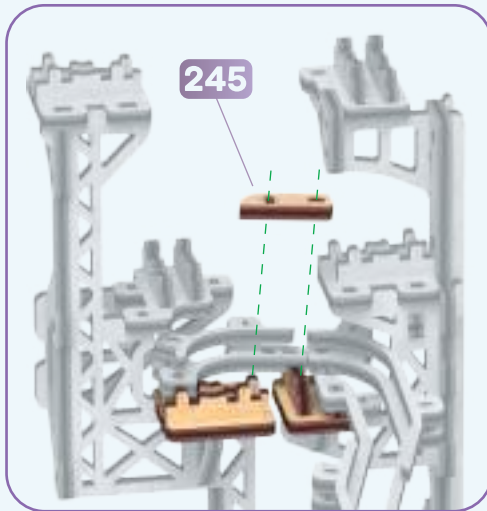
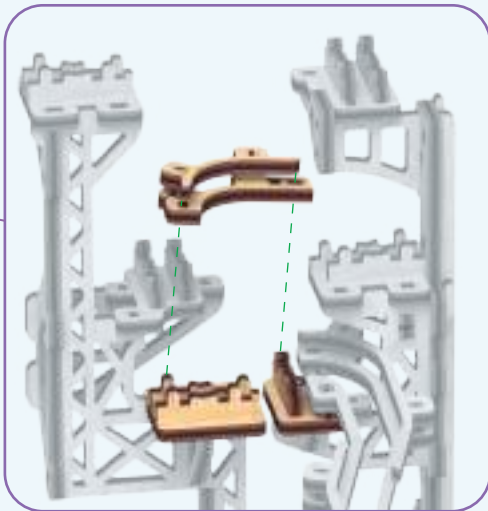
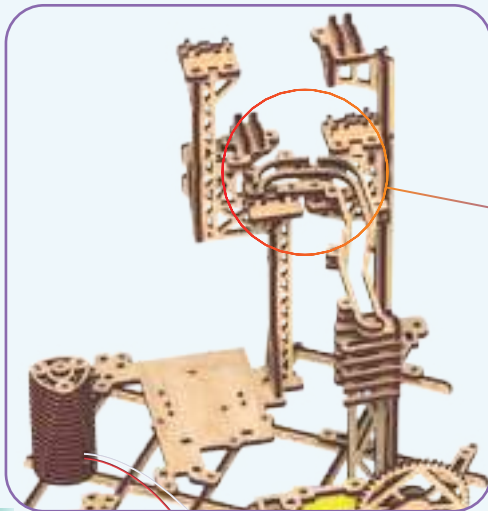

7

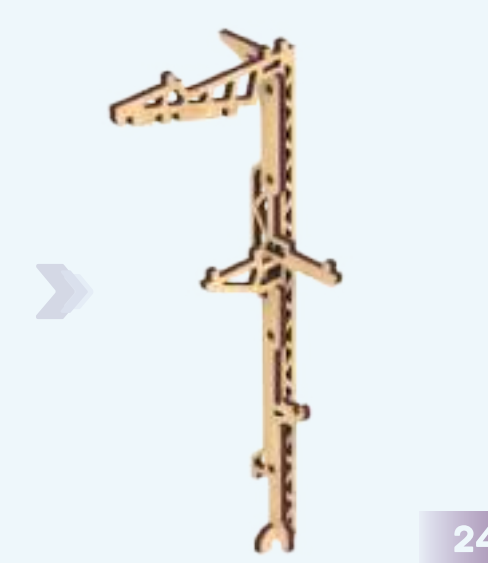
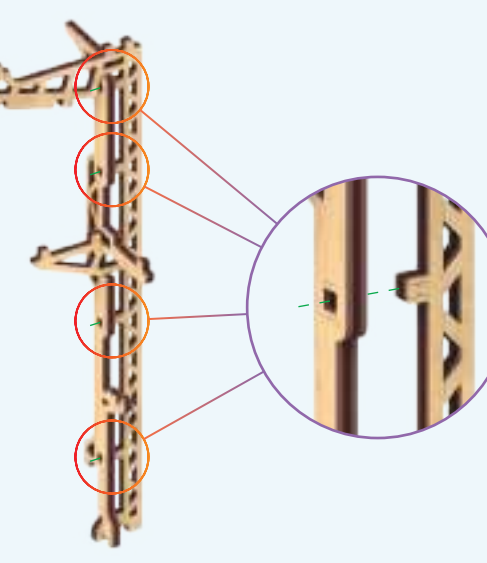
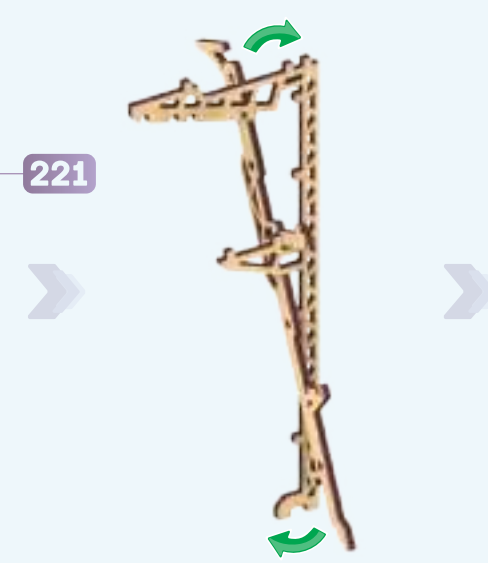
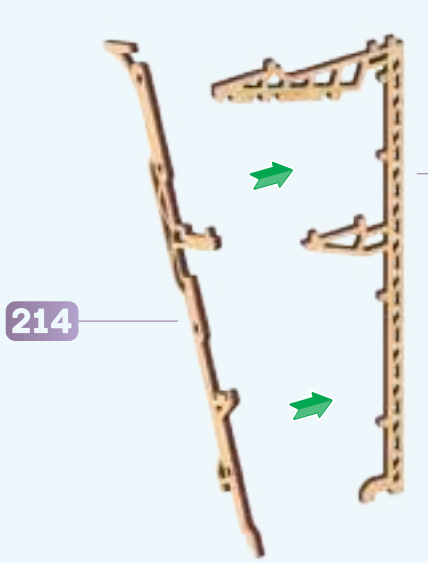

222

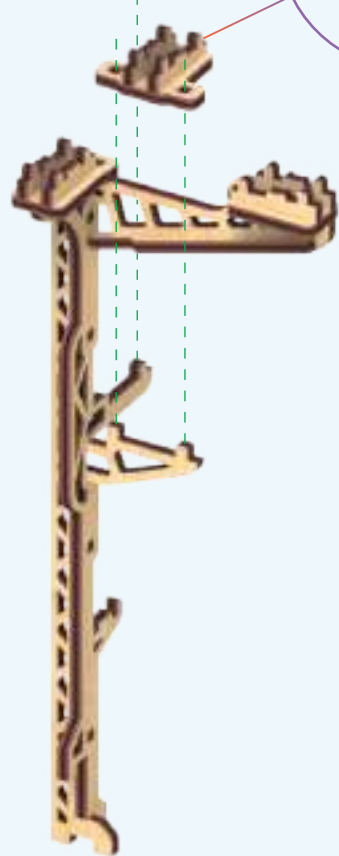
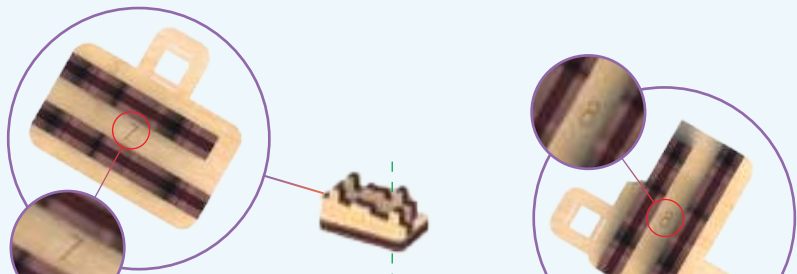
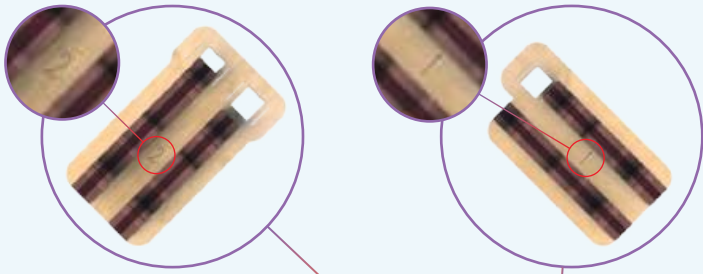
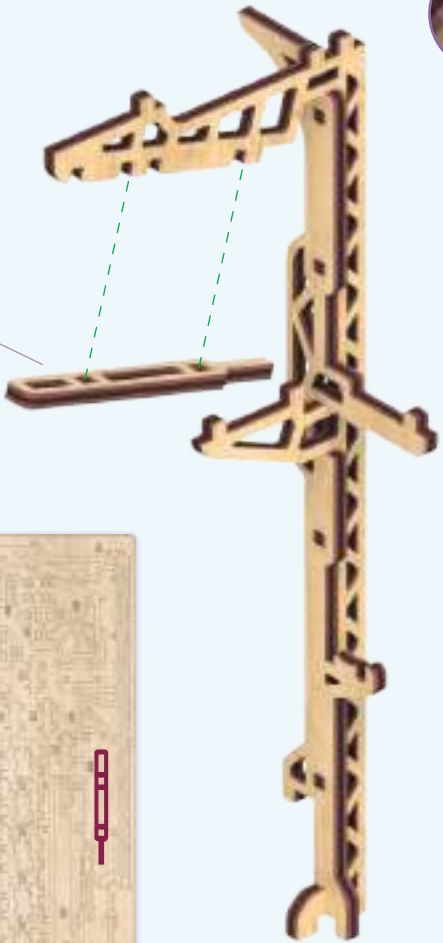

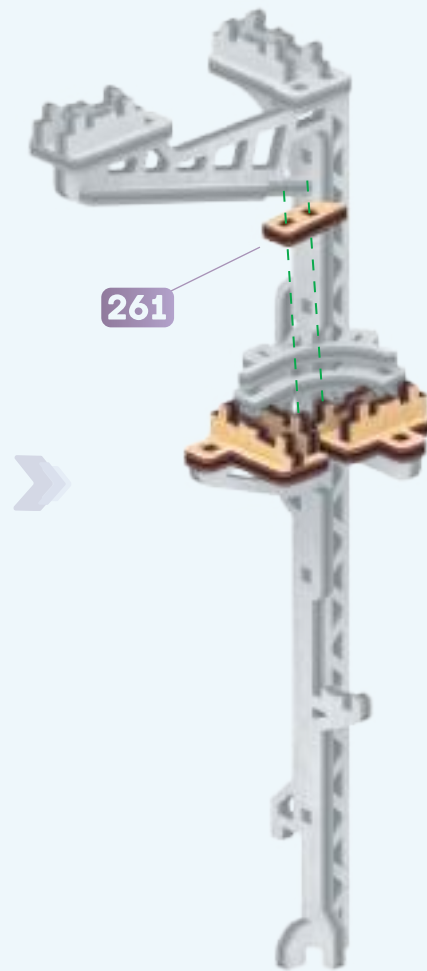
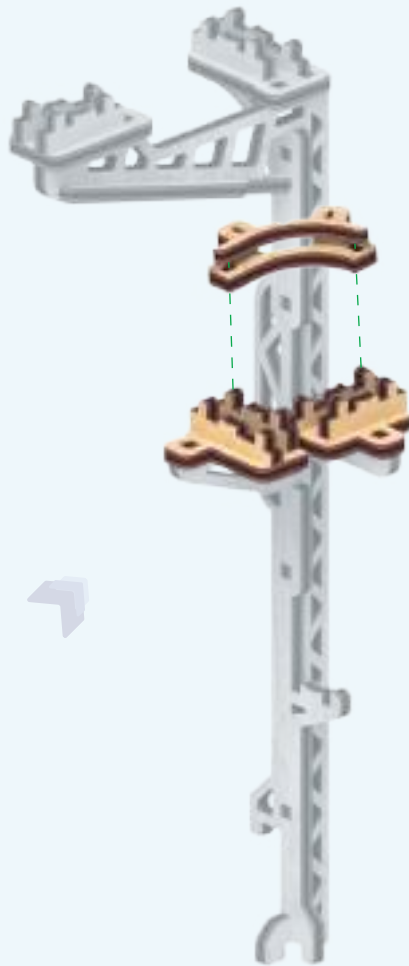
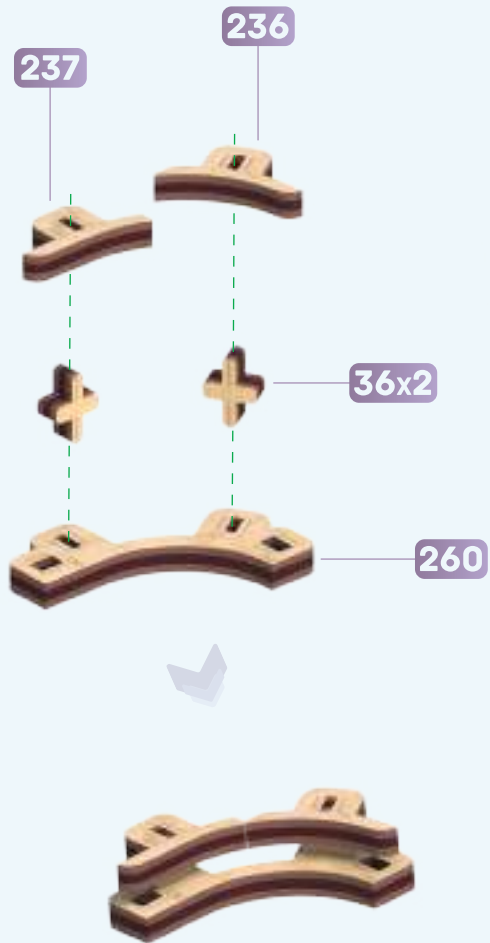
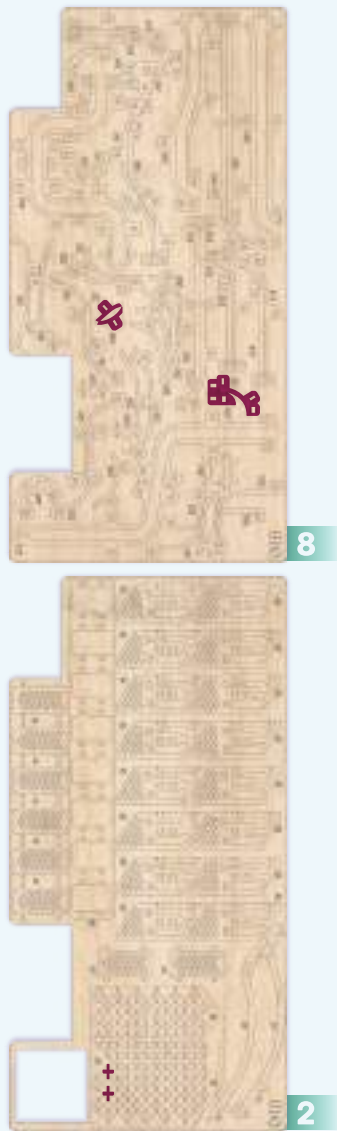

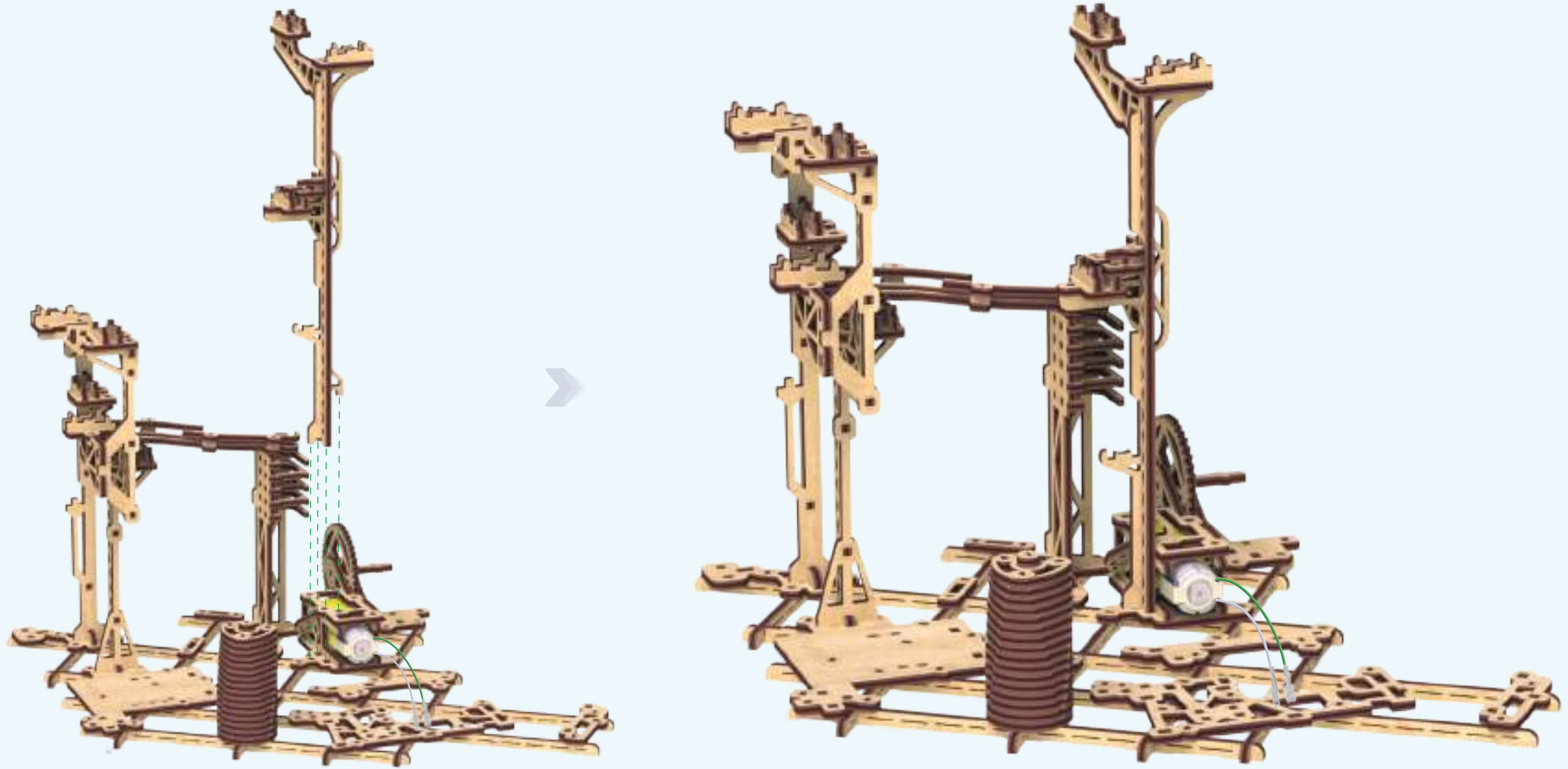

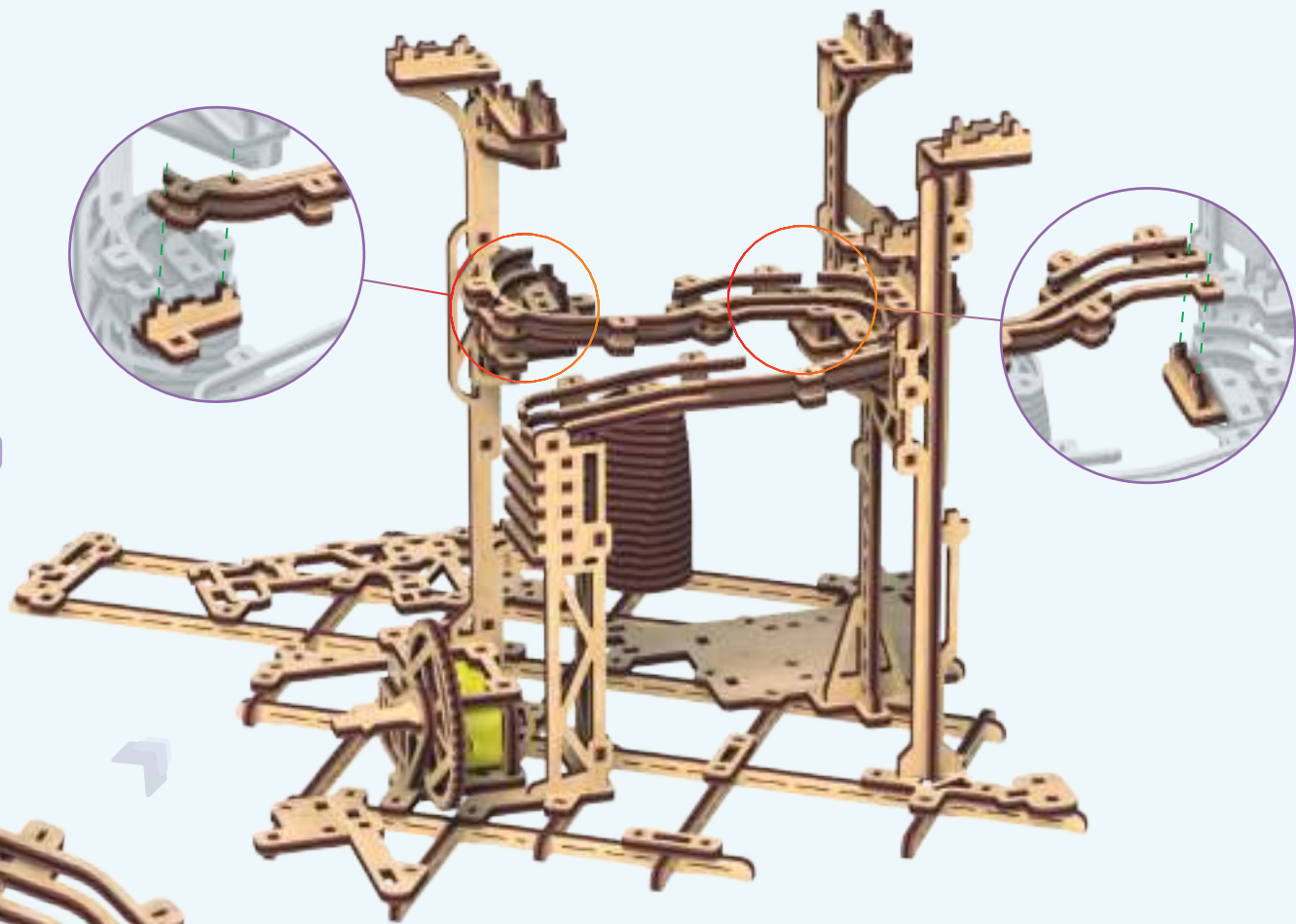
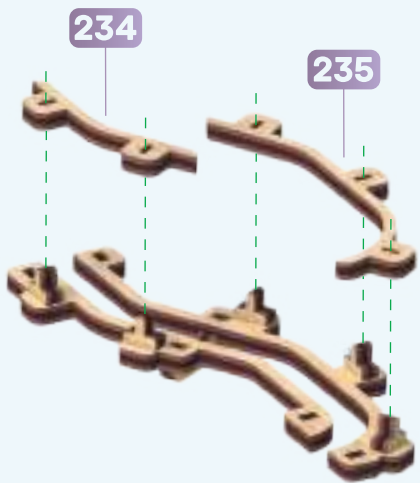
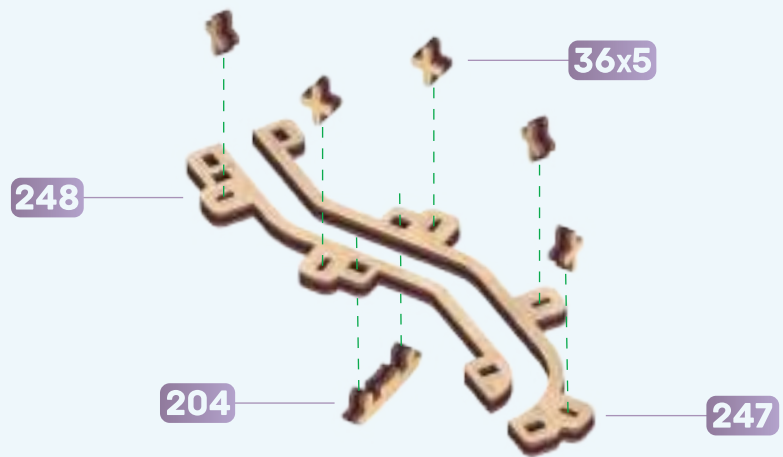
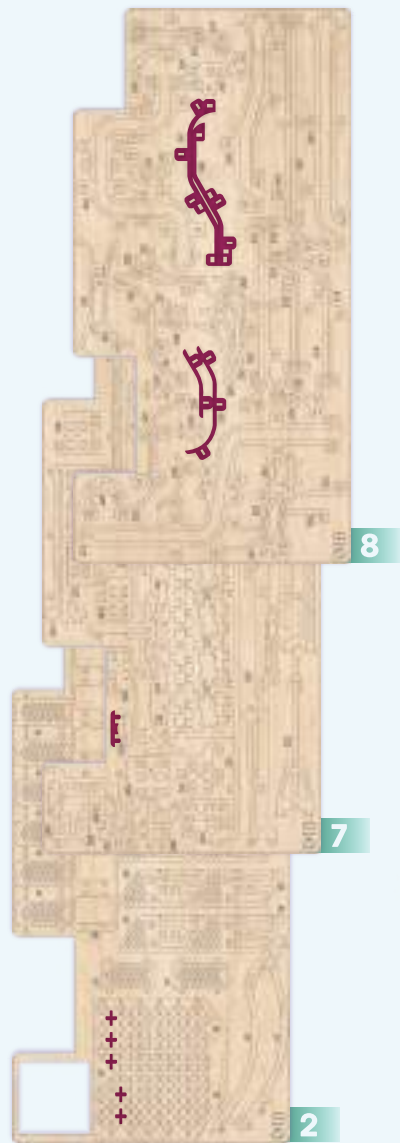

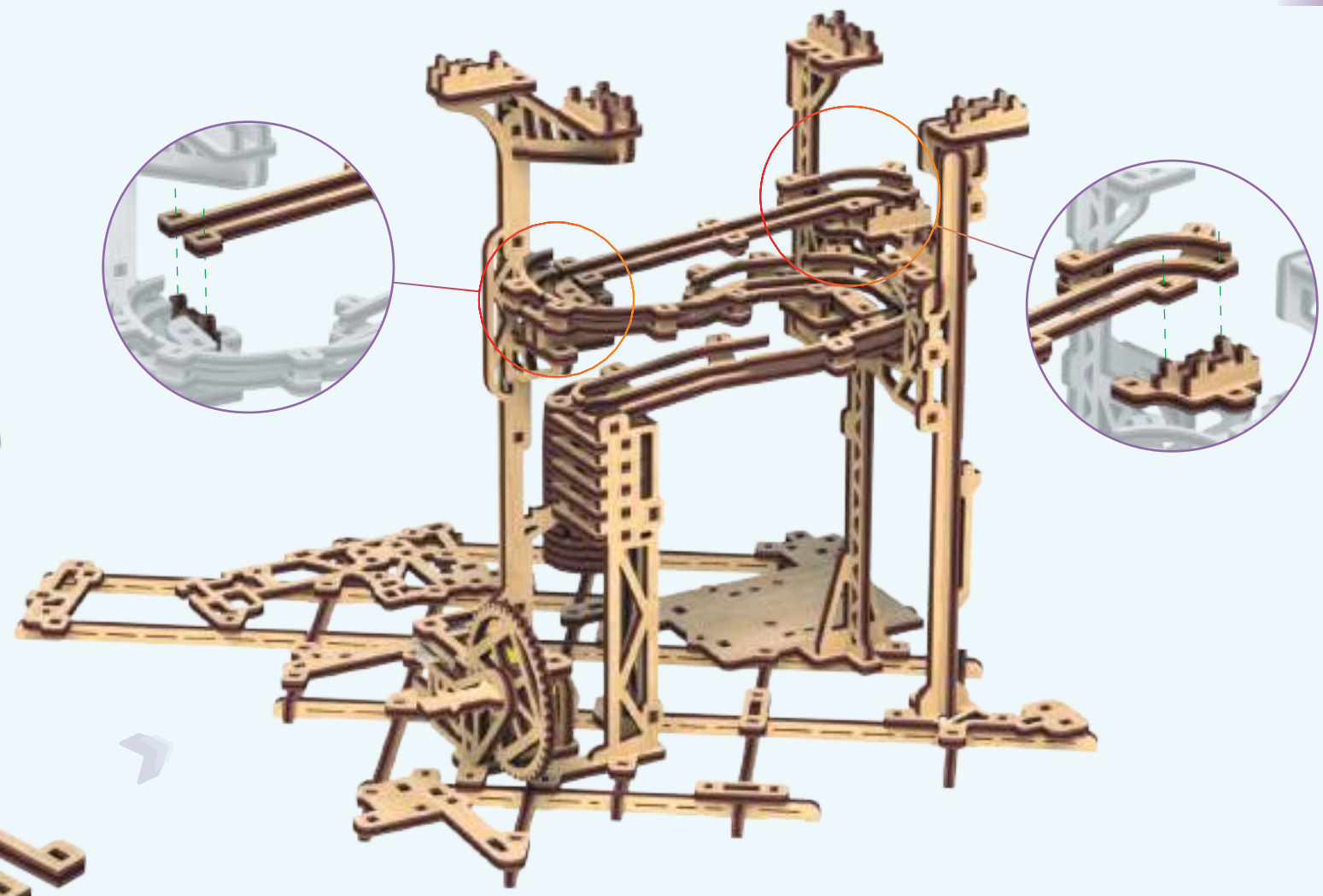
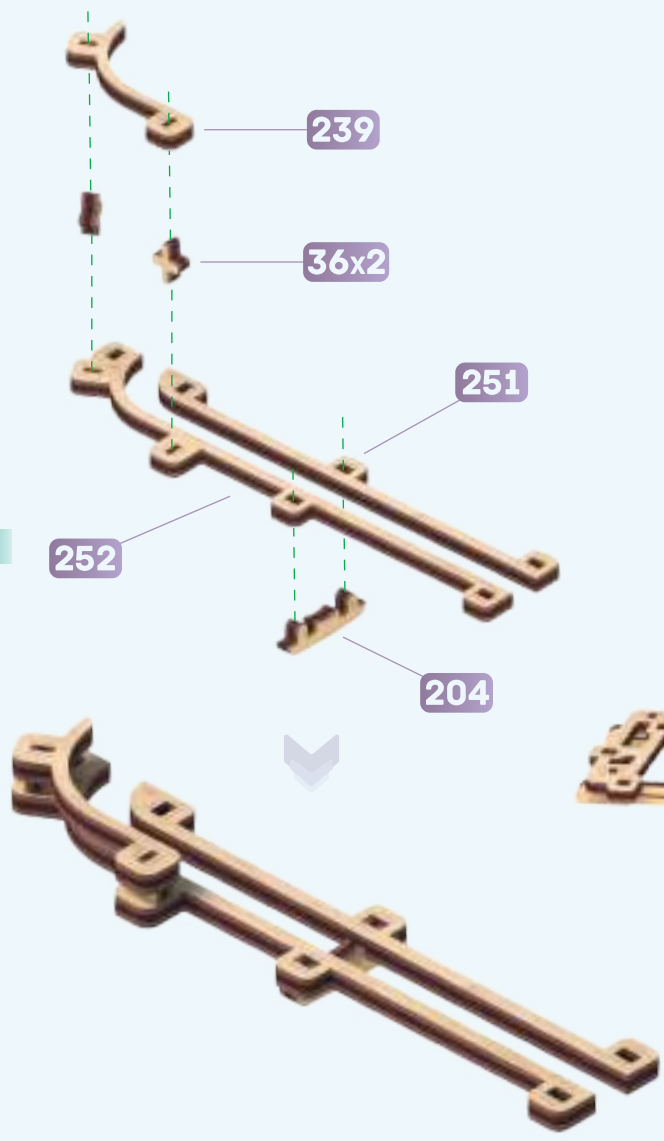

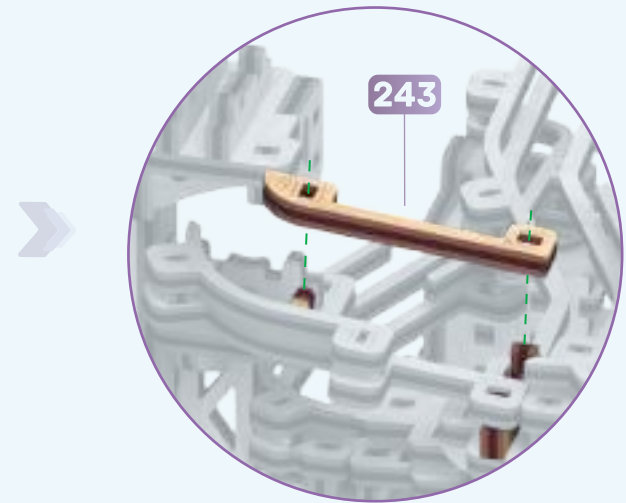
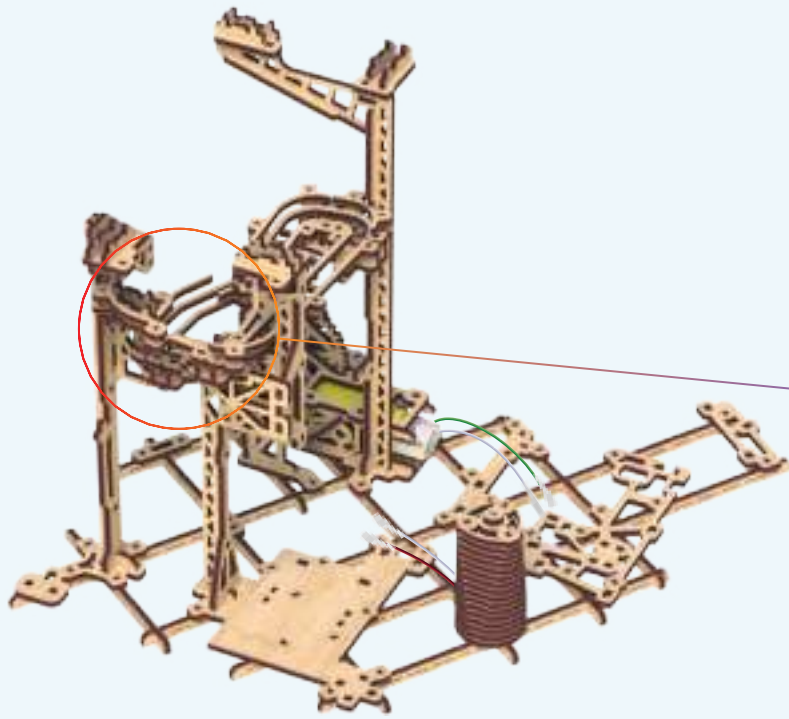
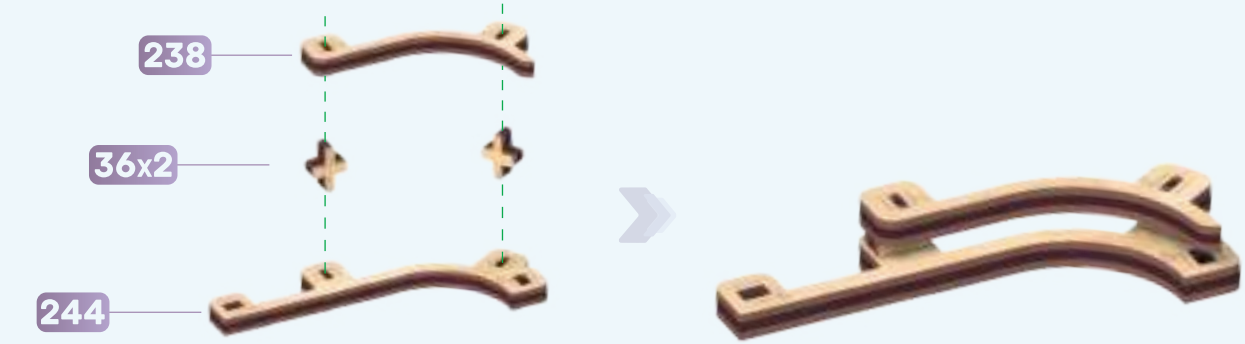

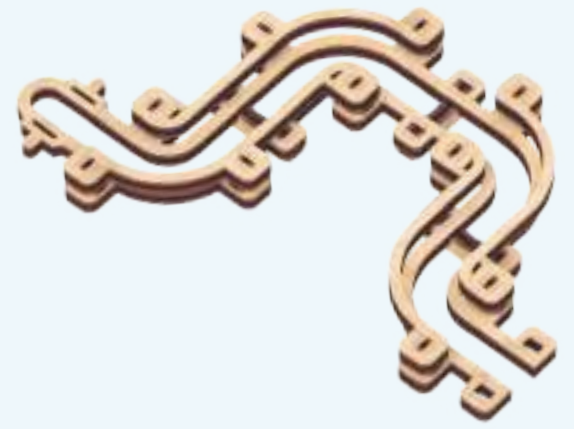
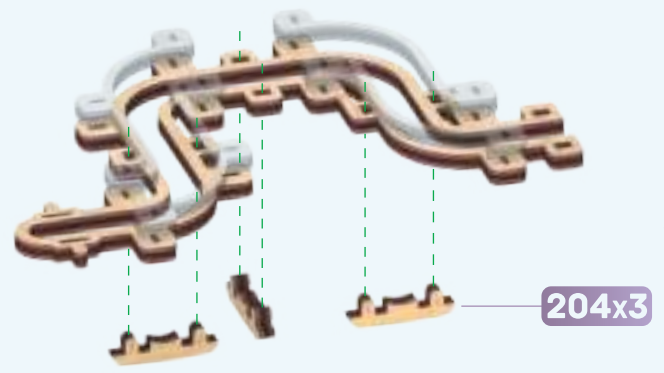
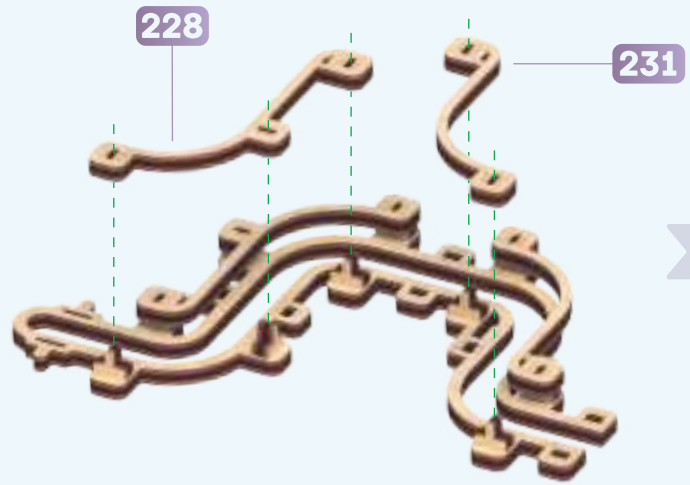
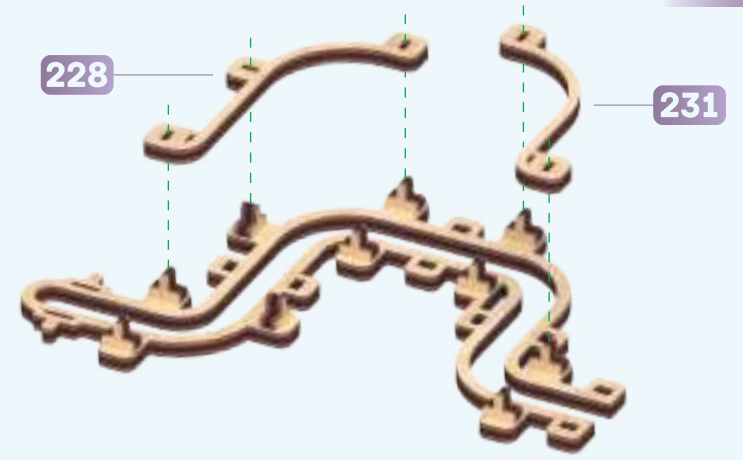
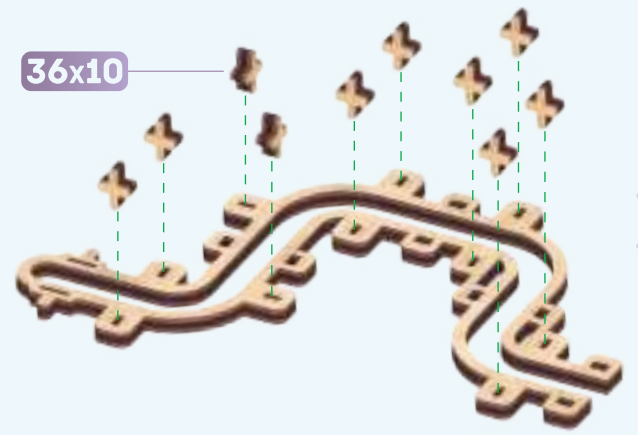
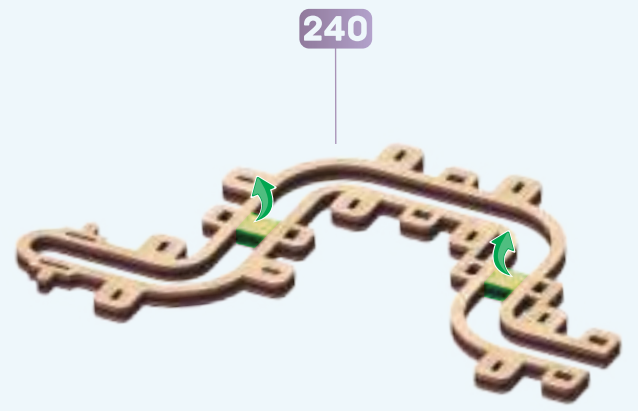
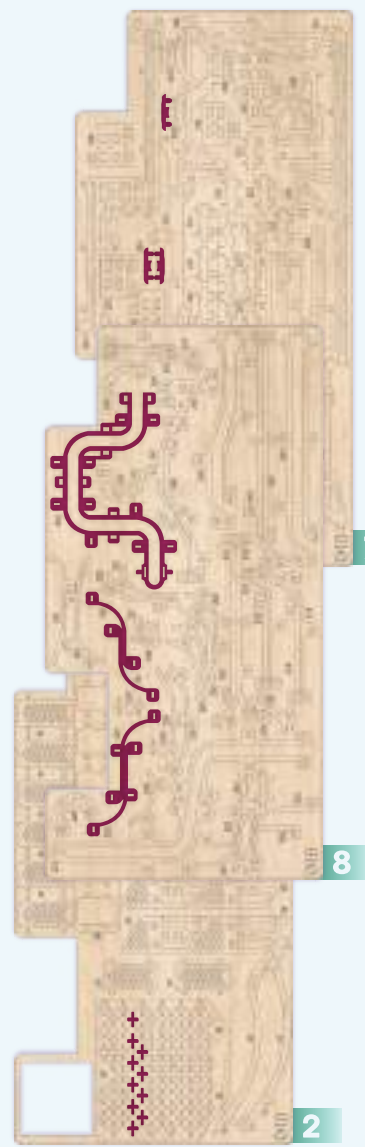

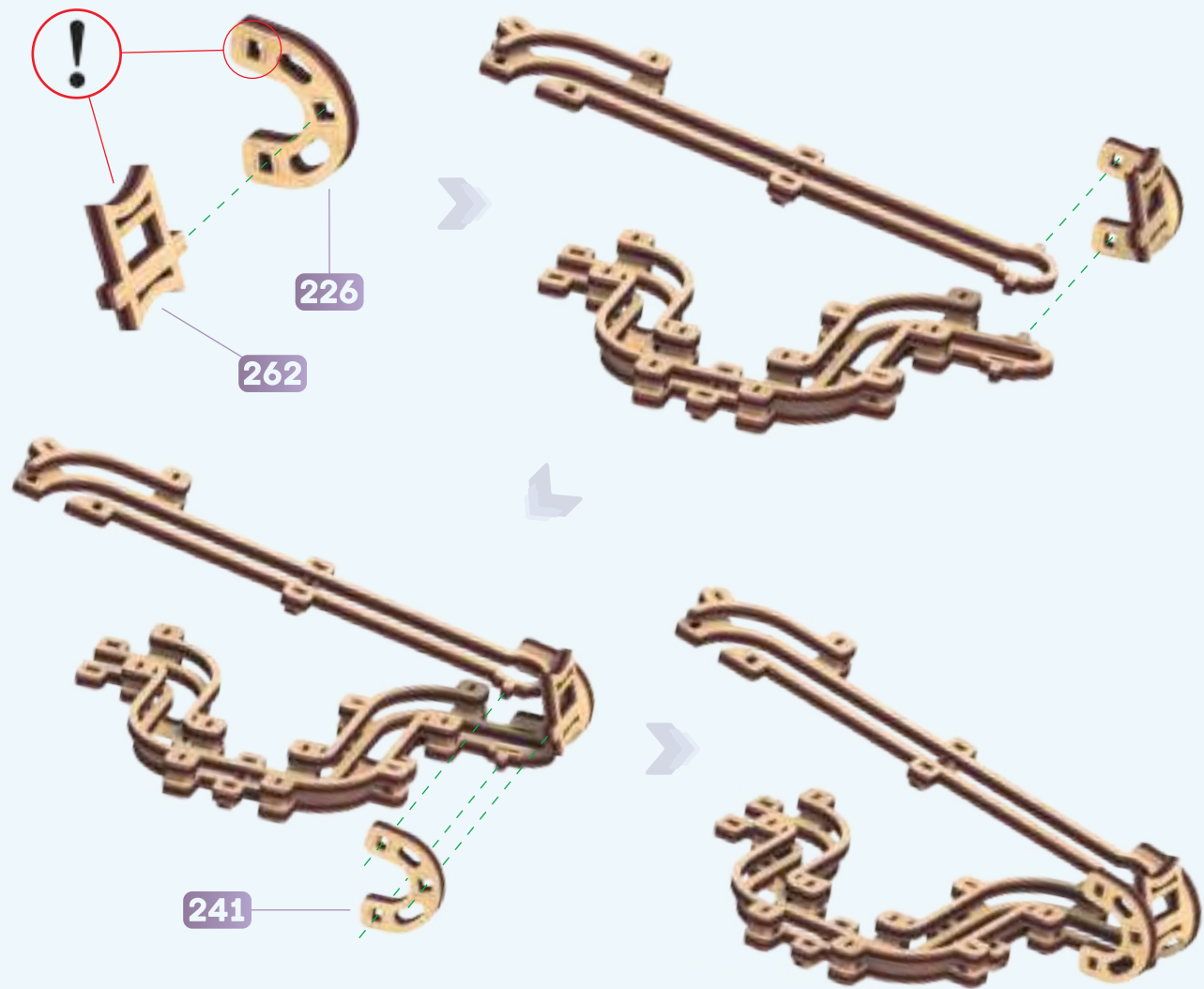

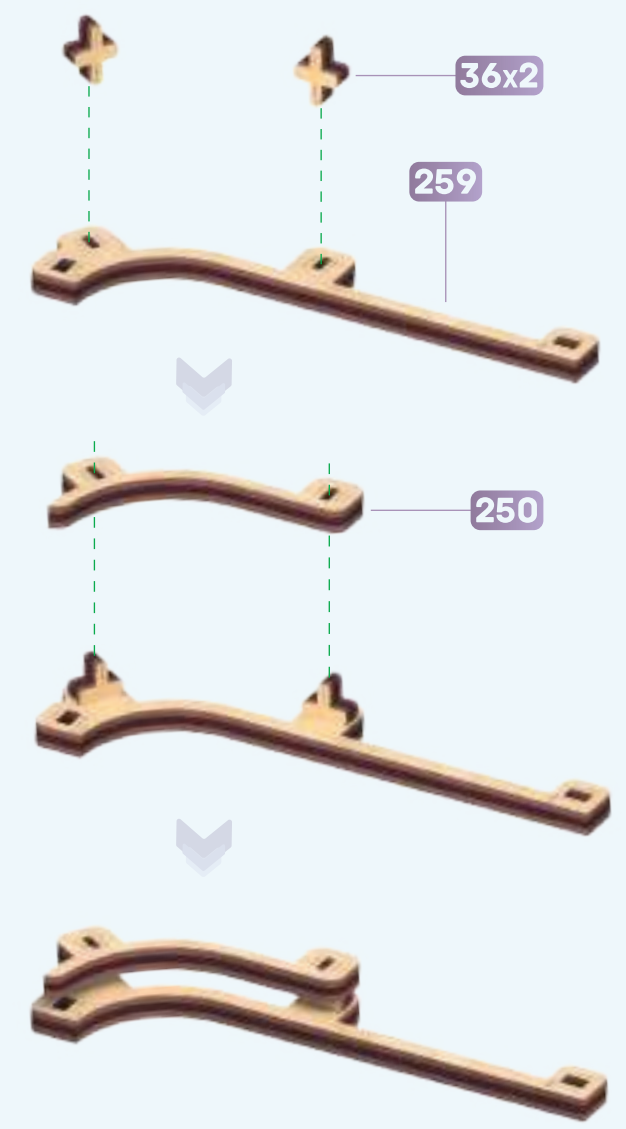
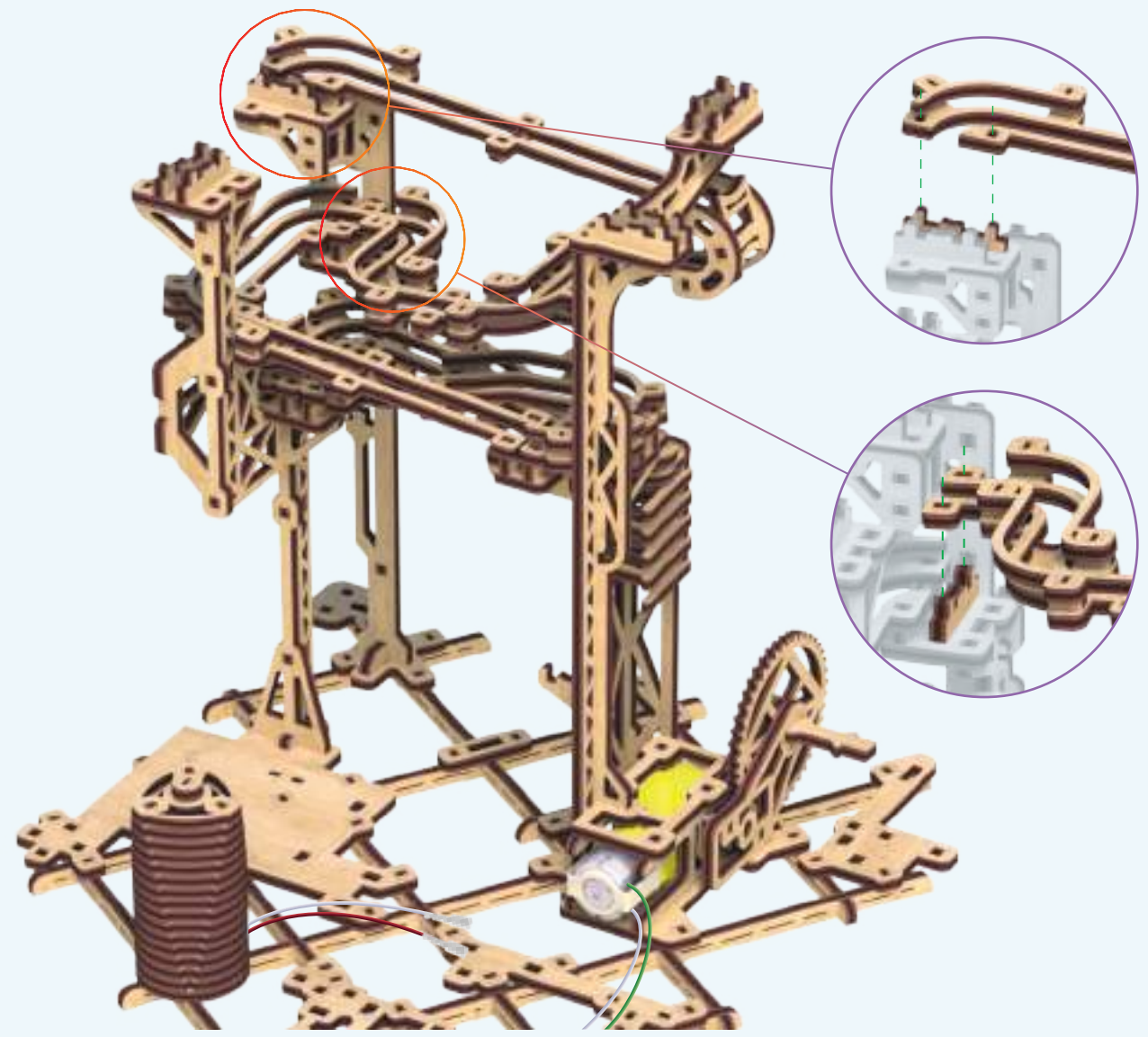

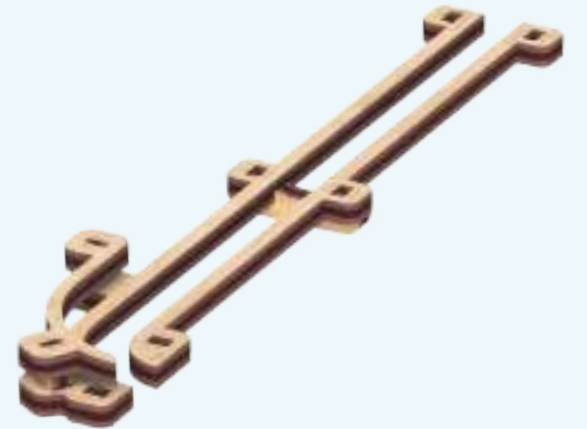
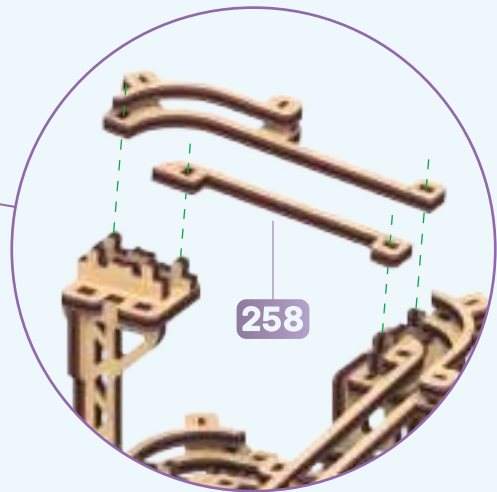
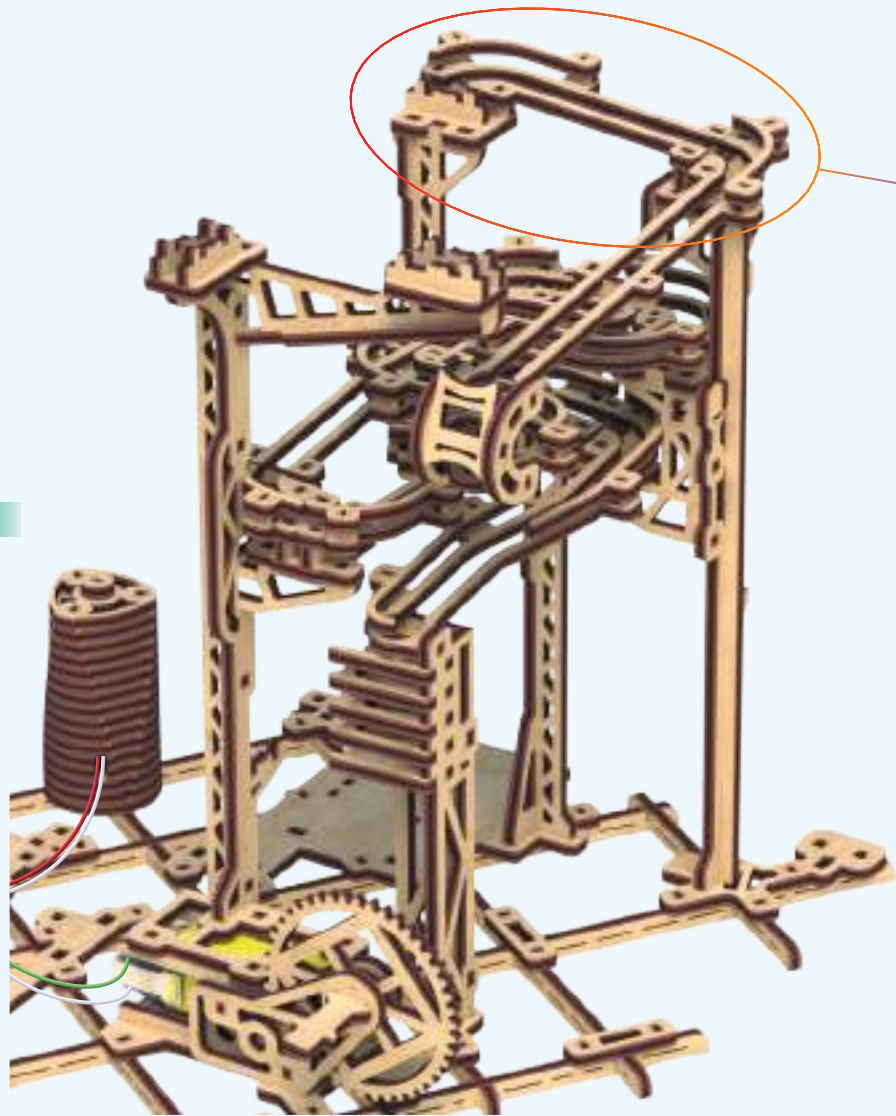

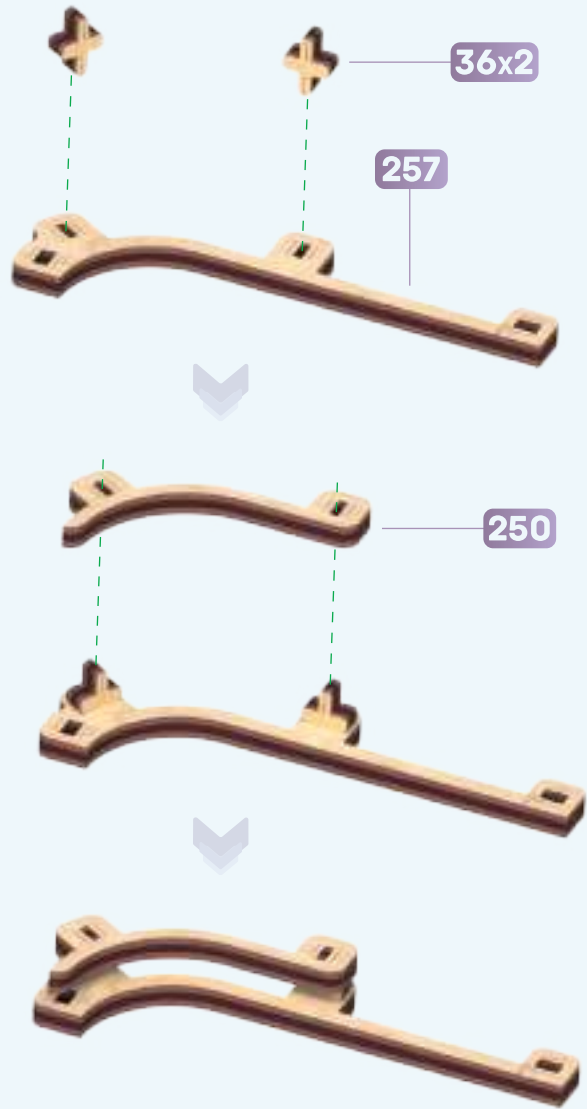
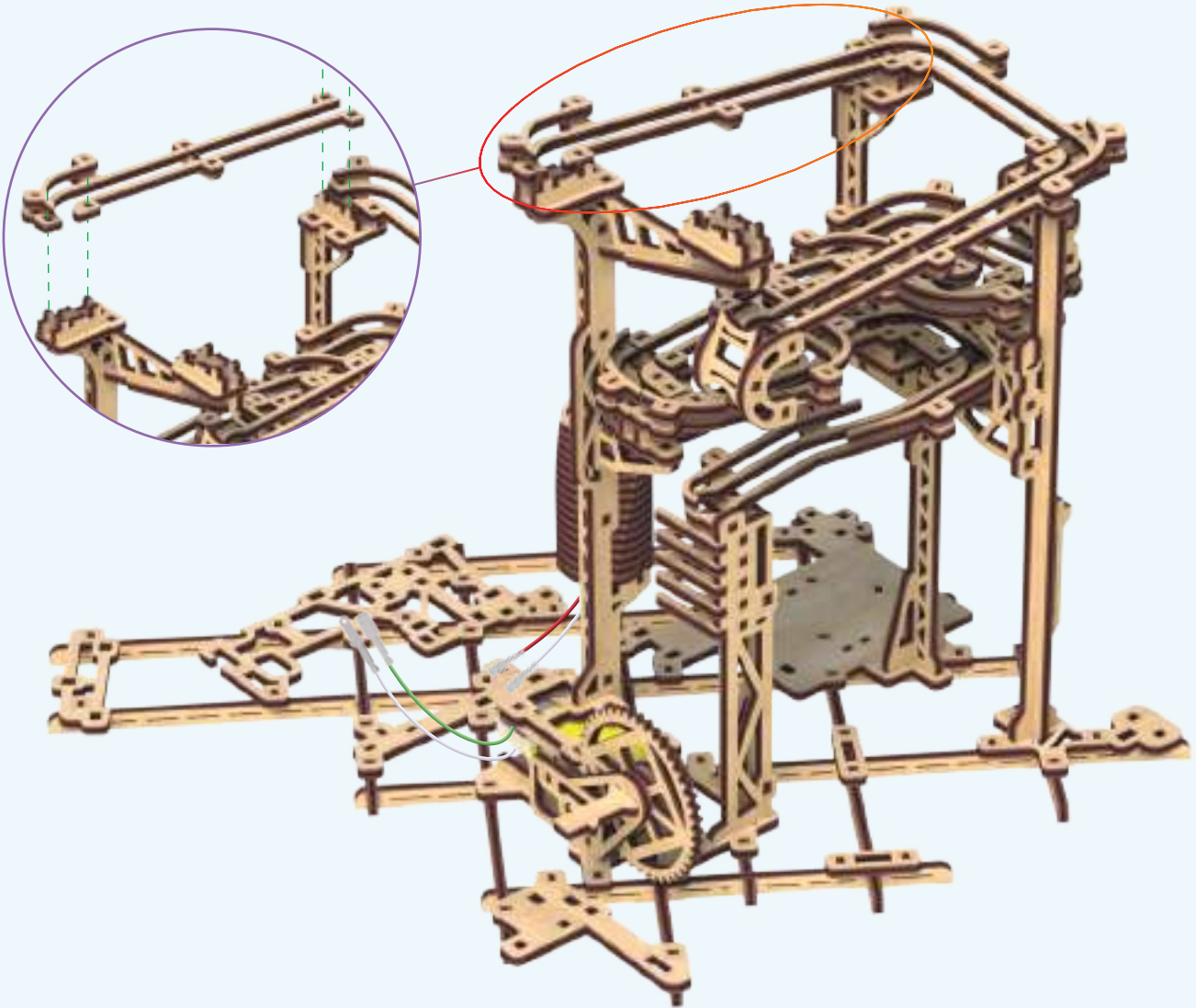
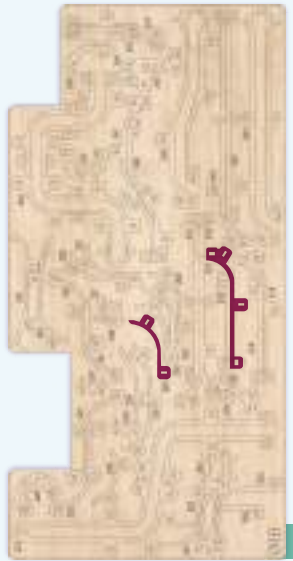

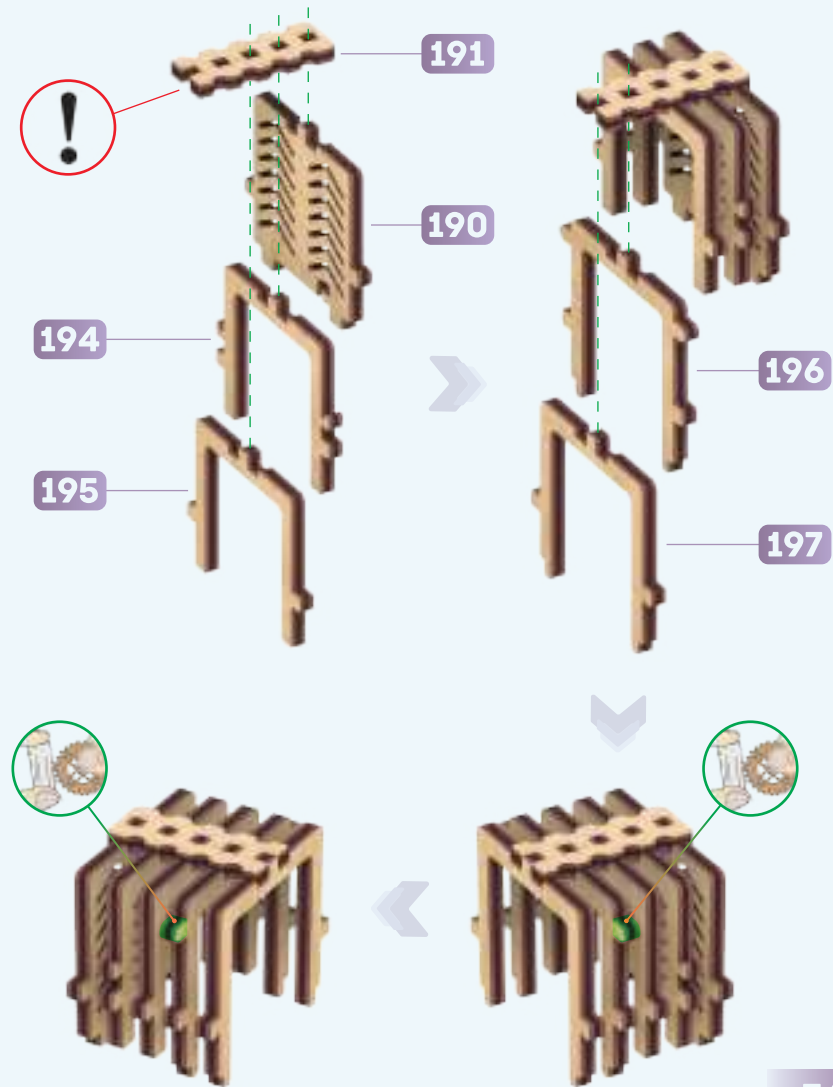
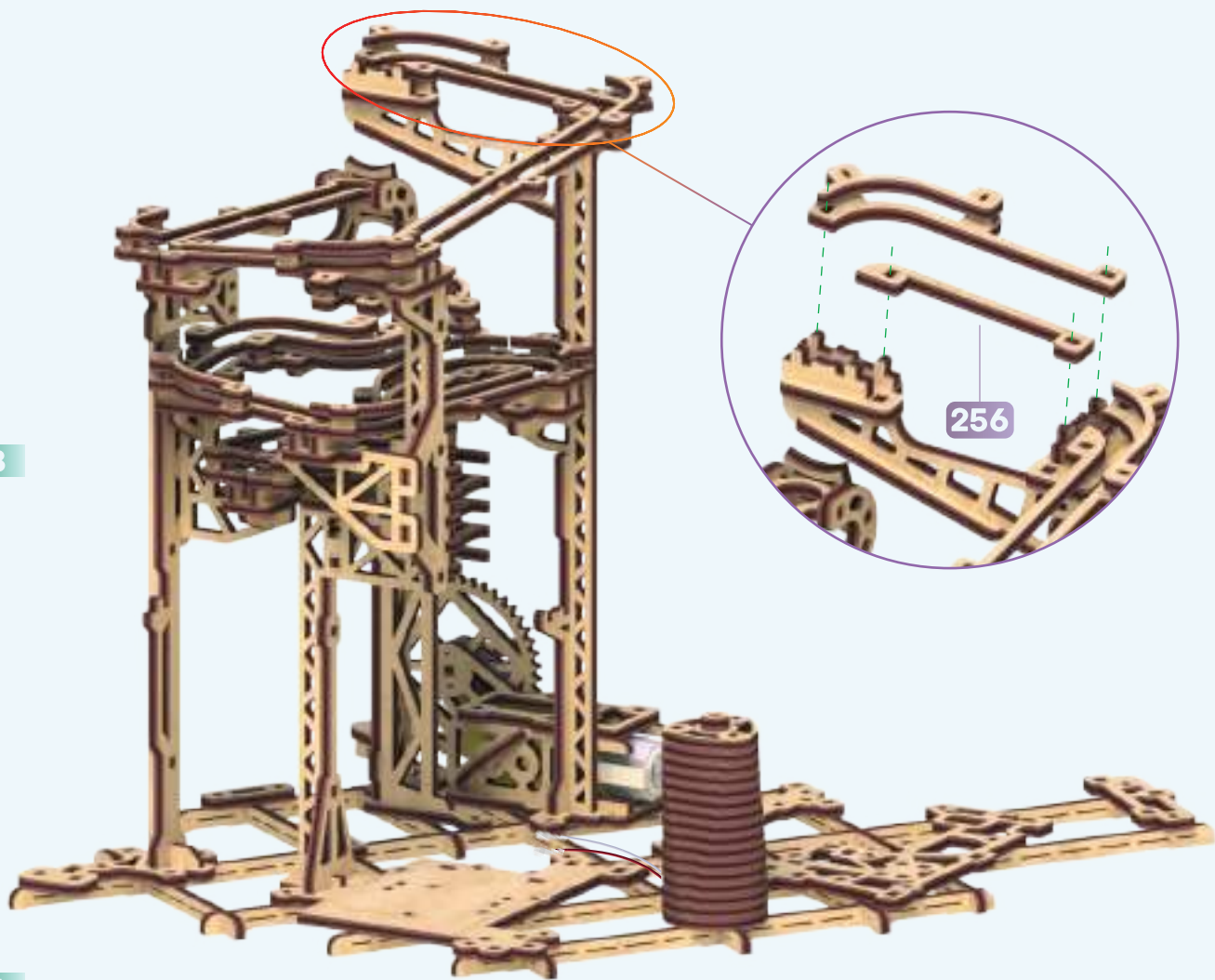
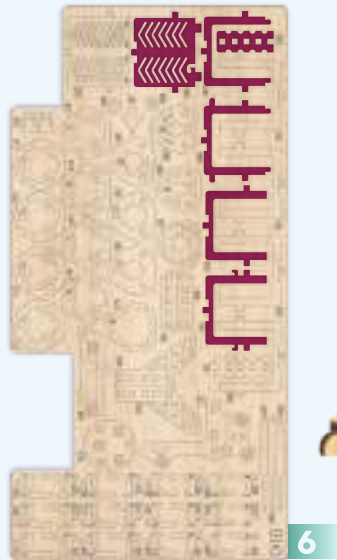

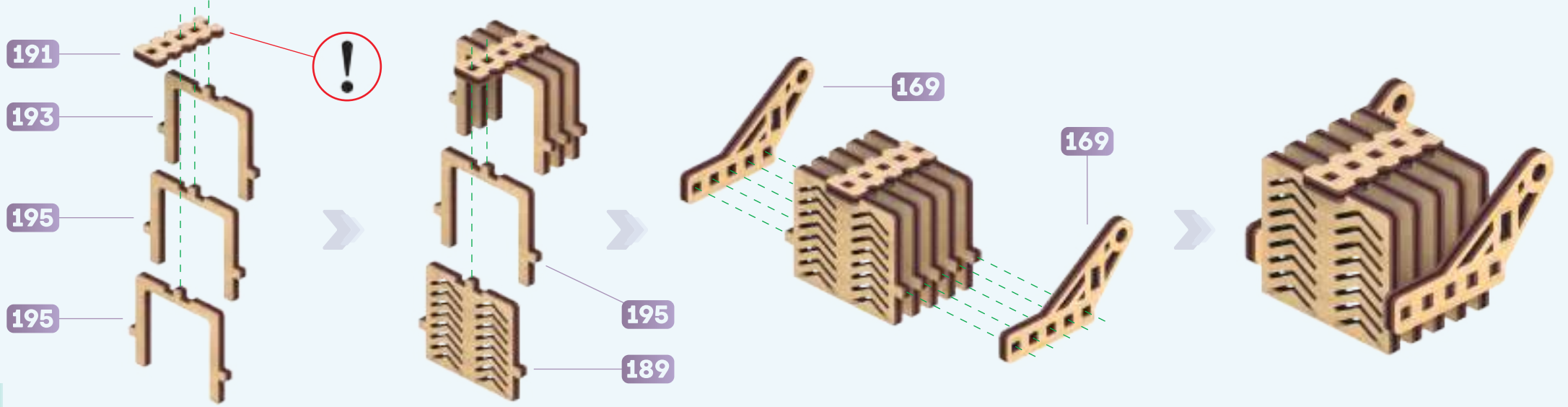
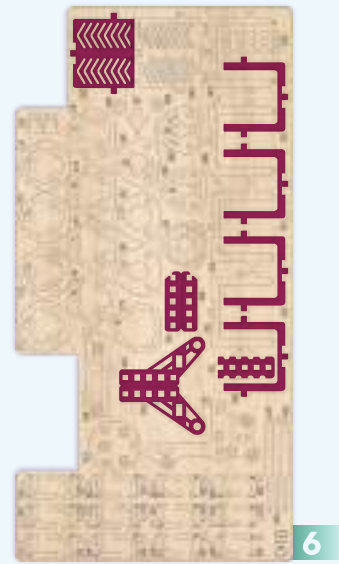
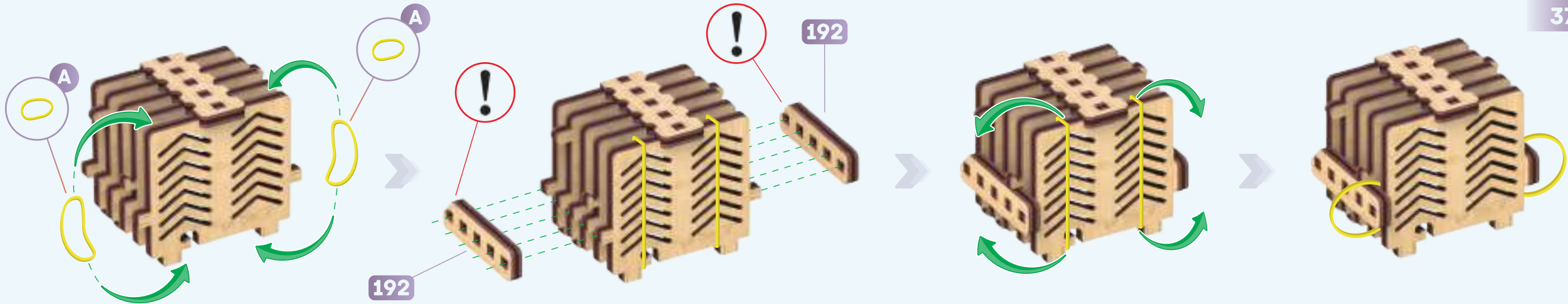

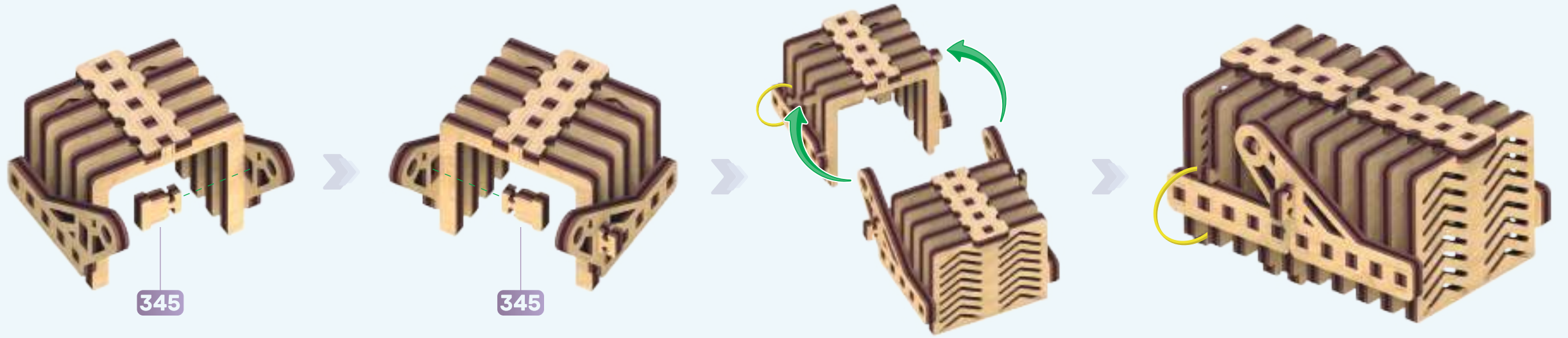

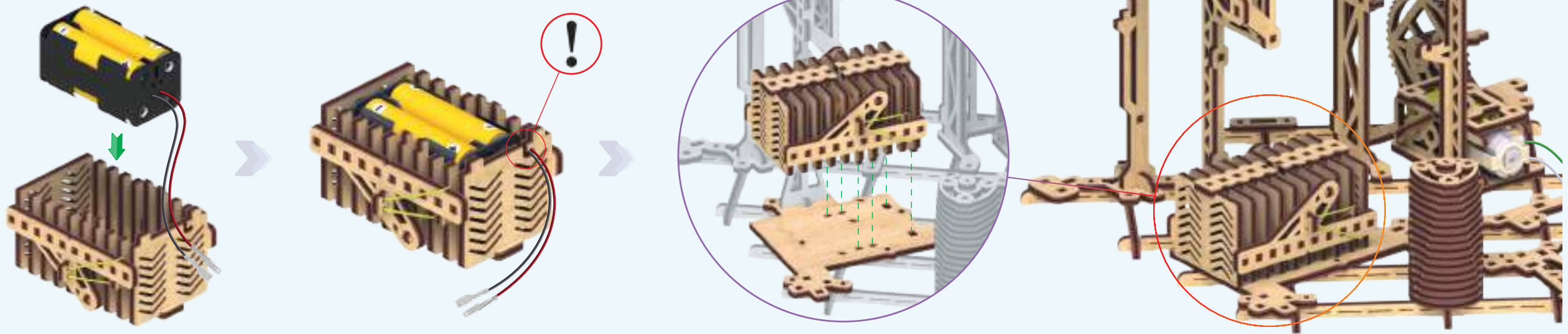
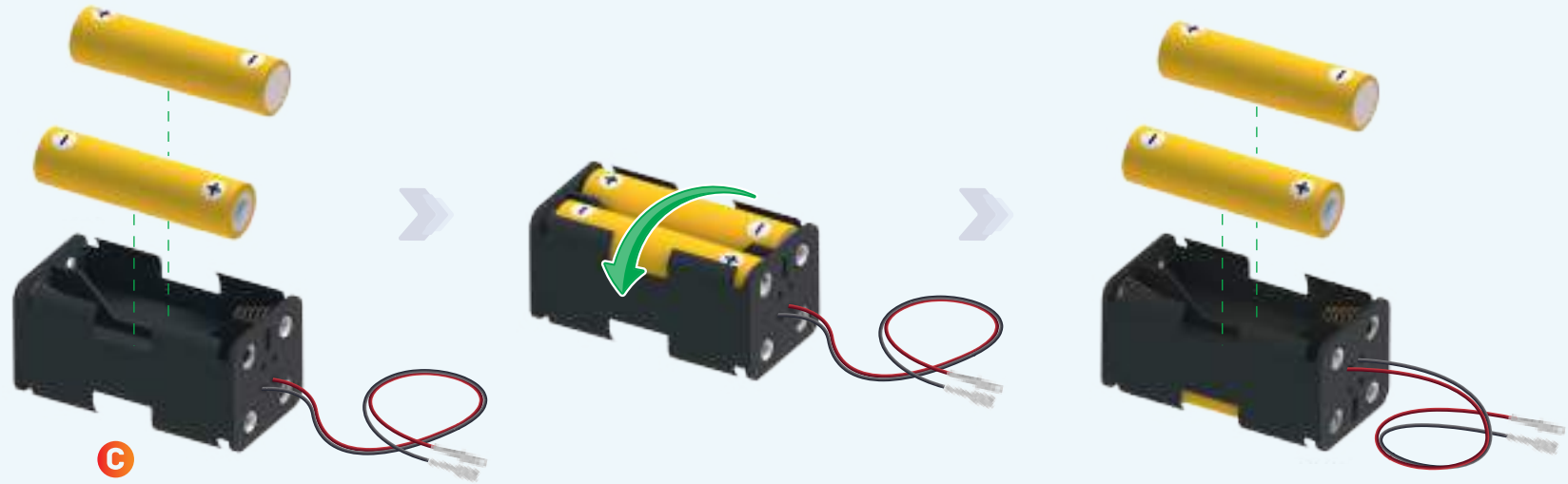



9

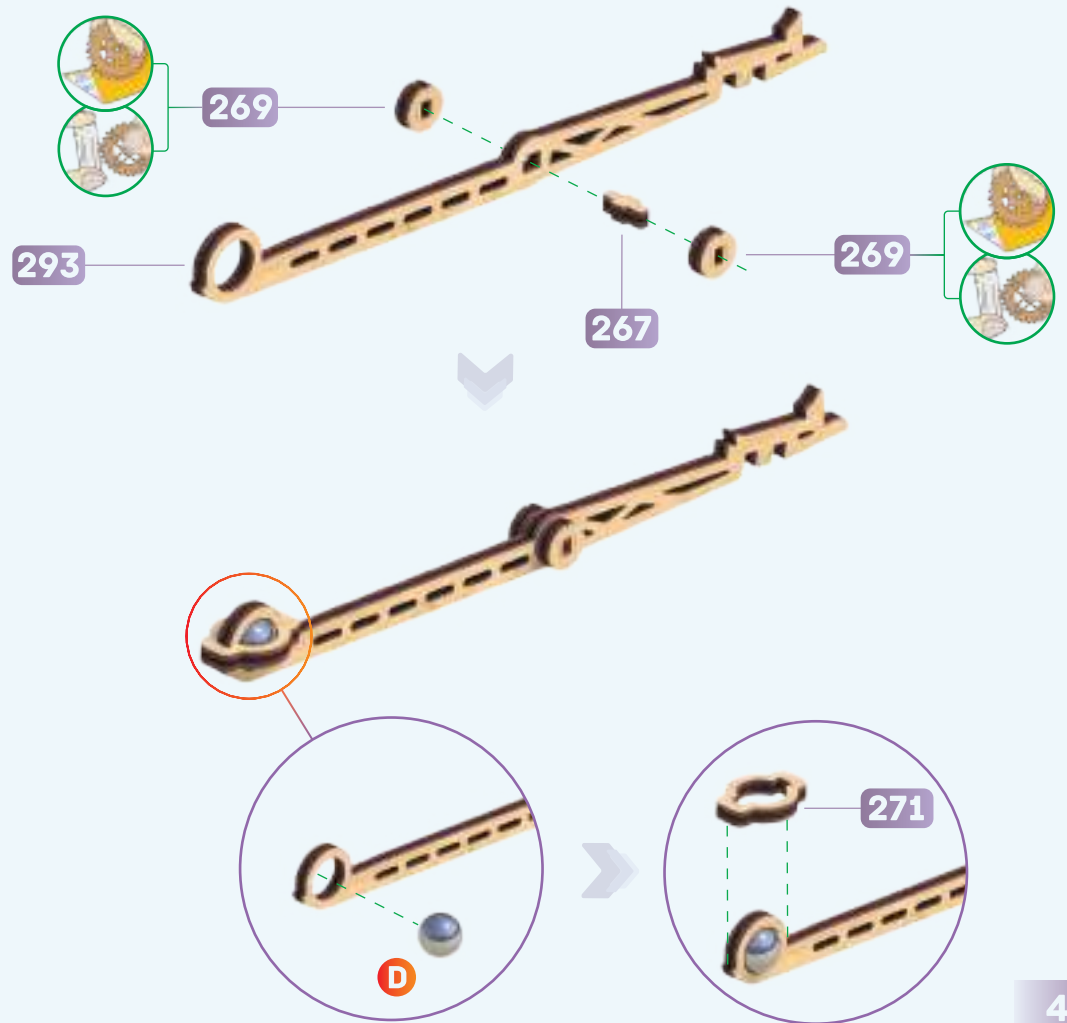
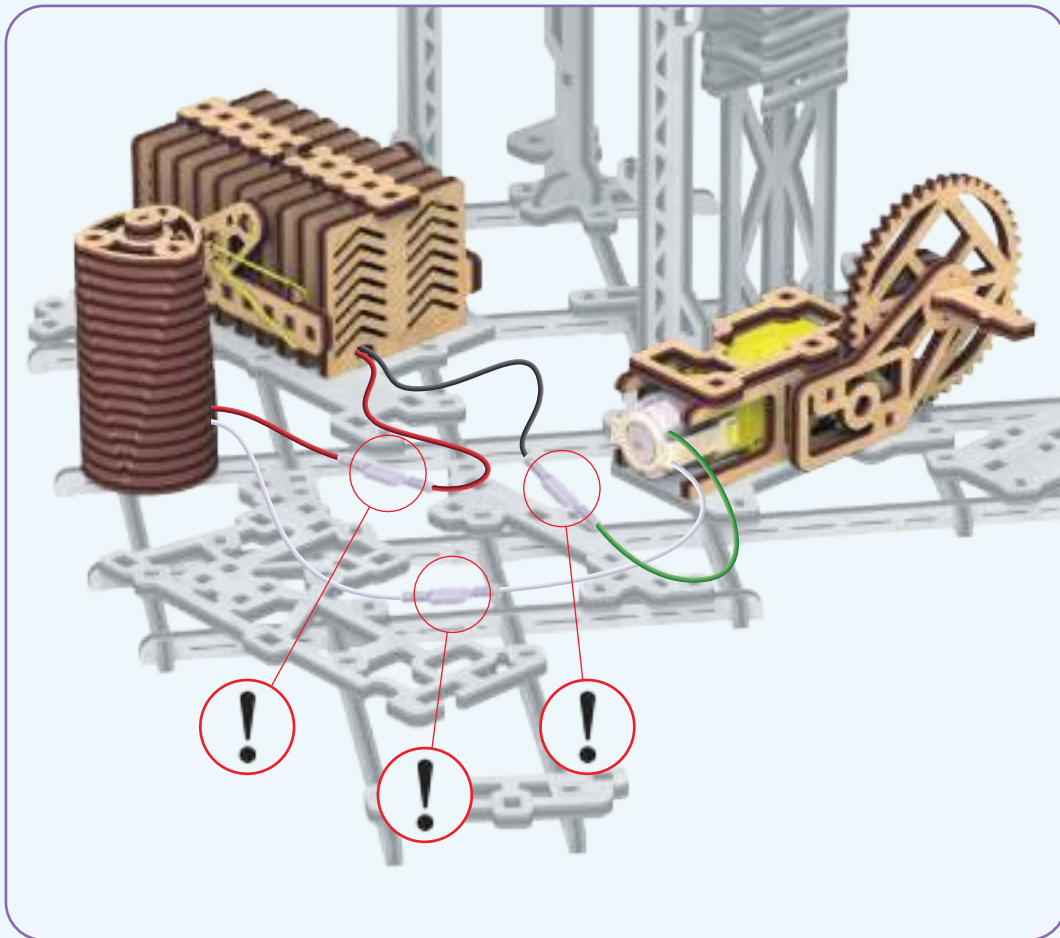

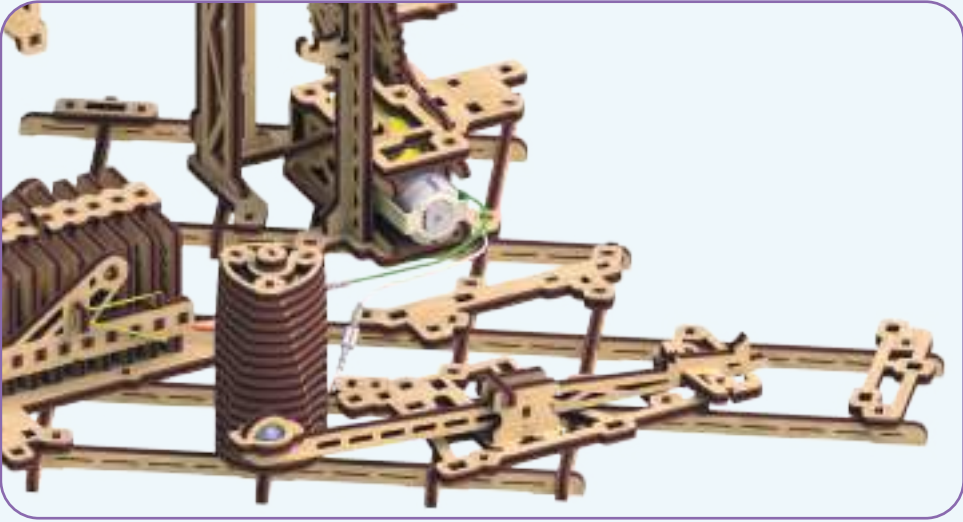
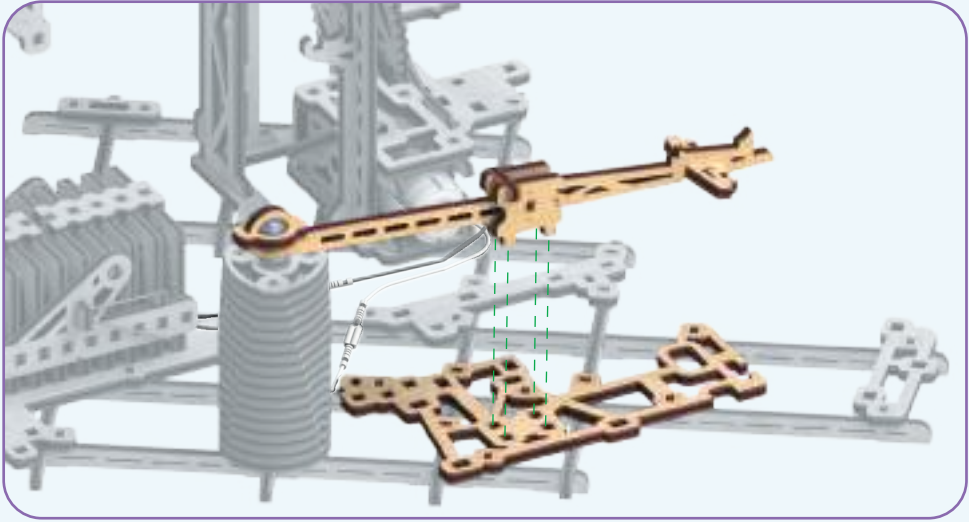
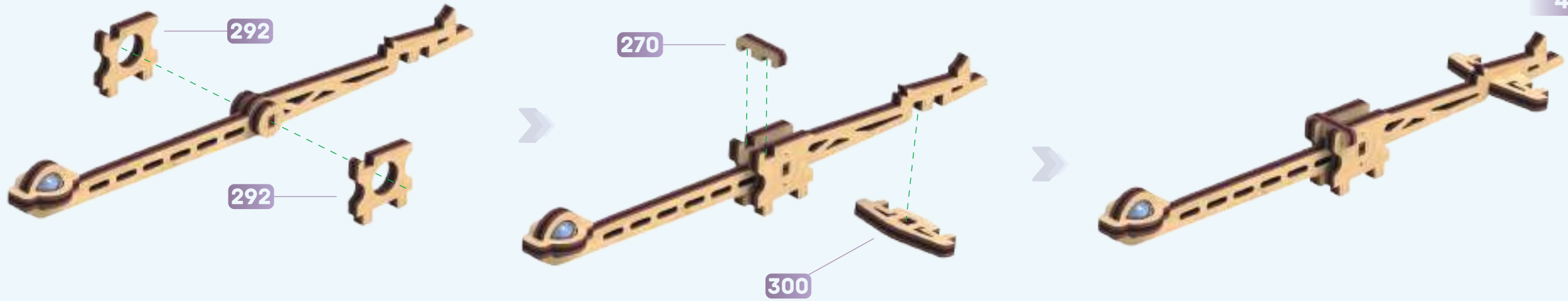

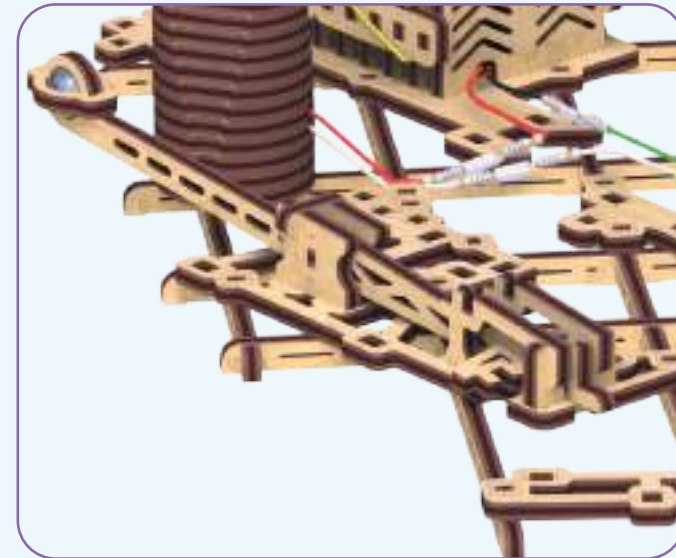
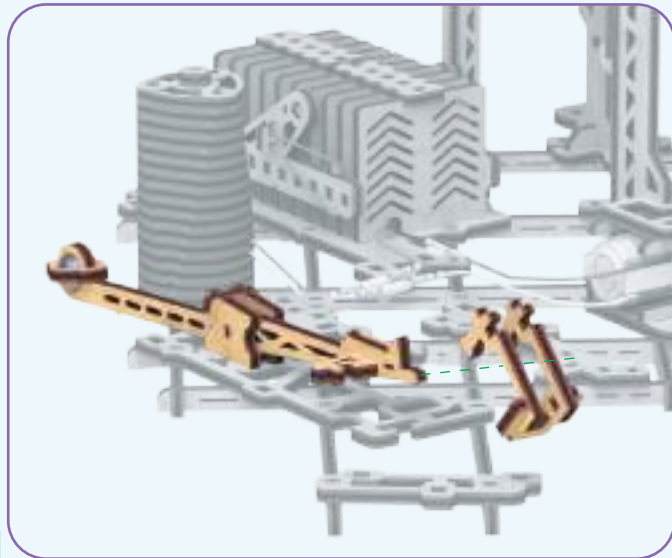

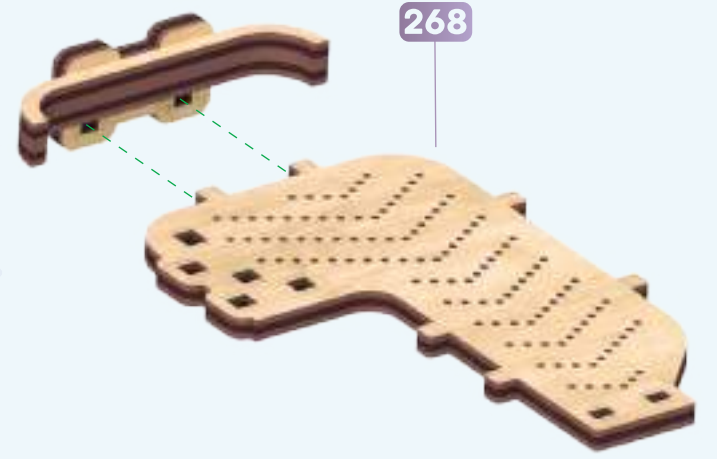
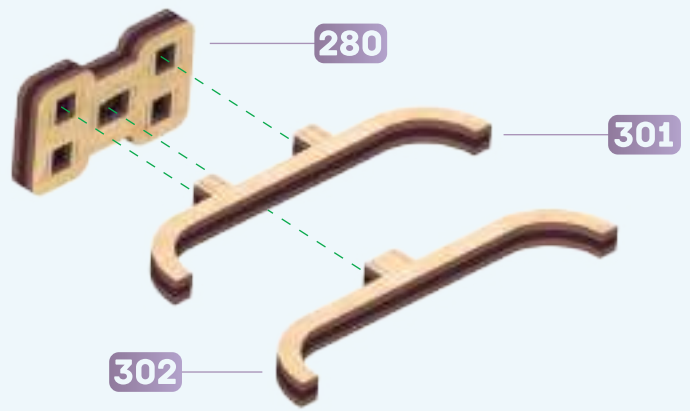
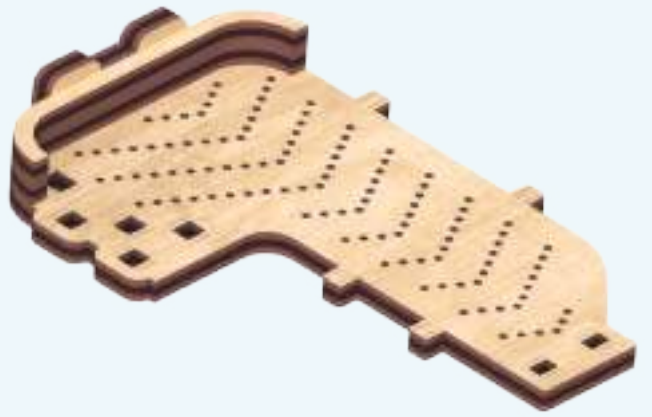
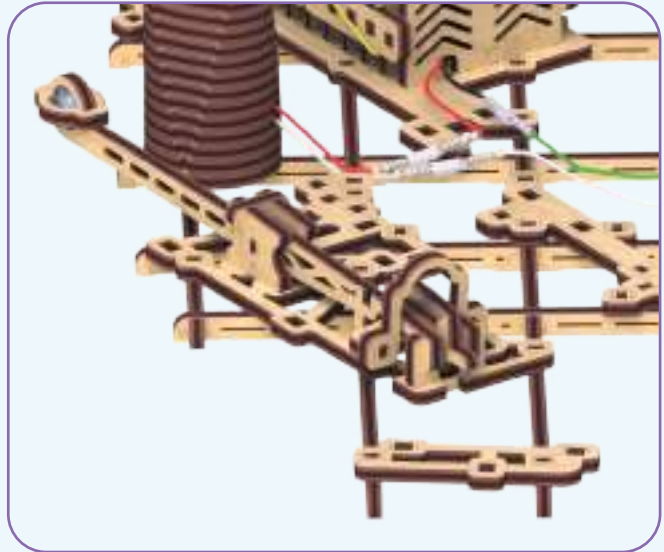
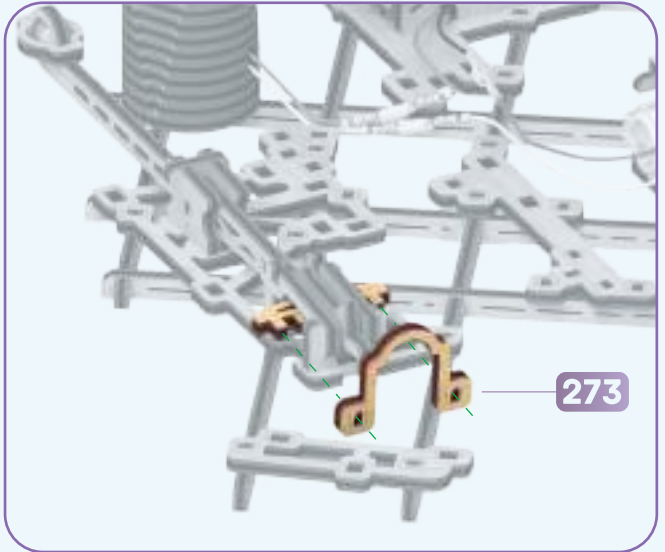

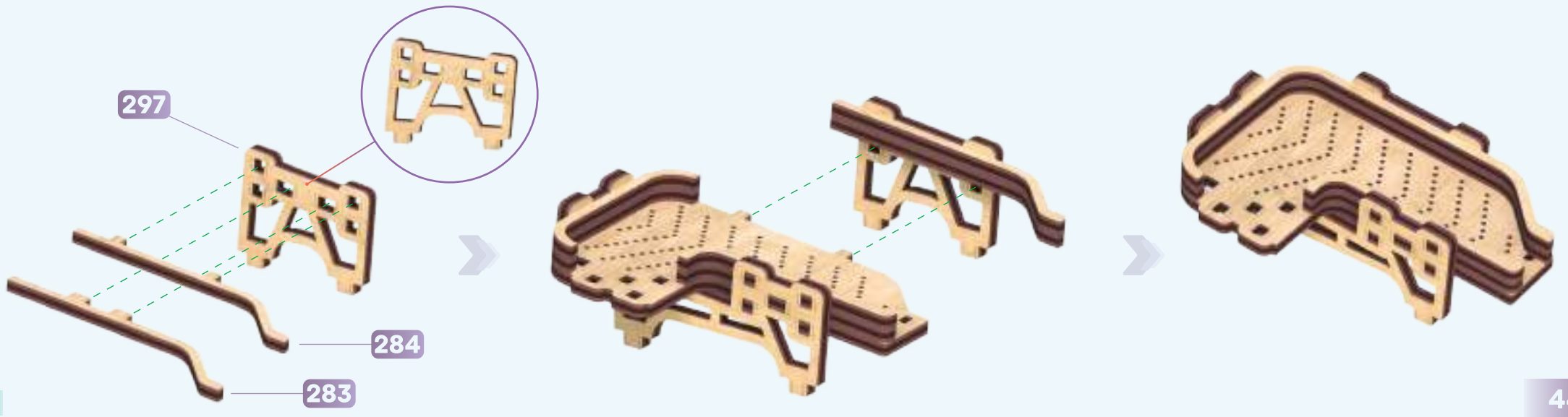
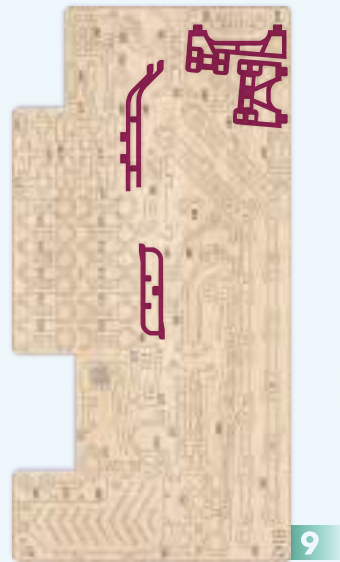
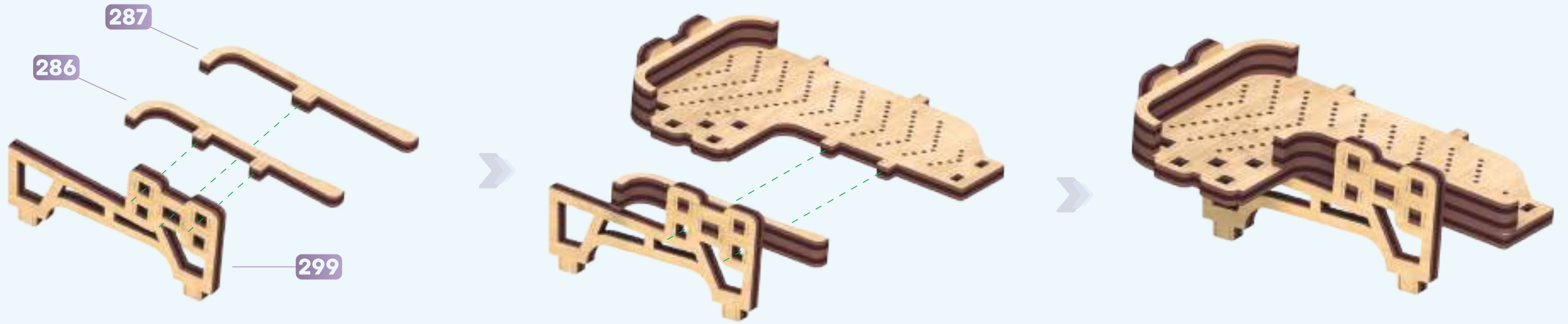

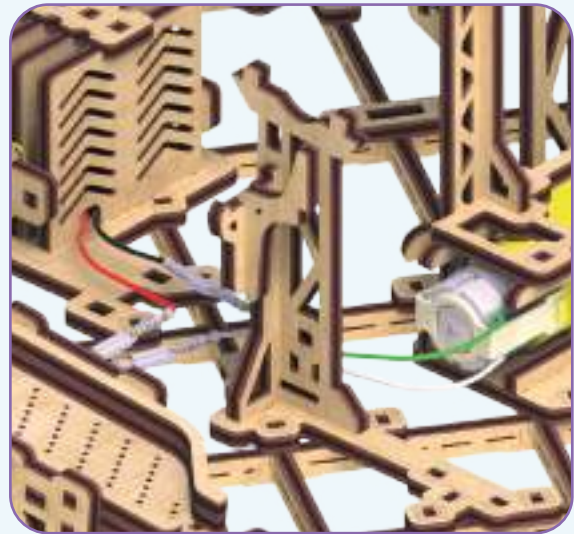
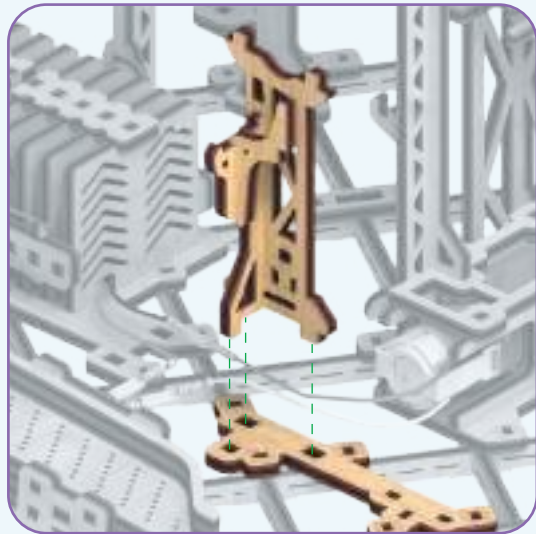
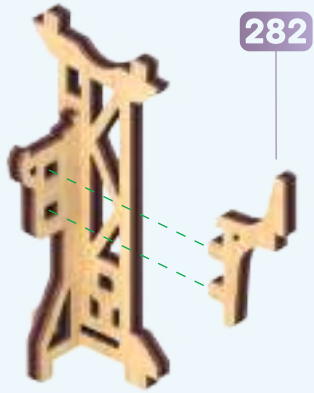
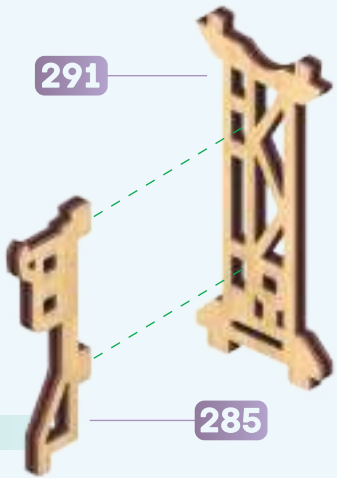
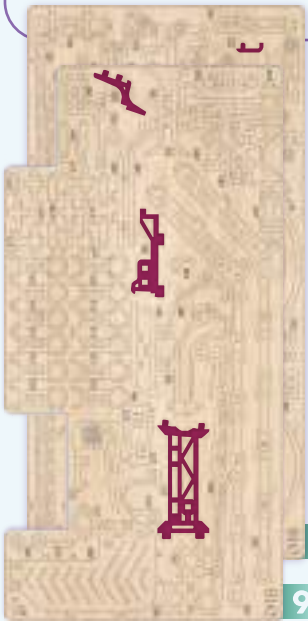
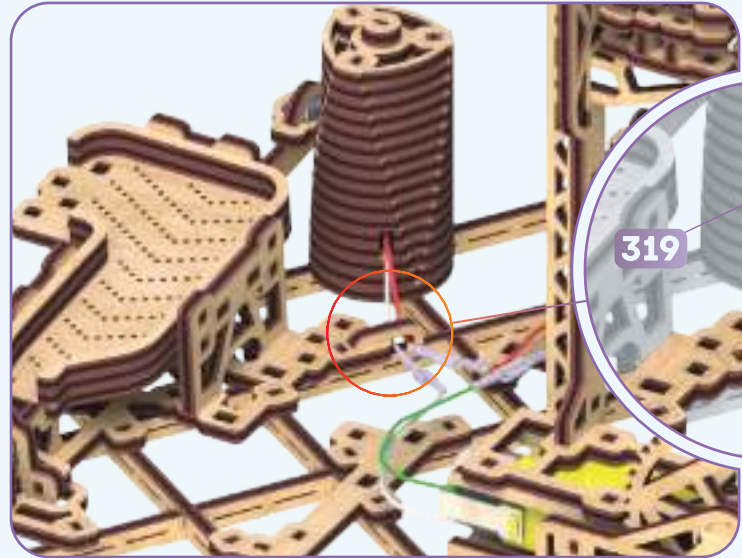
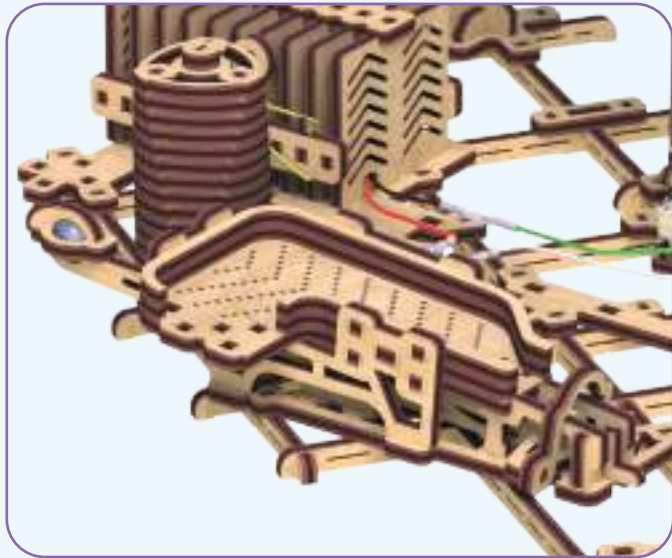
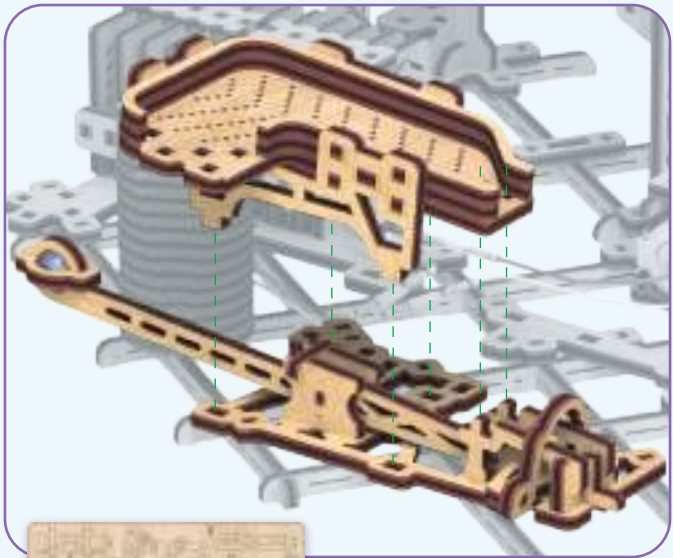

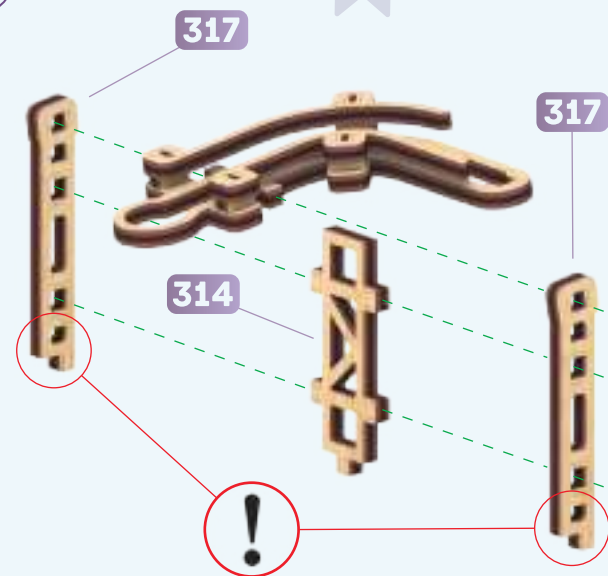
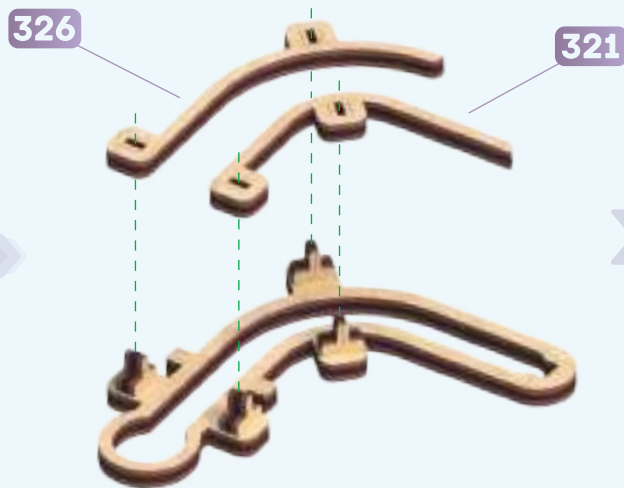
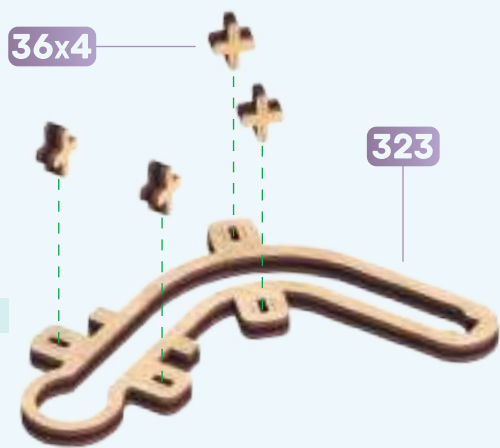
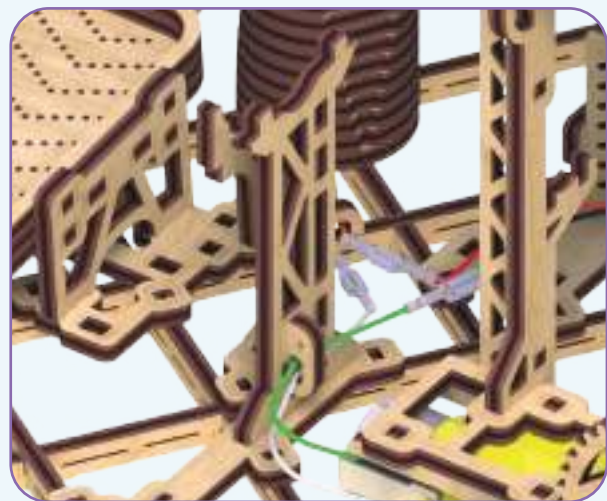
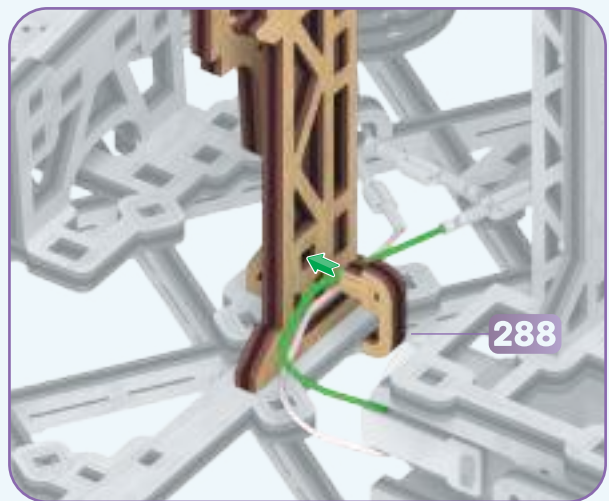
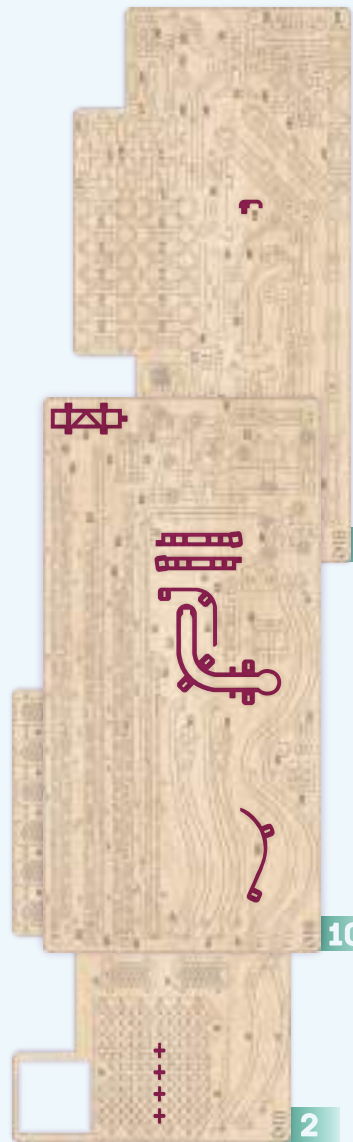

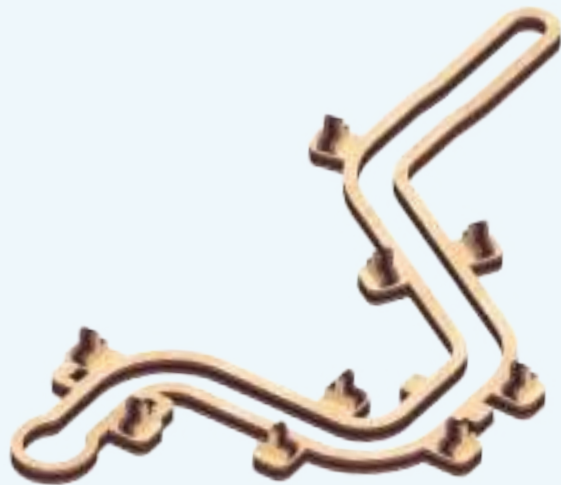
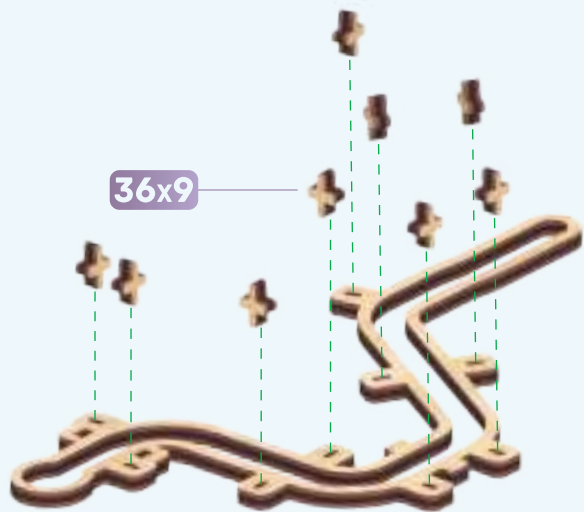
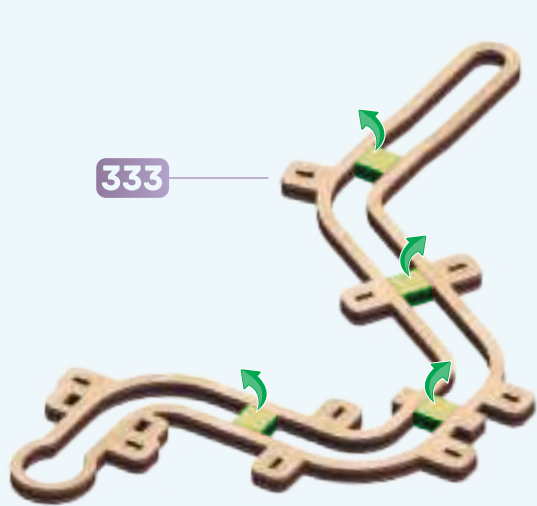
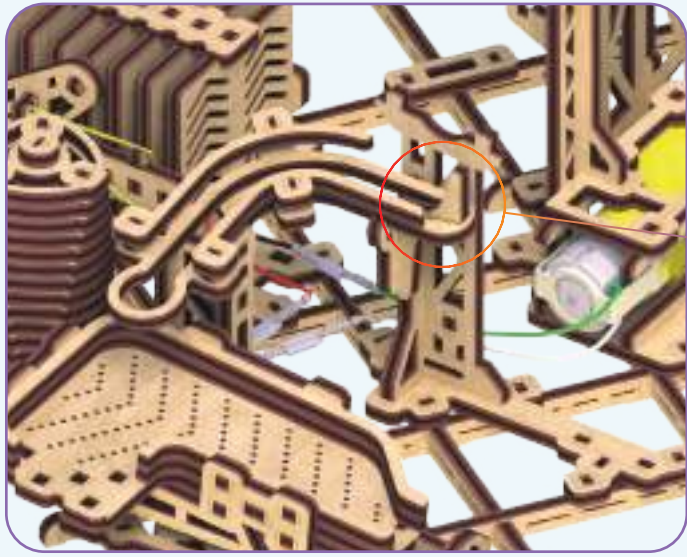
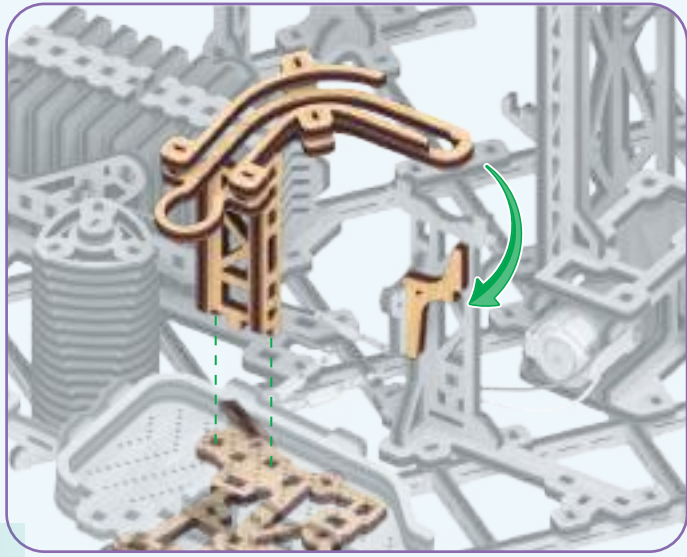

338

342

340

340

341

334

337

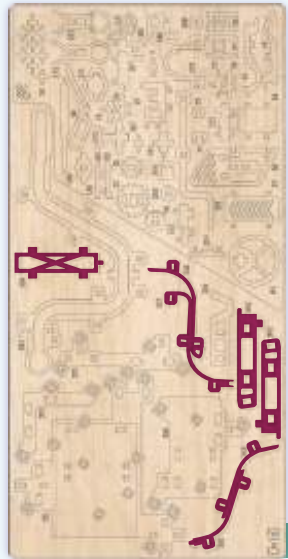

11

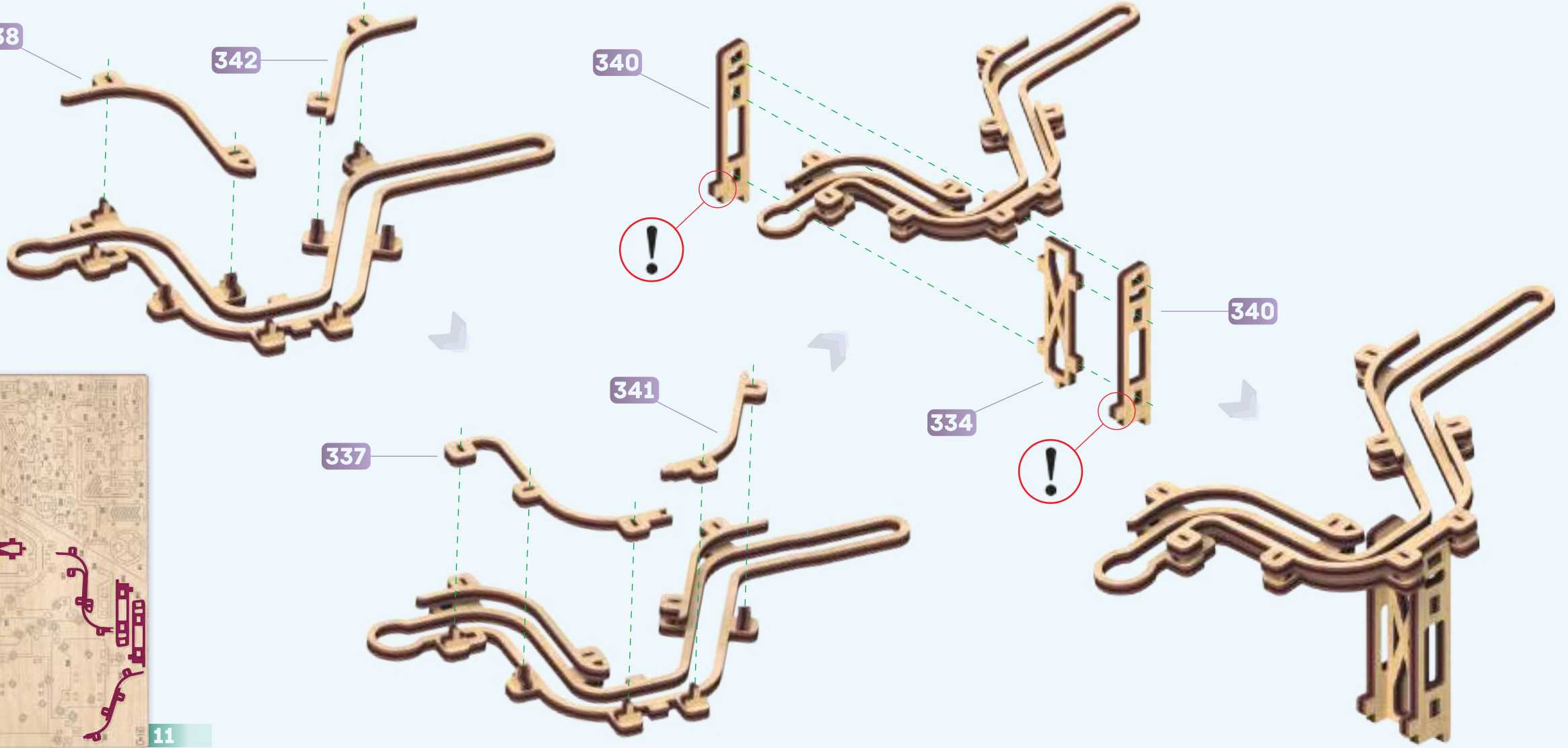

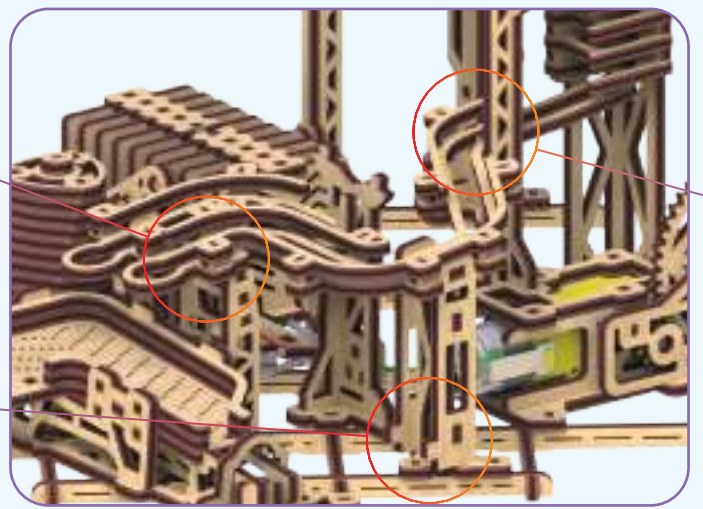
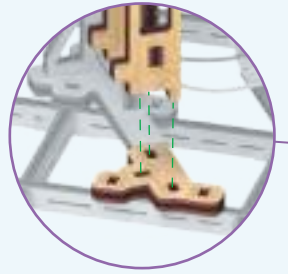
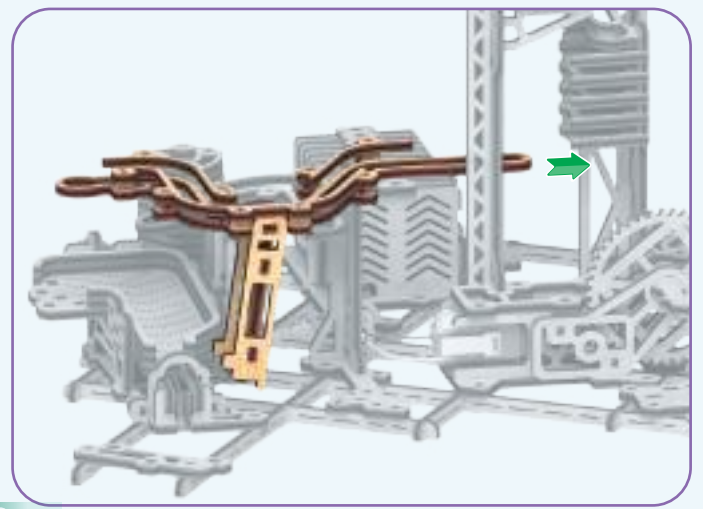
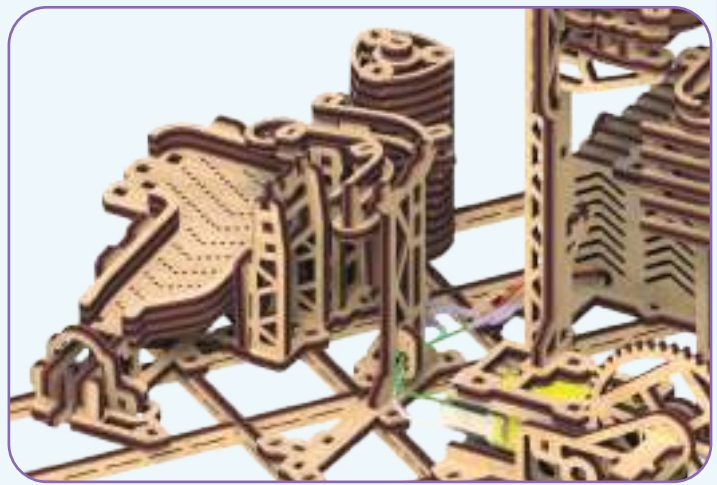
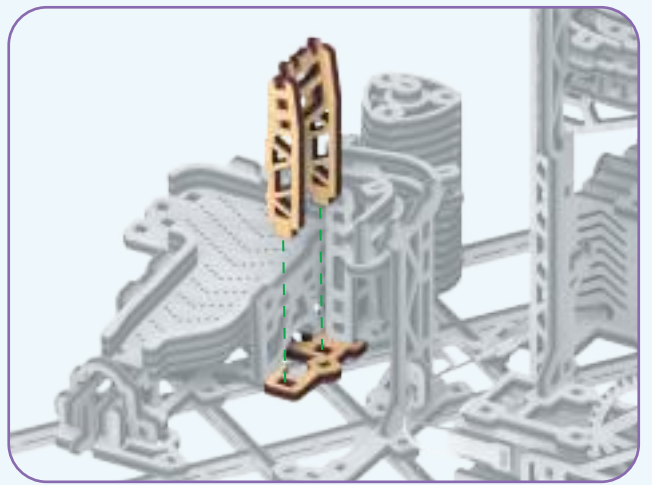
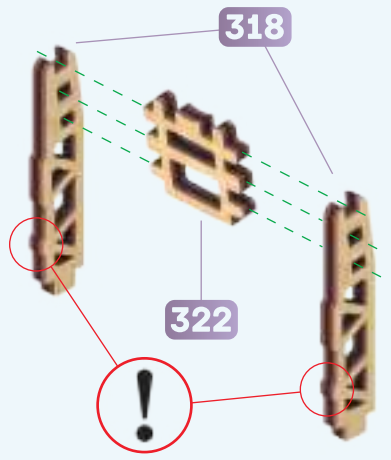

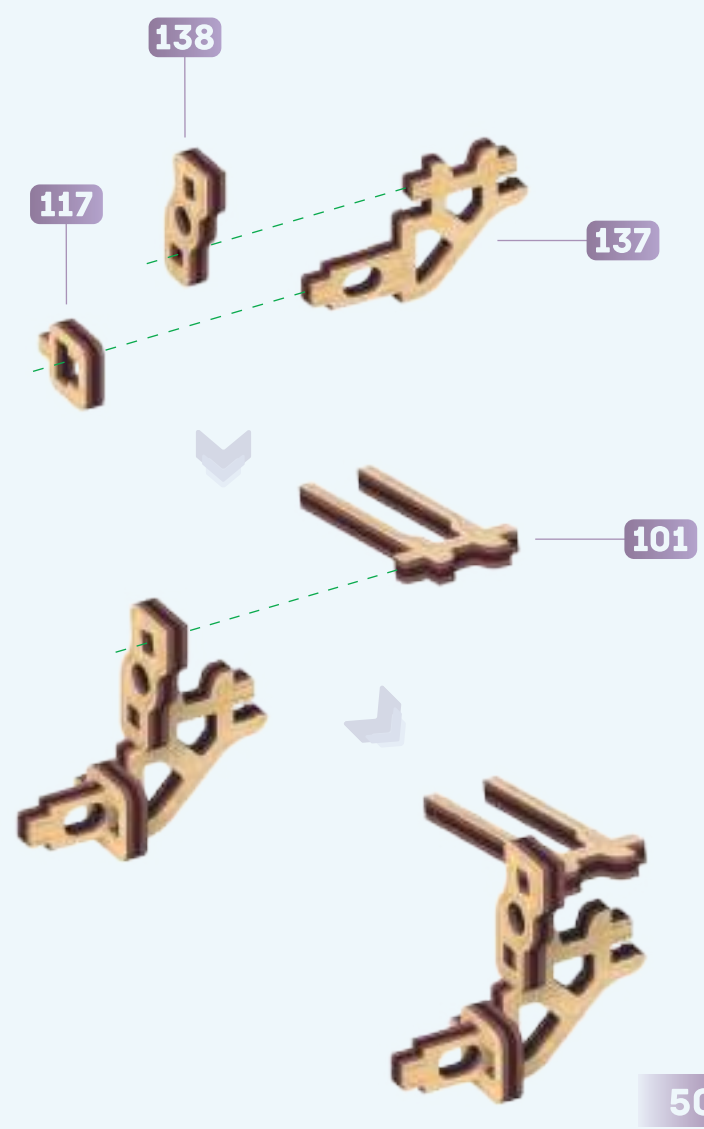
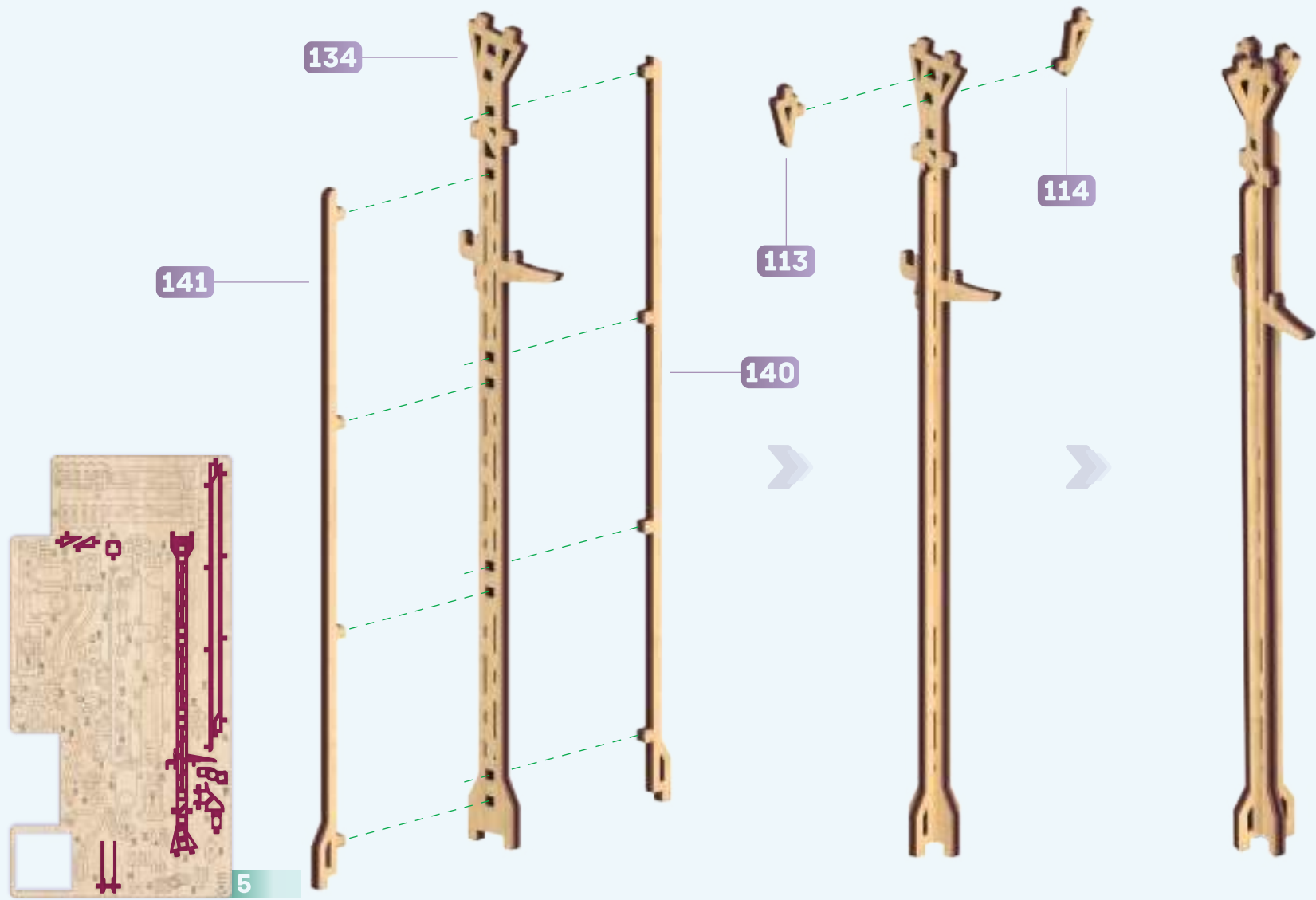

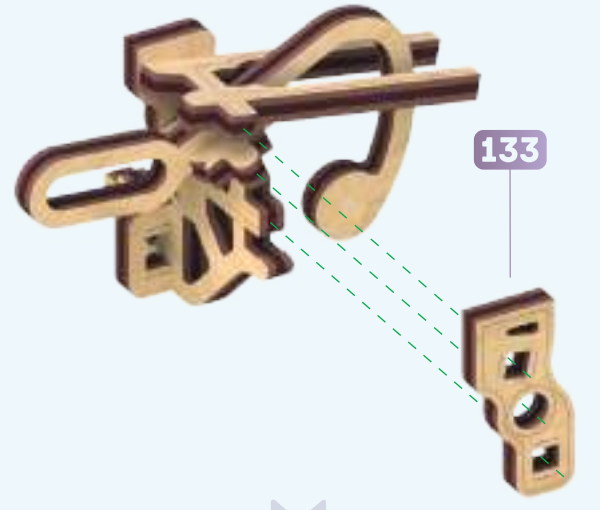
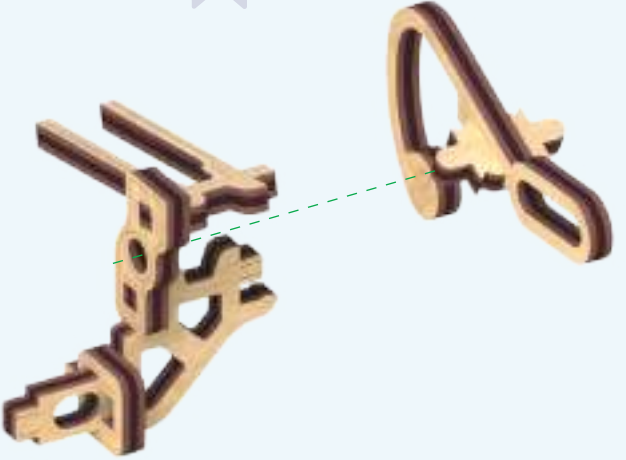
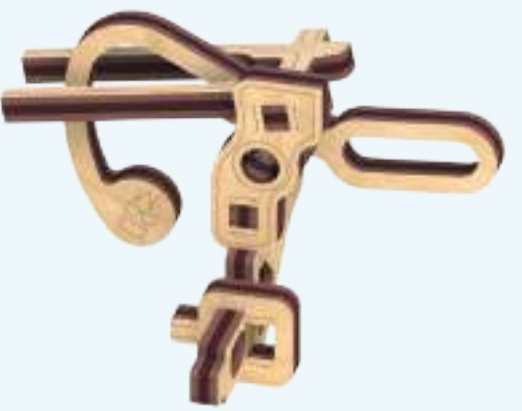

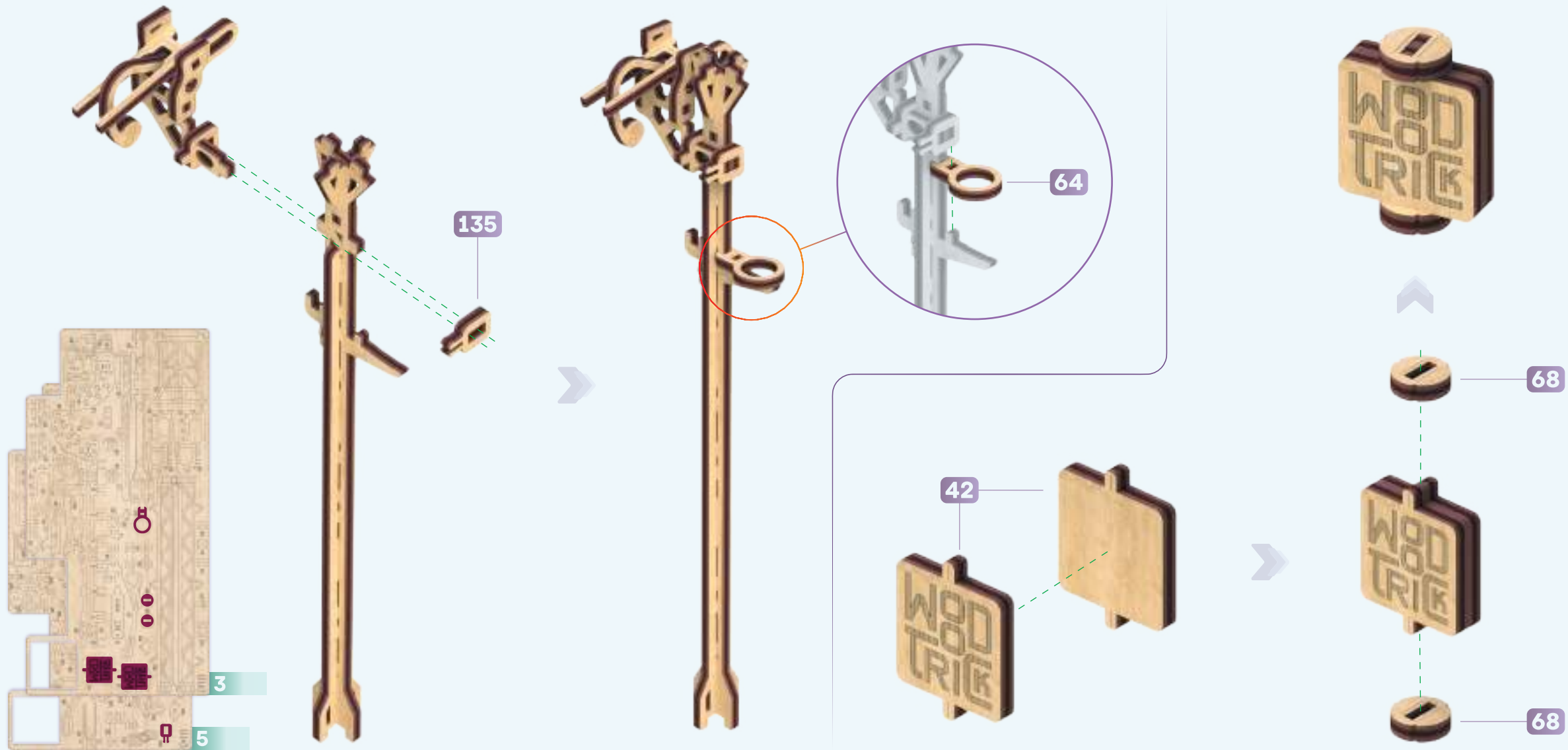

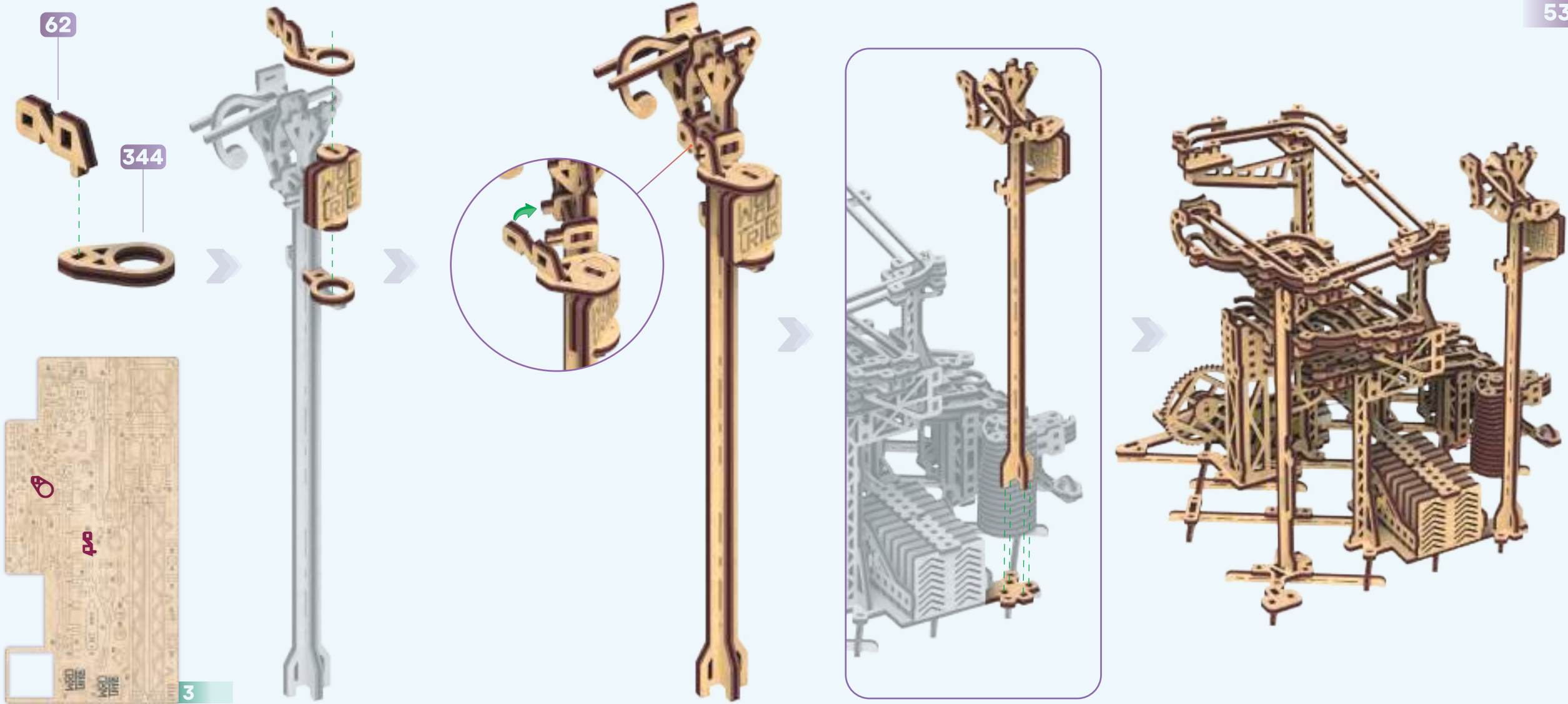

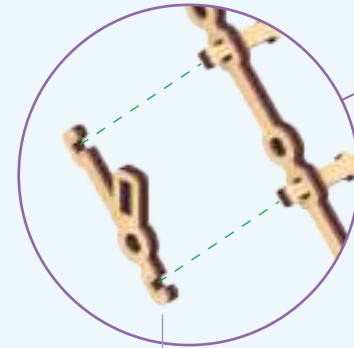
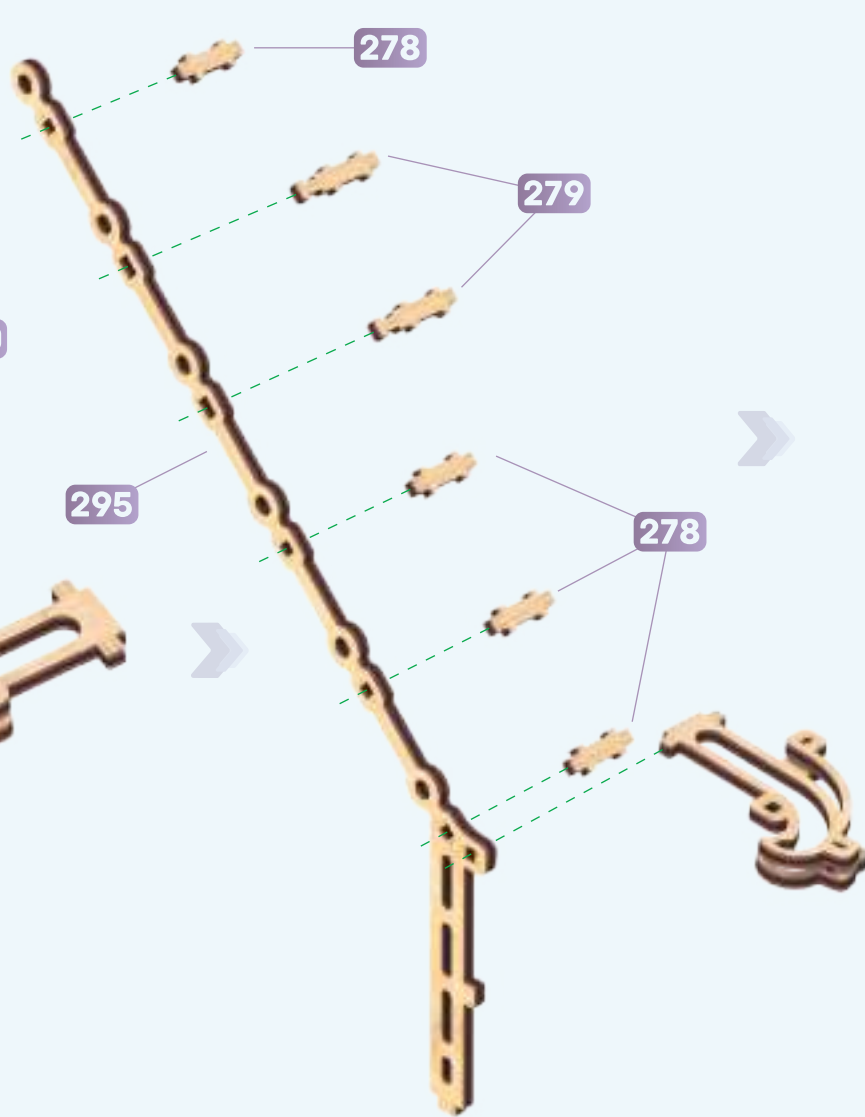
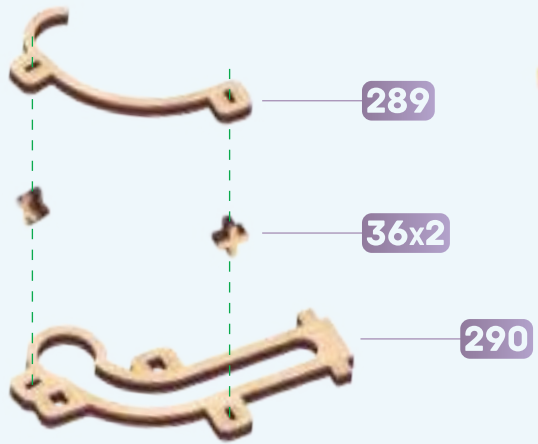
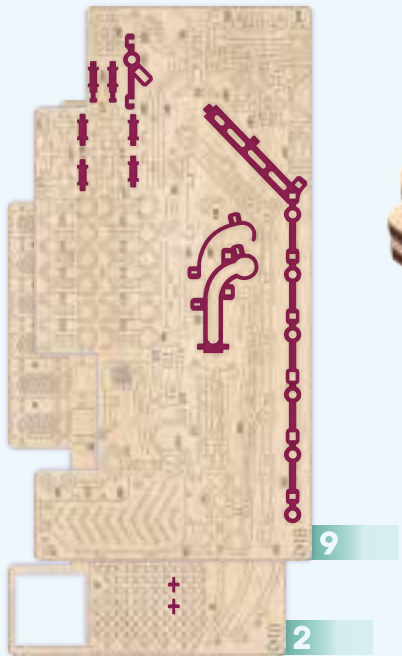

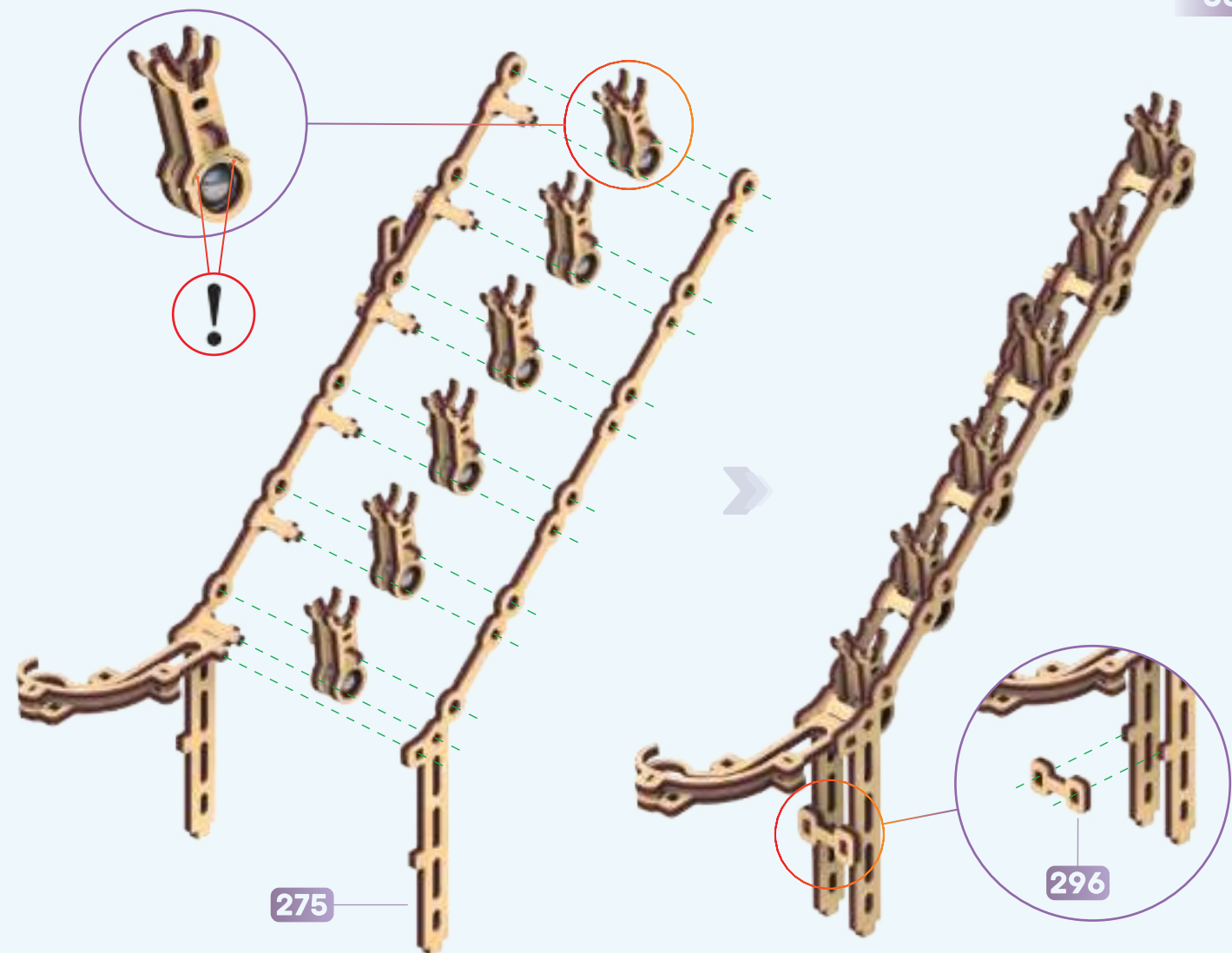
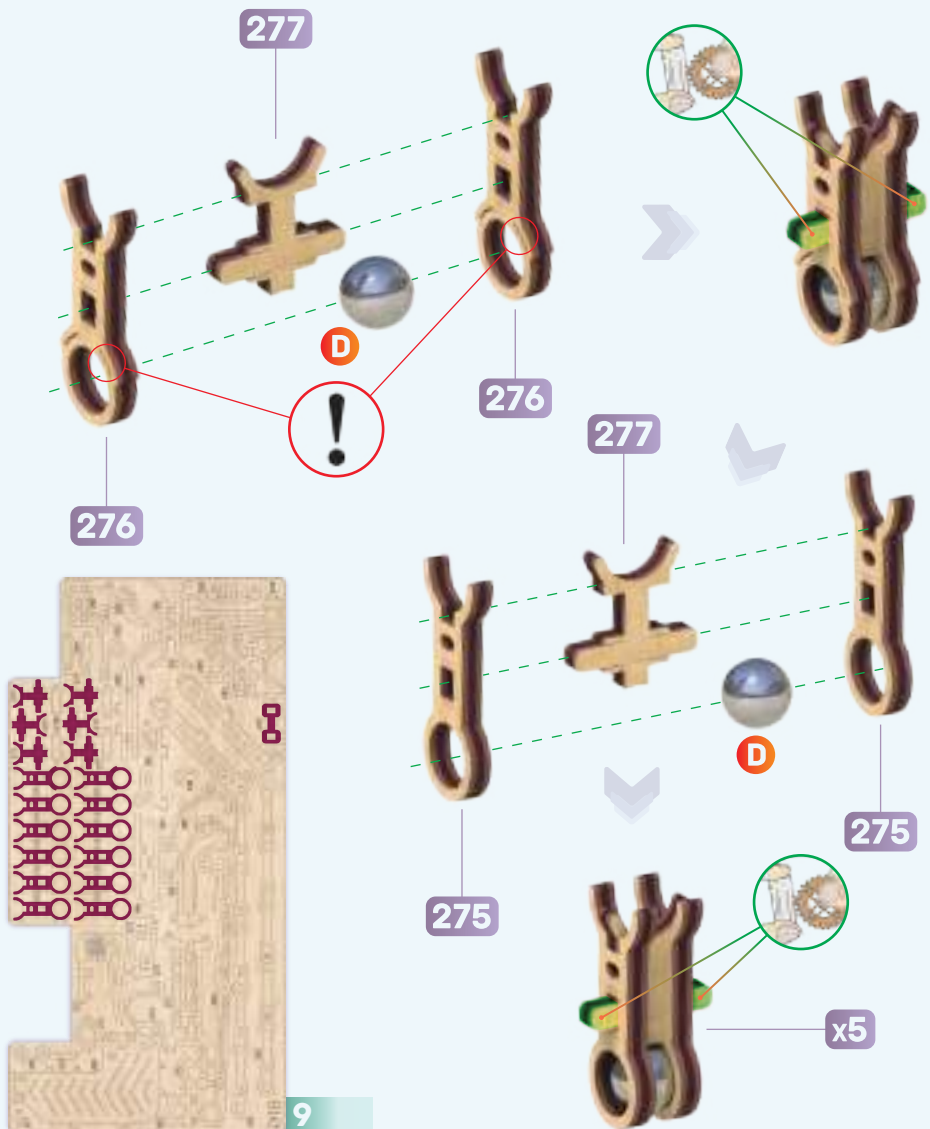

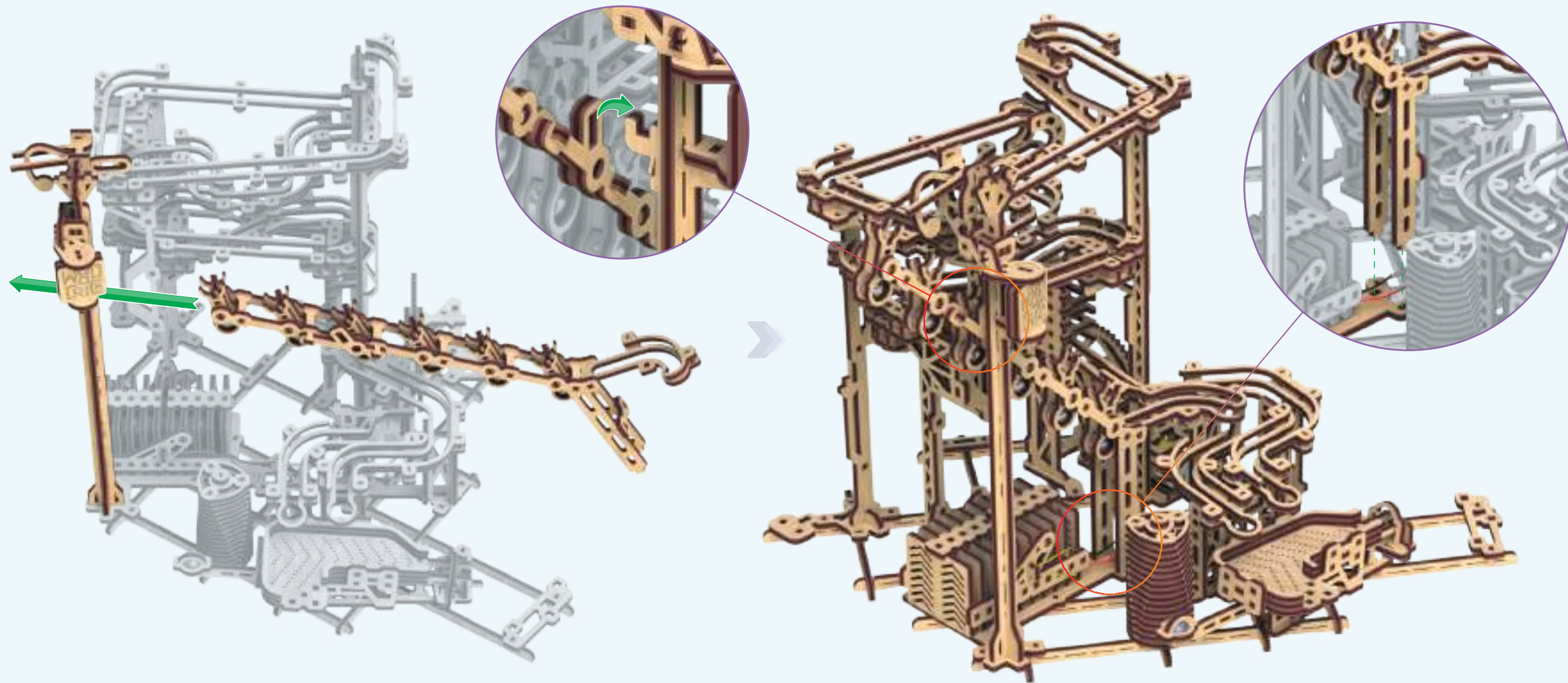

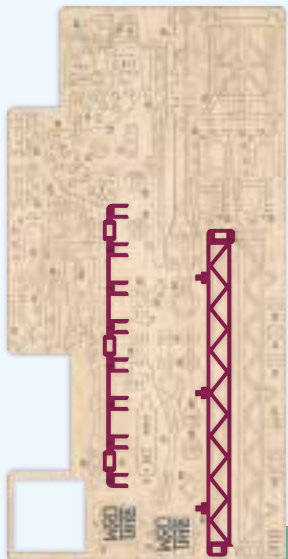

3

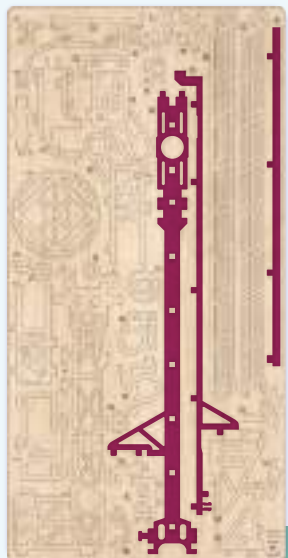

1

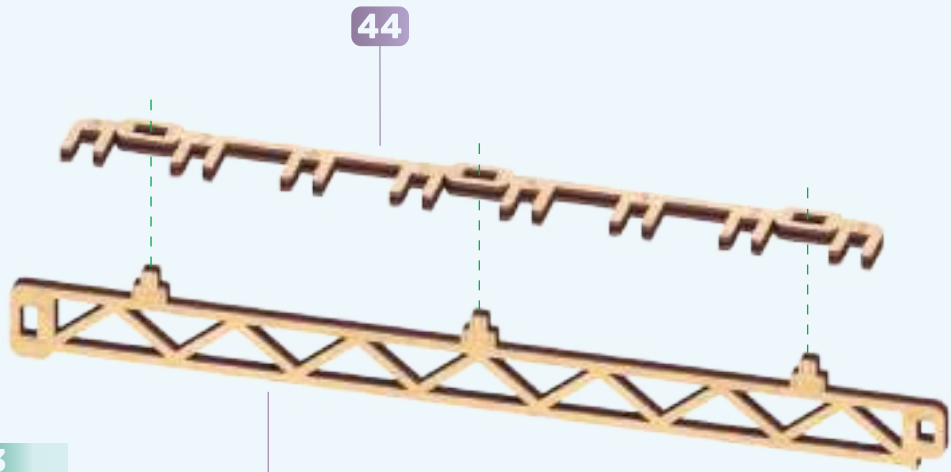

70

44



19

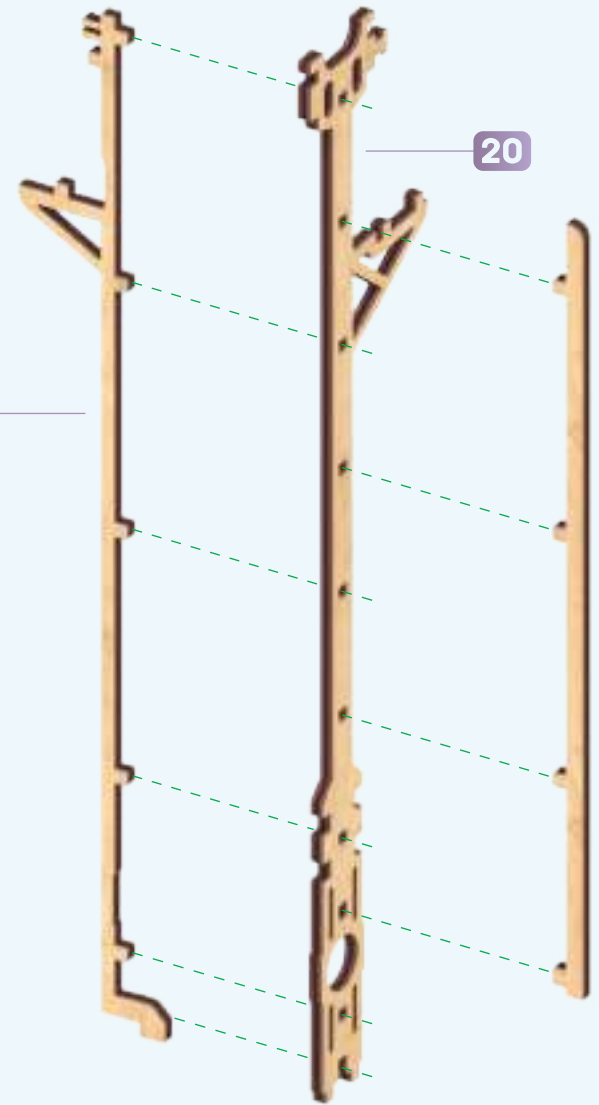

20

35



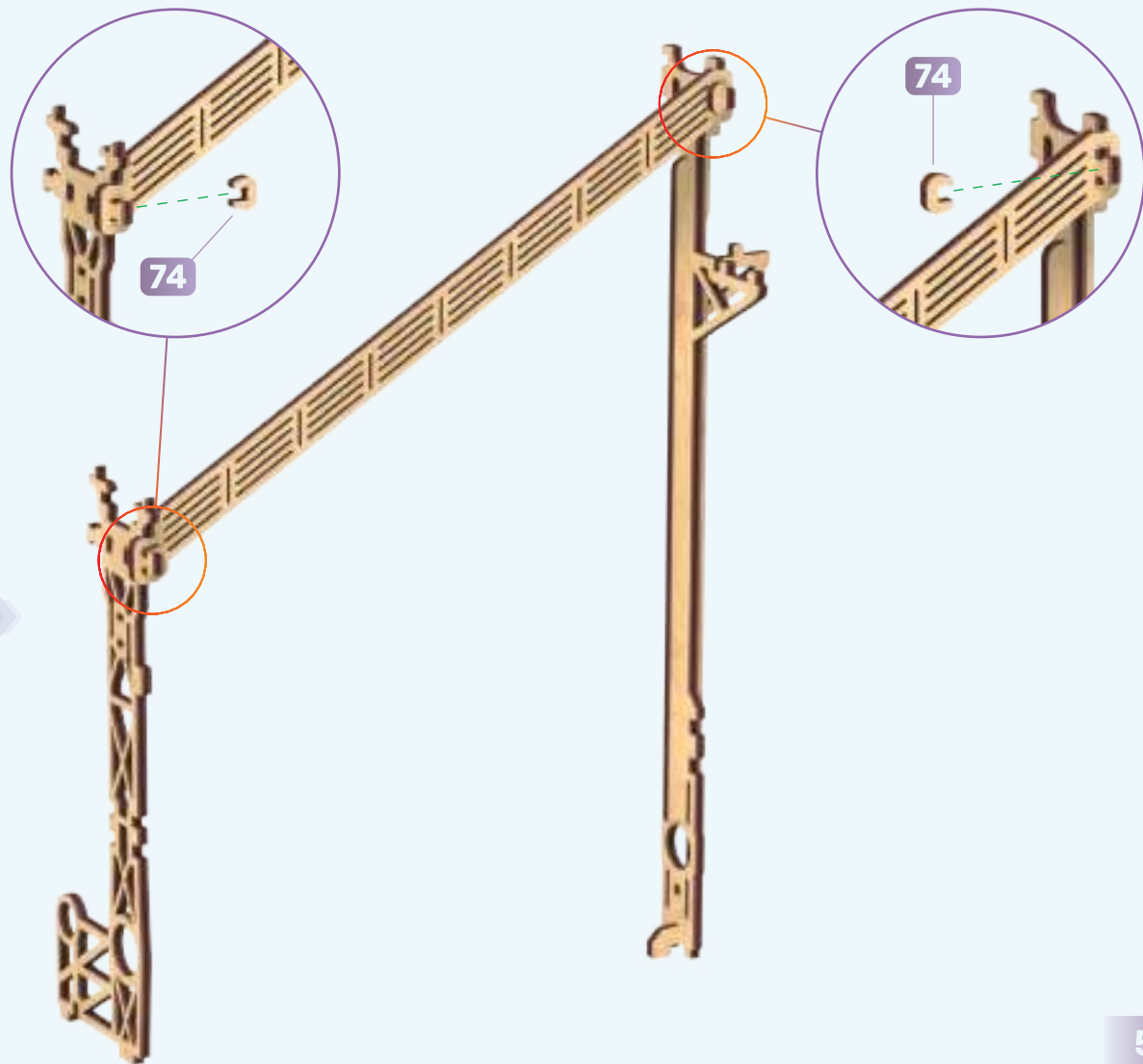
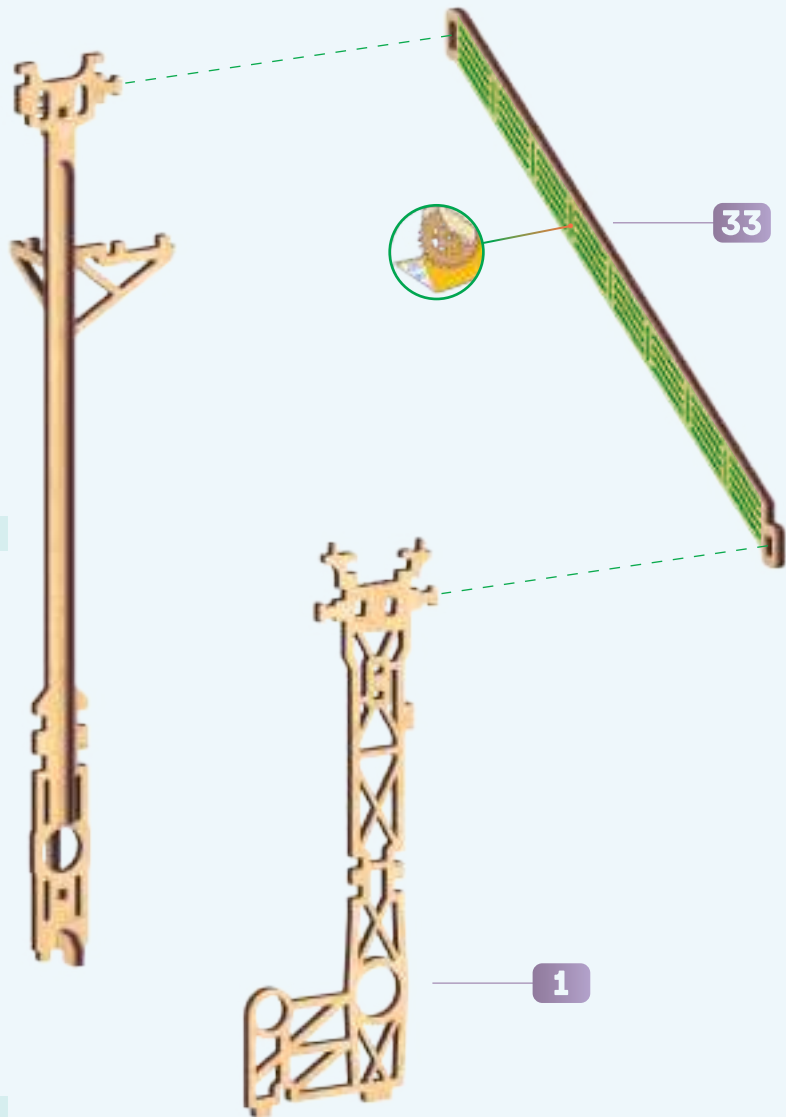
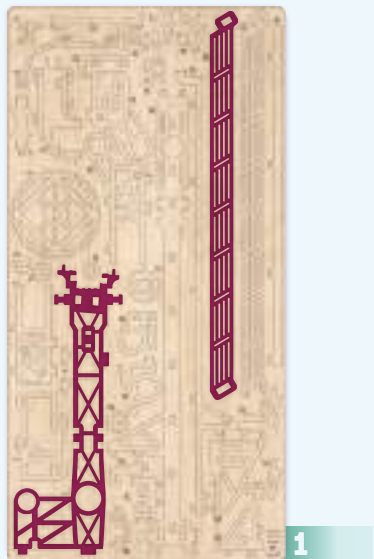

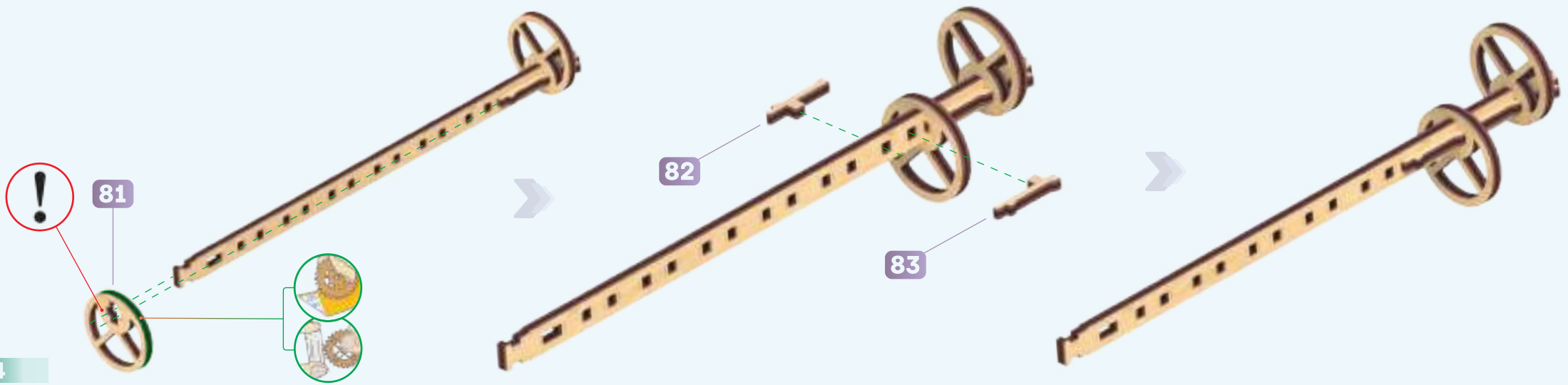
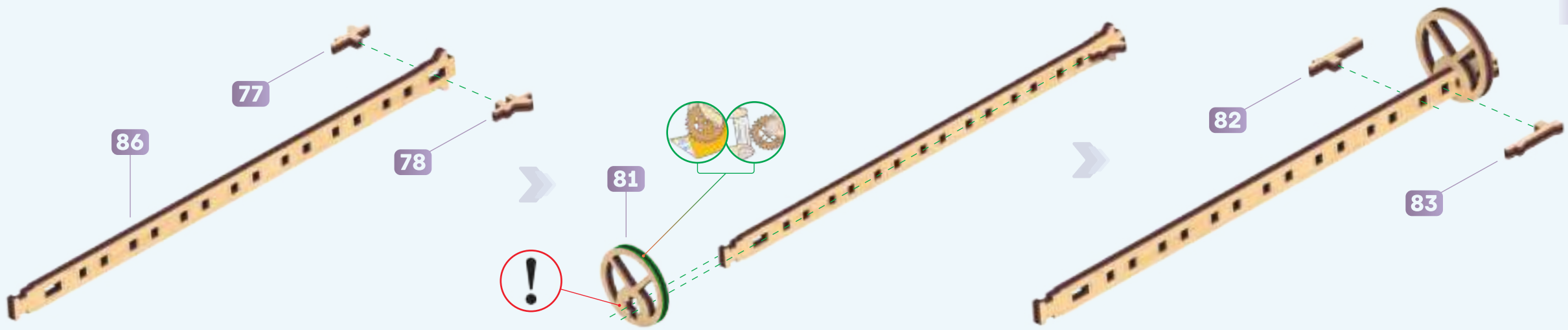

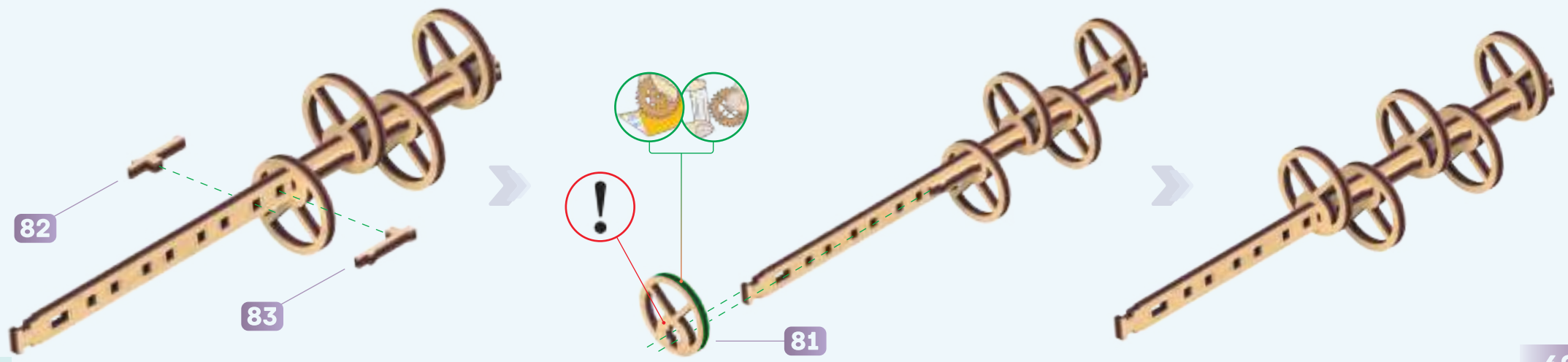
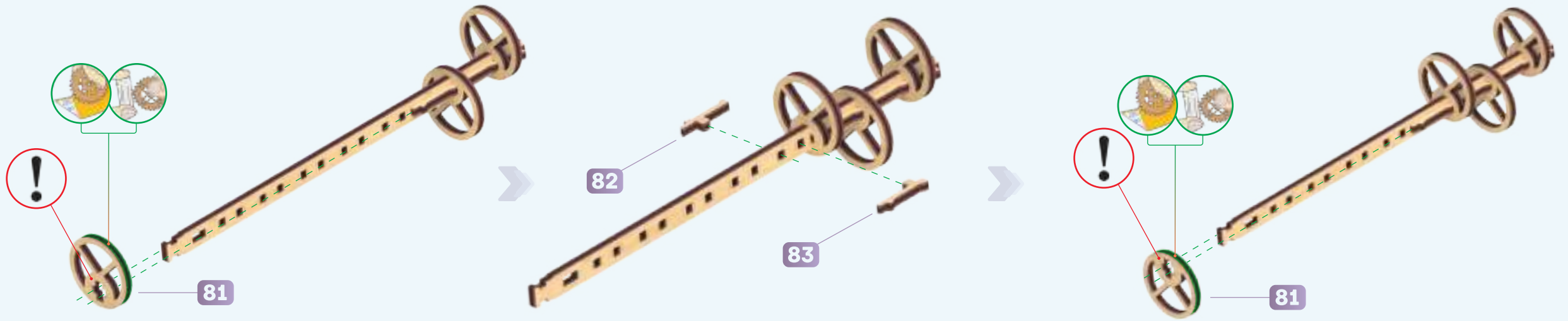

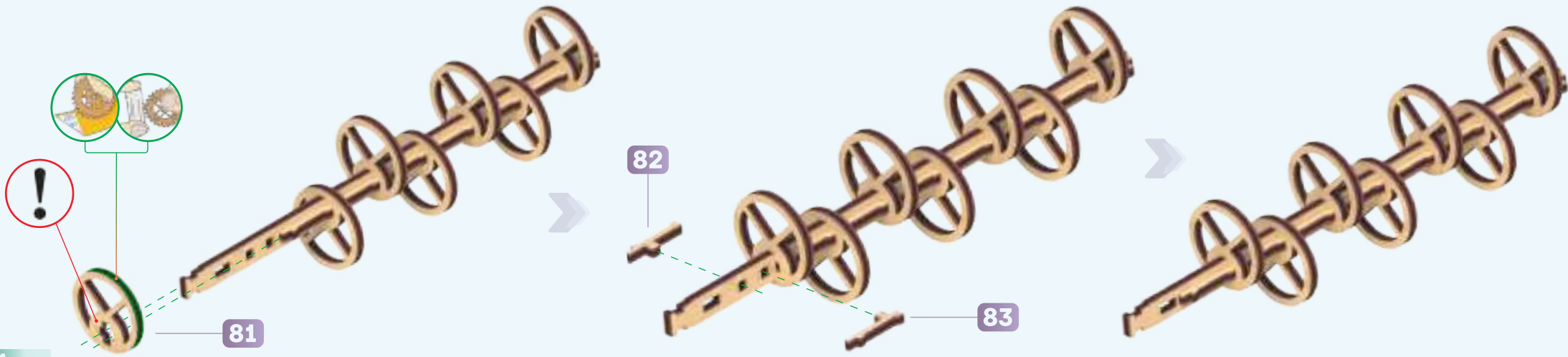
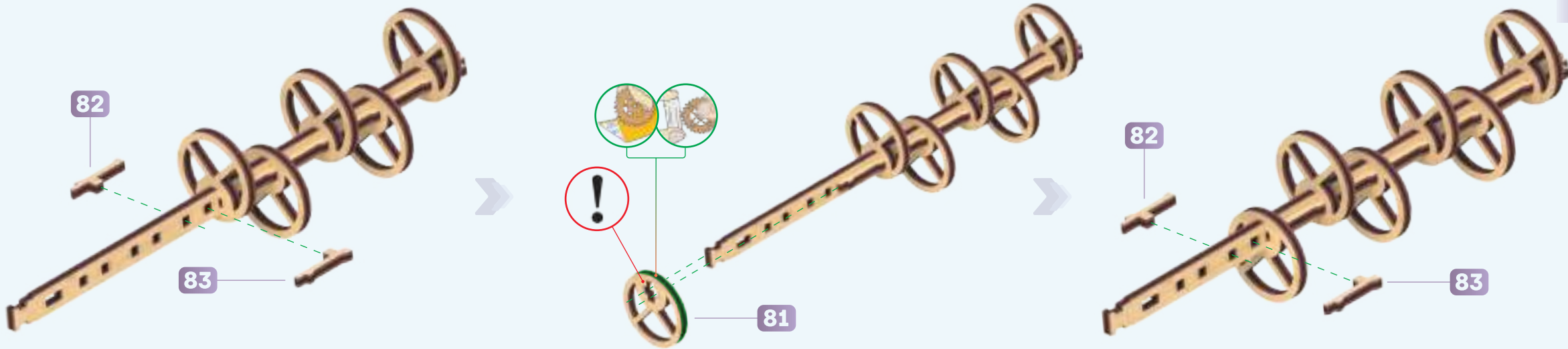

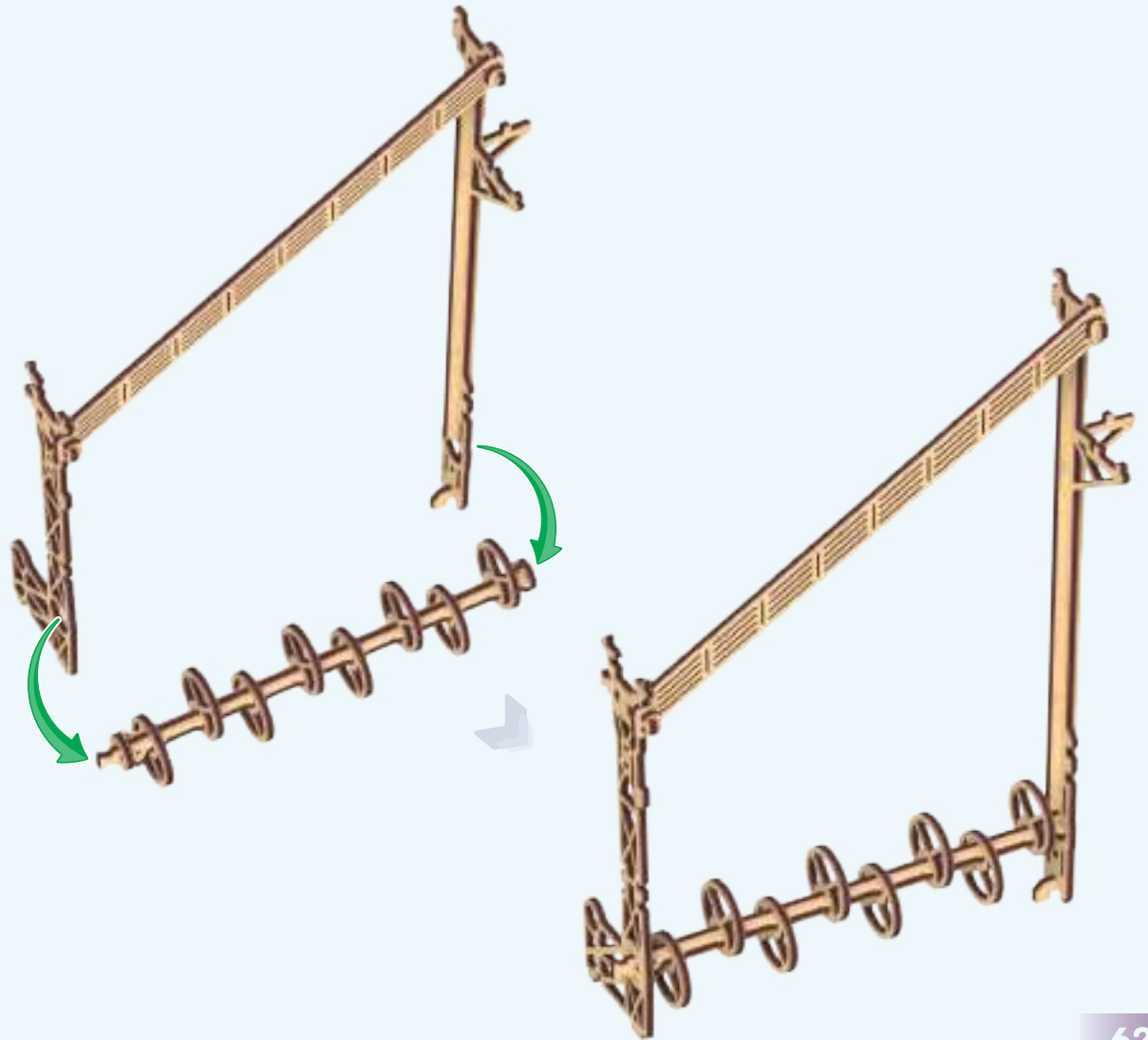
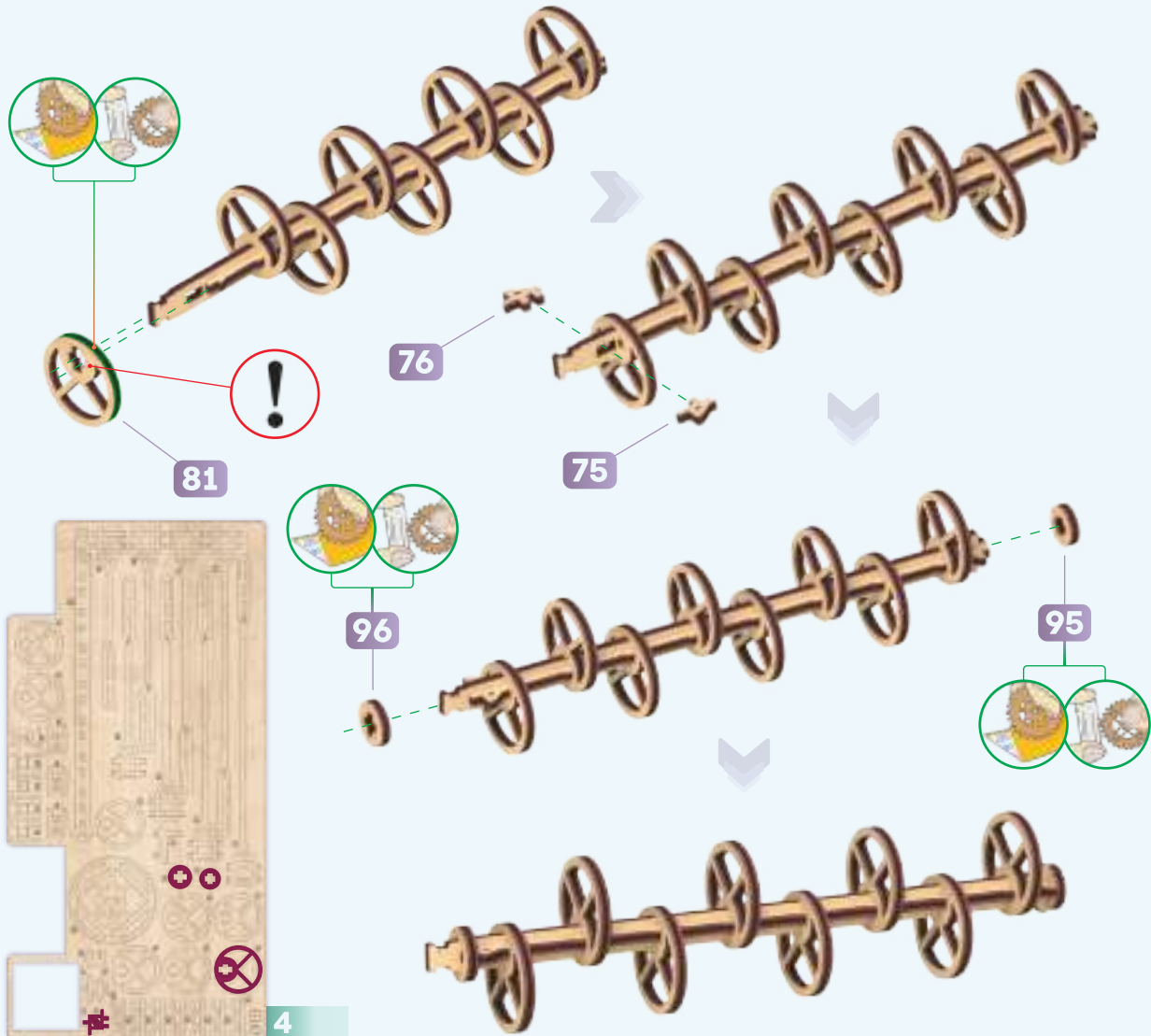

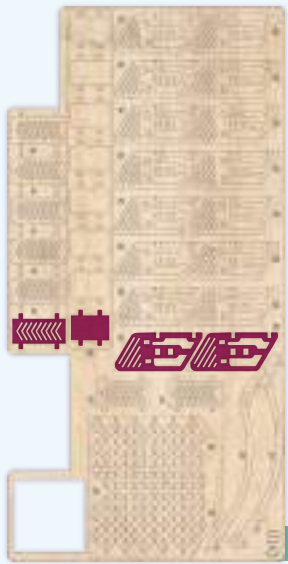

2

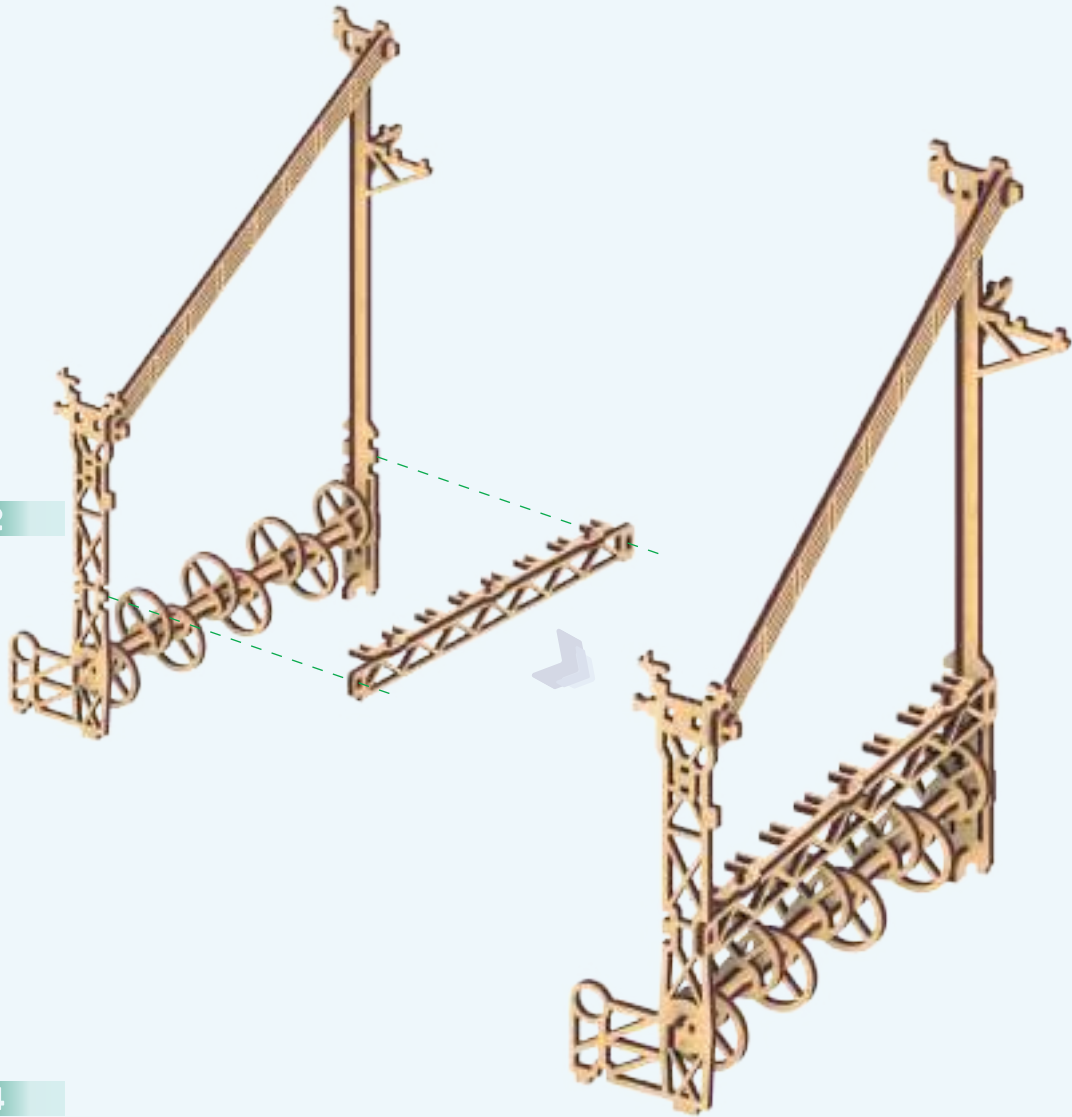

4

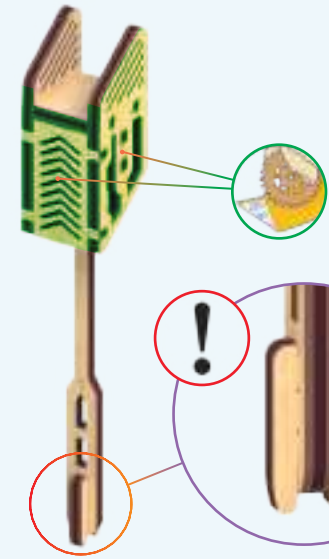
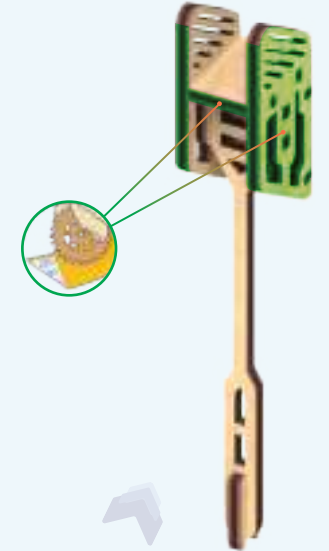
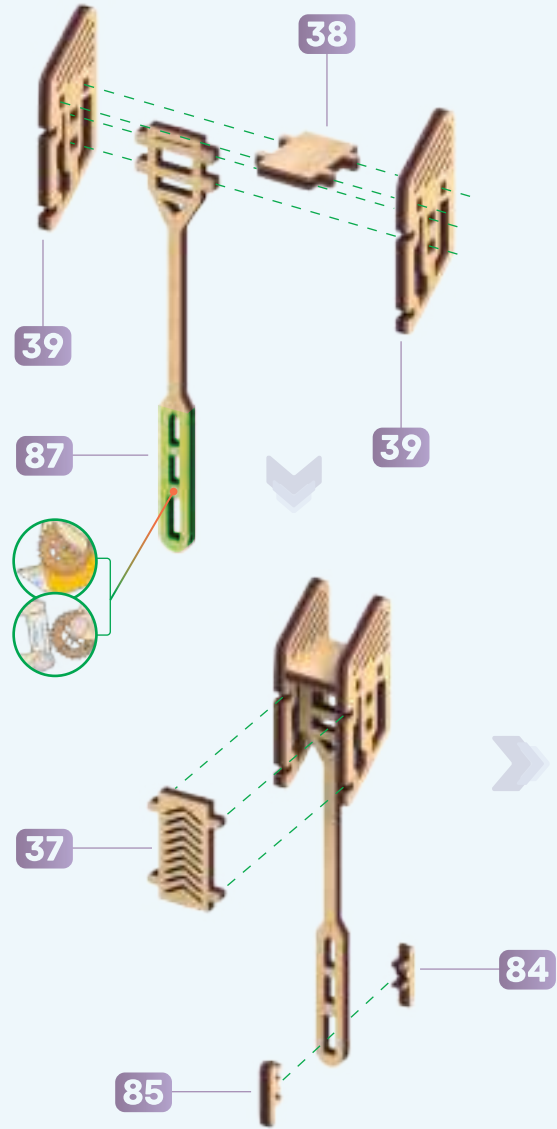

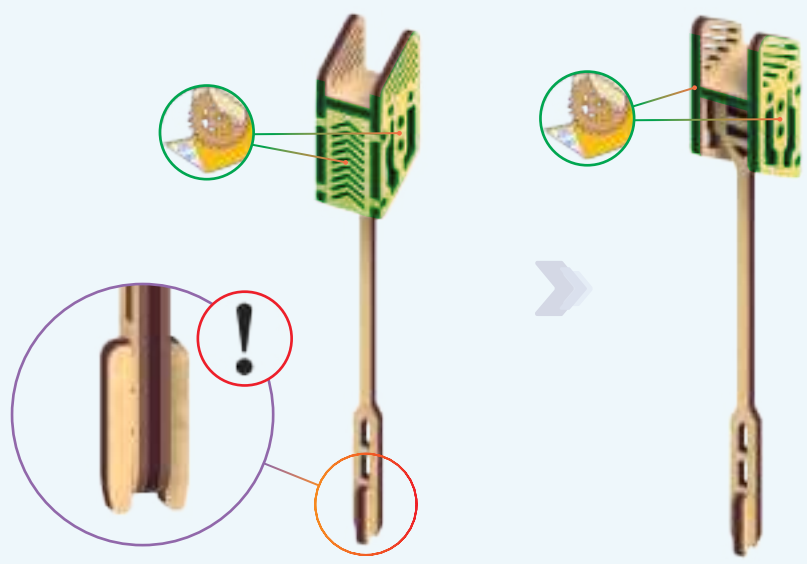
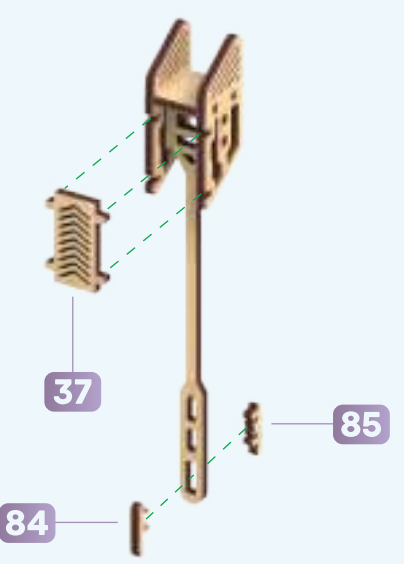
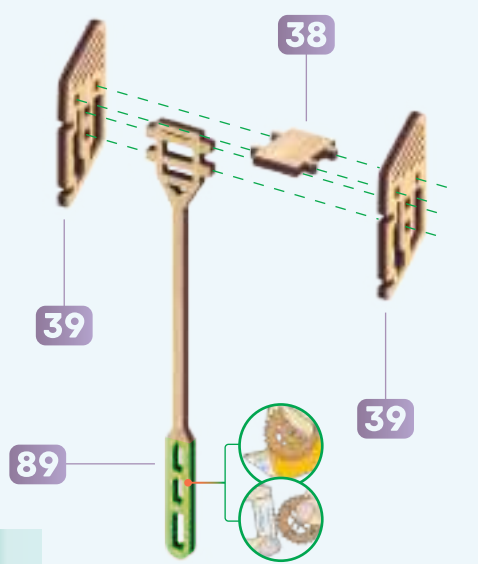
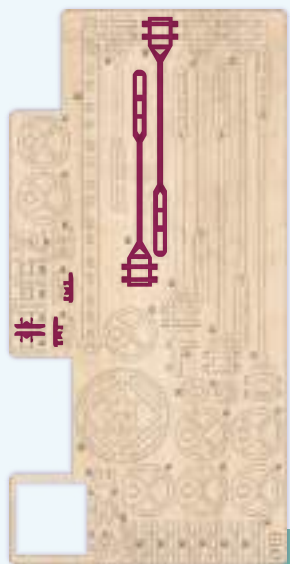
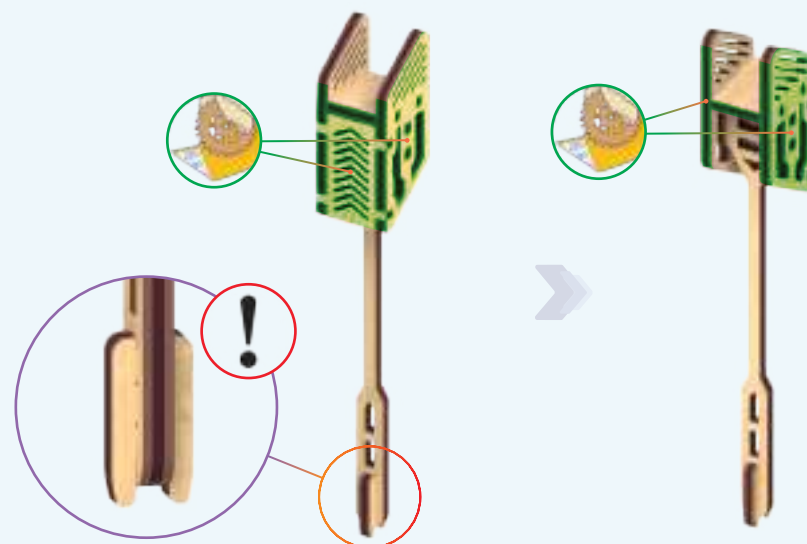
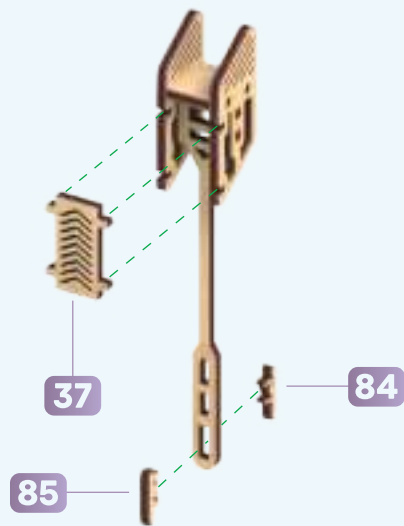
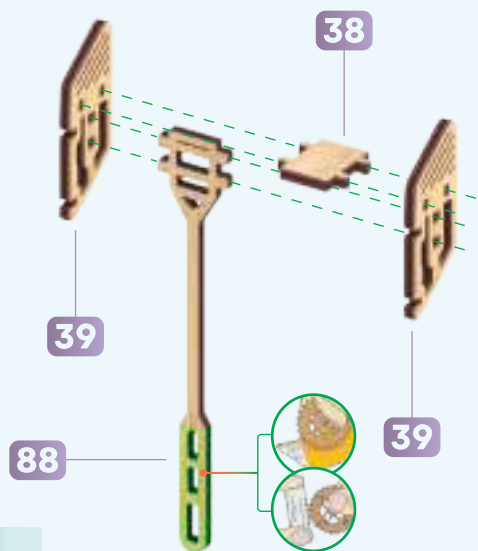
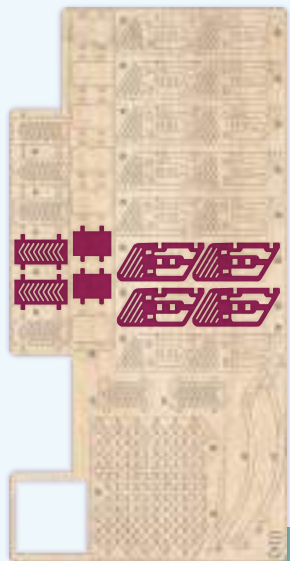



2

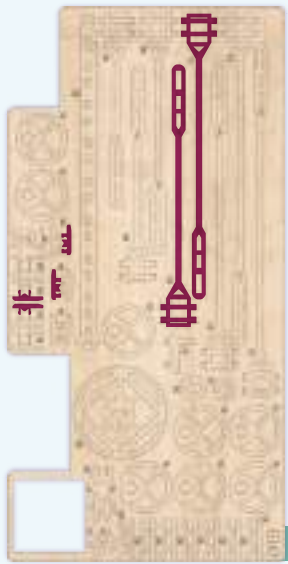
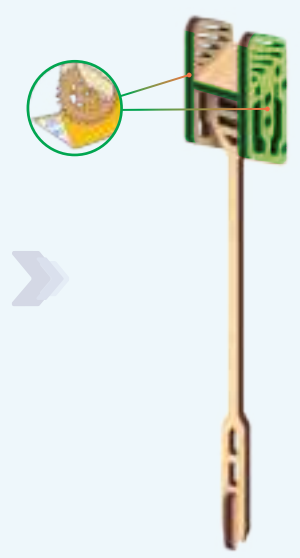
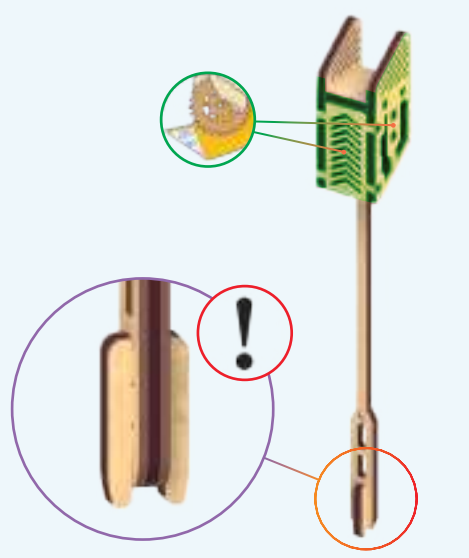
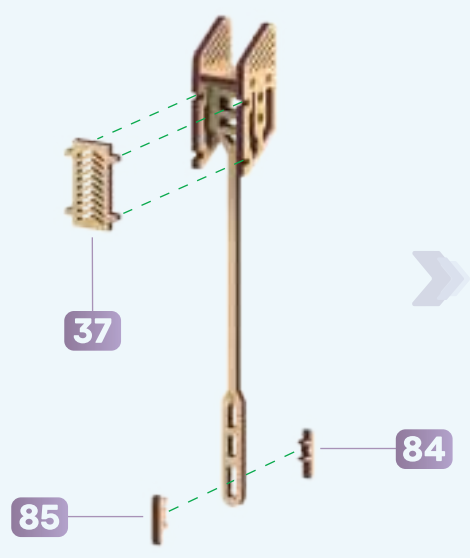
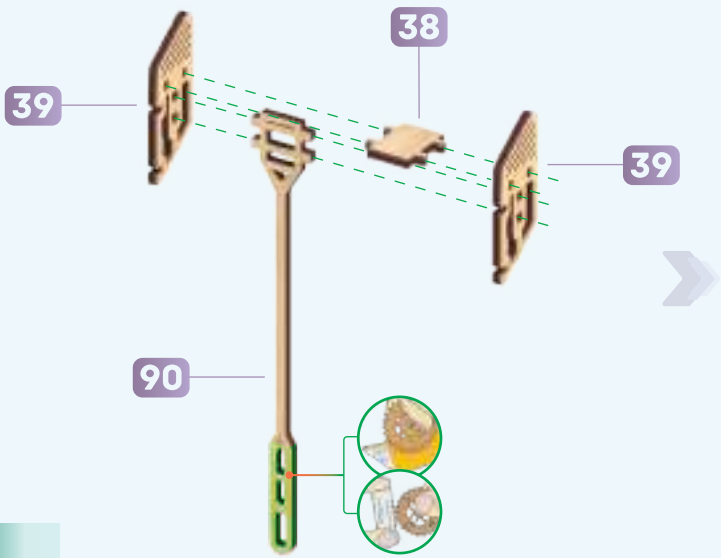

4

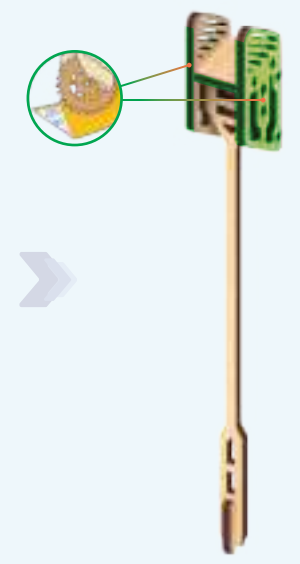
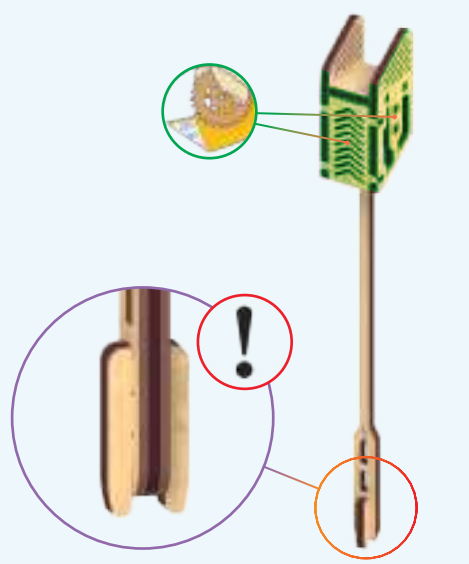
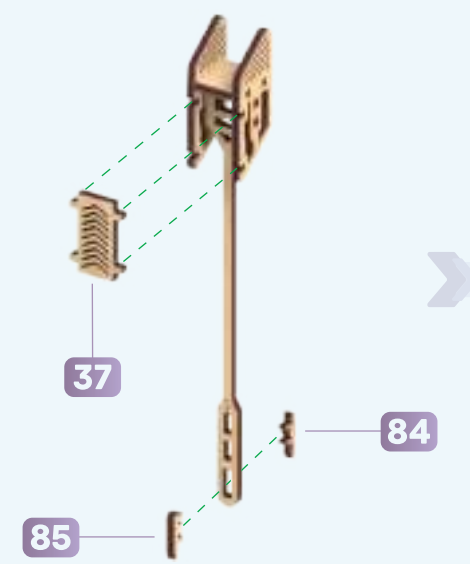
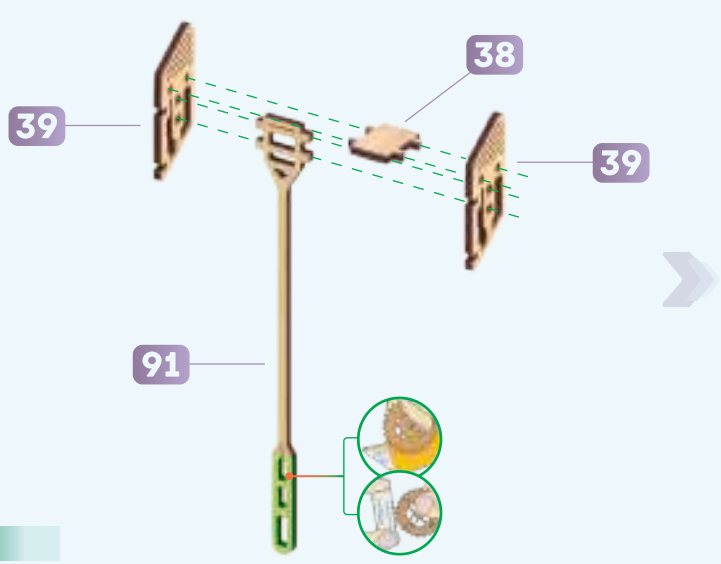

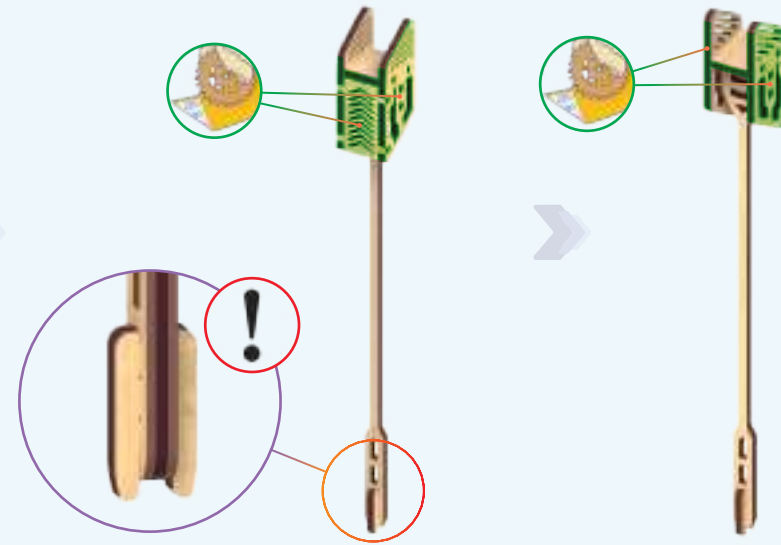
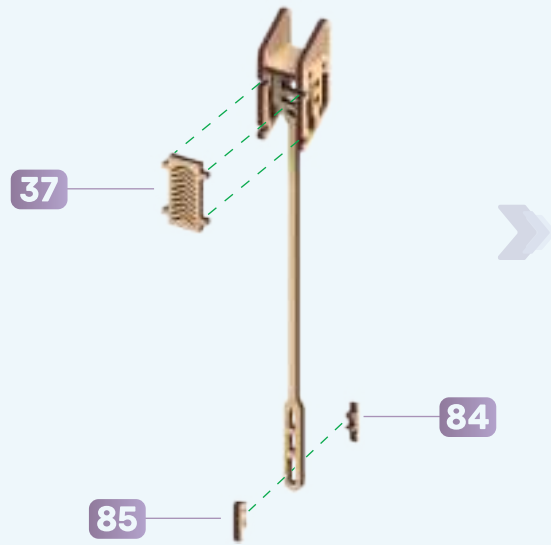
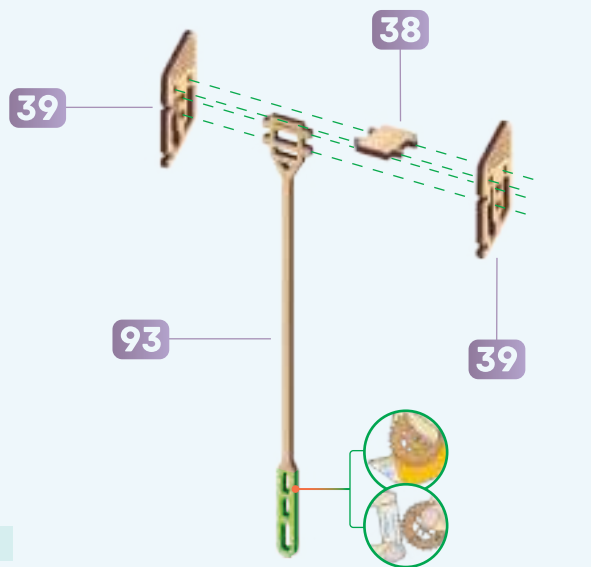
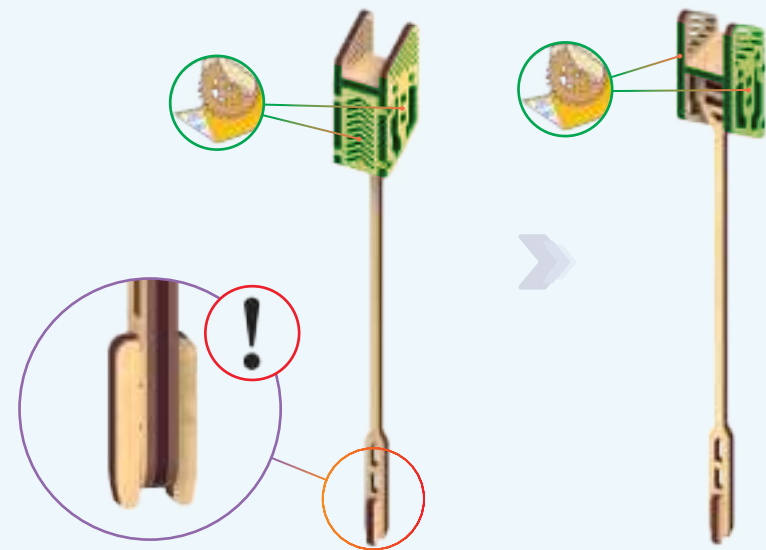
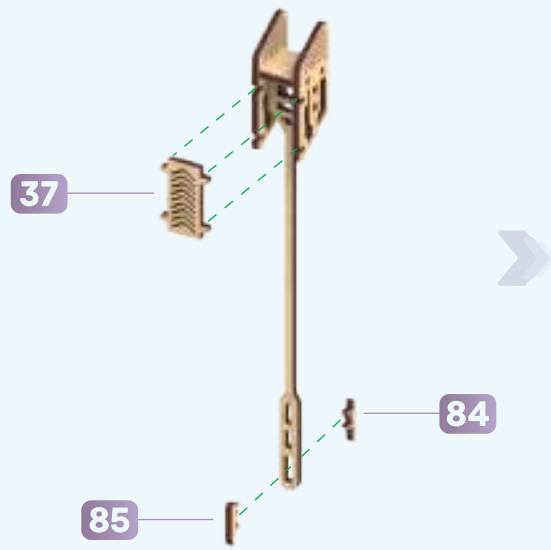
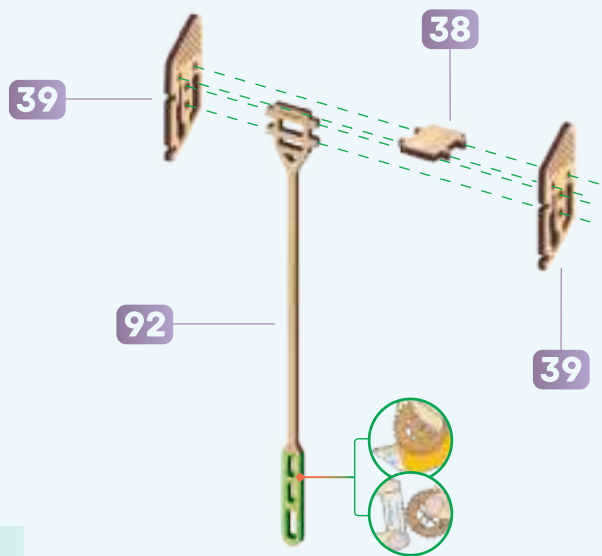

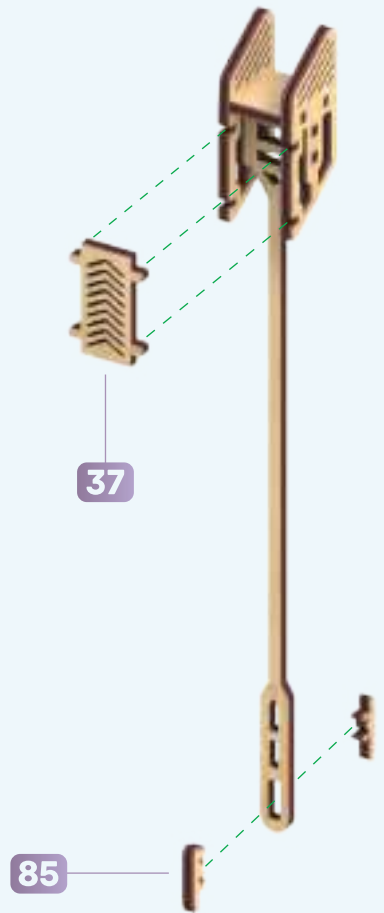
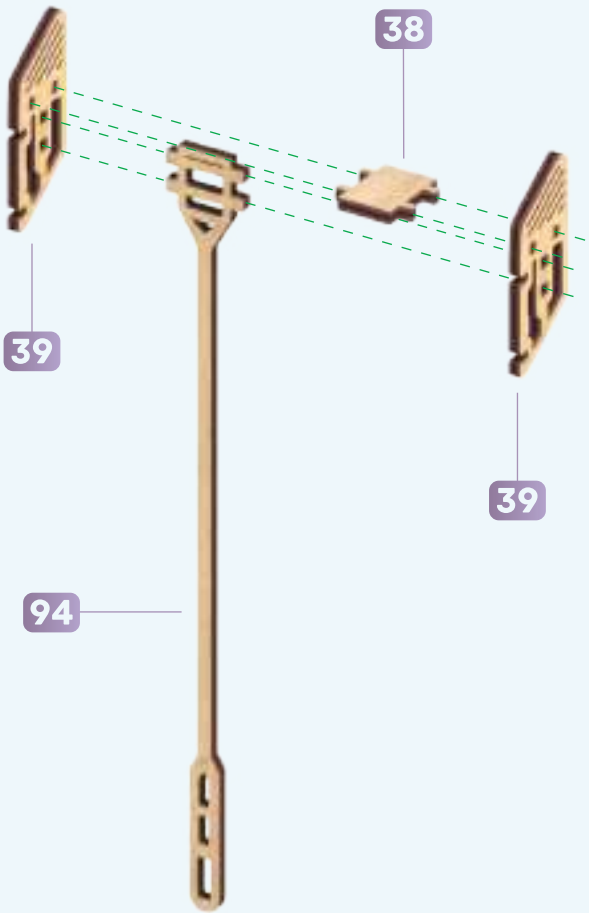

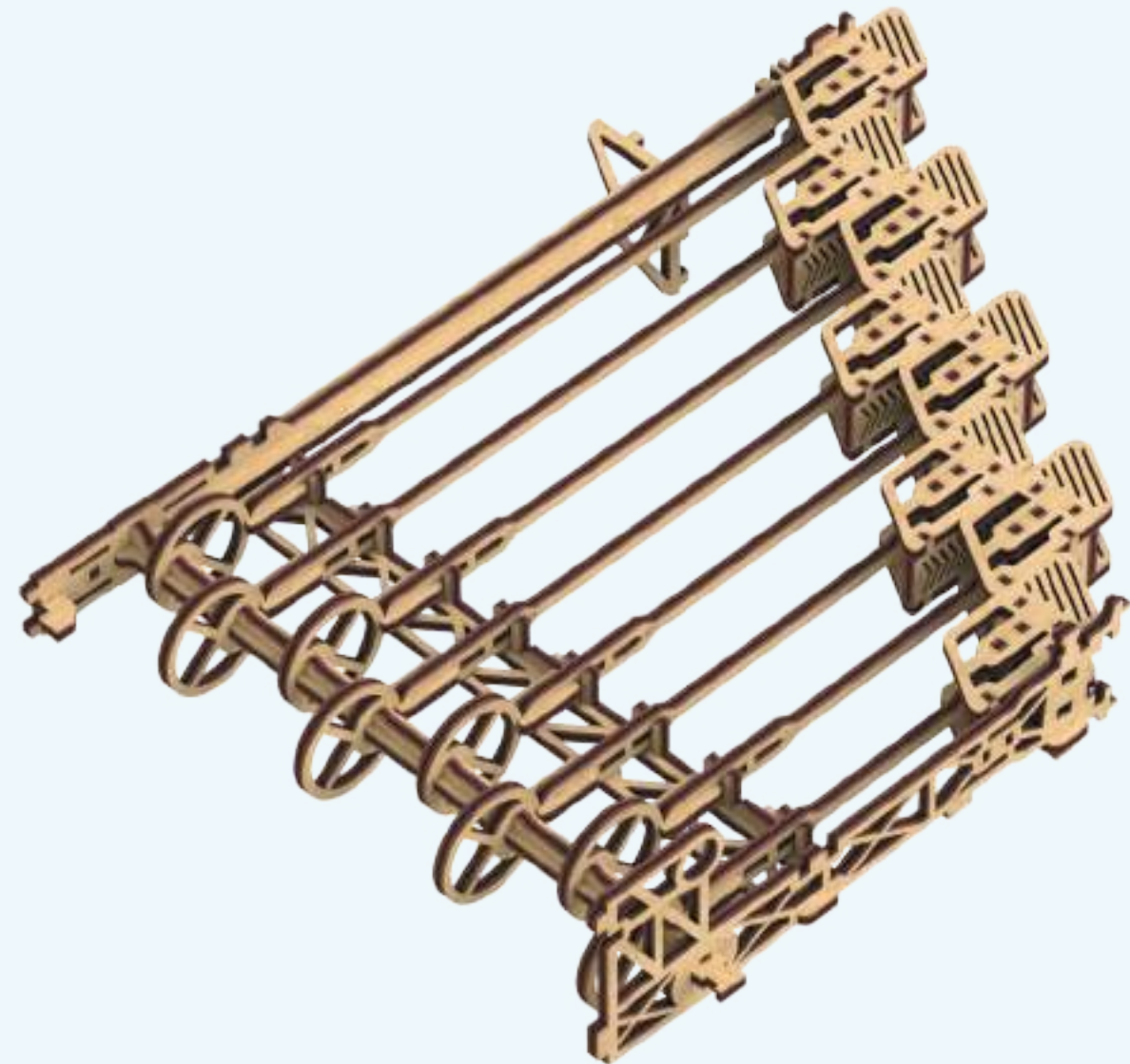
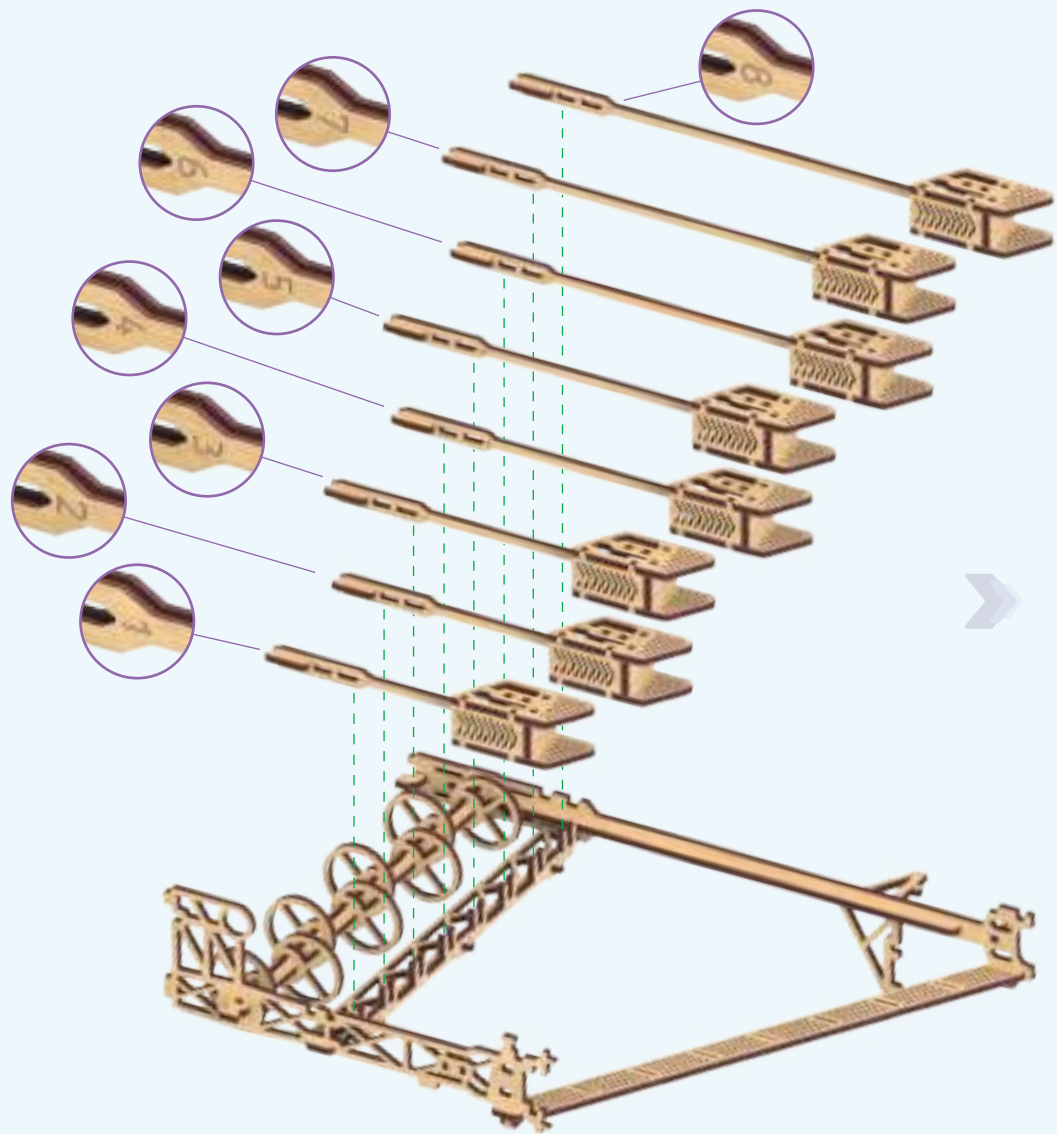

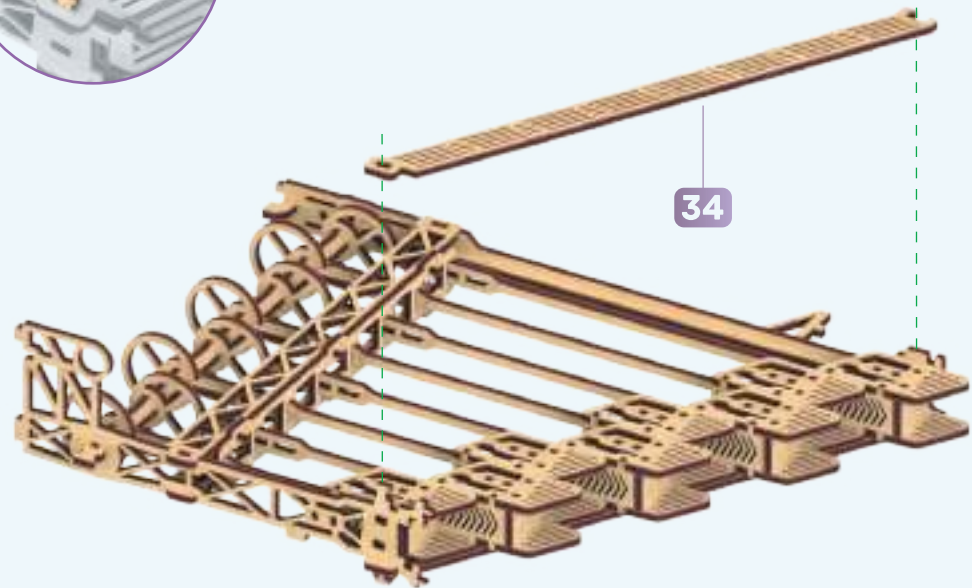
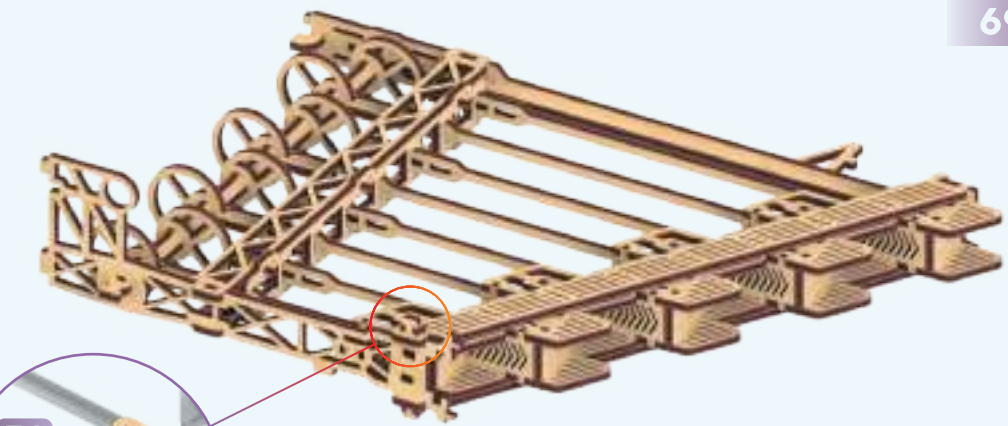
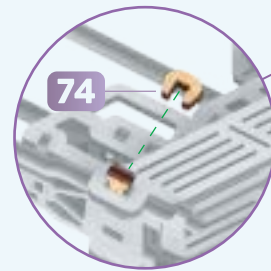
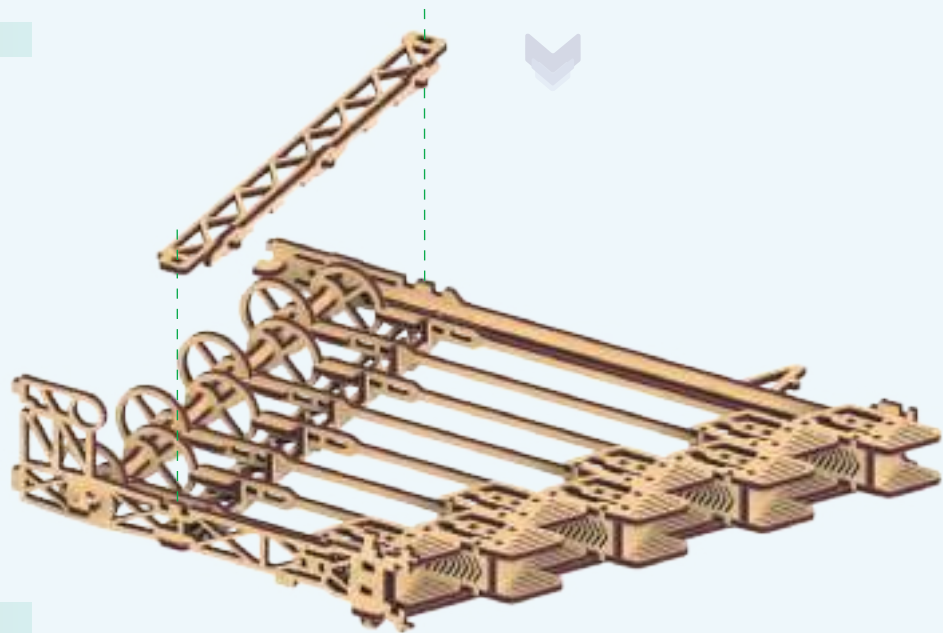
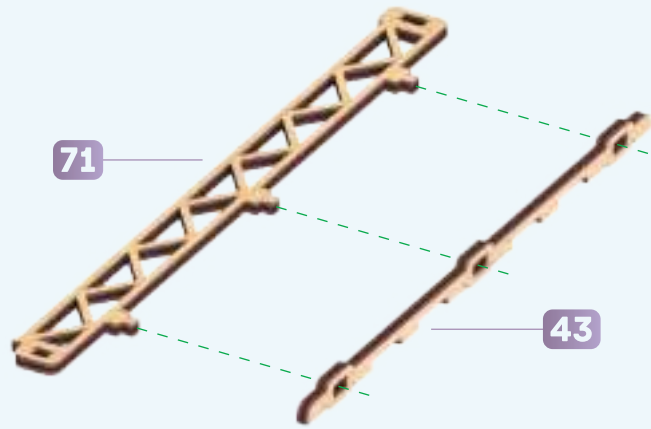
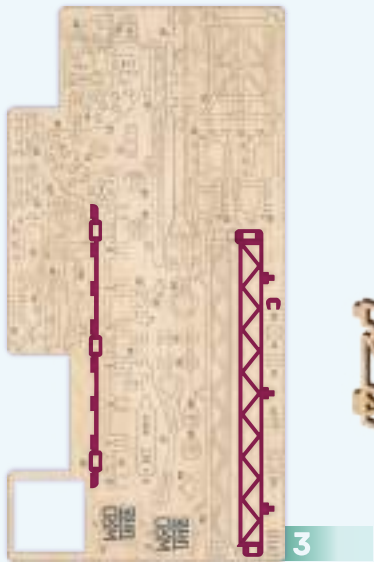
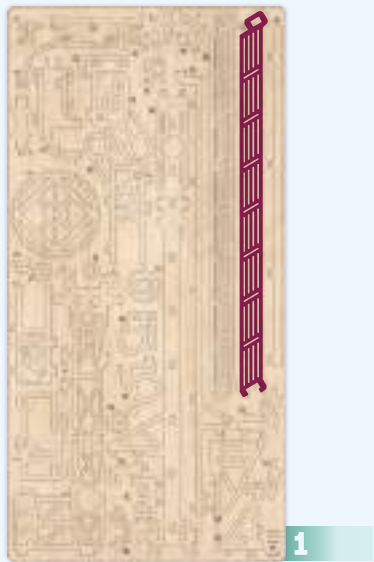

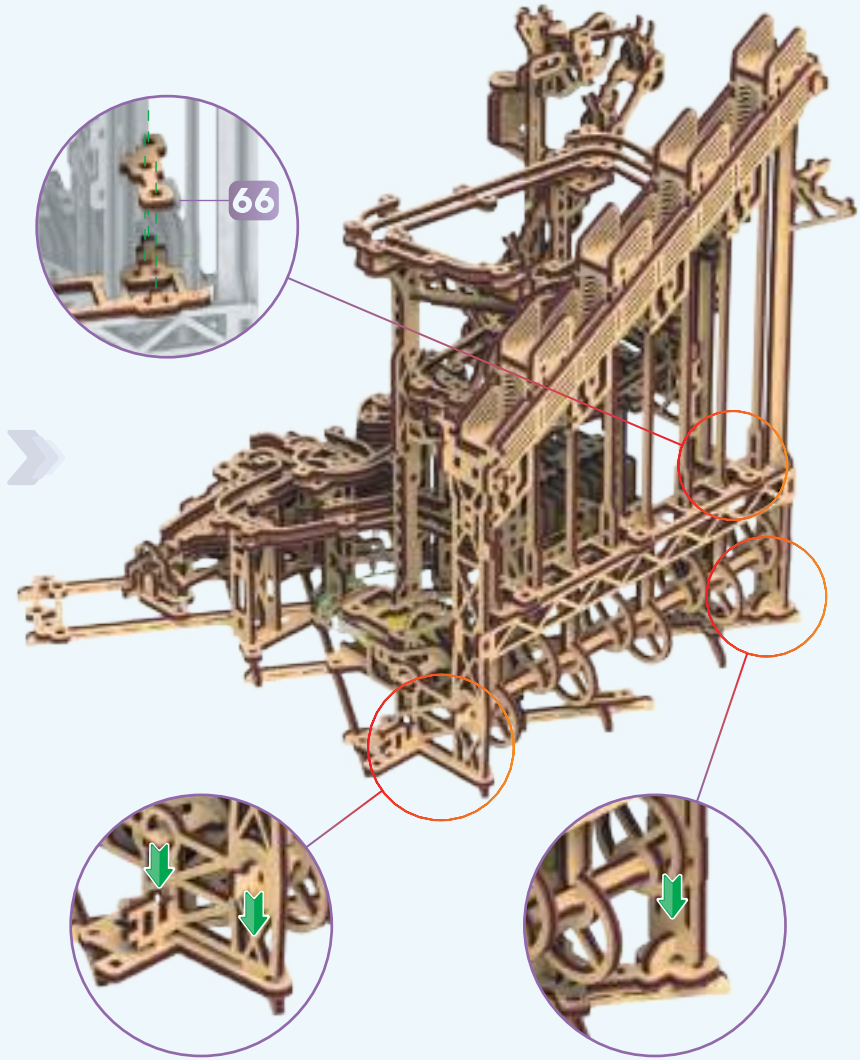
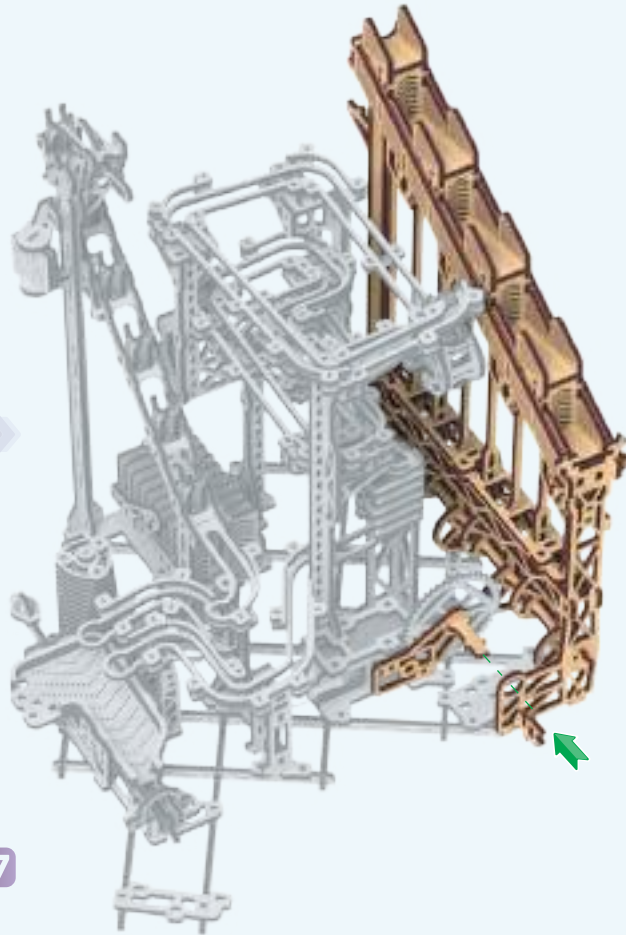
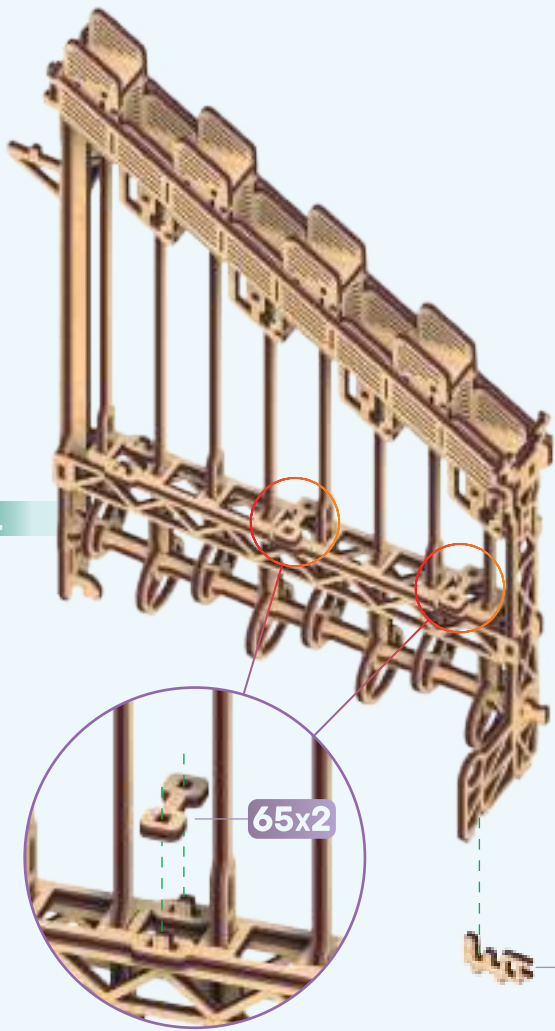
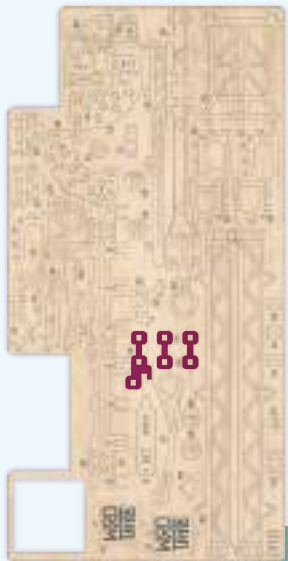



1

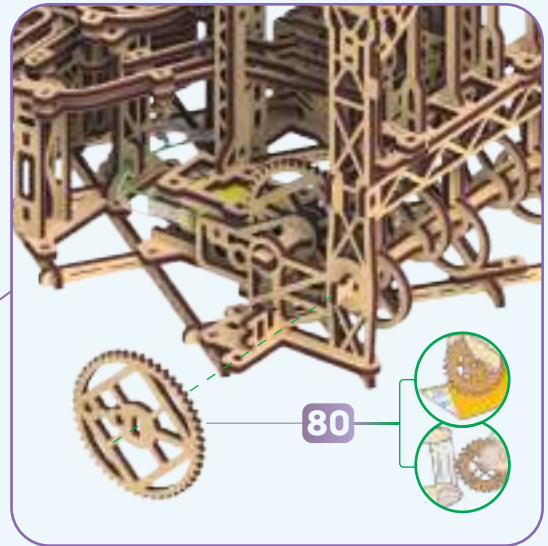
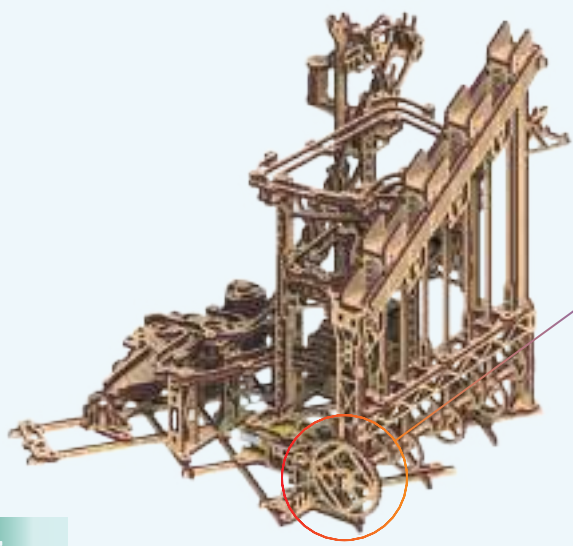

80

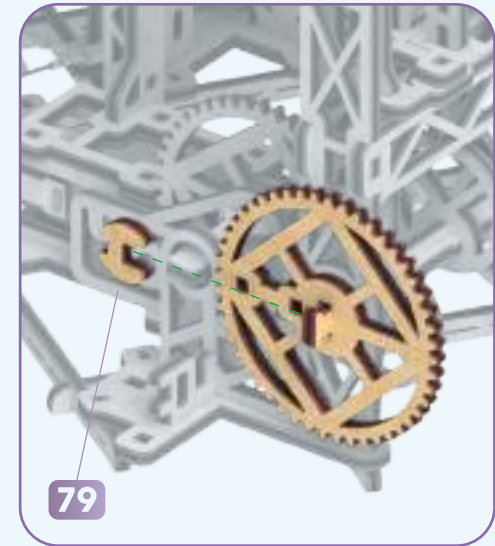

79

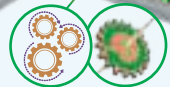
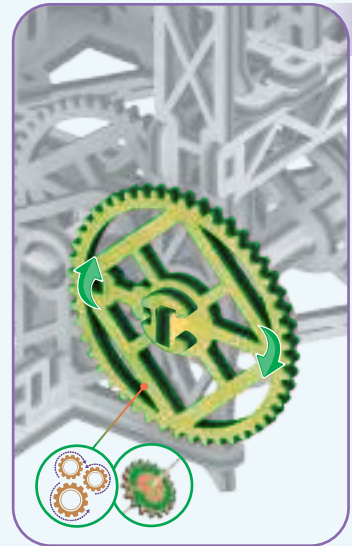

4

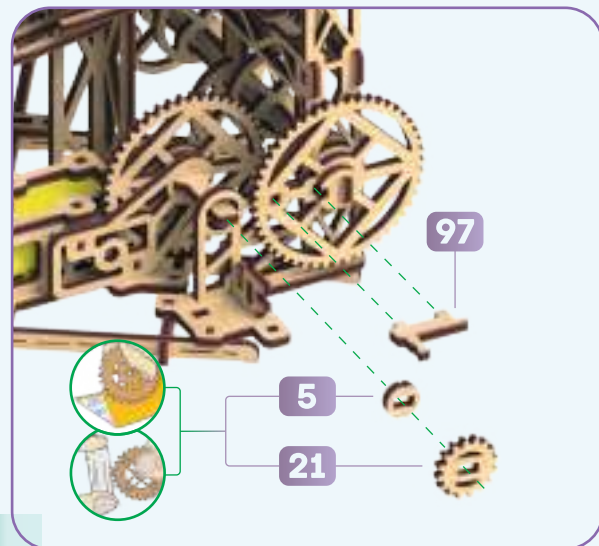

97

5

21

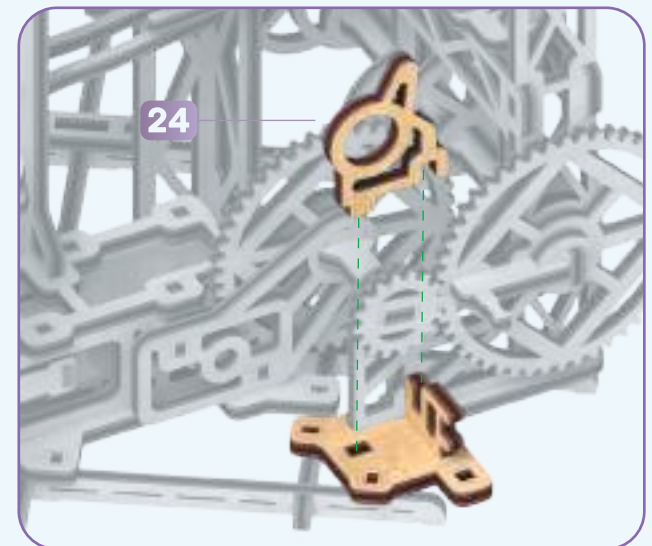

24





11

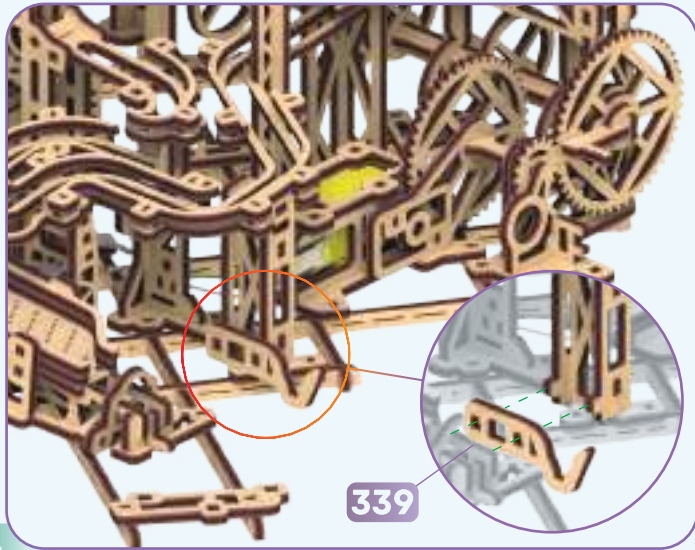

339

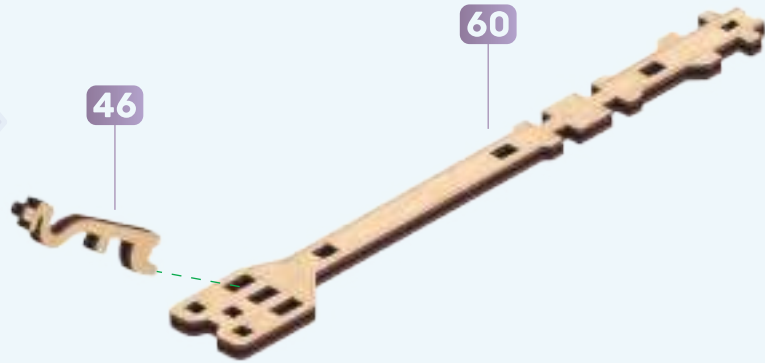

46

60

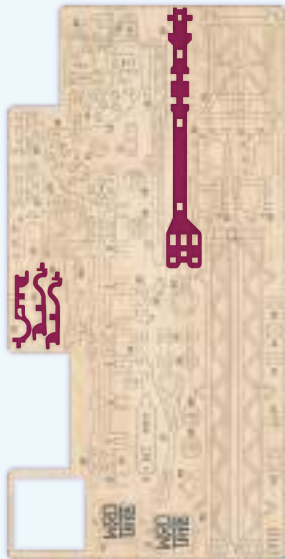
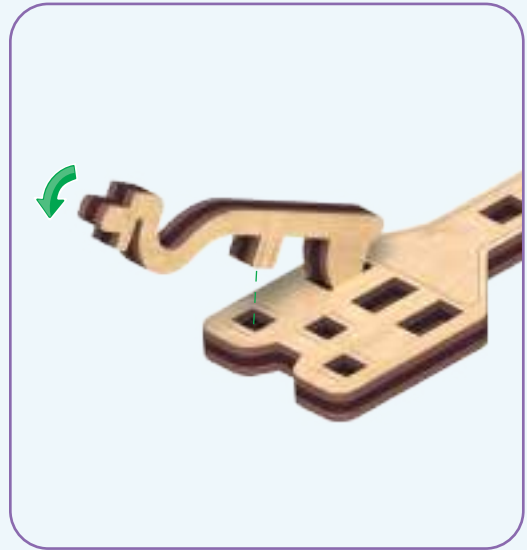

3



45



46

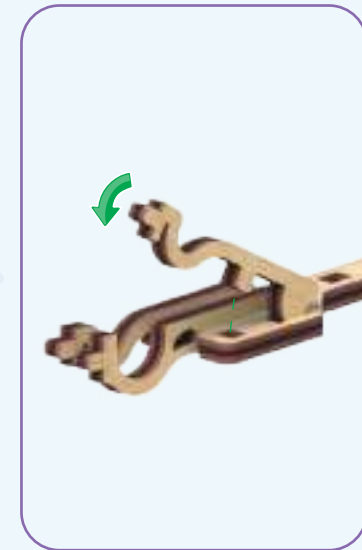

72

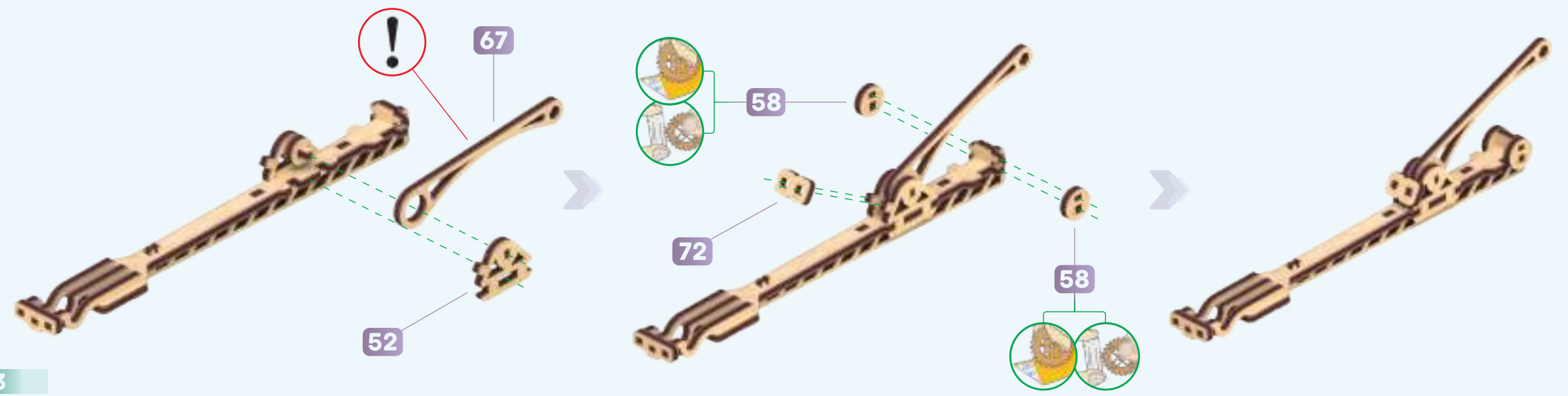
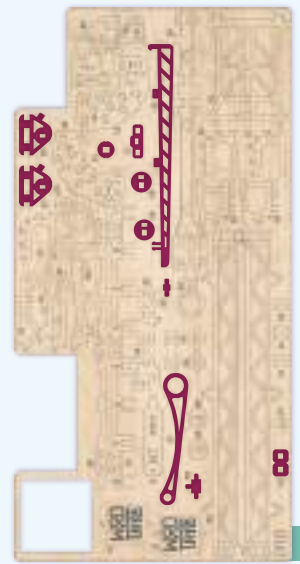
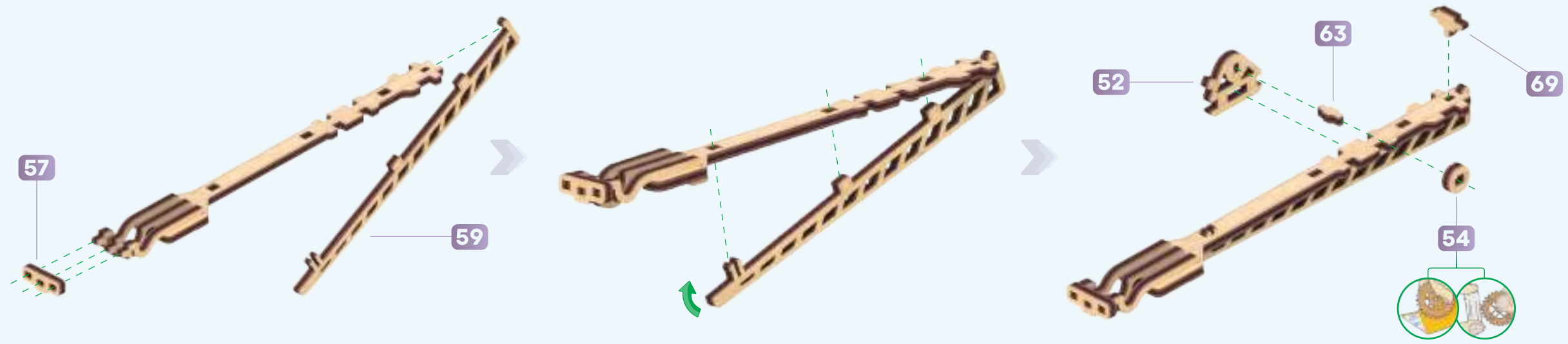

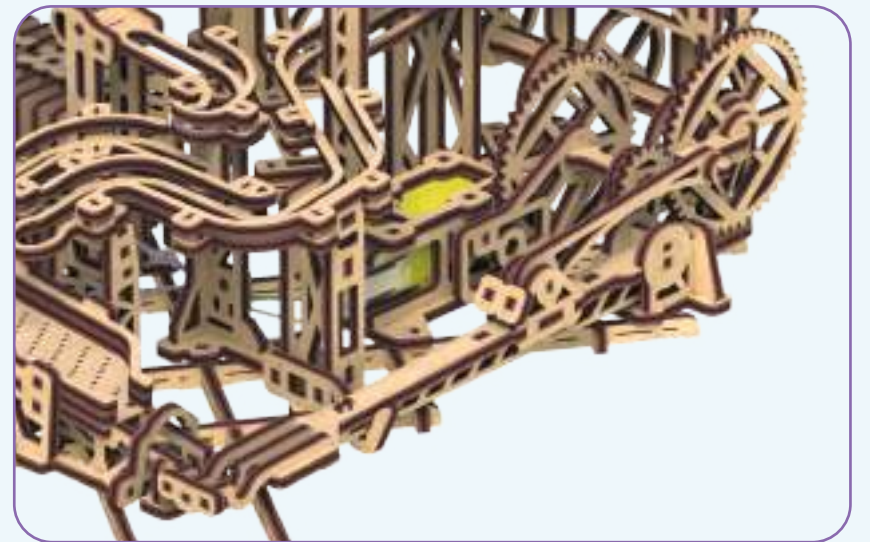
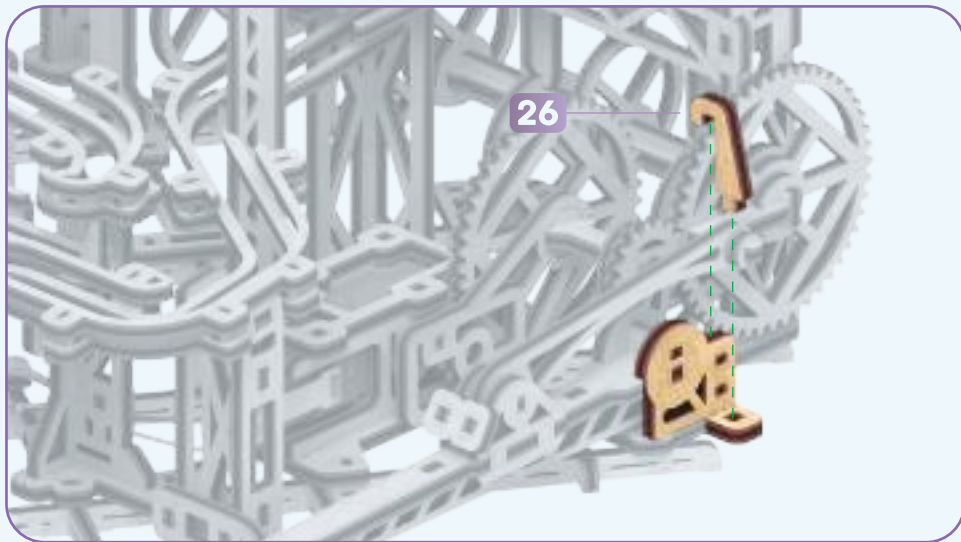
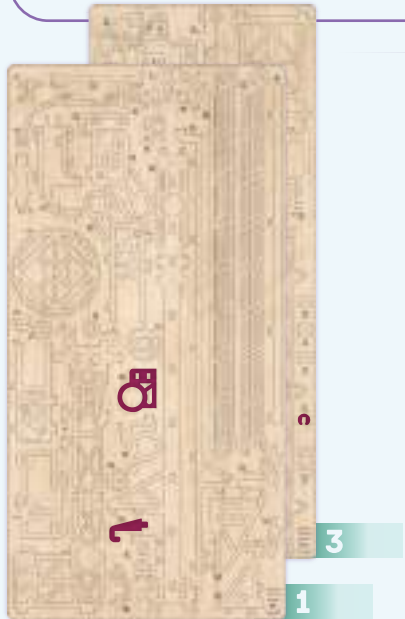
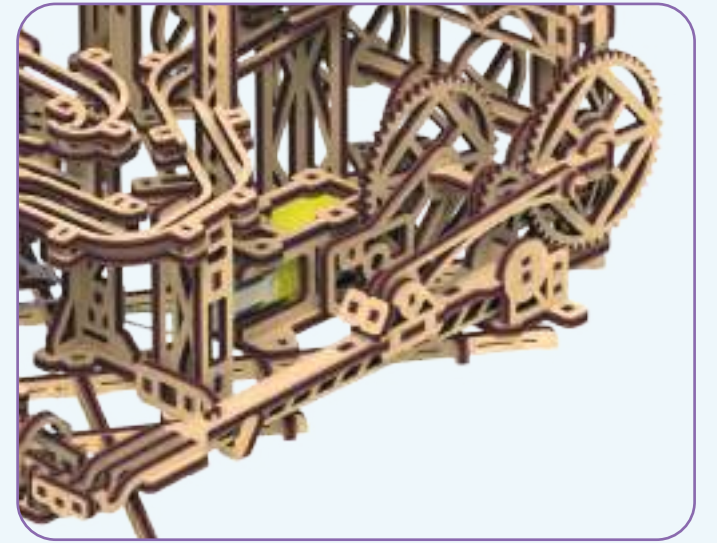
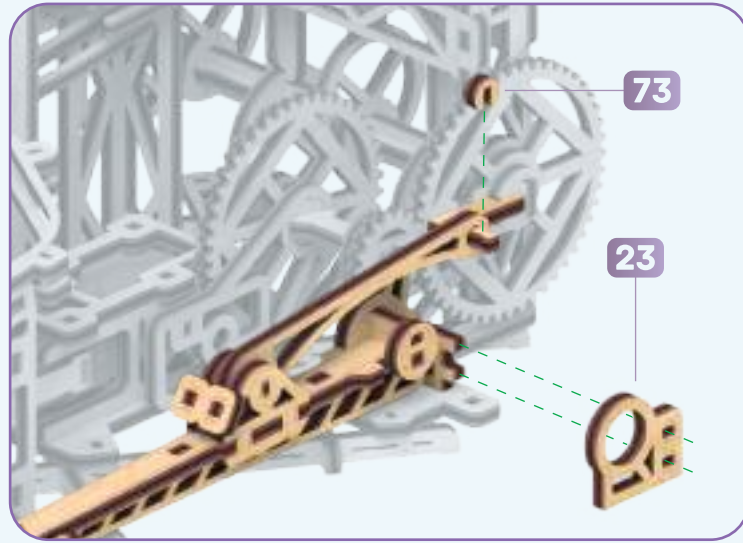
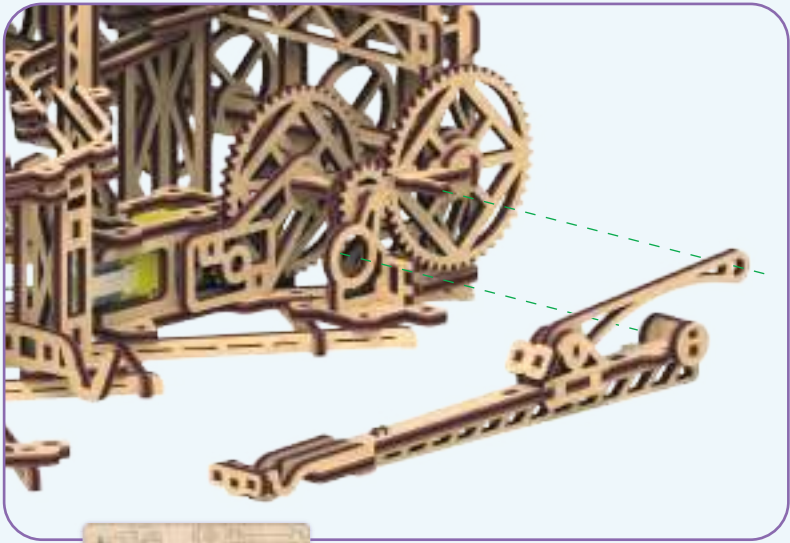

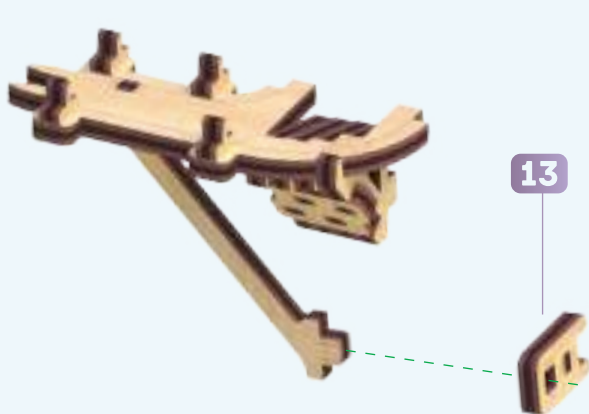
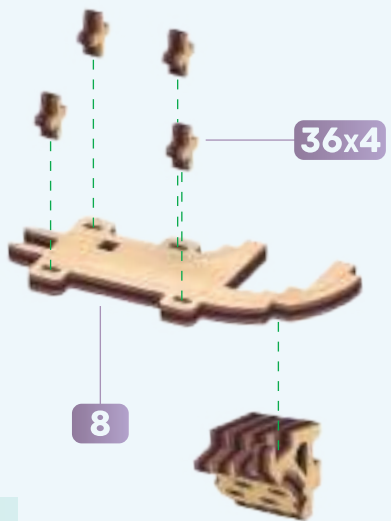
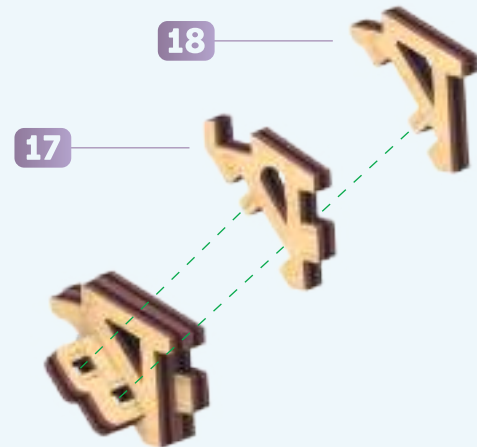
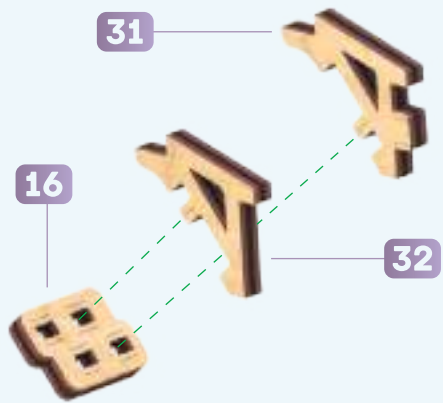
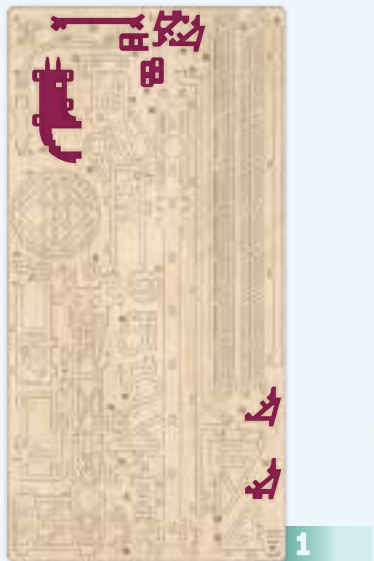

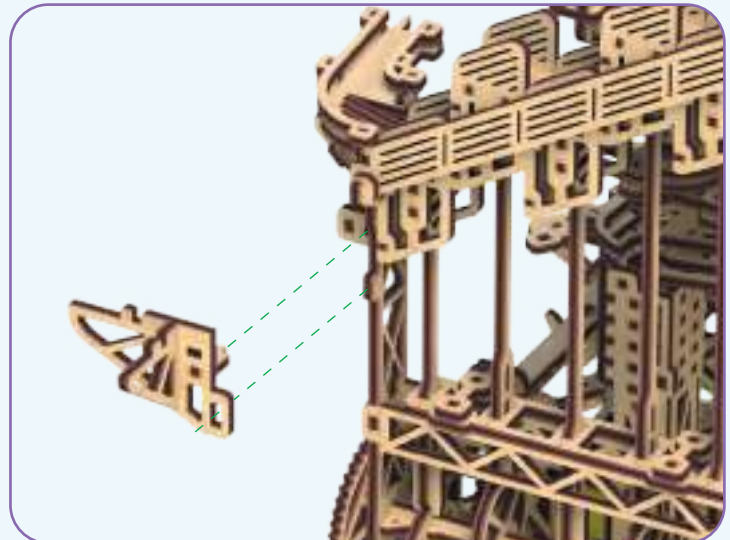
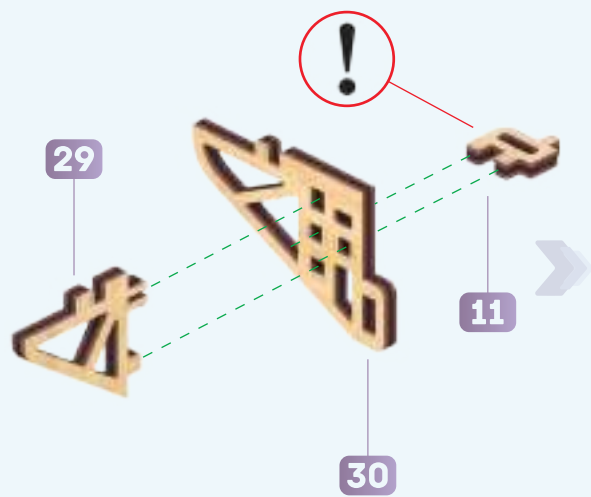
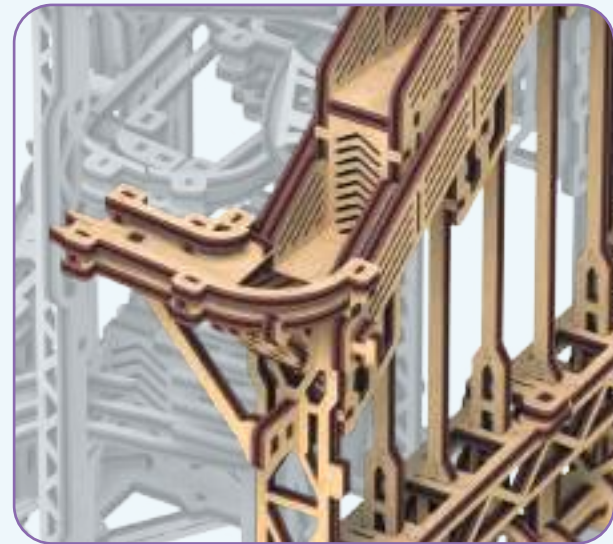
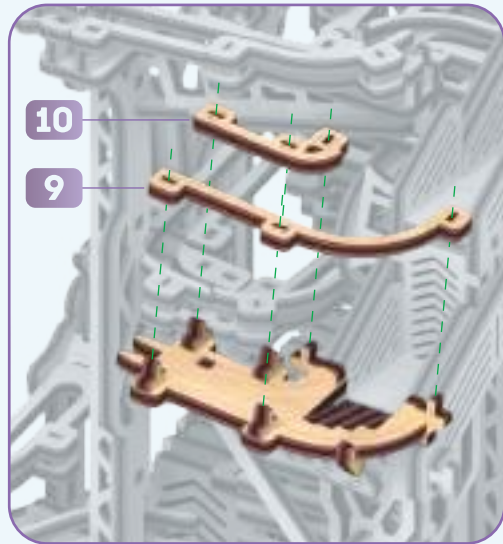
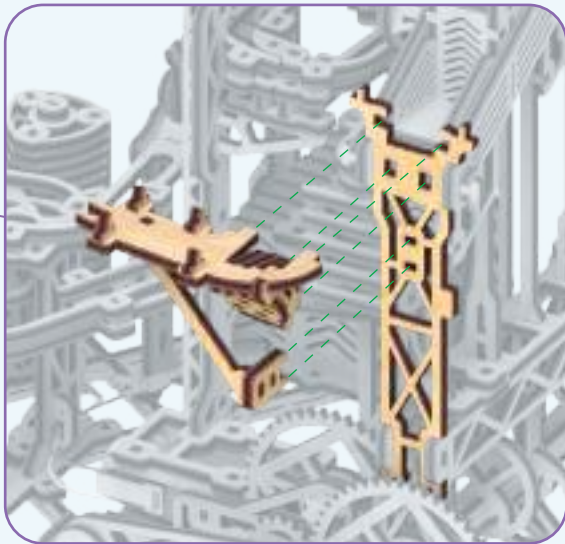
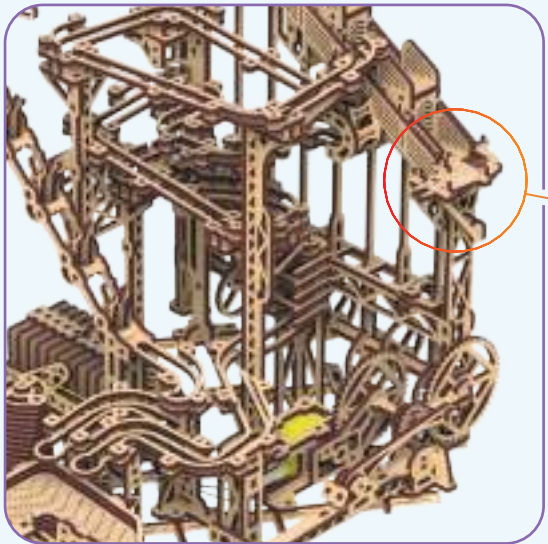

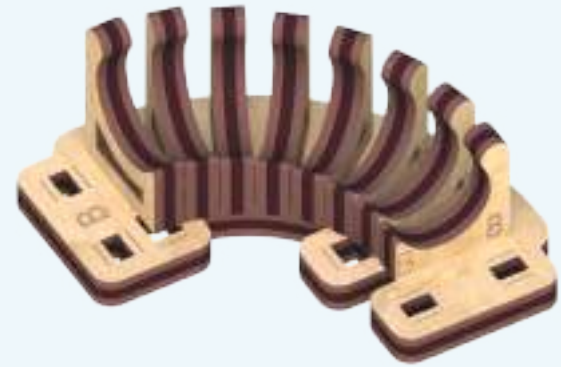
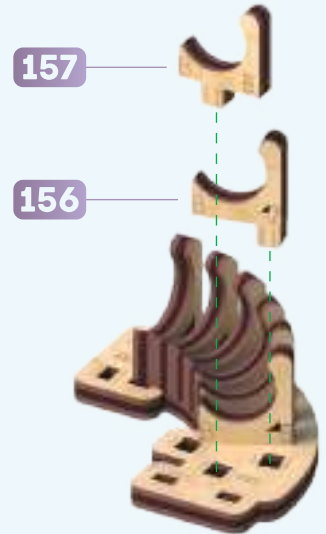
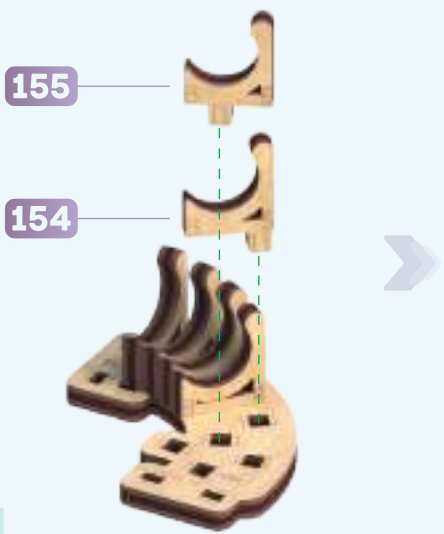
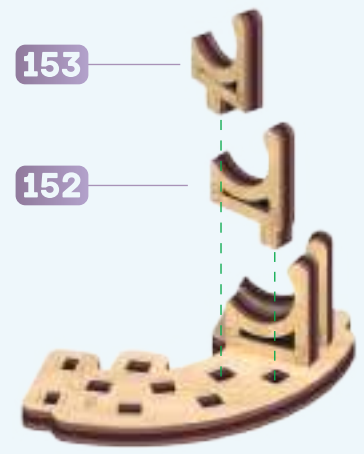
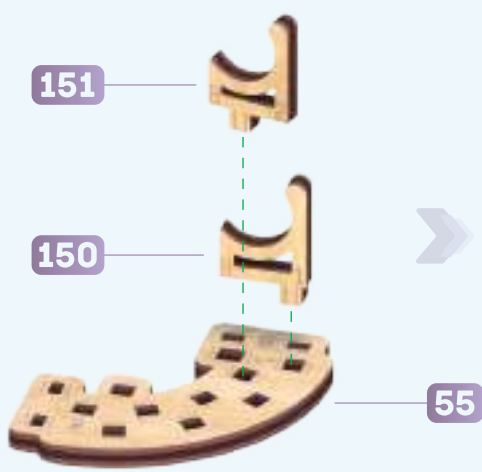
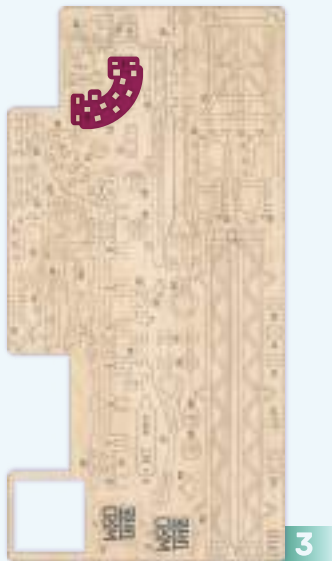

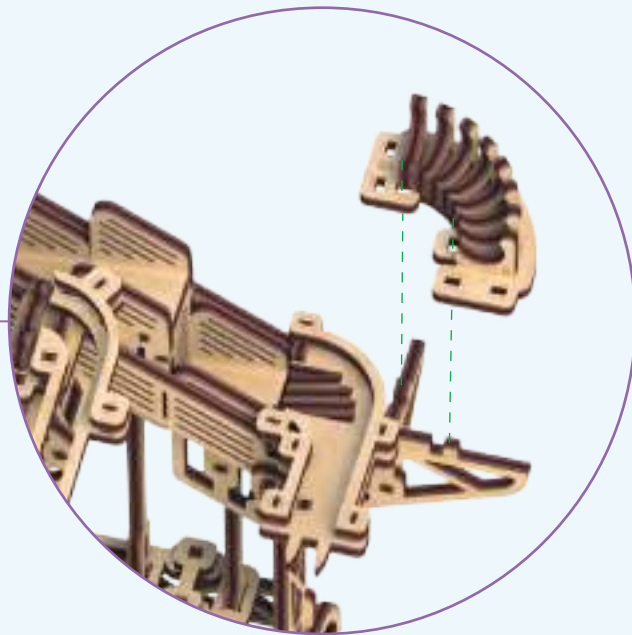
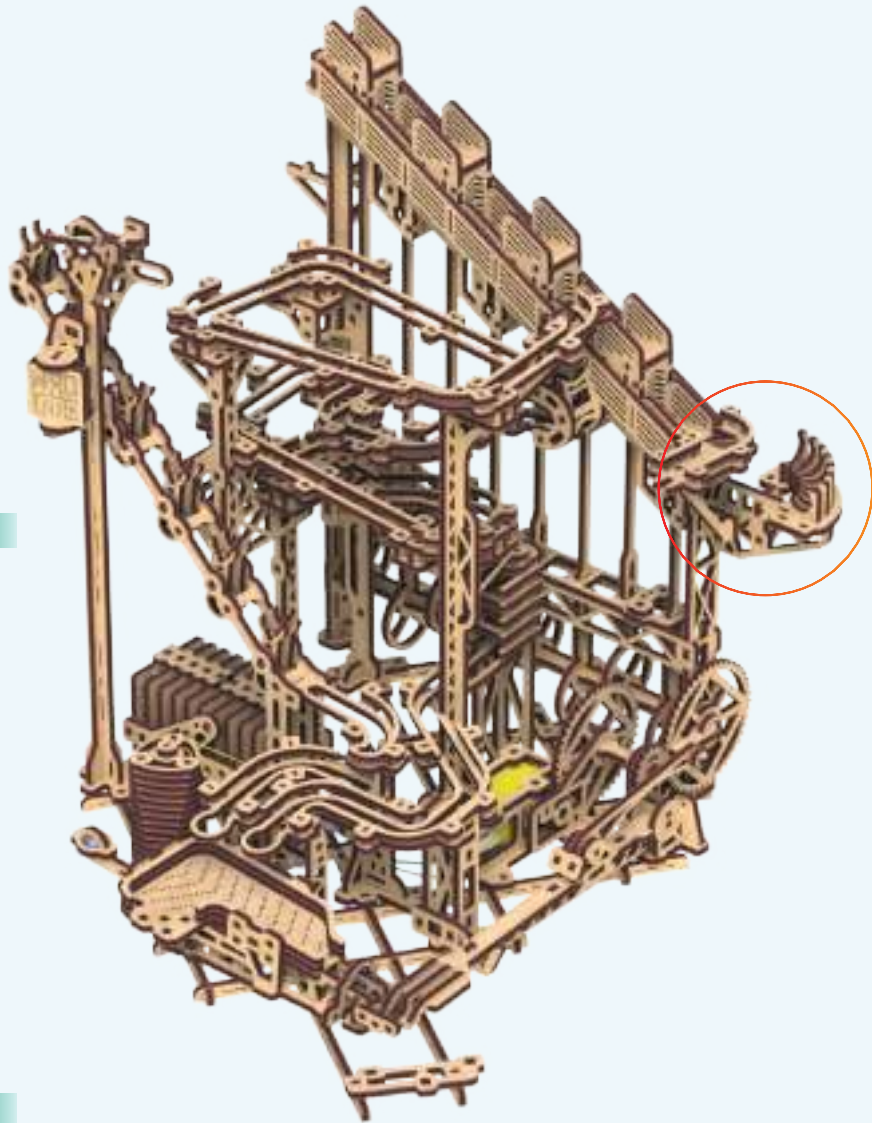
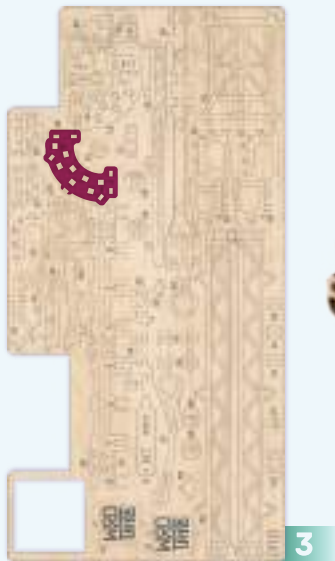



3

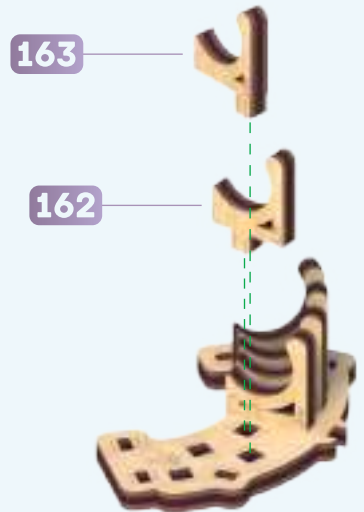
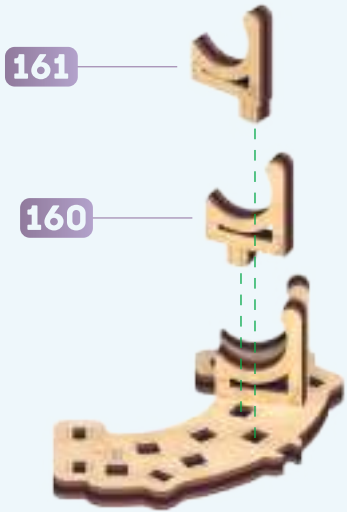

6

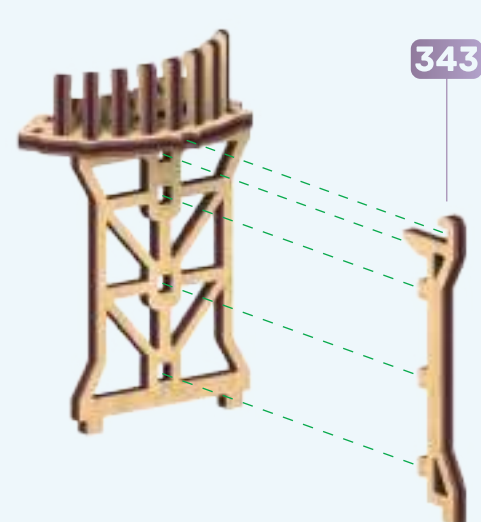
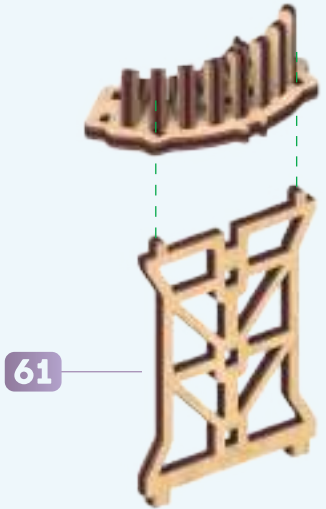
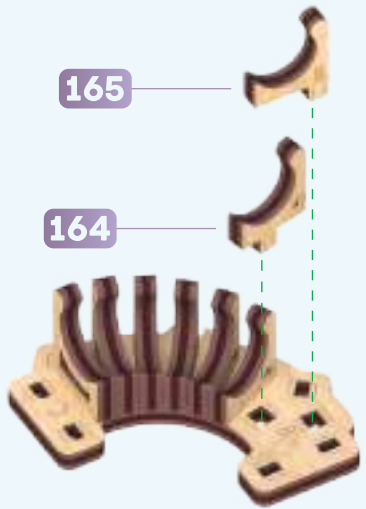

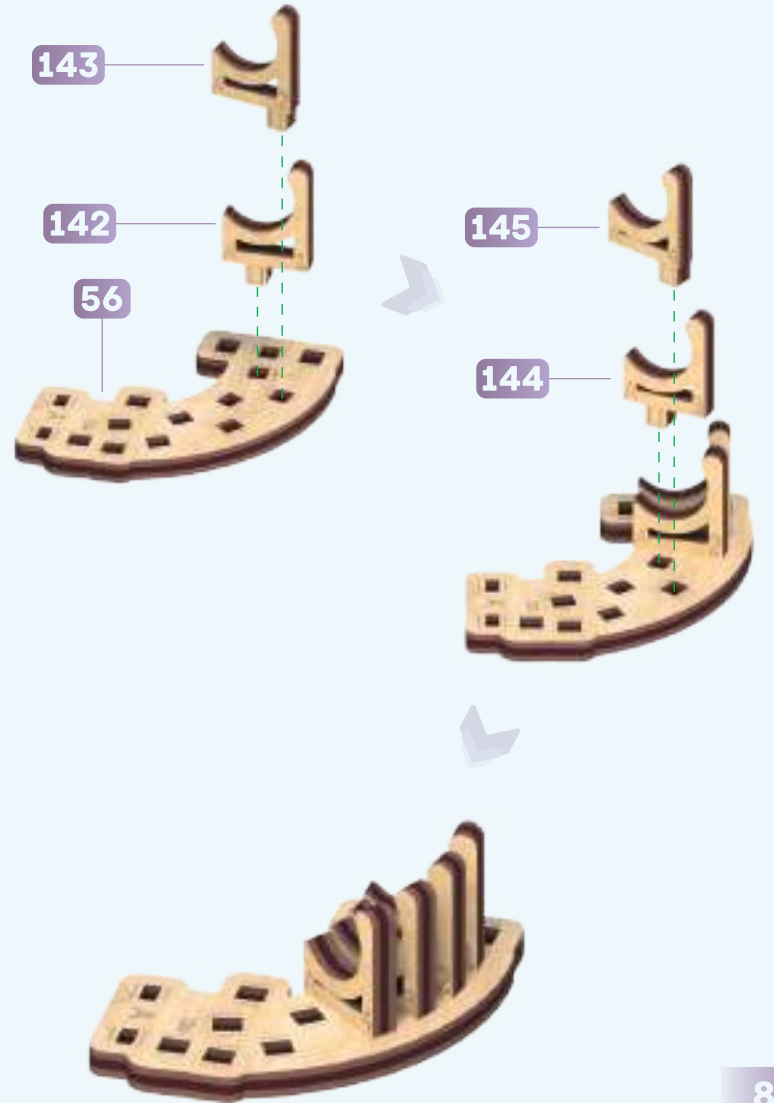
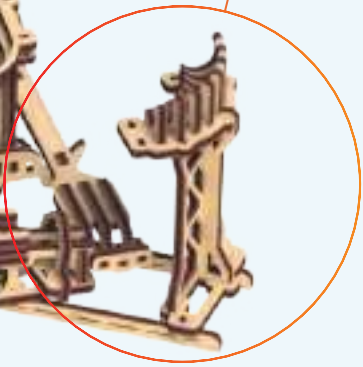
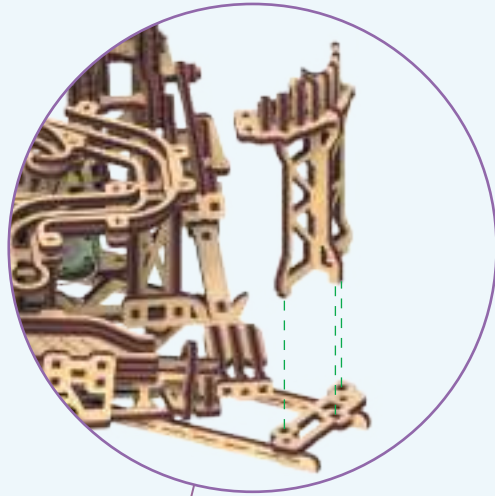
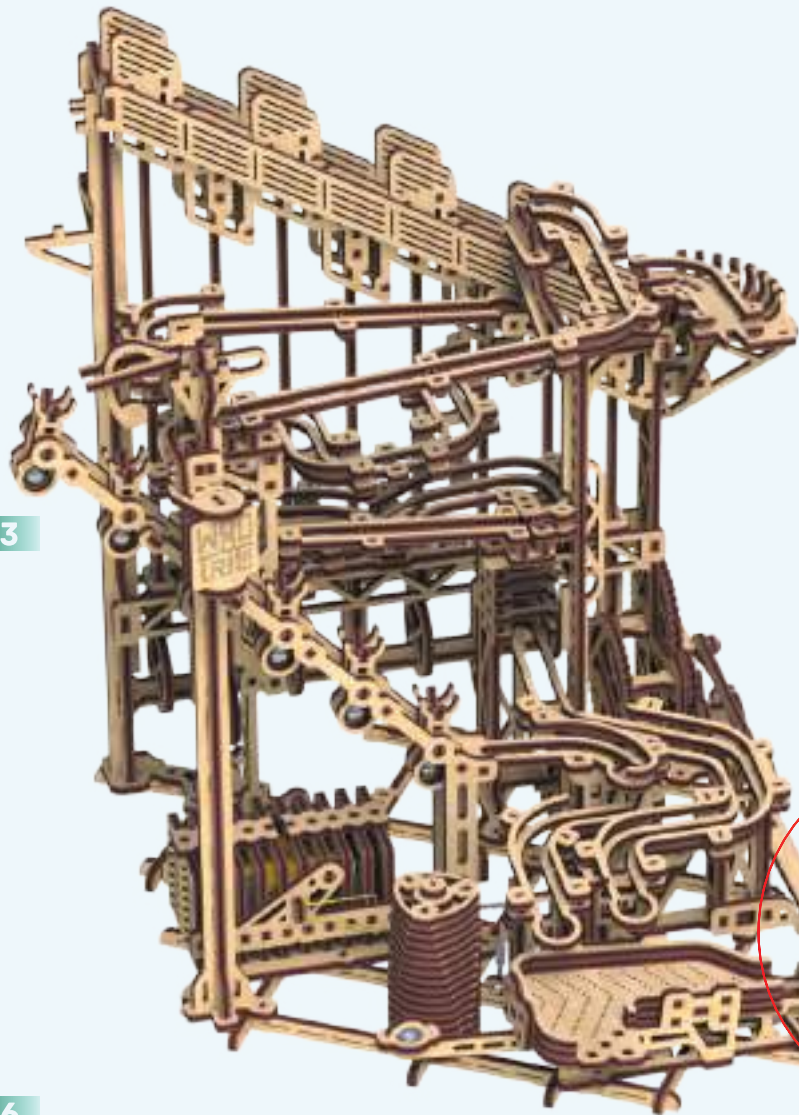

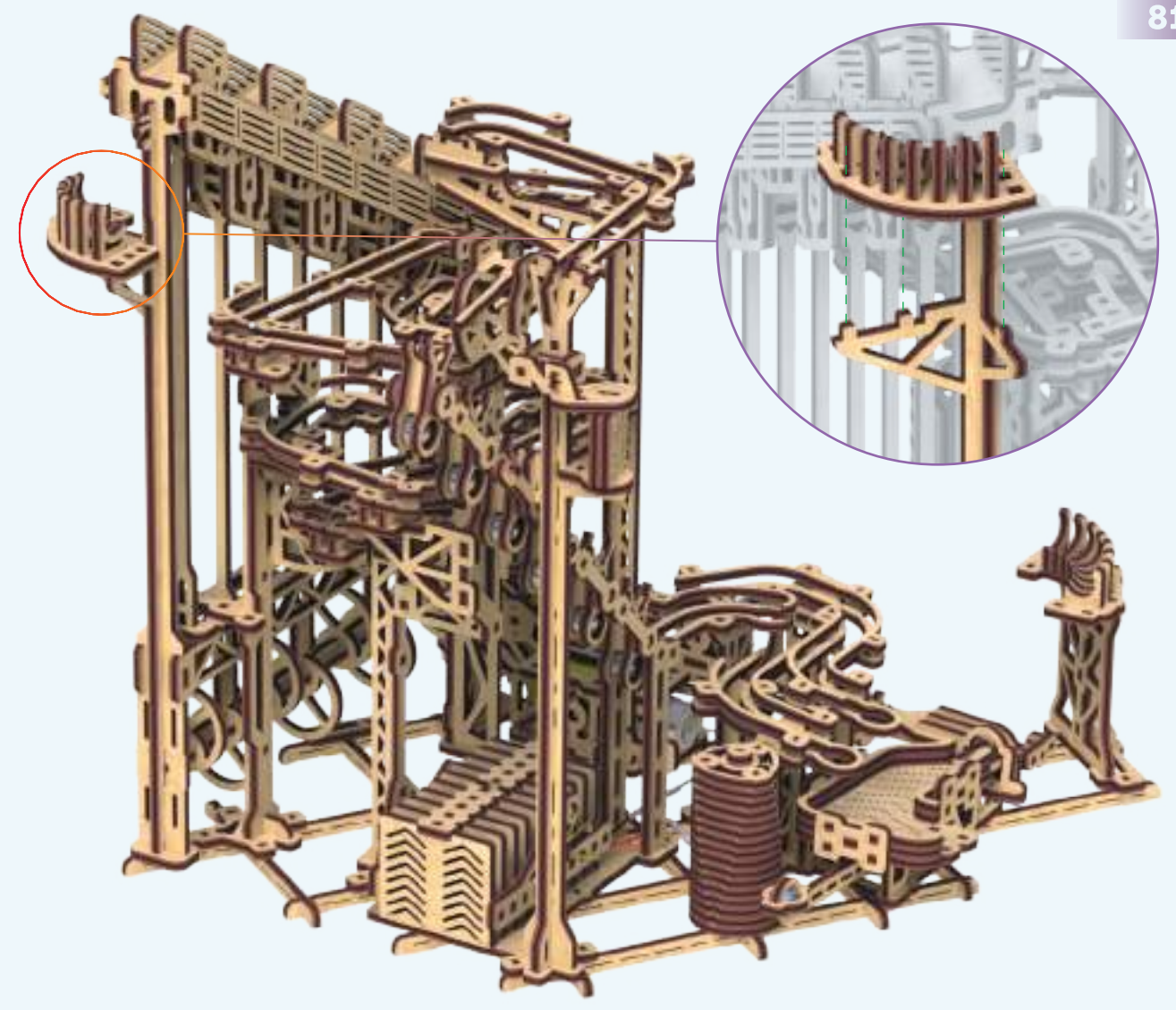
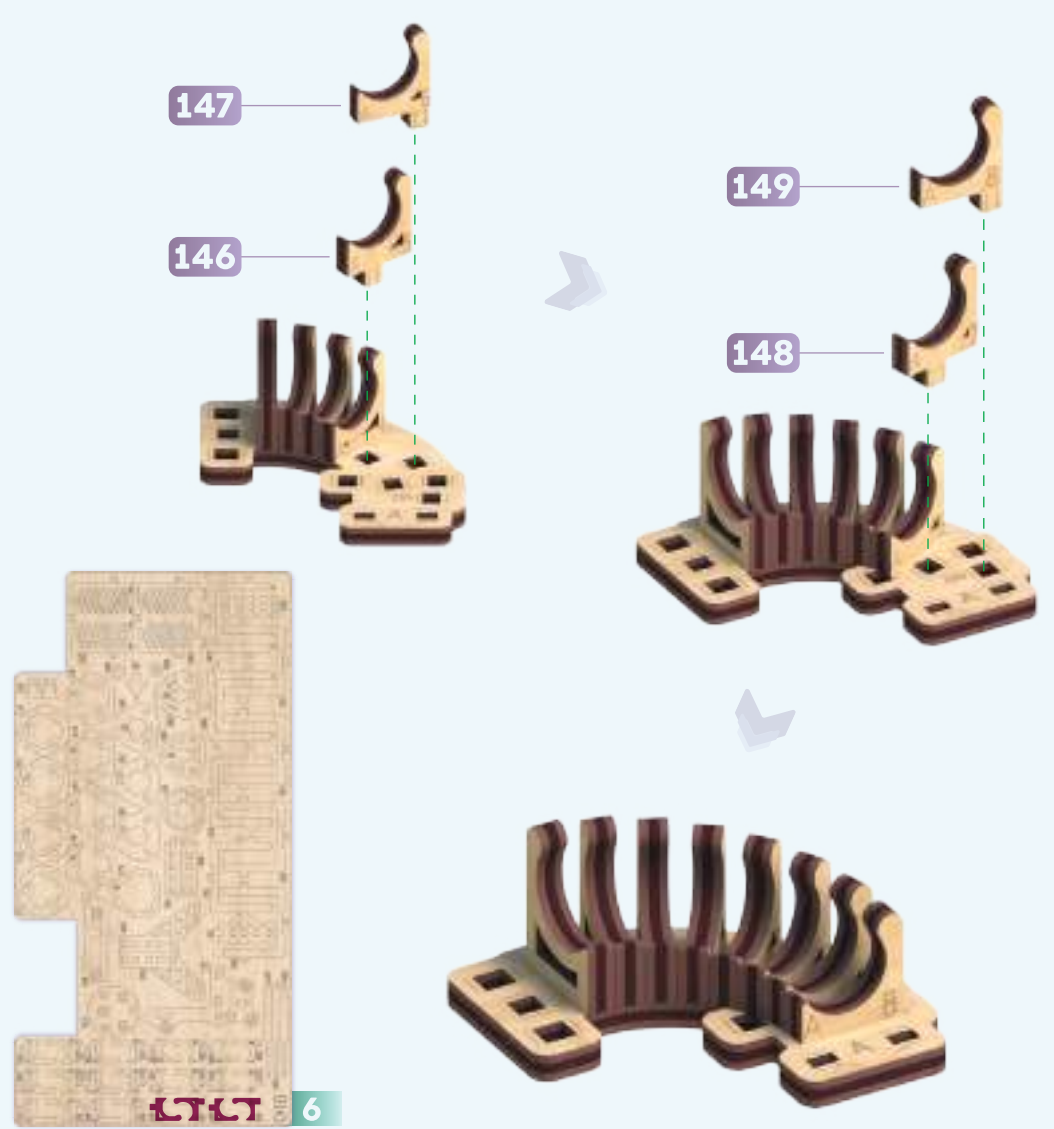

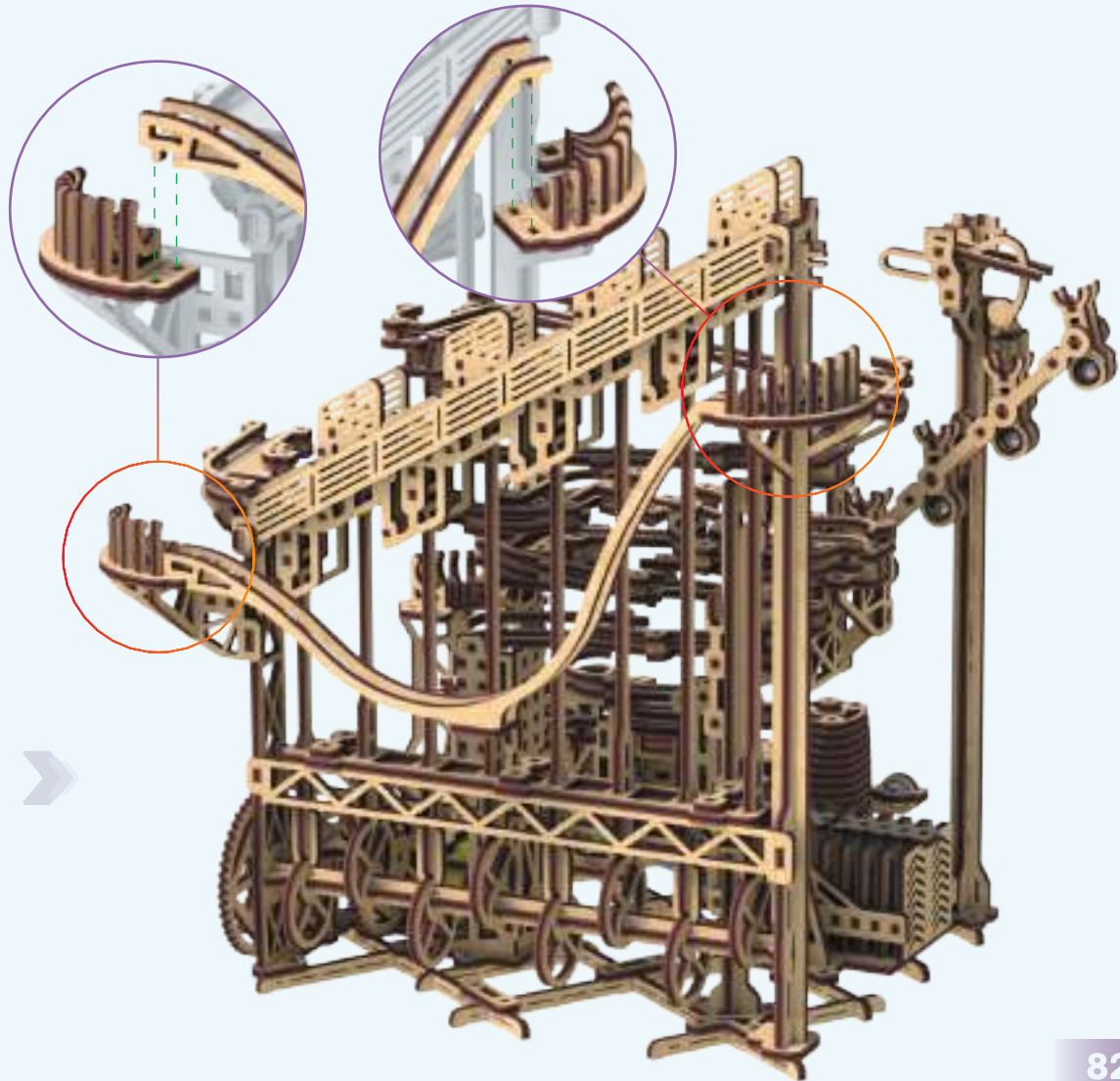
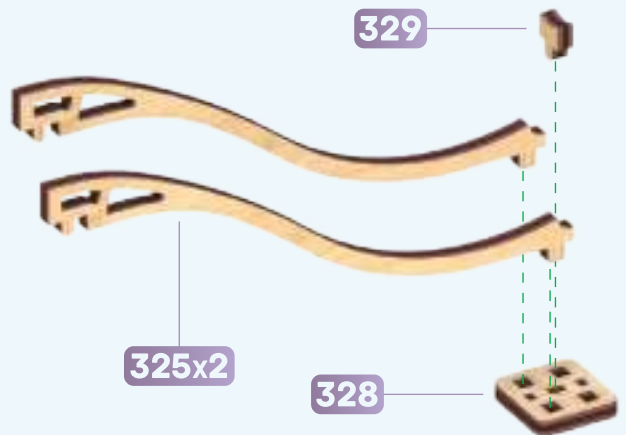

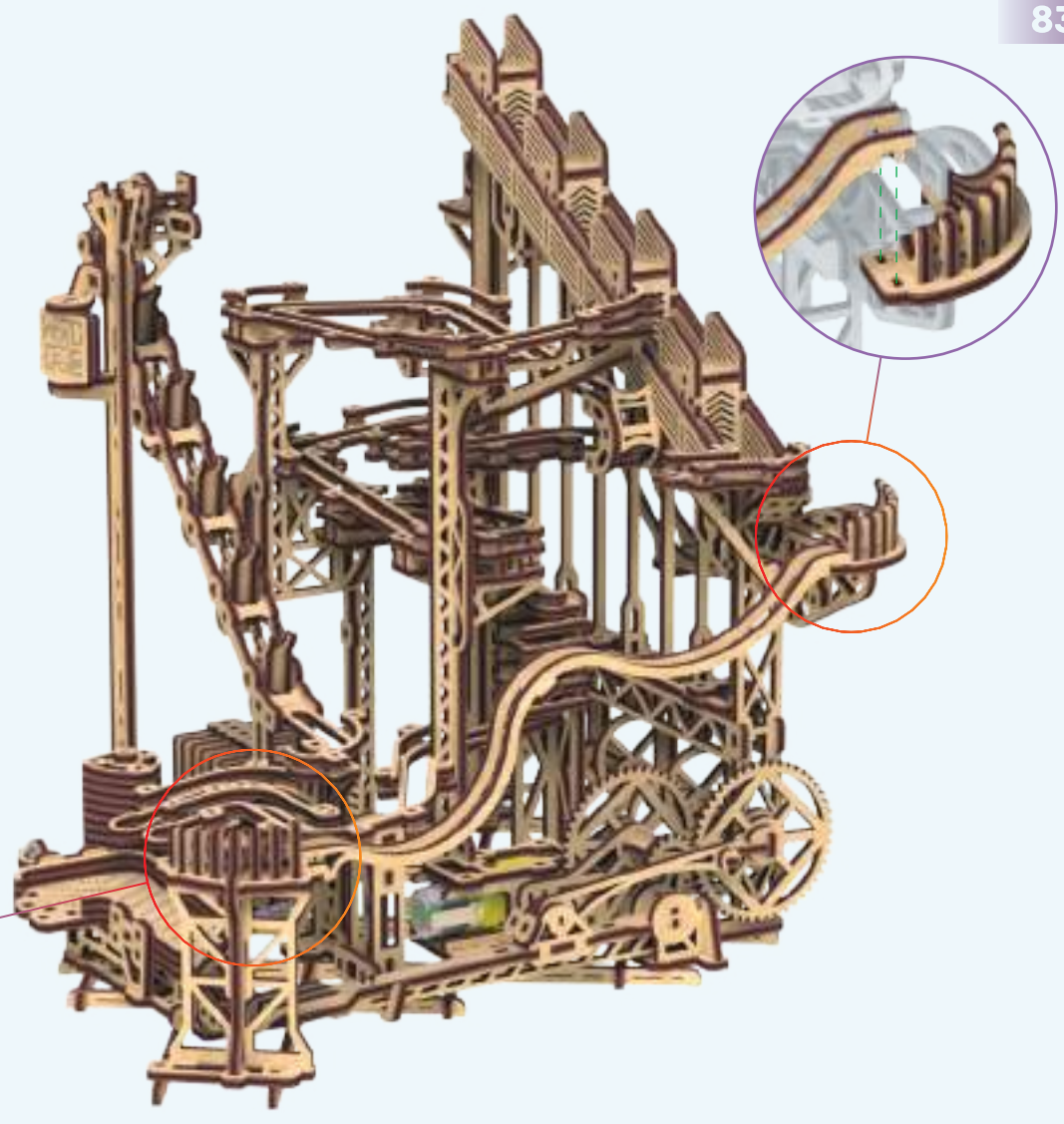
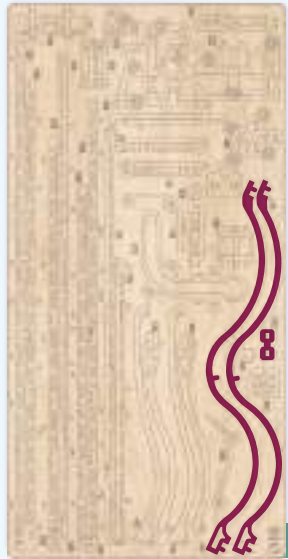

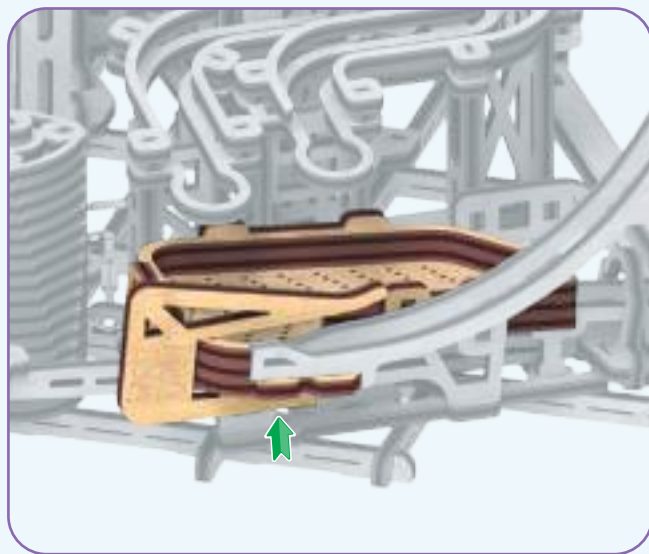
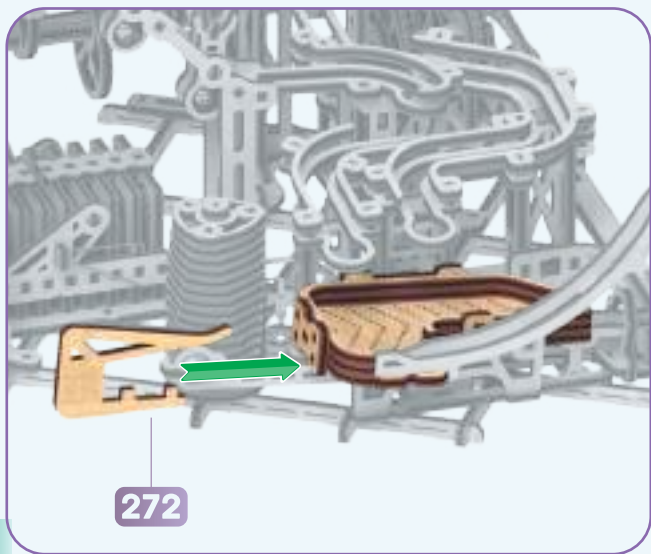
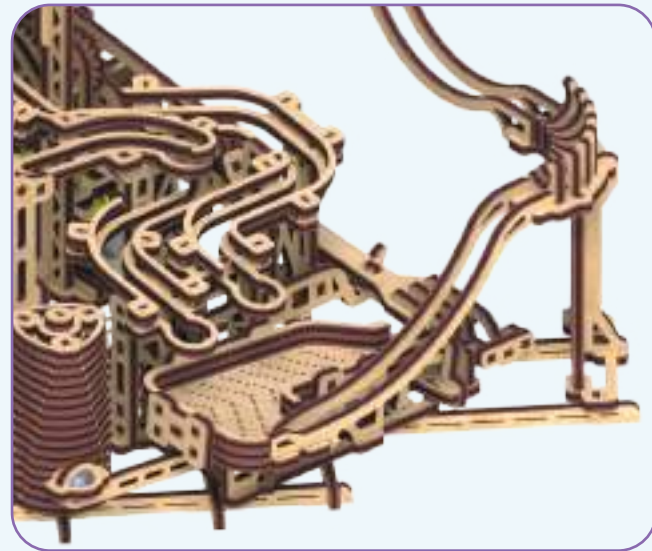
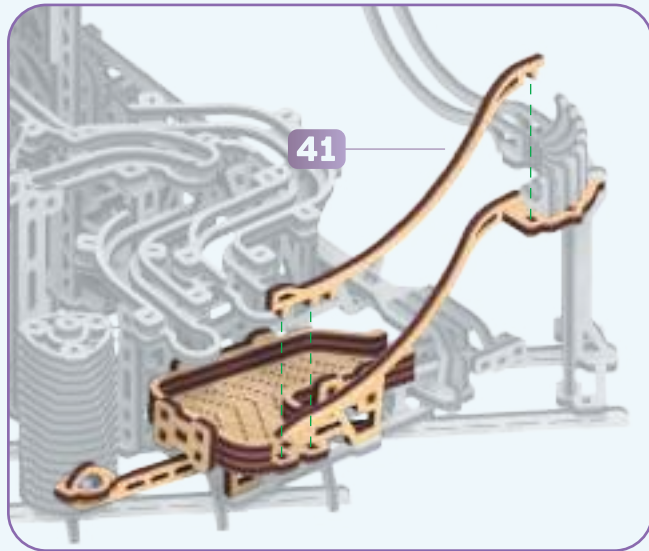
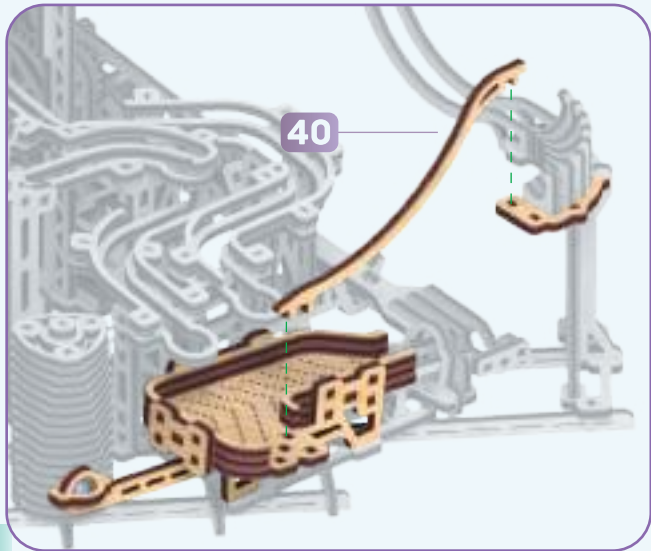



2

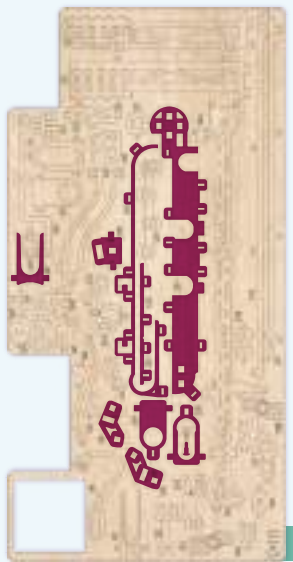
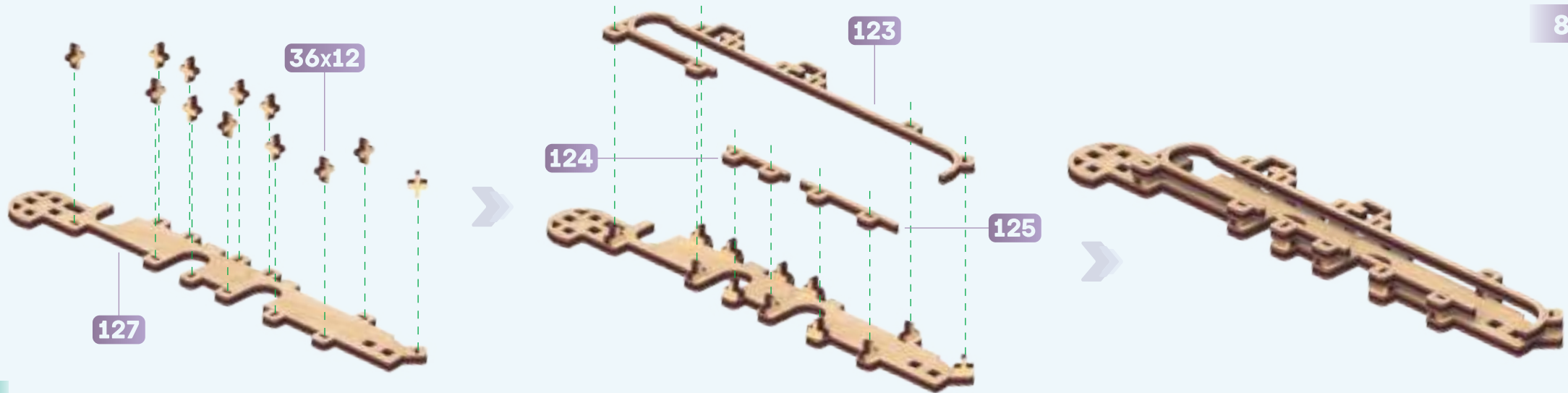

5

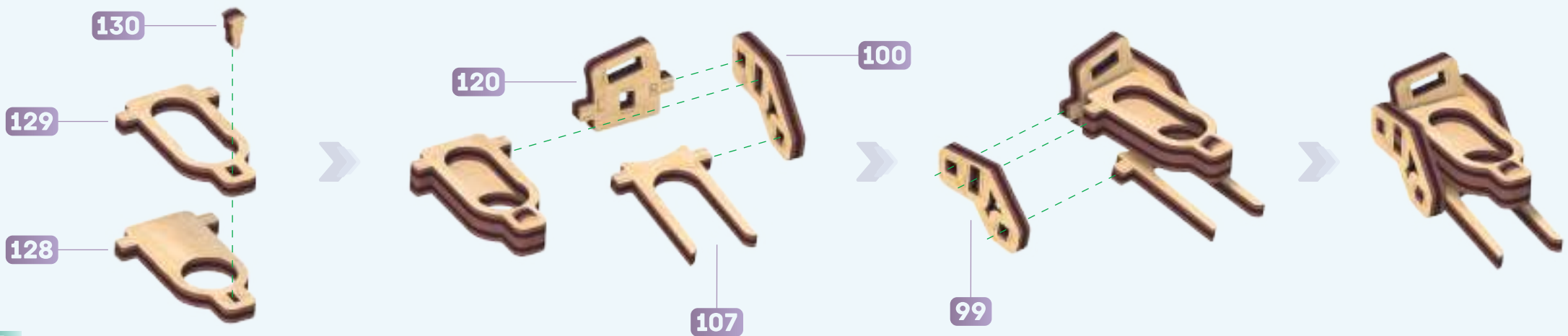

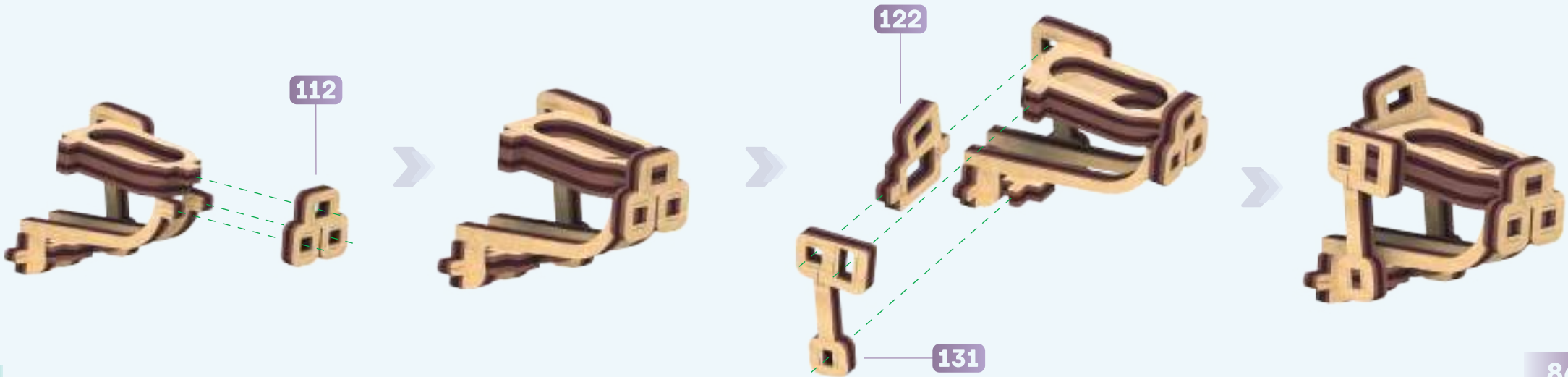
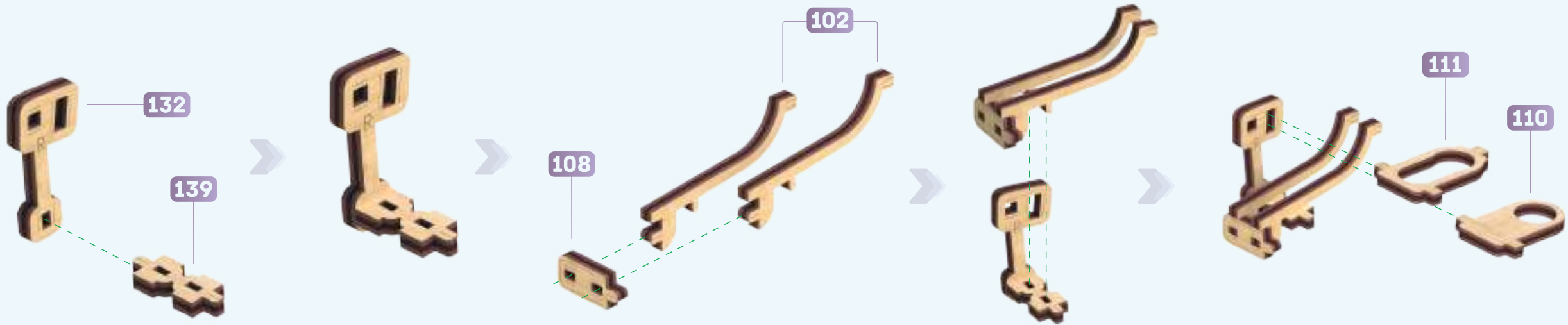



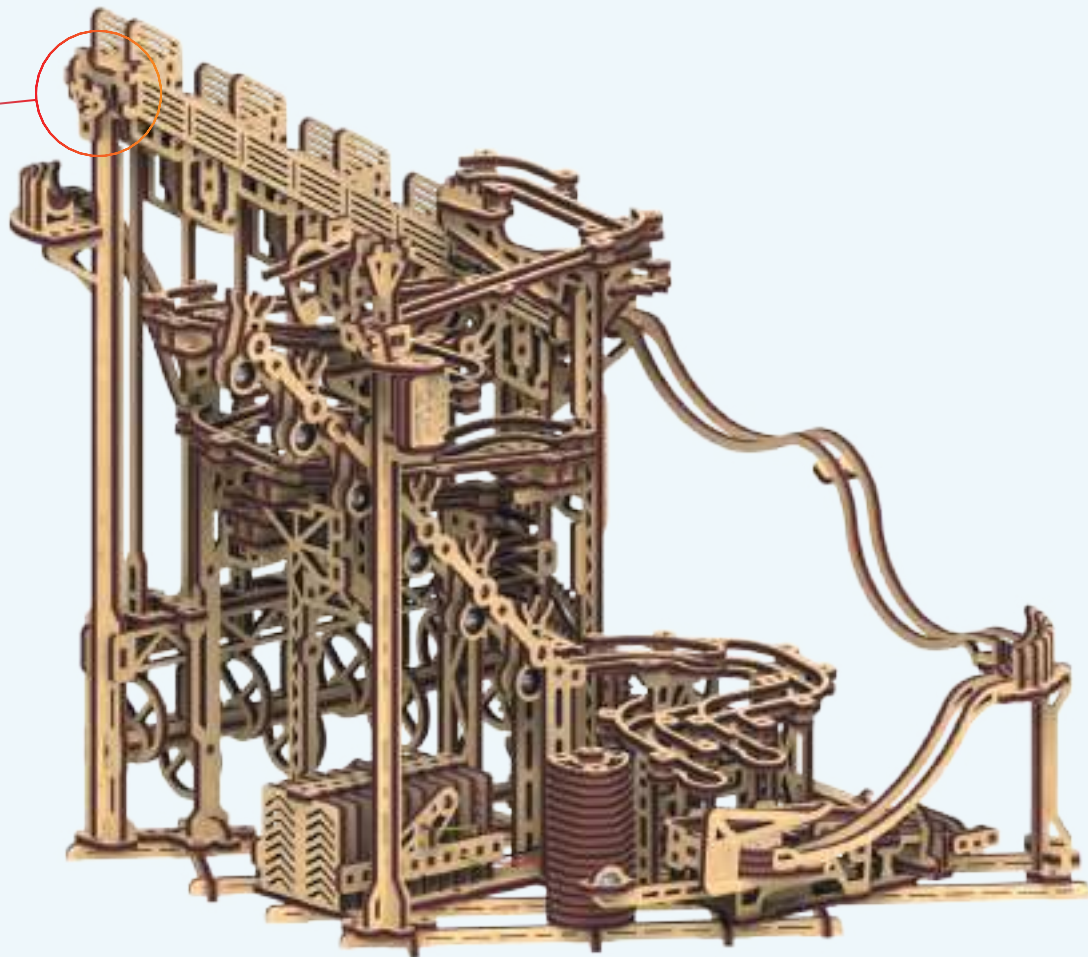
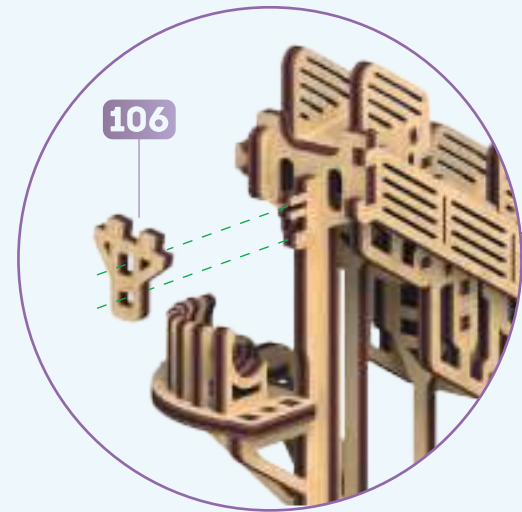

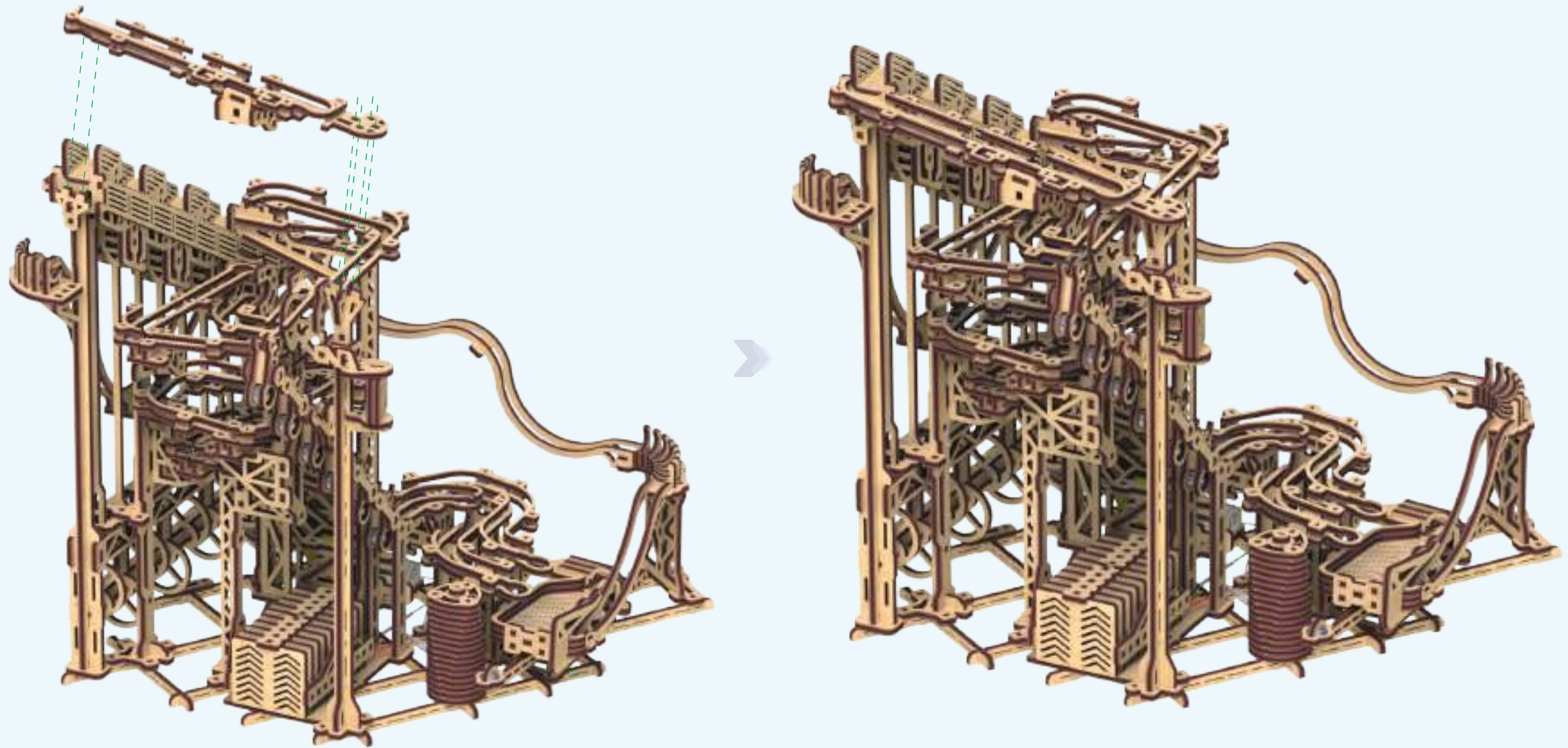

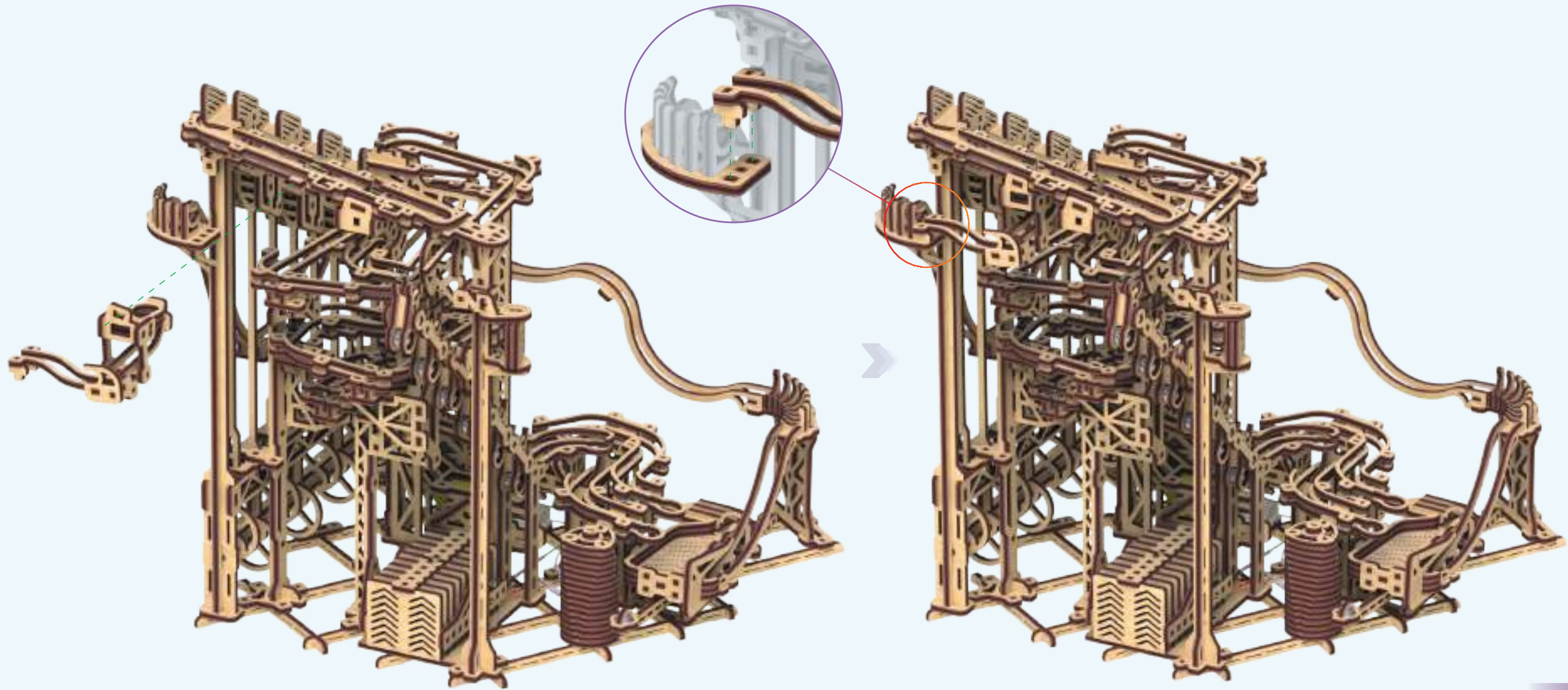

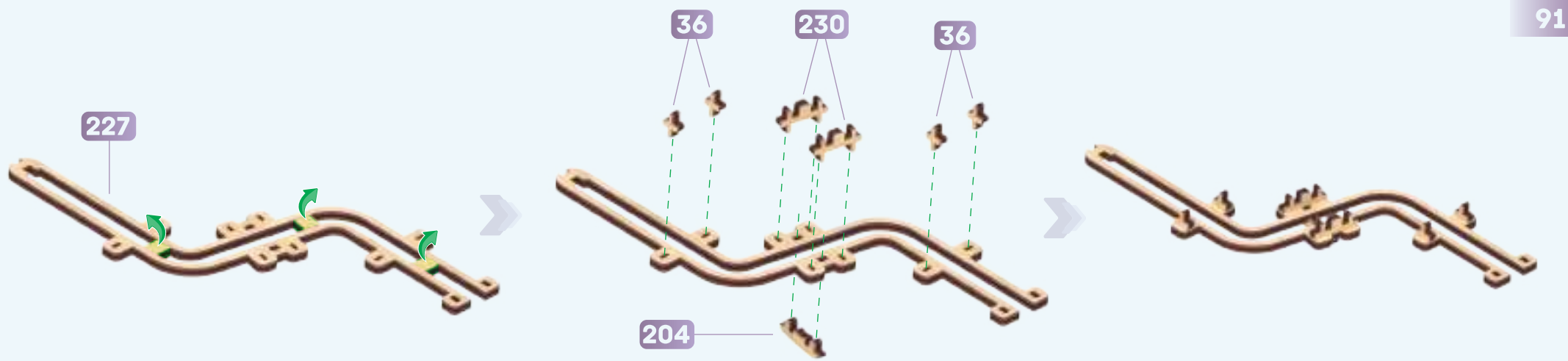
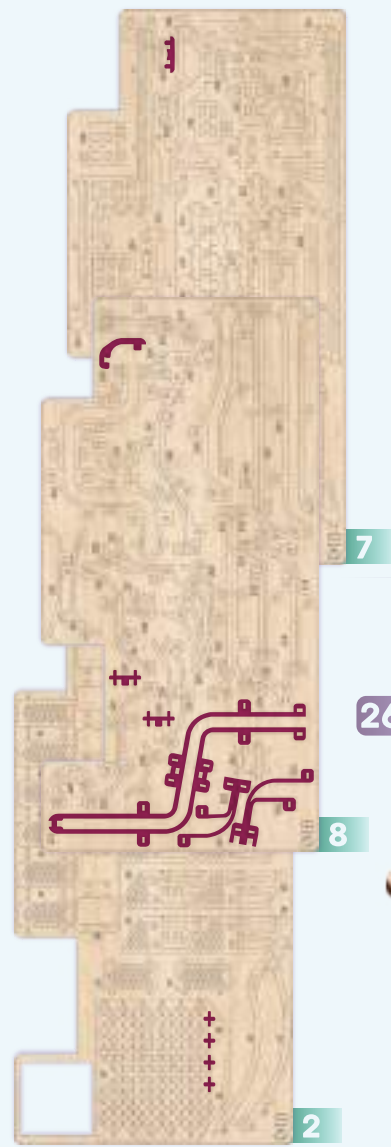

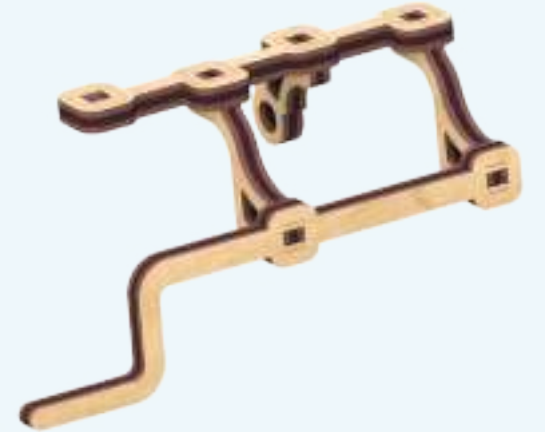
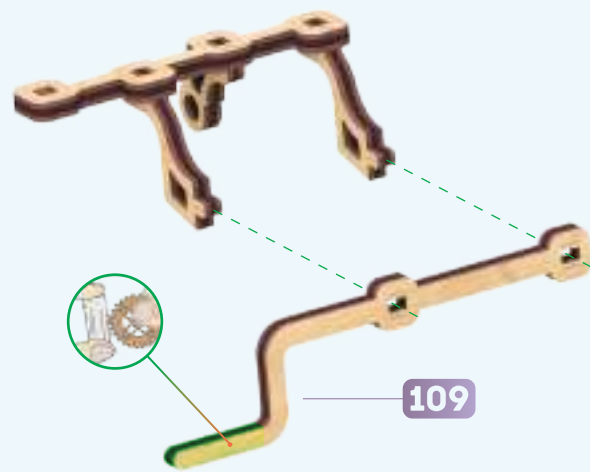
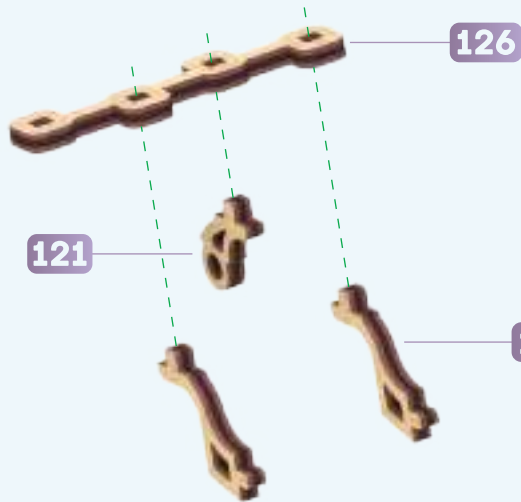
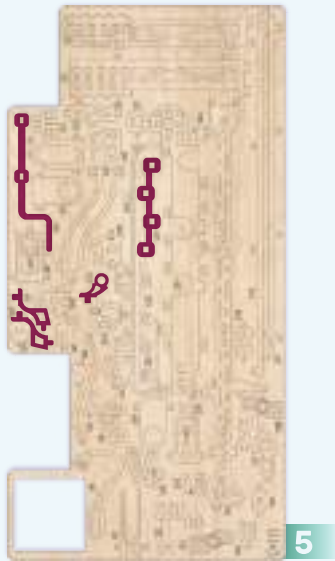
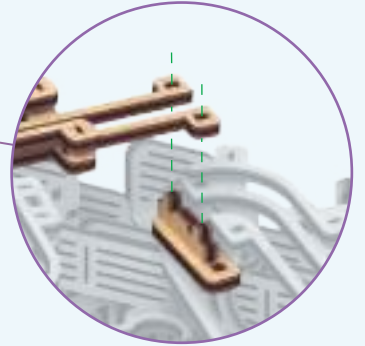
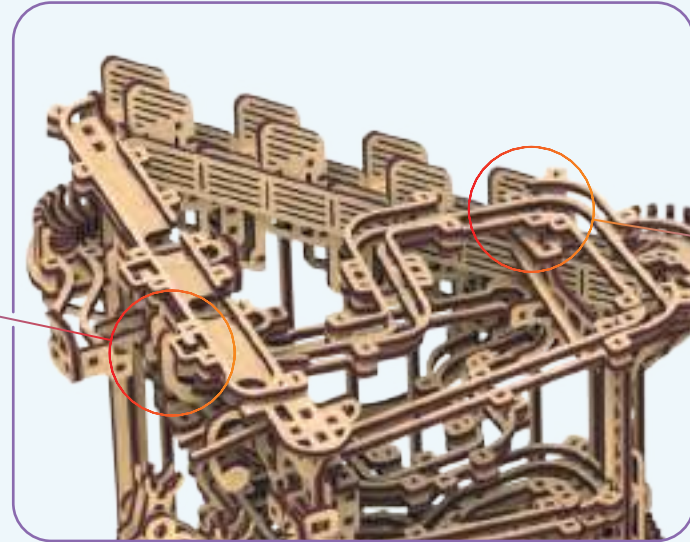
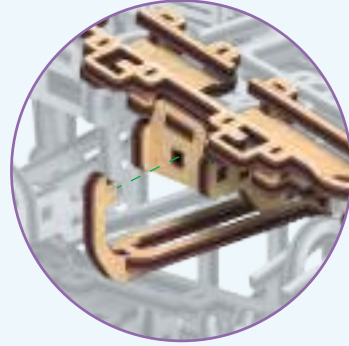
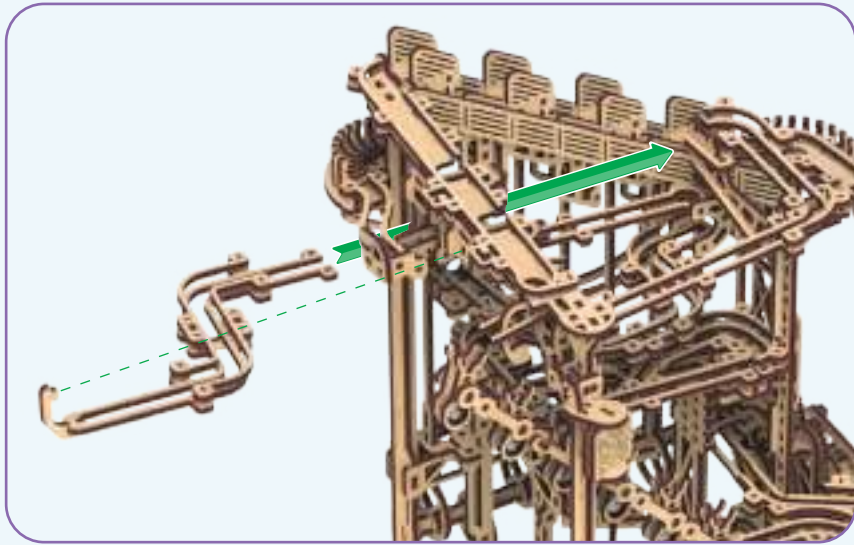

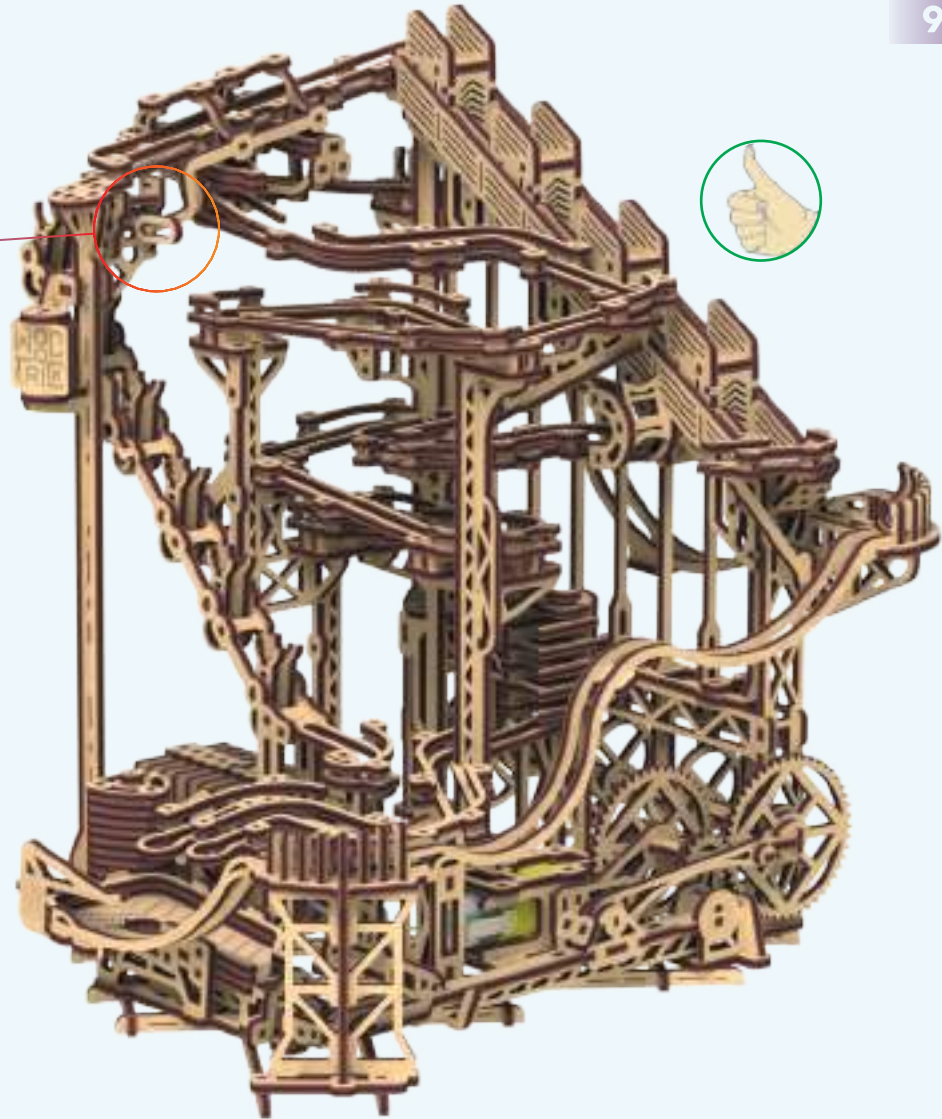
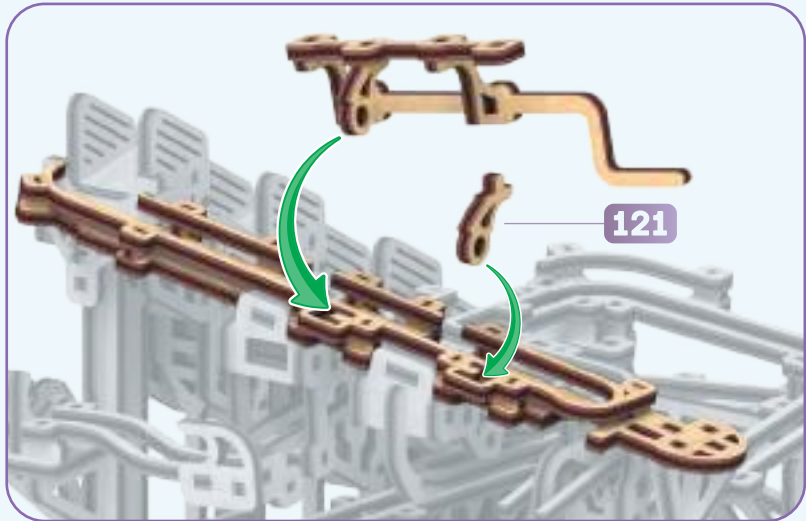

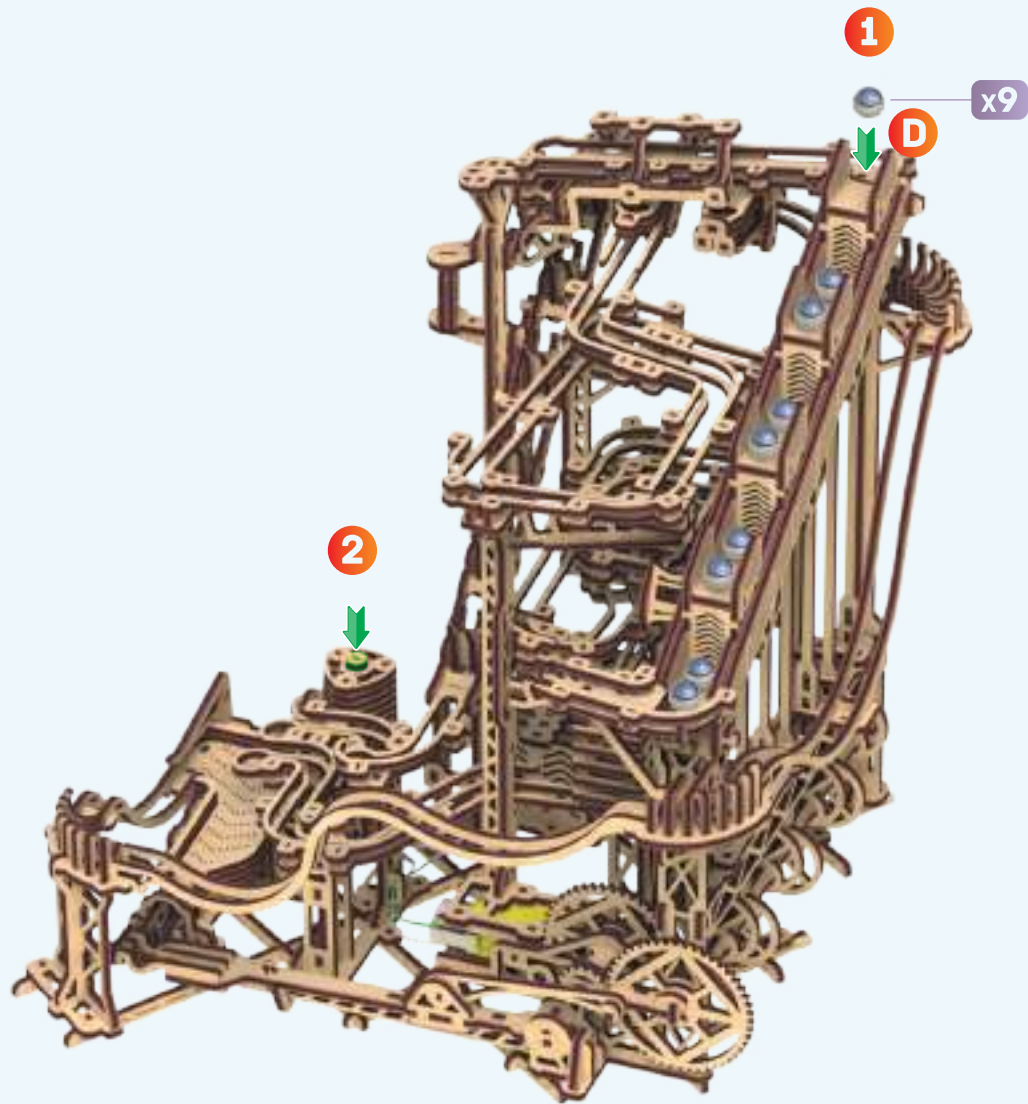

EN Replacing the batteries.

UA Заміна батарейок.

DE Batteriewechsel.

FR Remplacement des piles.

ITL Sostituzione delle batterie.

ES Sustitución de las pilas.

PL Wymiana baterii.

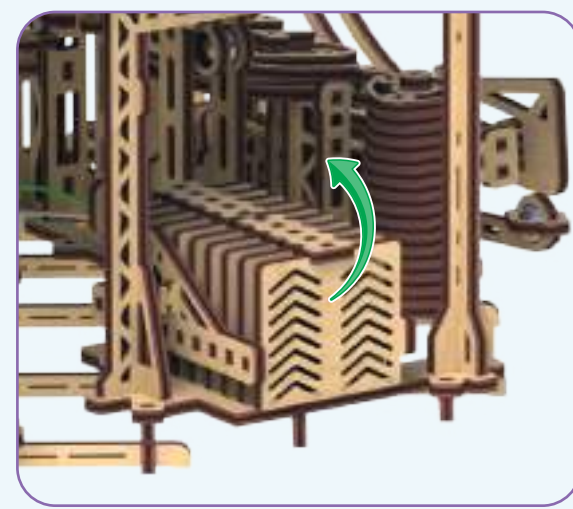



HOW TO REPLACE A BROKEN PART

Sometimes it happens that a part of the WoodTrick model is lost or damaged.

But you have nothing to worry about because we have the replacement service. This option is free and quick, and you can easily use it for missed or damaged parts of your WoodTrick constructor.

MAKE THE REPLACEMENT IN 5 SIMPLE STEPS

STEP 1

Open the Replacement form on our website woodtrick.com.

Or you can scan the QR code, which will redirect you to the replacement page.



STEP 2

Indicate the reason for replacement.

There is no need to attach the photo or video of the broken part, it's enough to choose the reason in the list.

STEP 3

Mention the name or the set number of the WoodTrick model with the missing part.

Name: SPIRAL MARBLE RUN
Set number: WDTK056

STEP 4

Choose the board* which contains the part you need.

*All parts and all boards have the numbers. For the replacement you'll need to mention the № of the board. To find the correct board, use the assembly instruction.

STEP 5

Fill the delivery address and it's done!

FREE REPLACEMENT

For each WoodTrick model we provide 2 (two) free replacements. We always send the full board to avoid the risks of damaging a small part during the delivery. For example, if you need part 14 which belongs to Board 1, we will send the whole Board 1.

NEED SOME HELP?

In case you faced any difficulties with the replacement please contact us: support@woodtrick.com. Our support team is available 24/7 and will assist with the issue. You can also get the consultation from support for any questions about assembly.