

# WOOD TRICK

## ENGINEERING JOOOOOOOOOOY

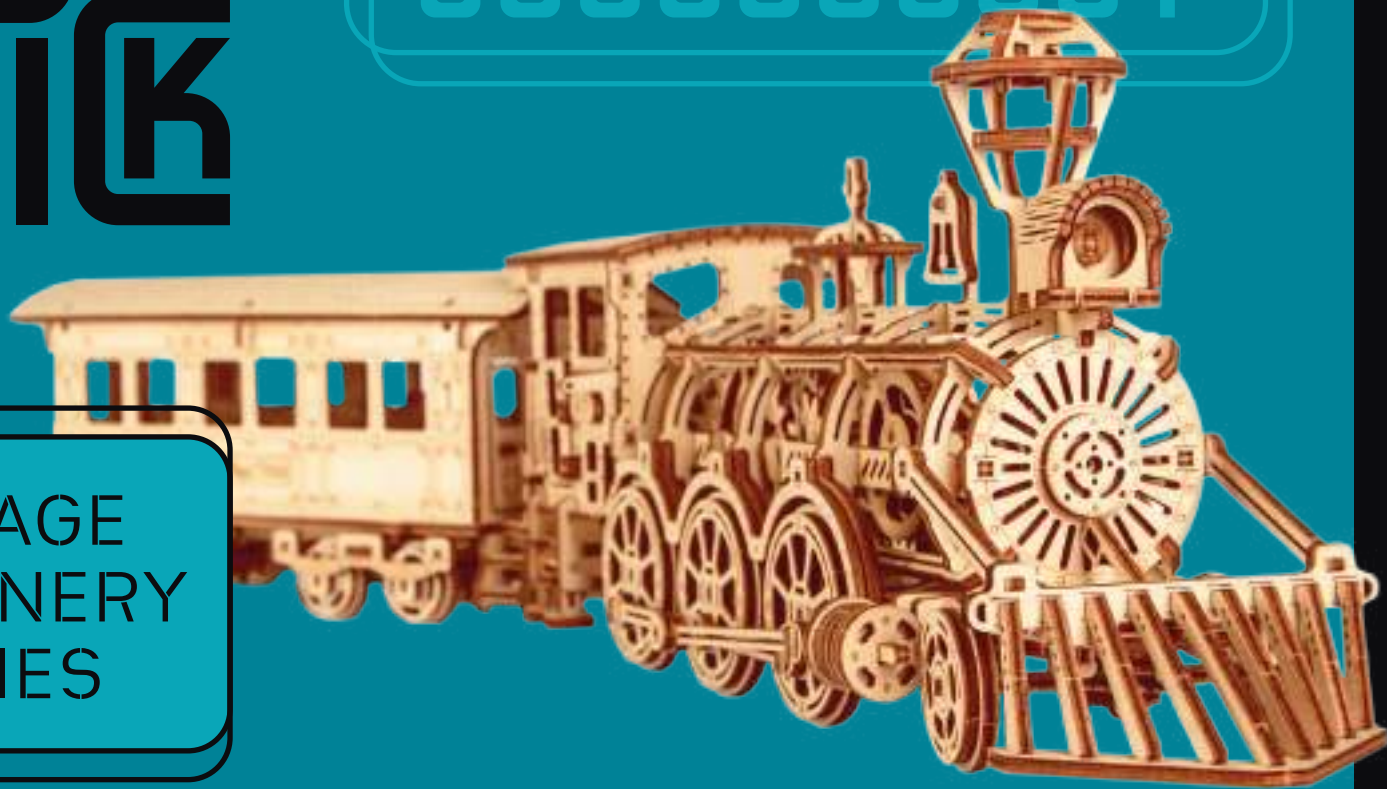

VINTAGE  
MACHINERY  
SERIES

MECHANICAL MODELS & KITS

# LOCOMOTIVE R-17



5 LEVEL

**405**  
PIECES

WDTK022

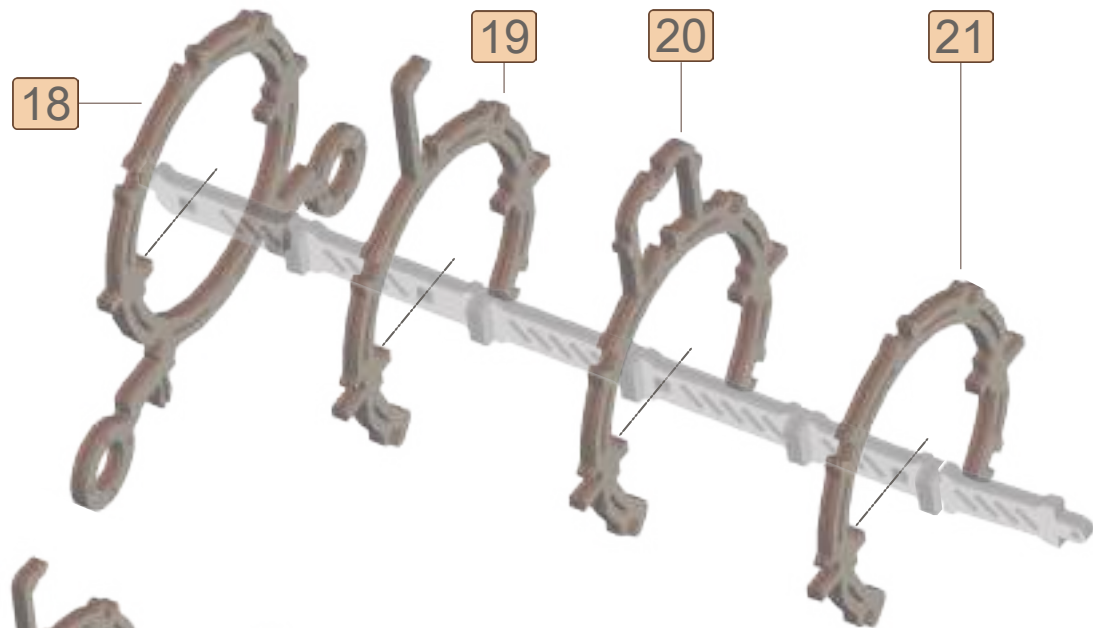
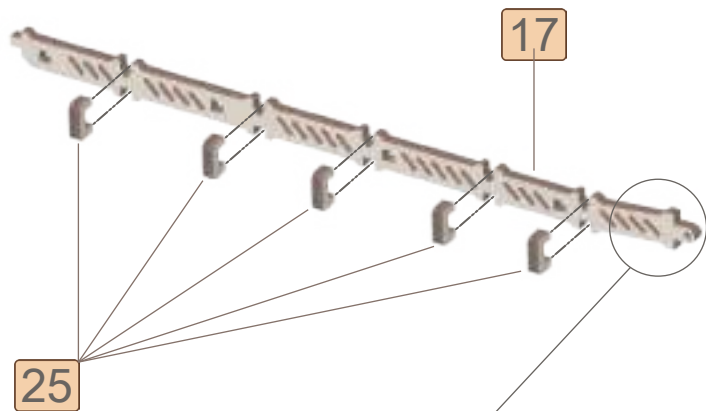
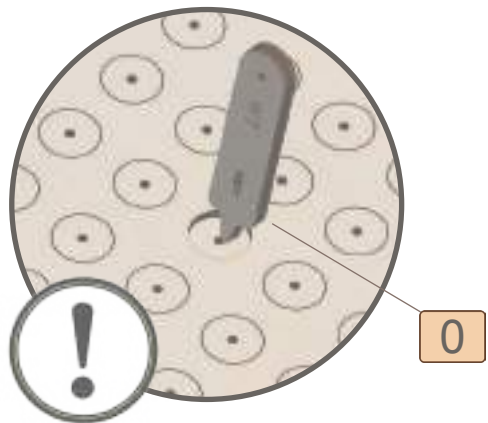

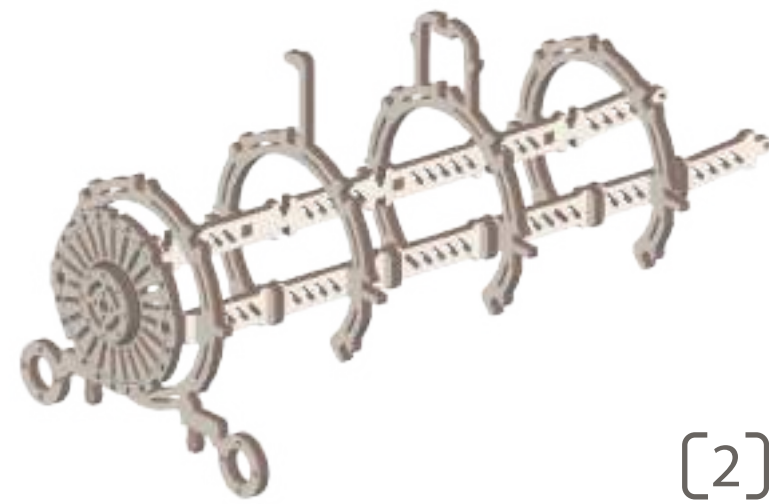
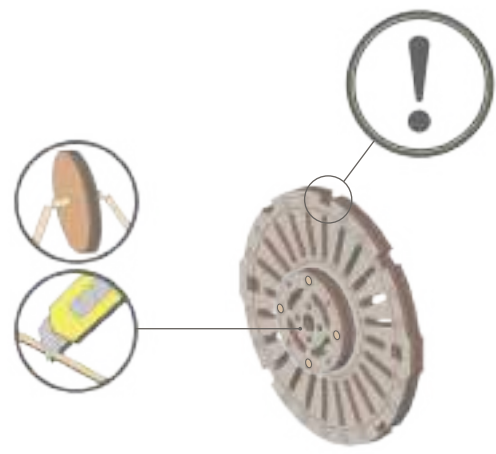
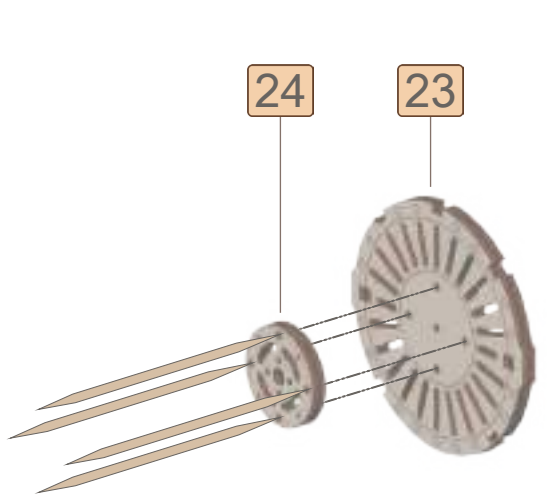
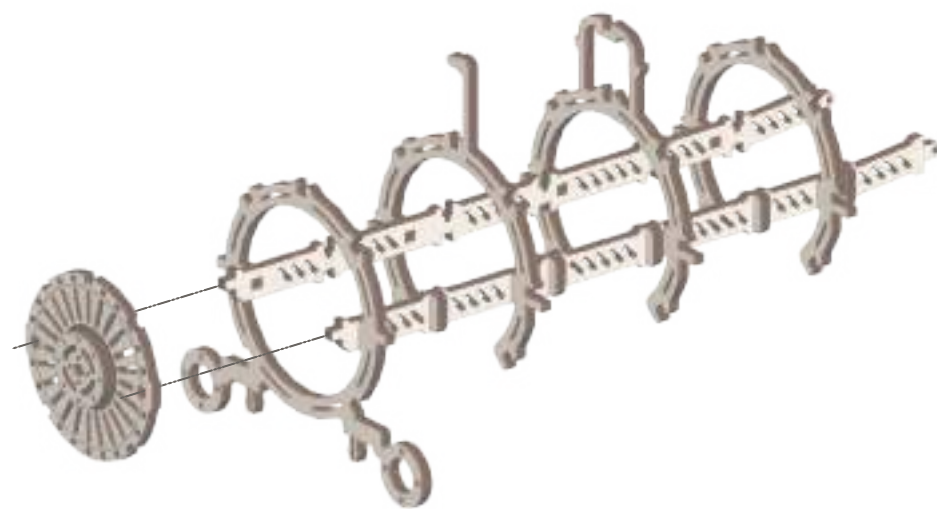
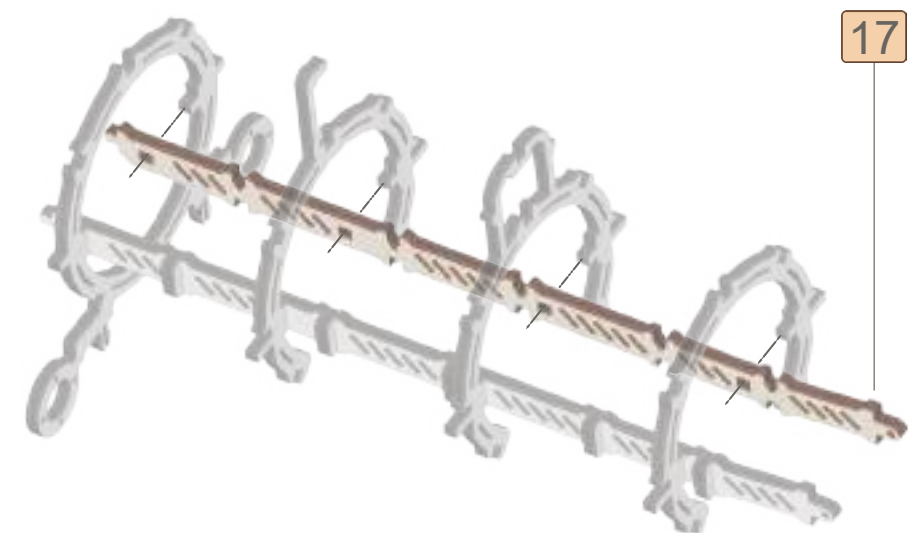
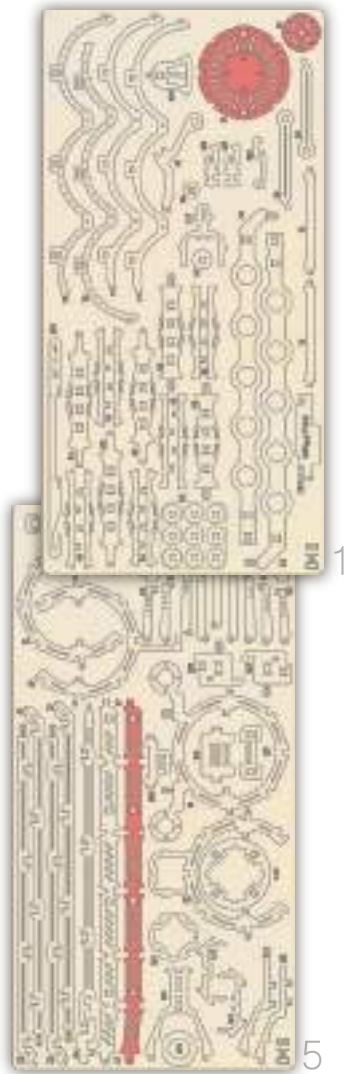

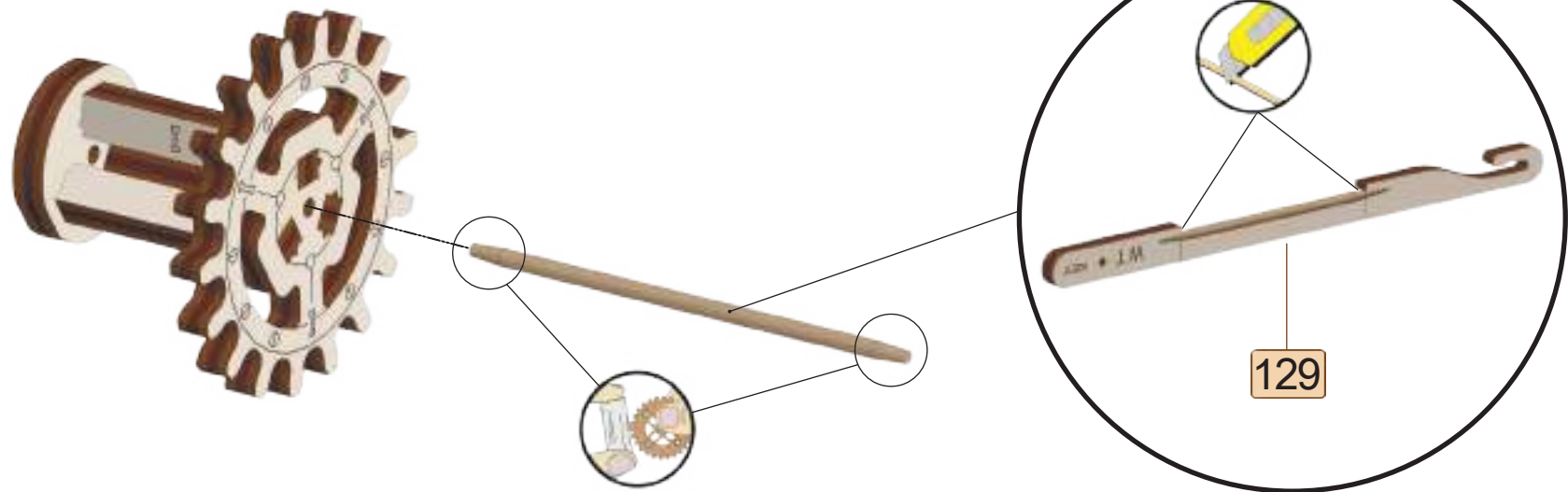
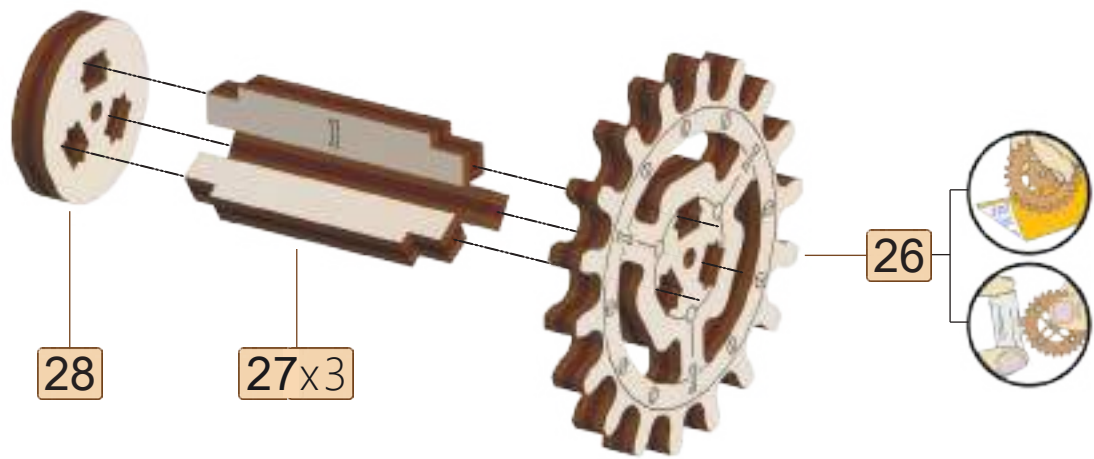
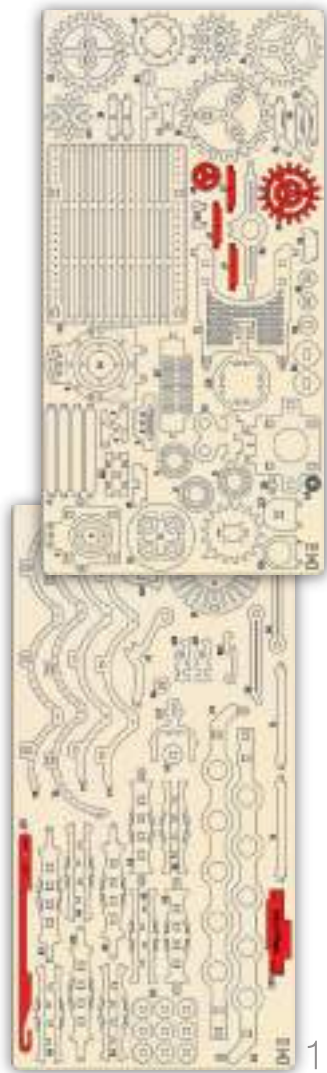



5

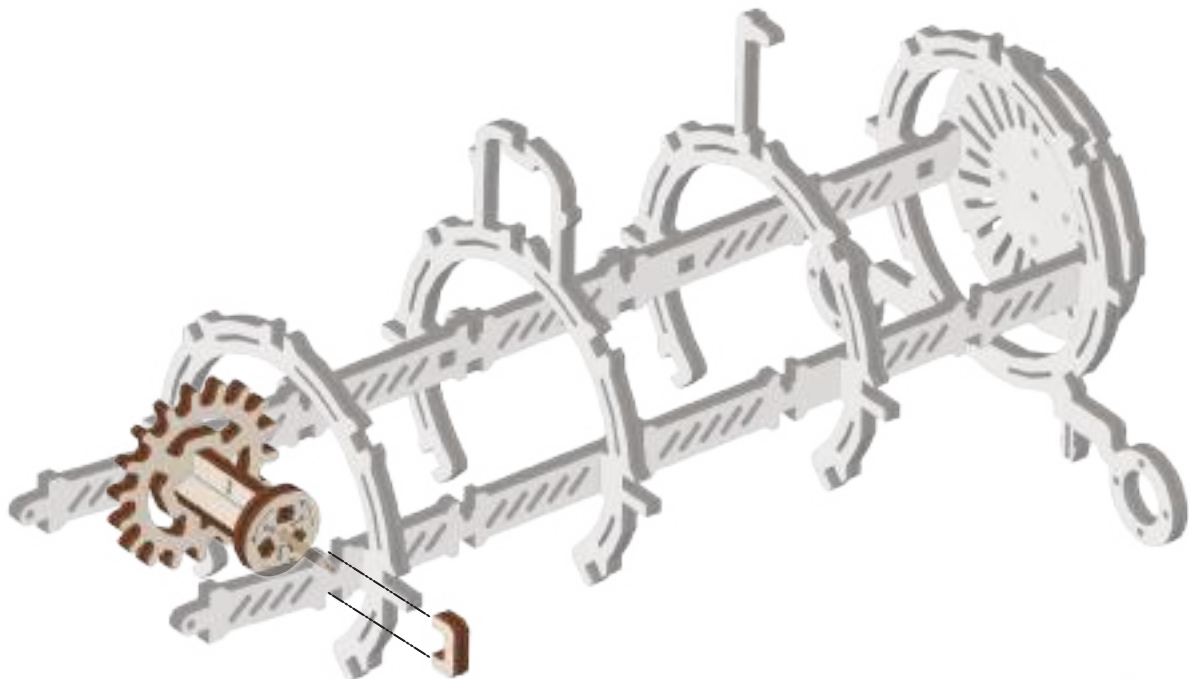

25



[4]

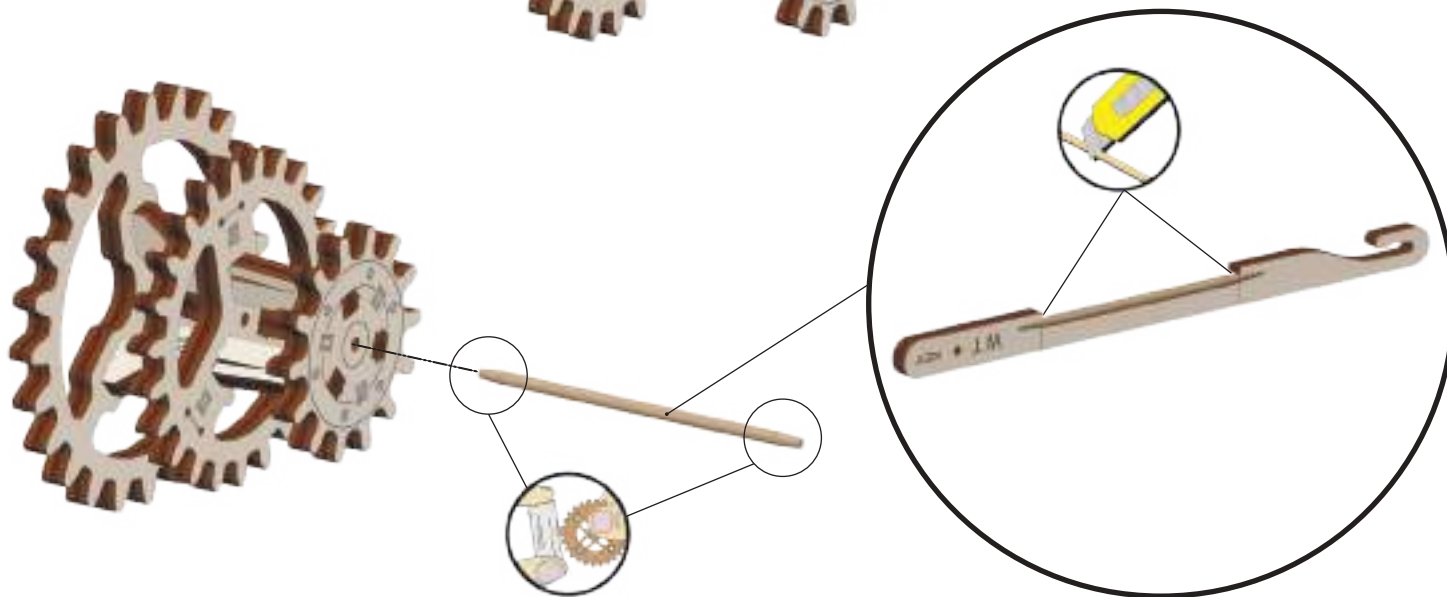
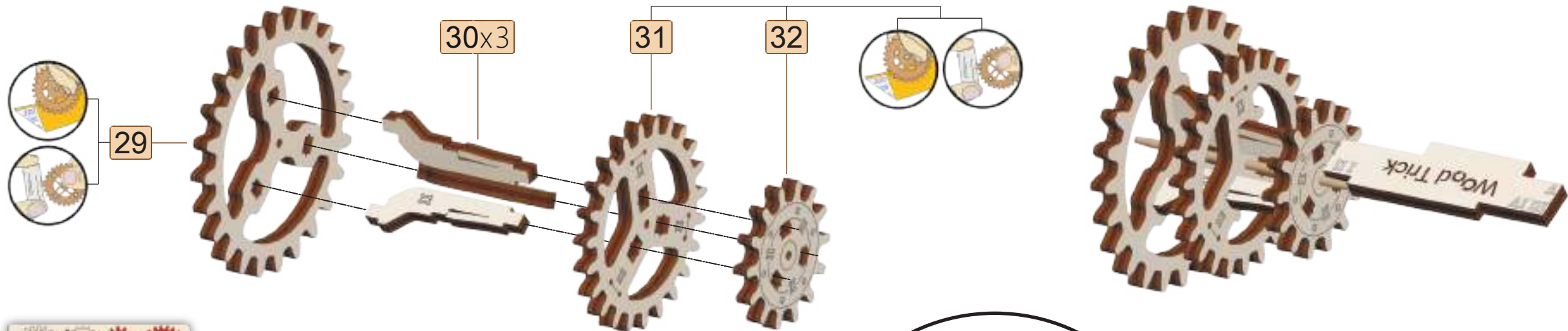



5



25

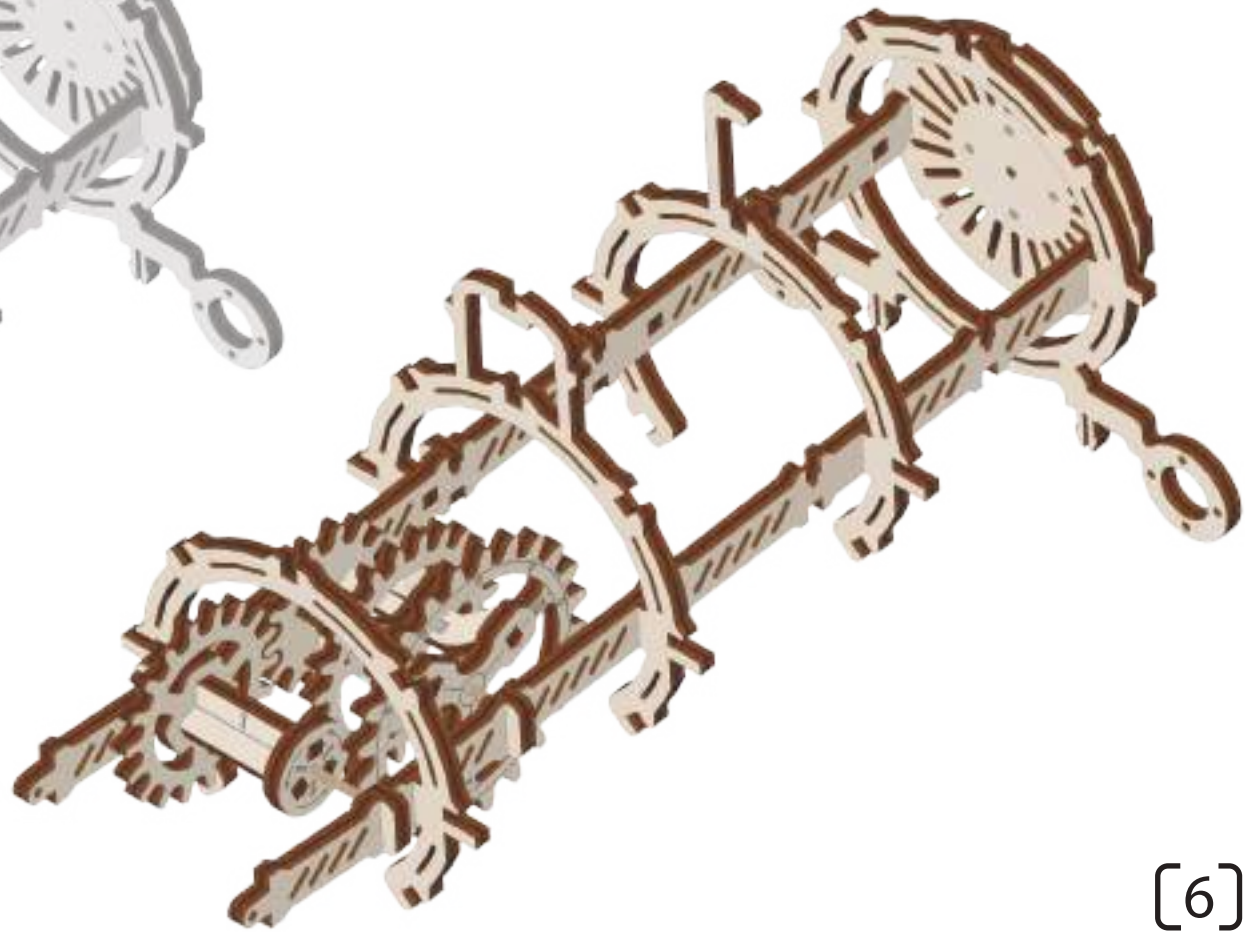

[6]

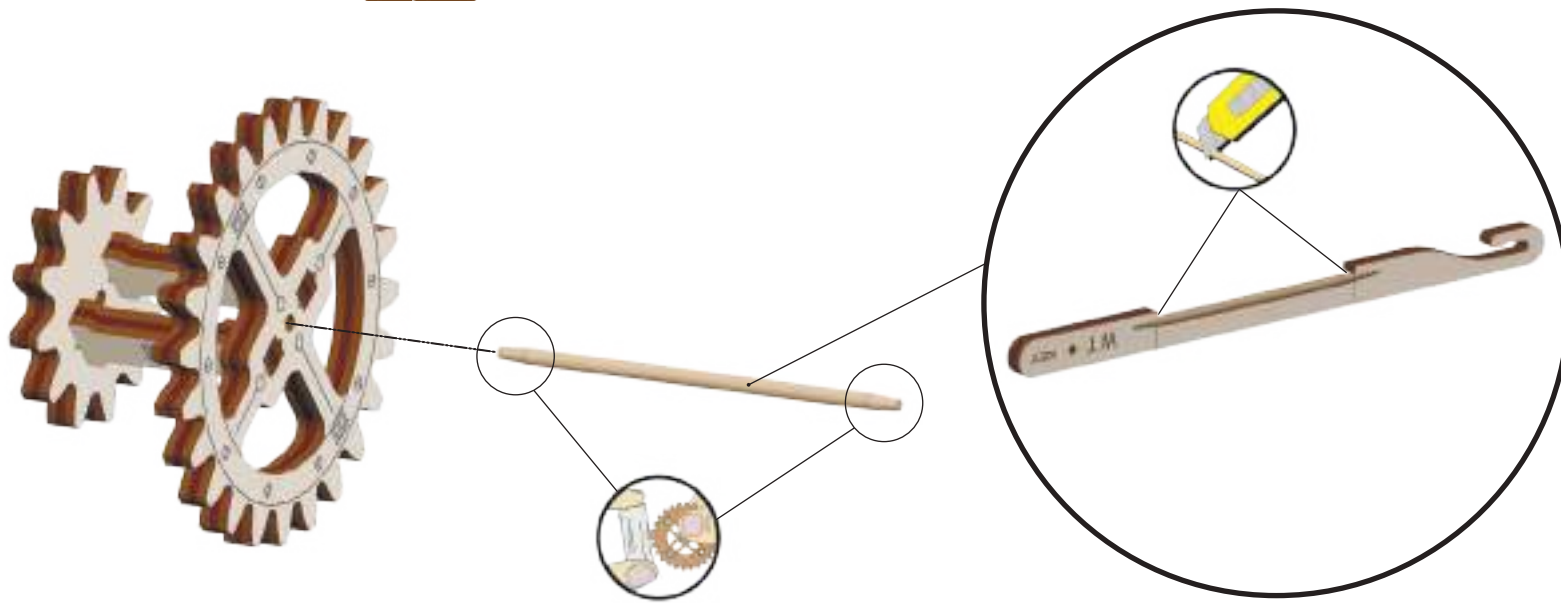
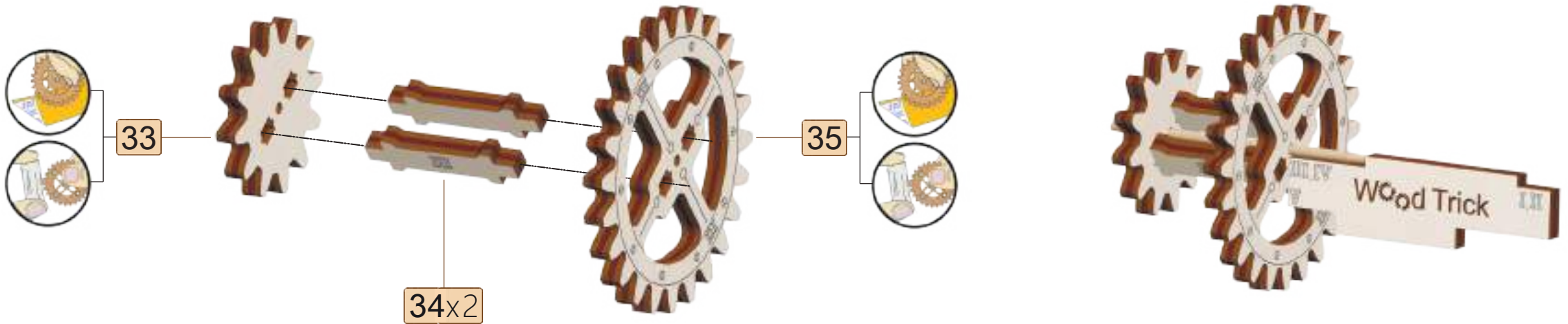





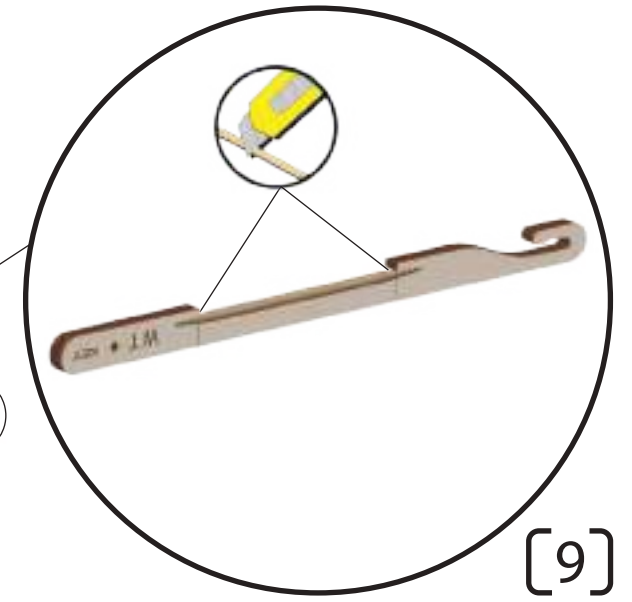
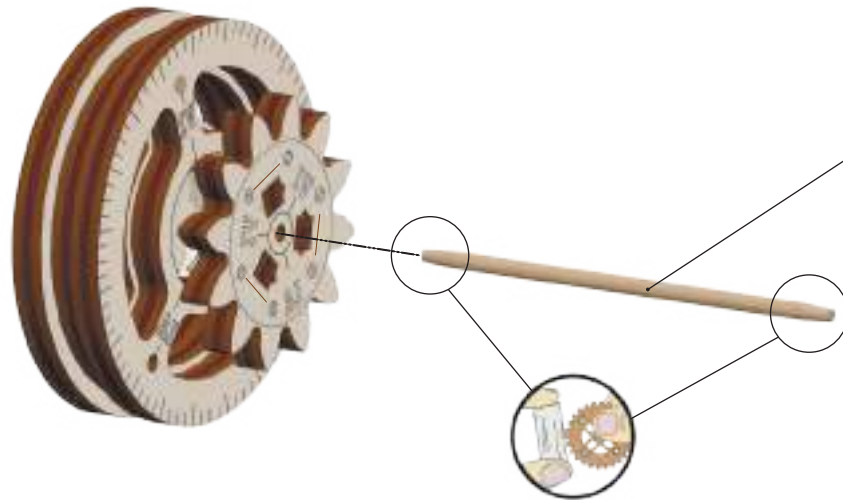
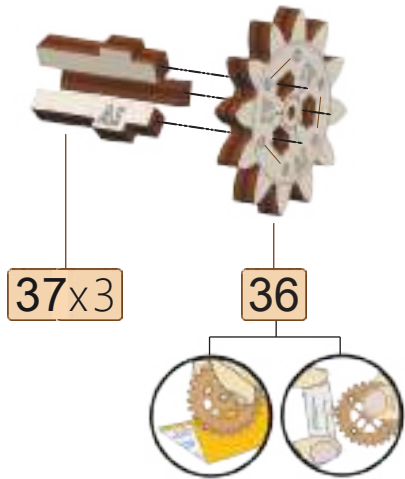
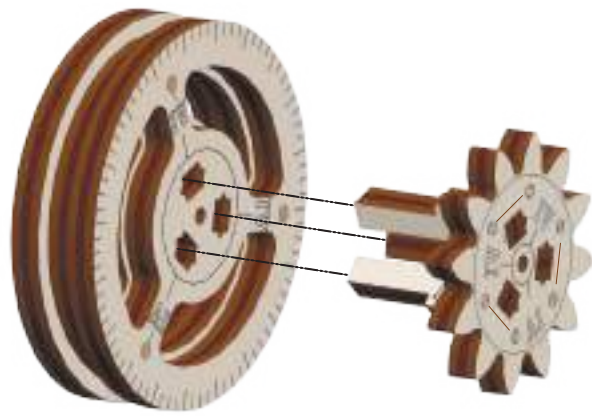
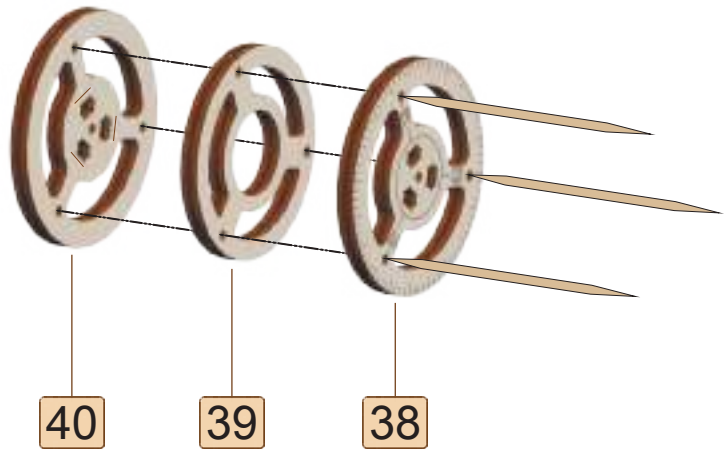

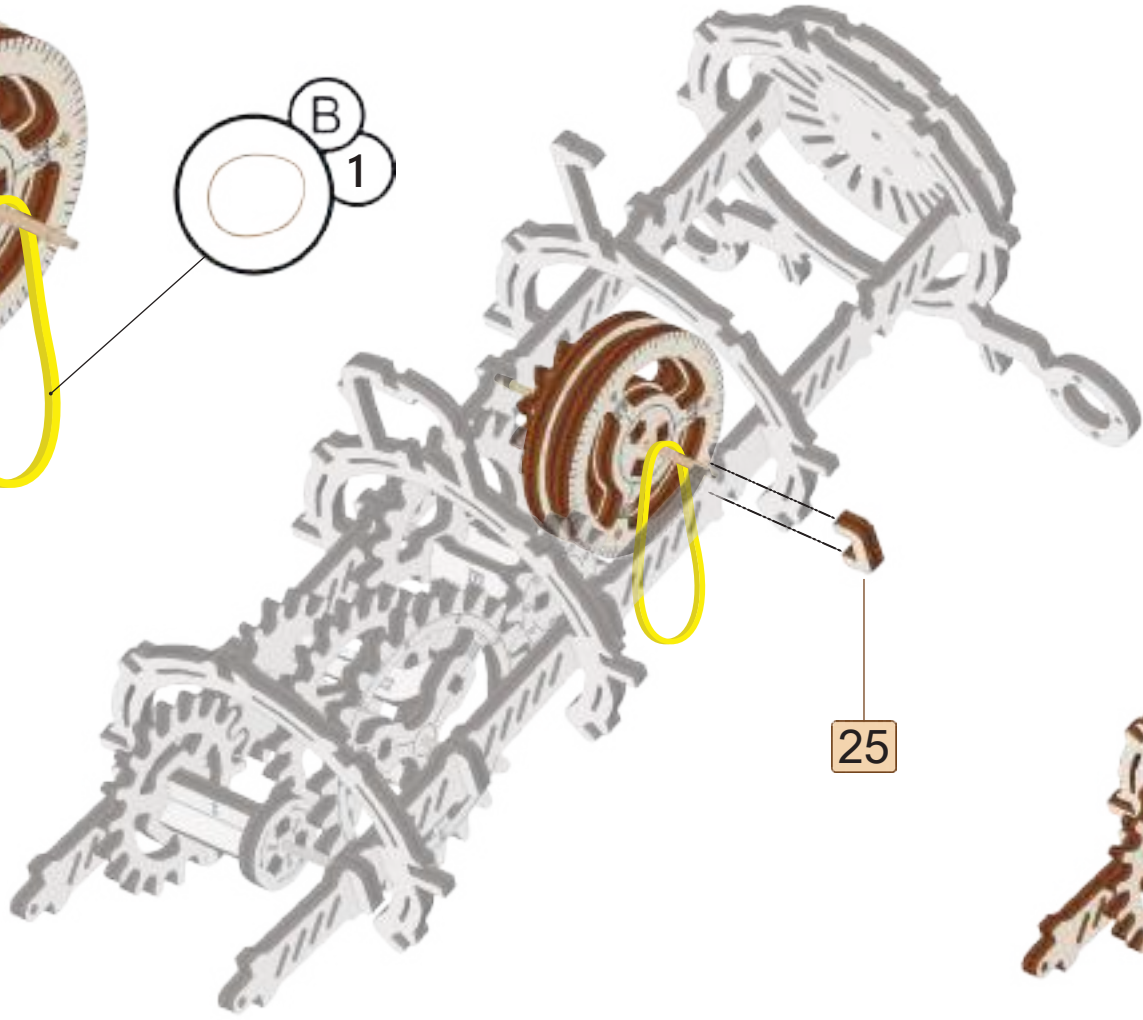
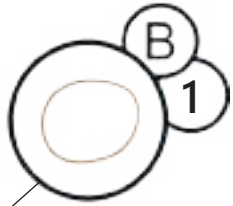
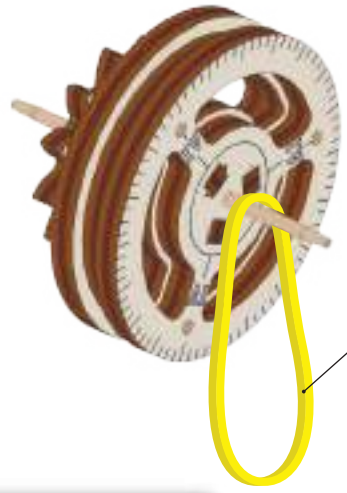

25

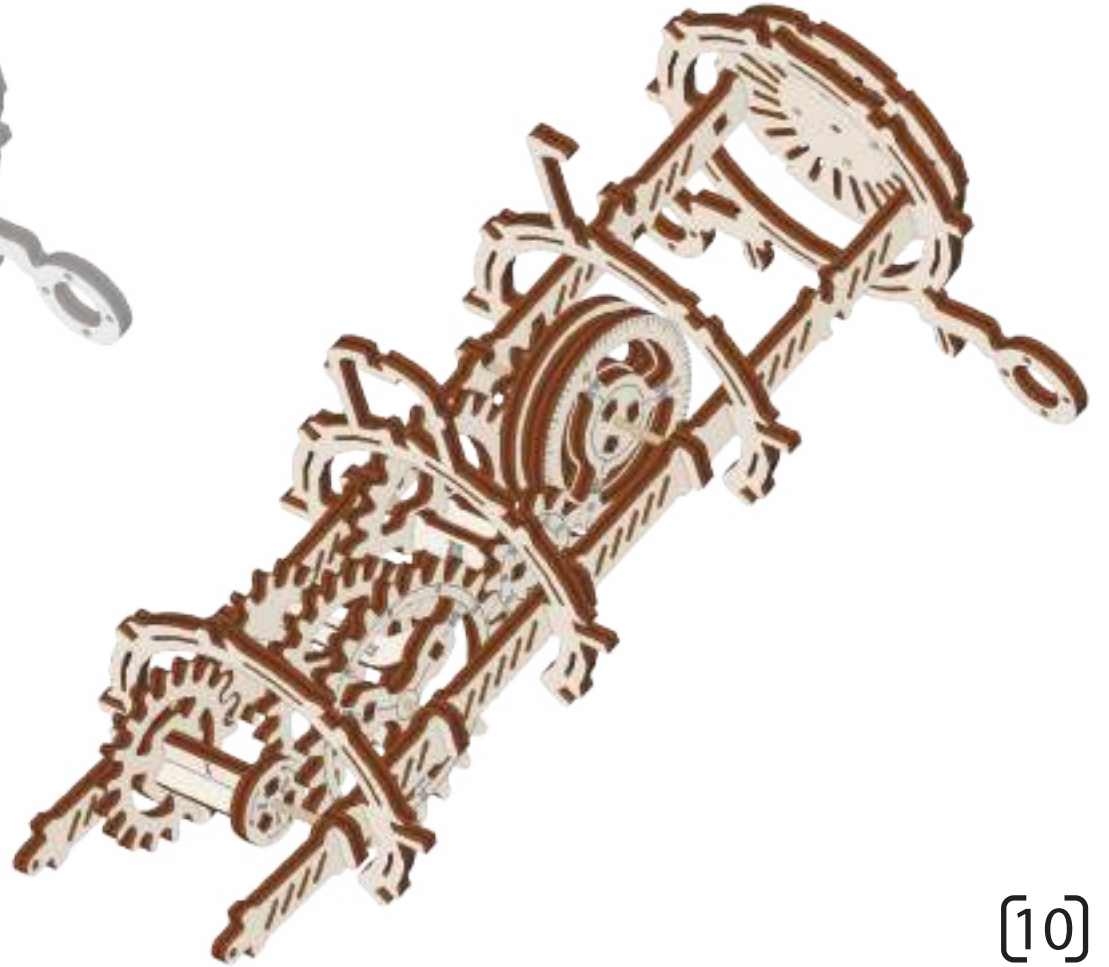

[10]

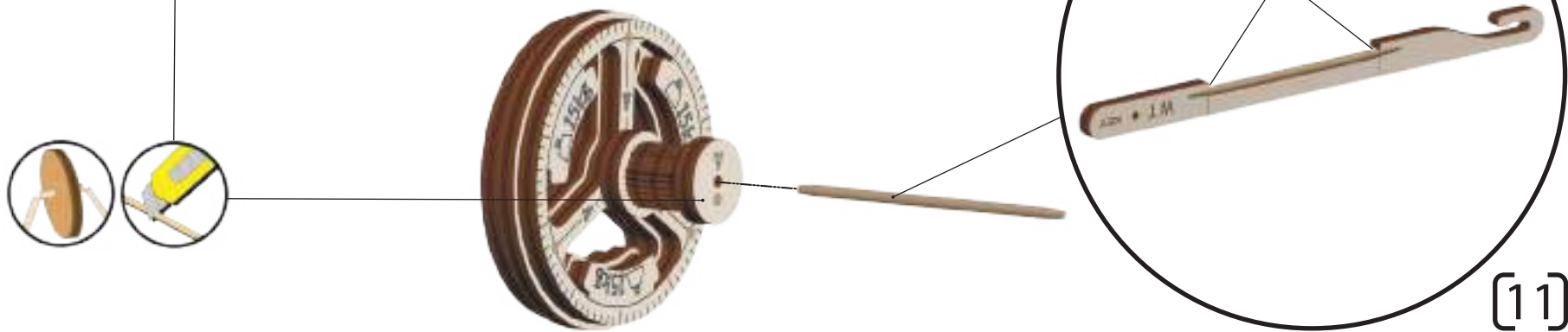
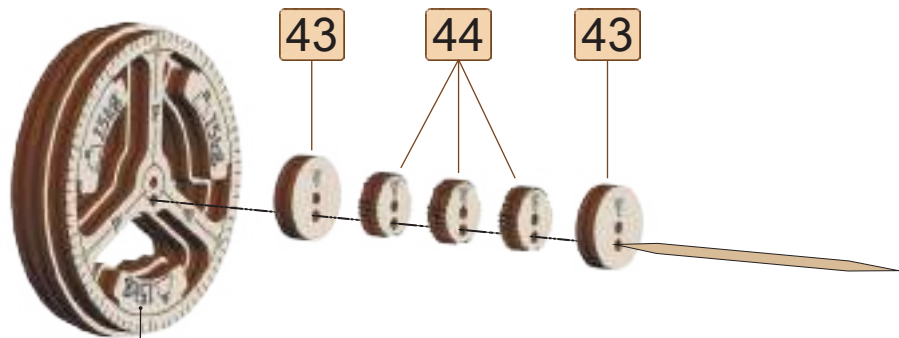
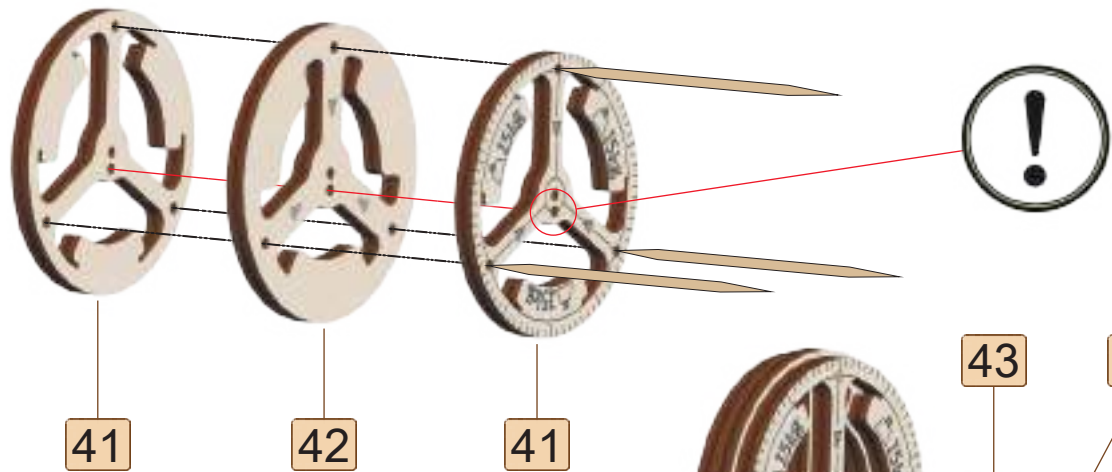

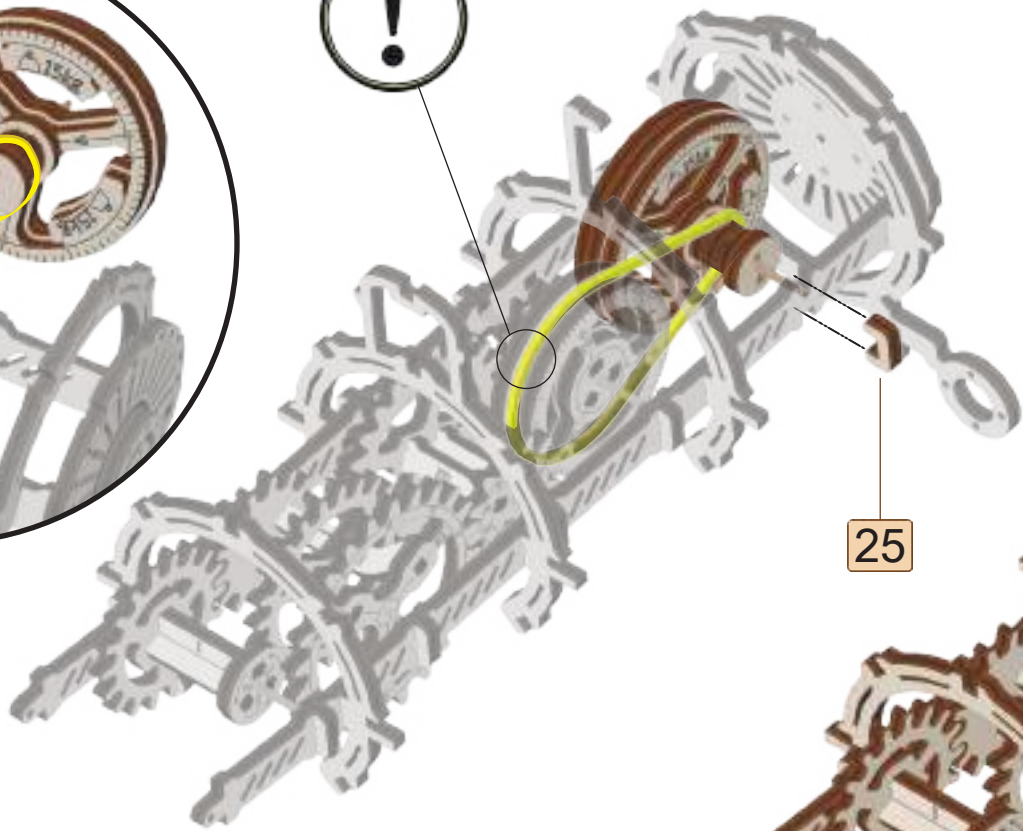
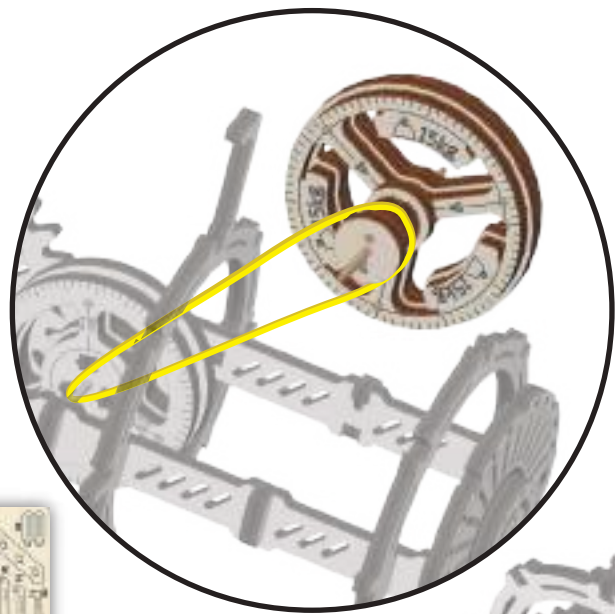

25

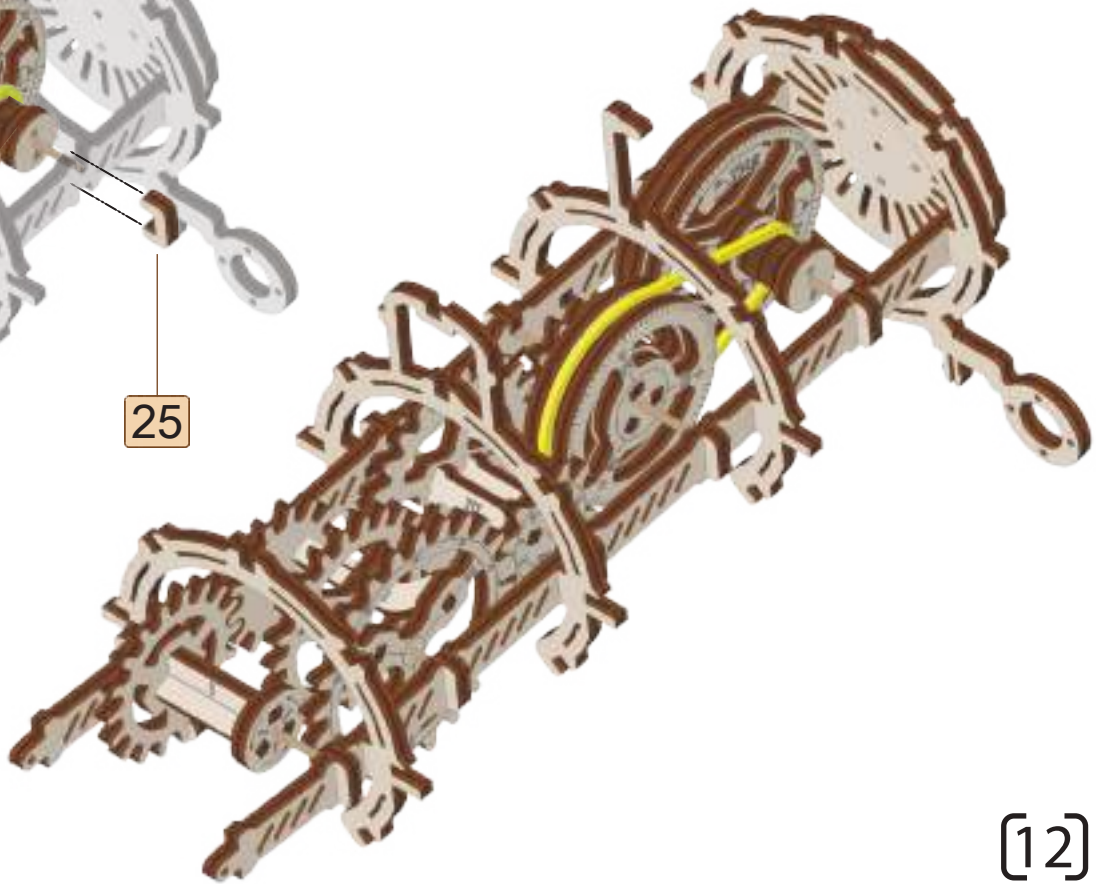

[12]



5

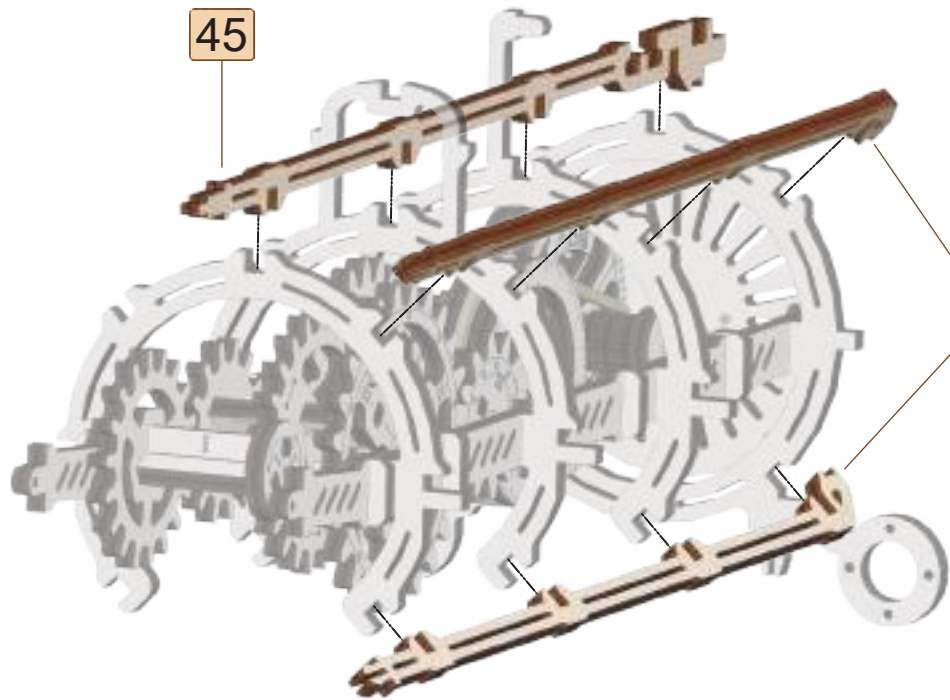

22

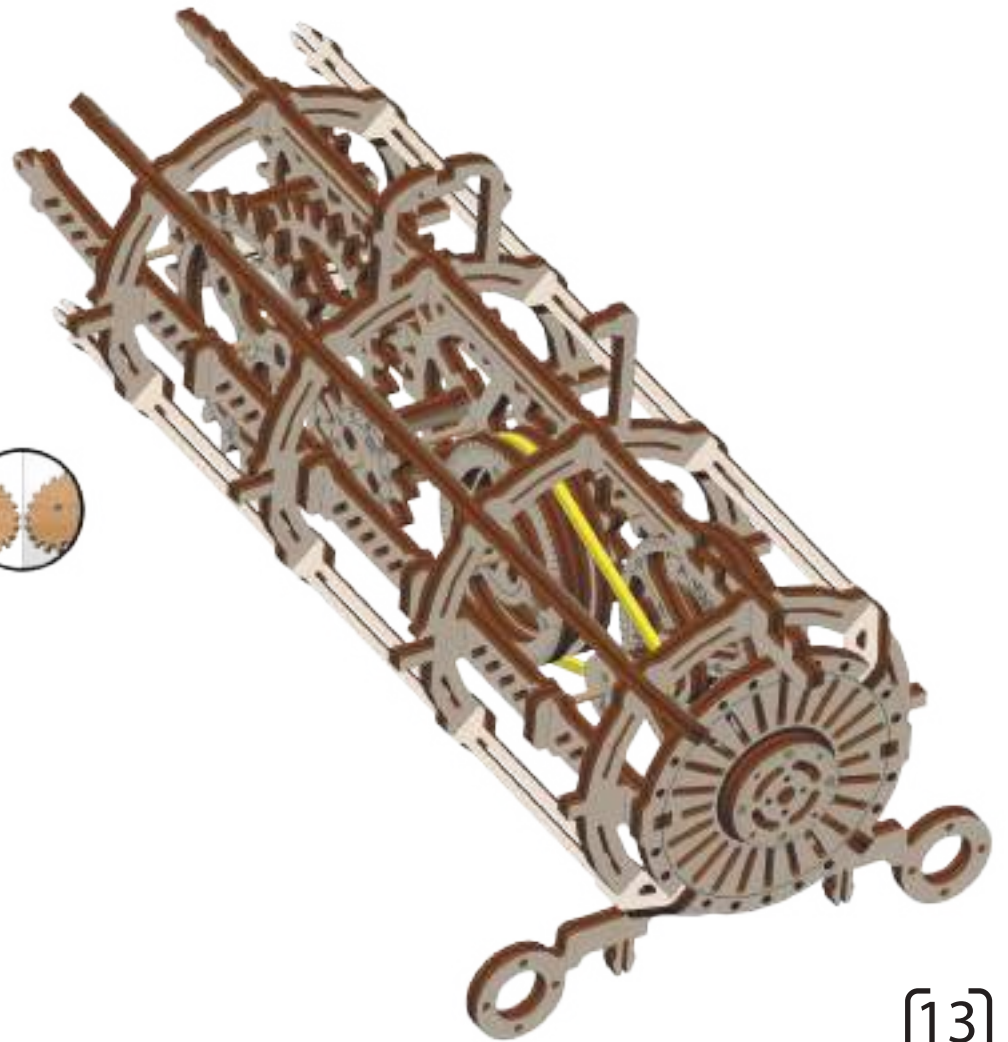
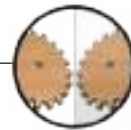

[13]



3

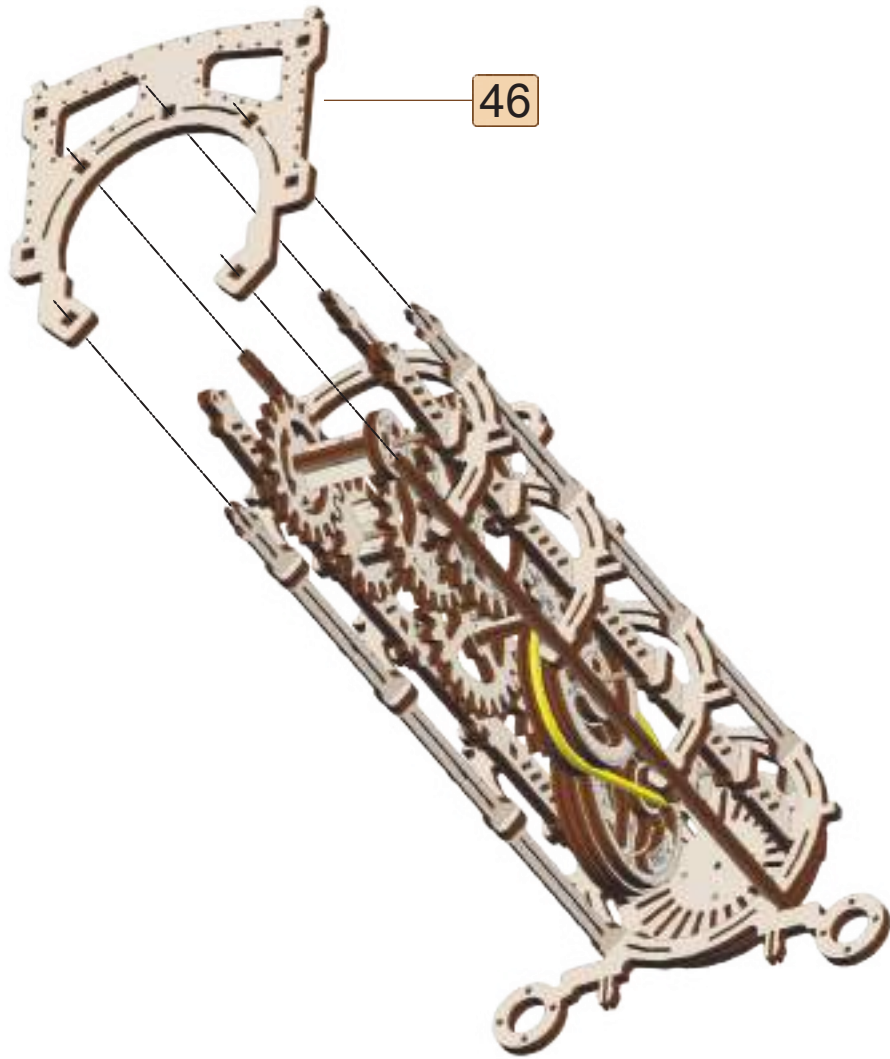

[14]

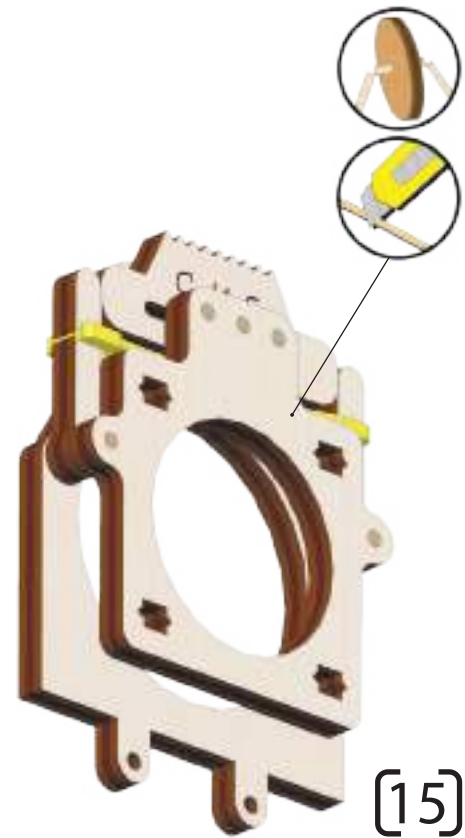
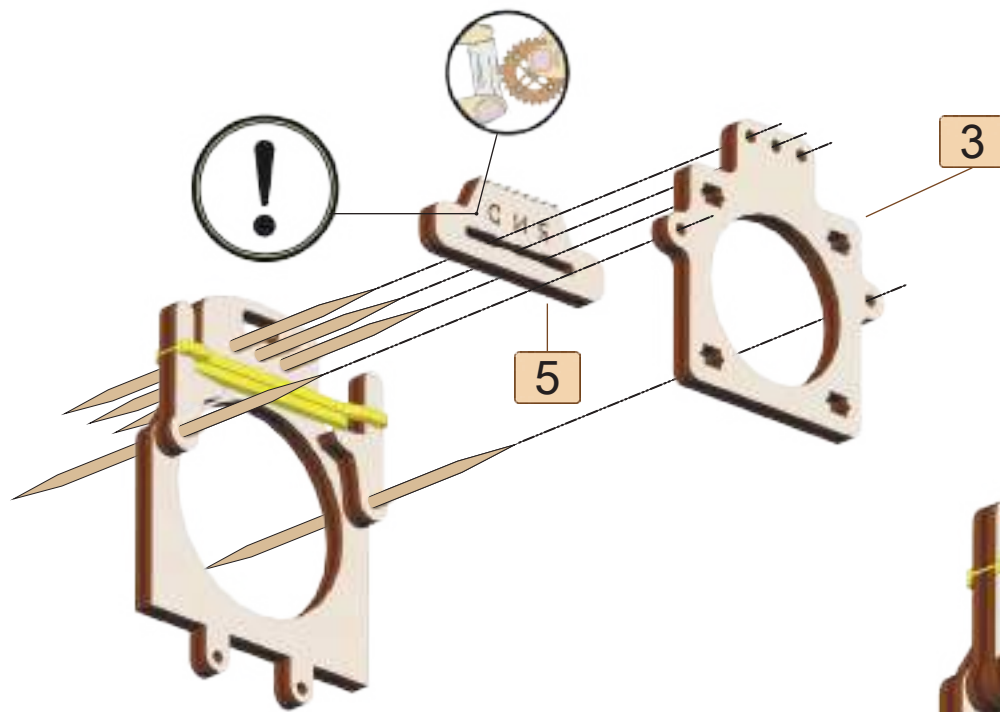
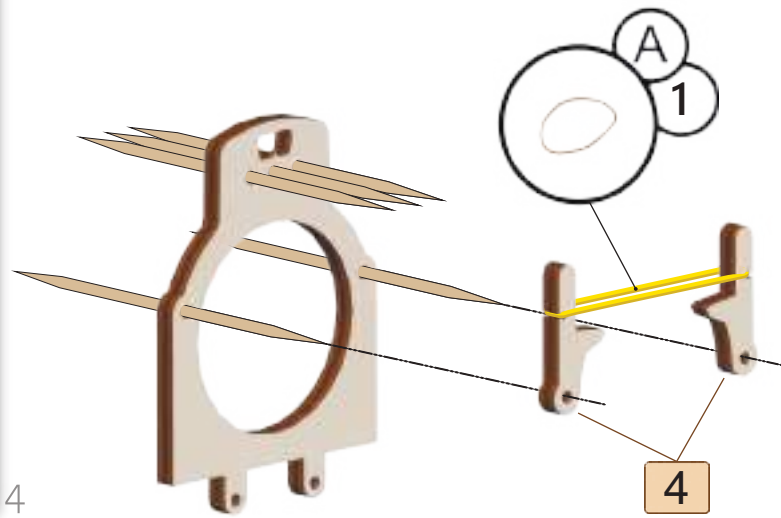
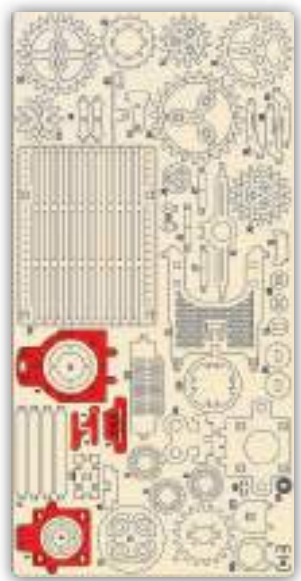
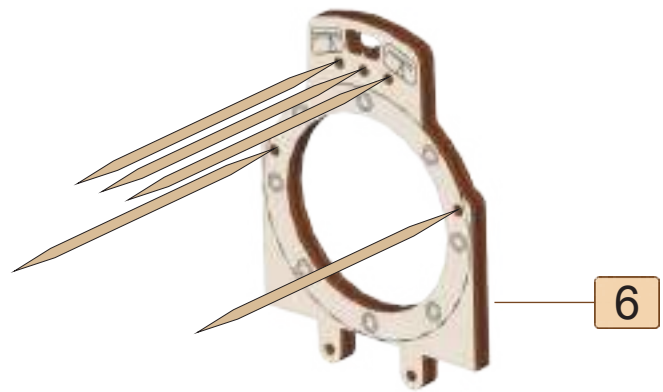



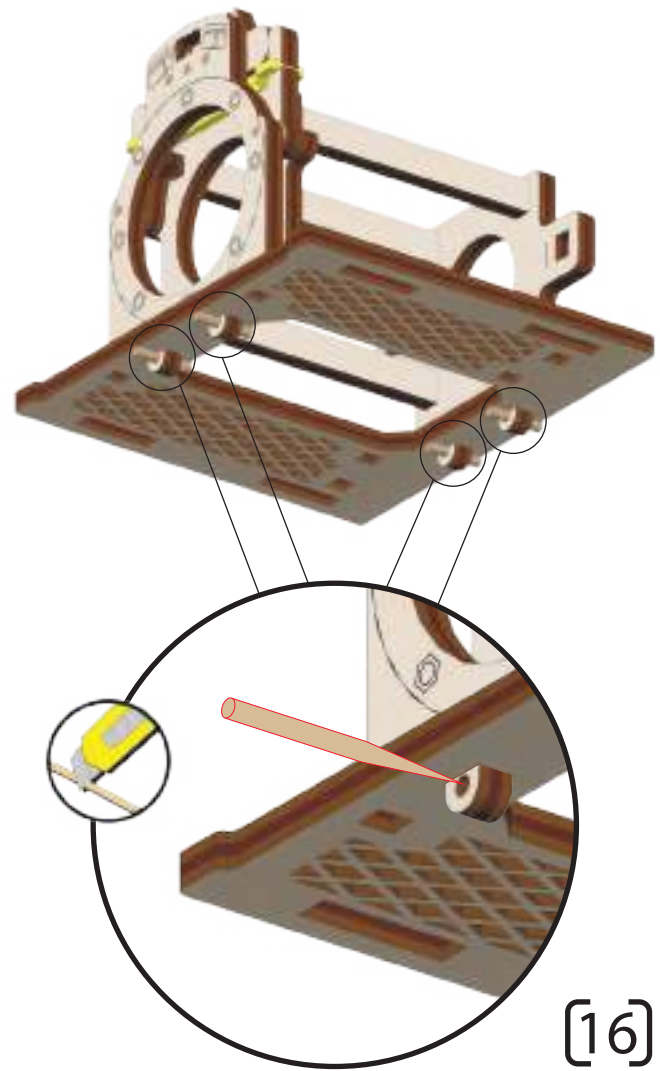
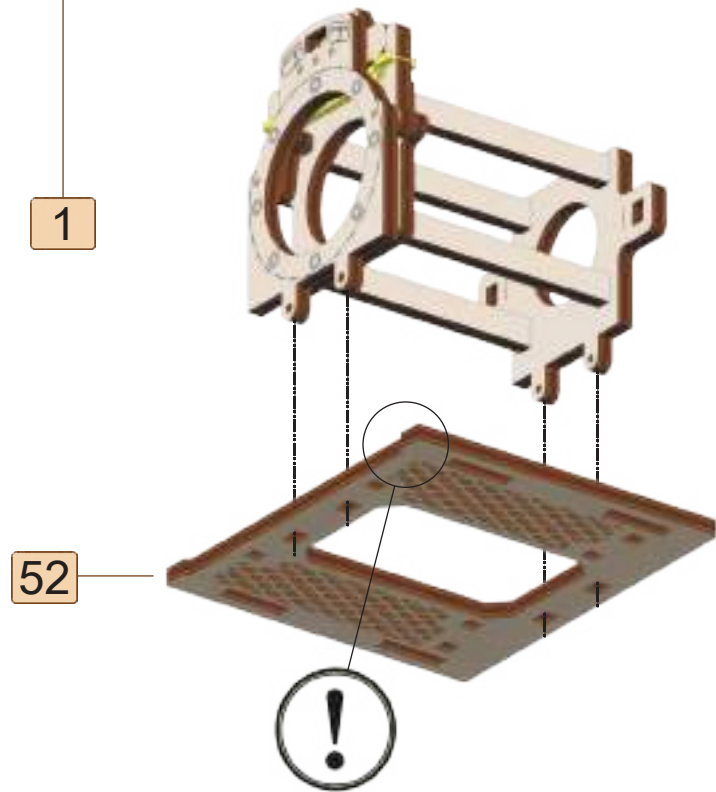
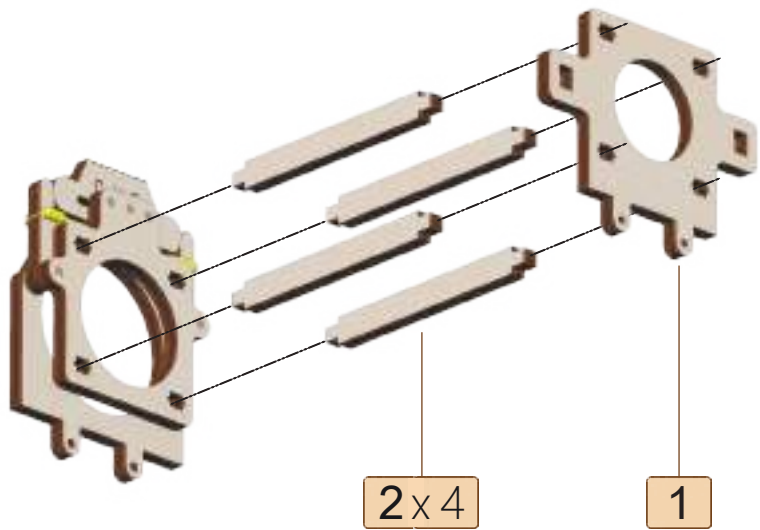
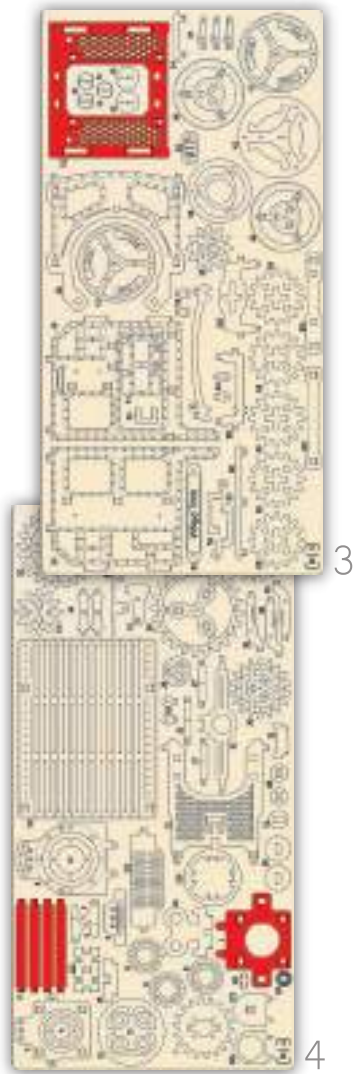



4

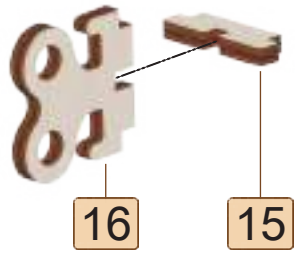

16

15

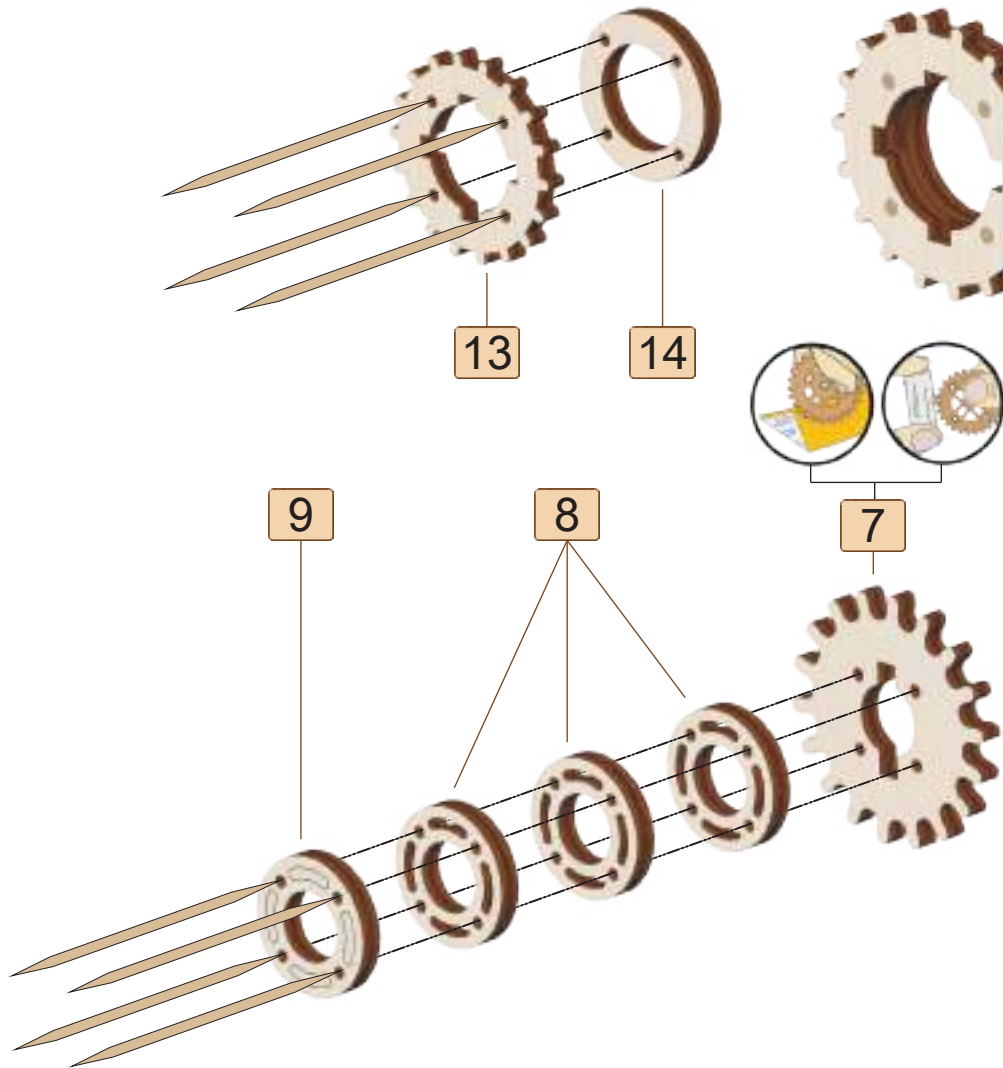

9

8

7

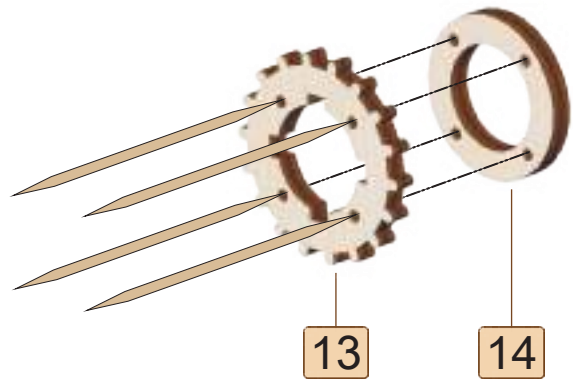

13

14



7

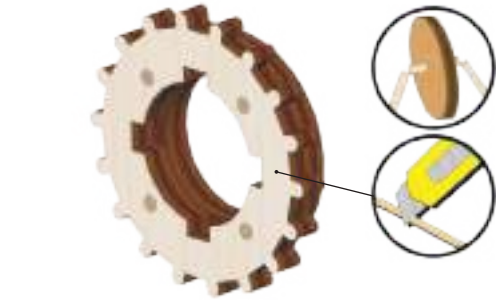

10

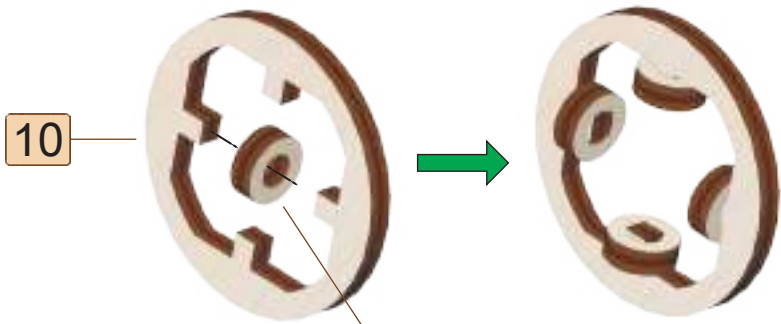

11x4

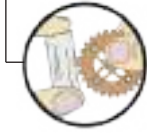
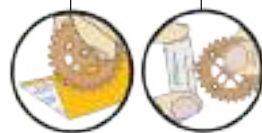

[17]

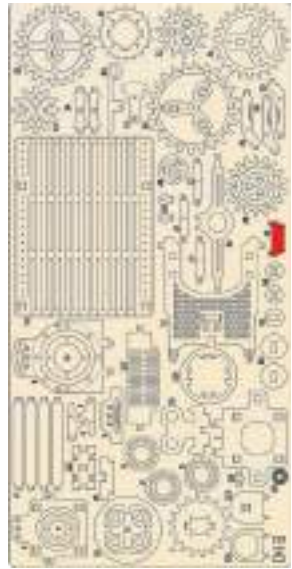
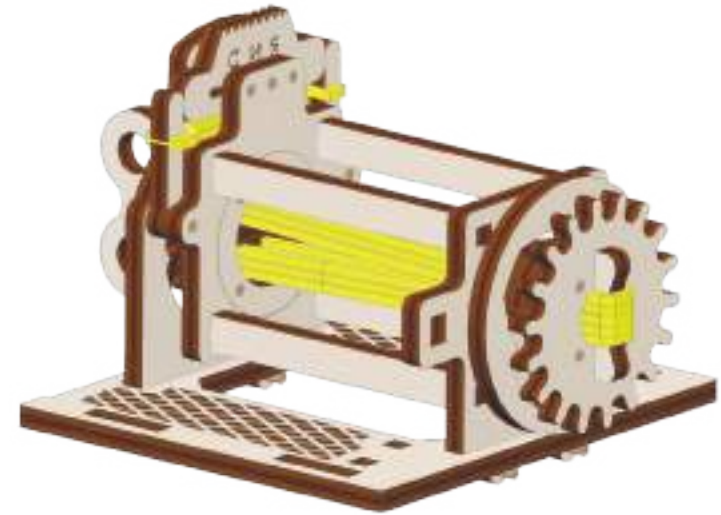
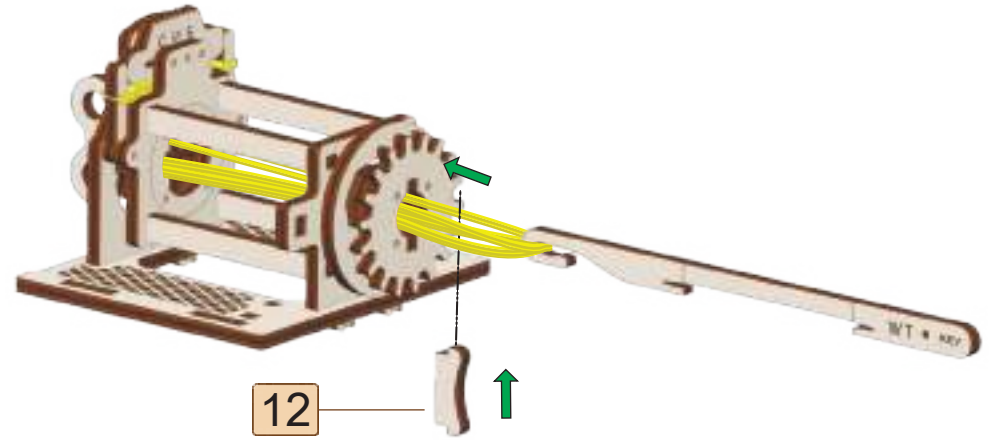
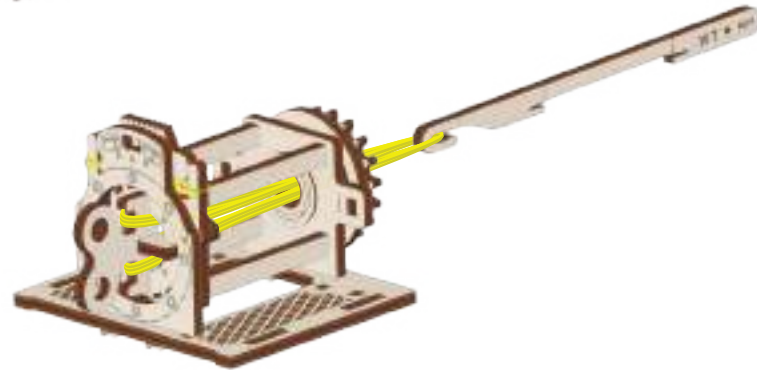
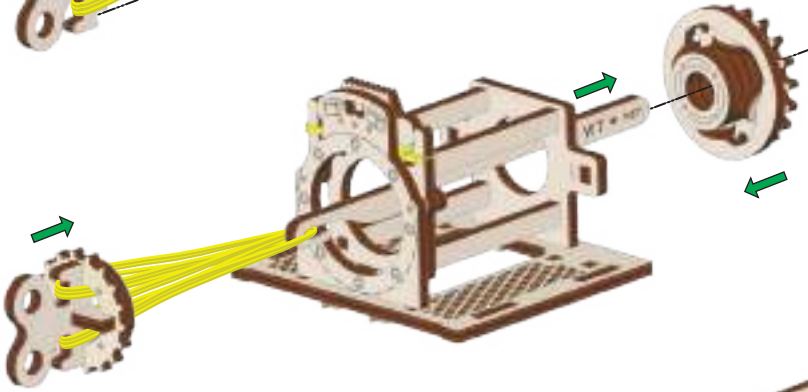
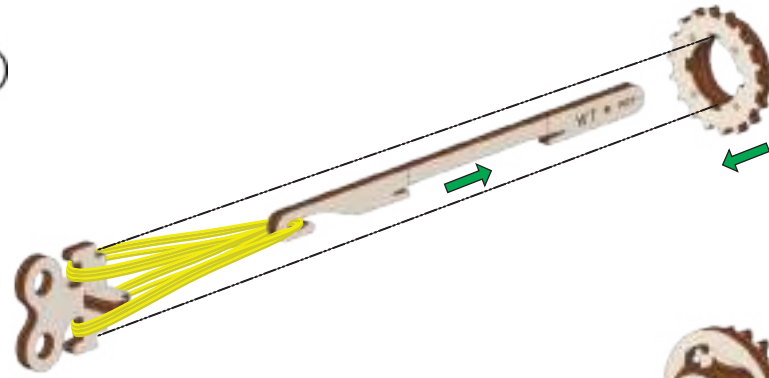
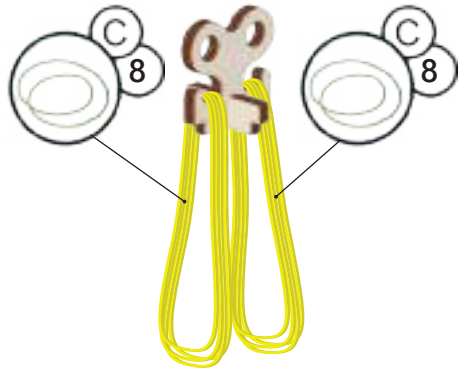

4

[18]

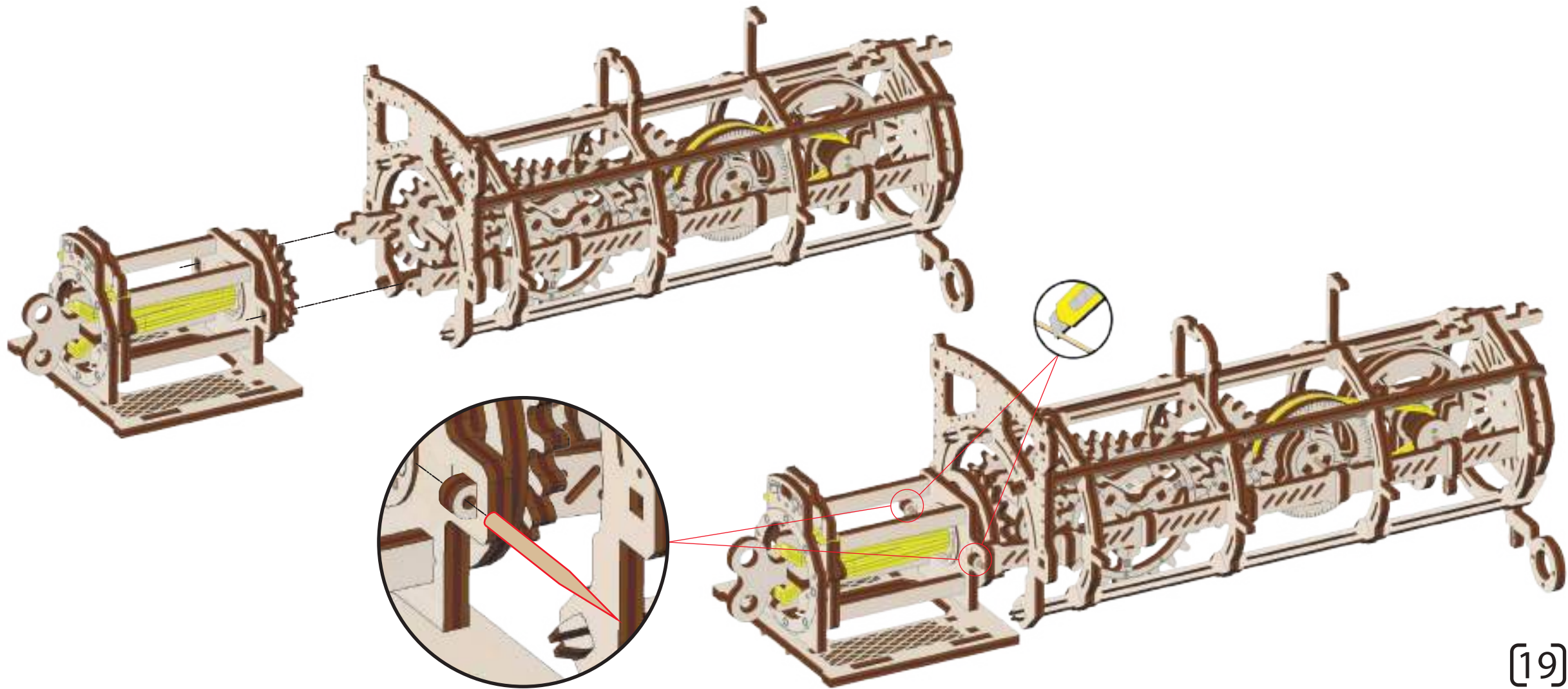

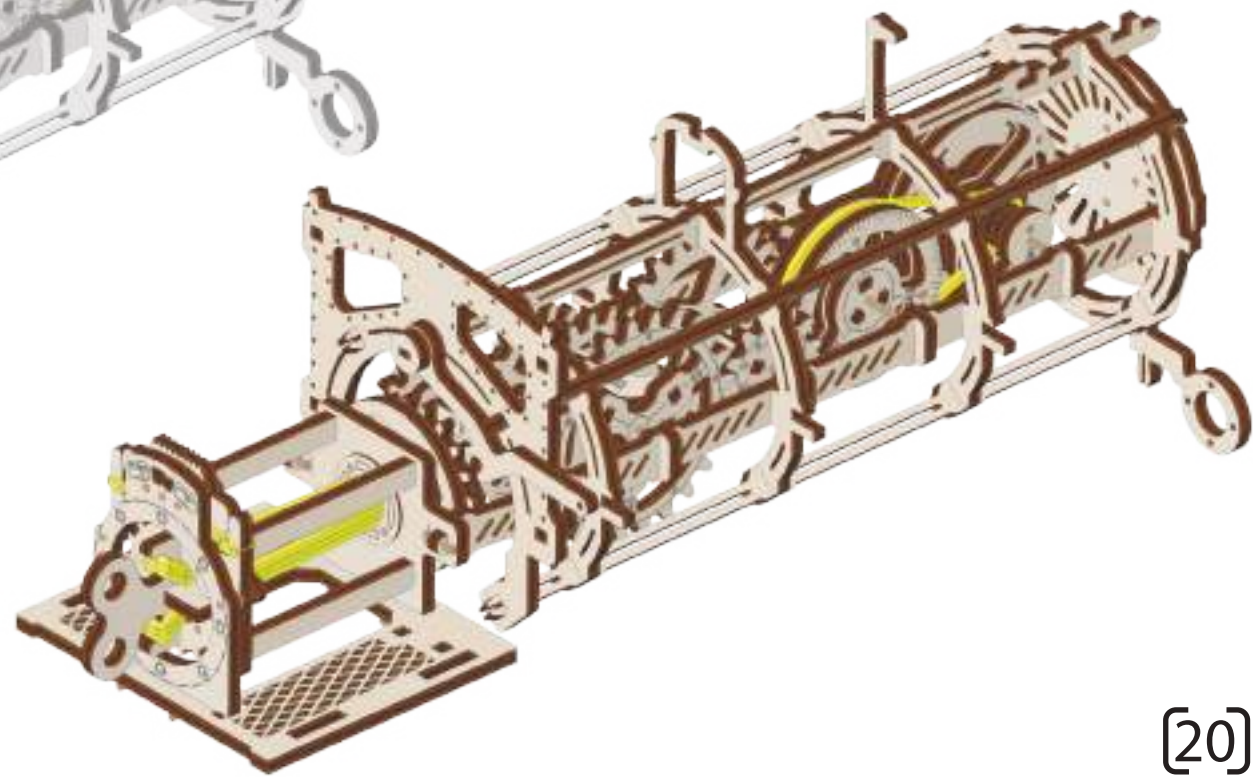
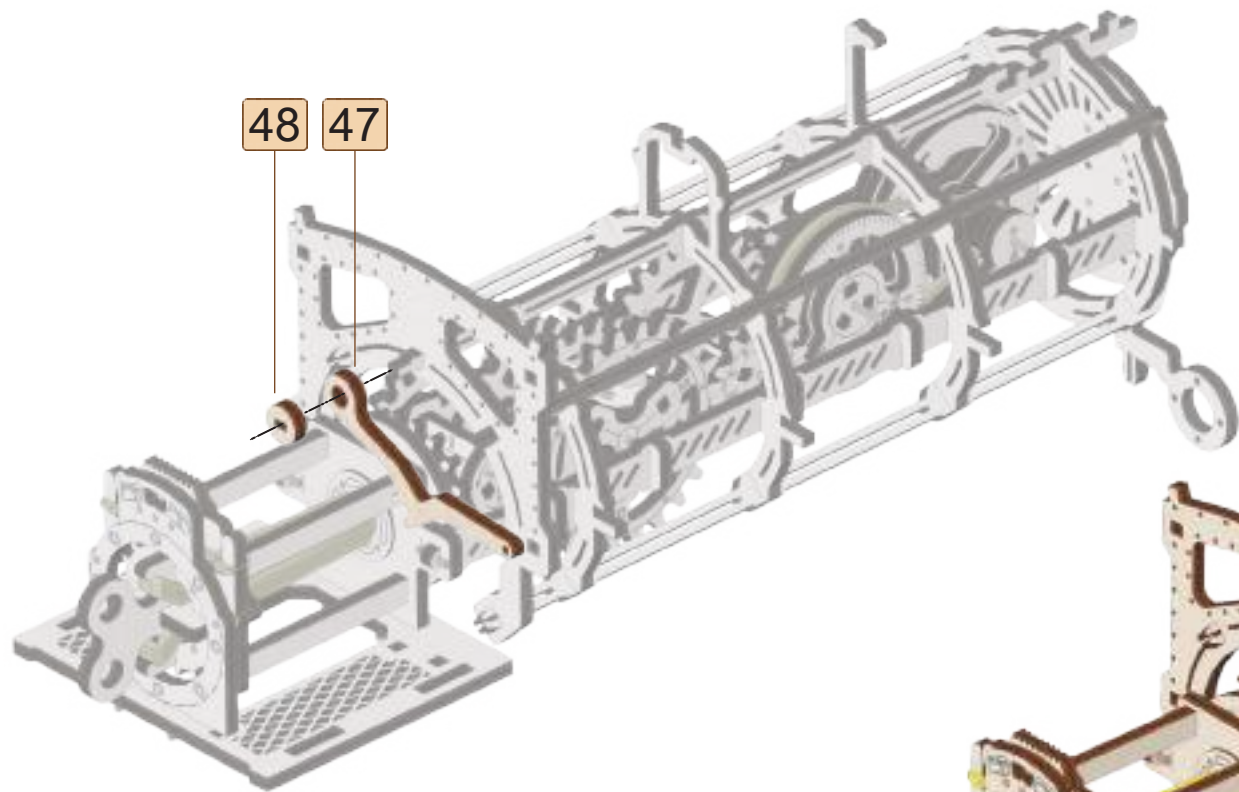
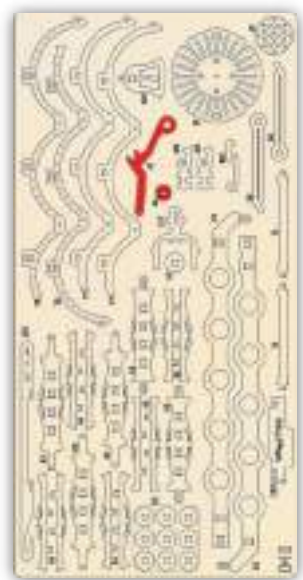

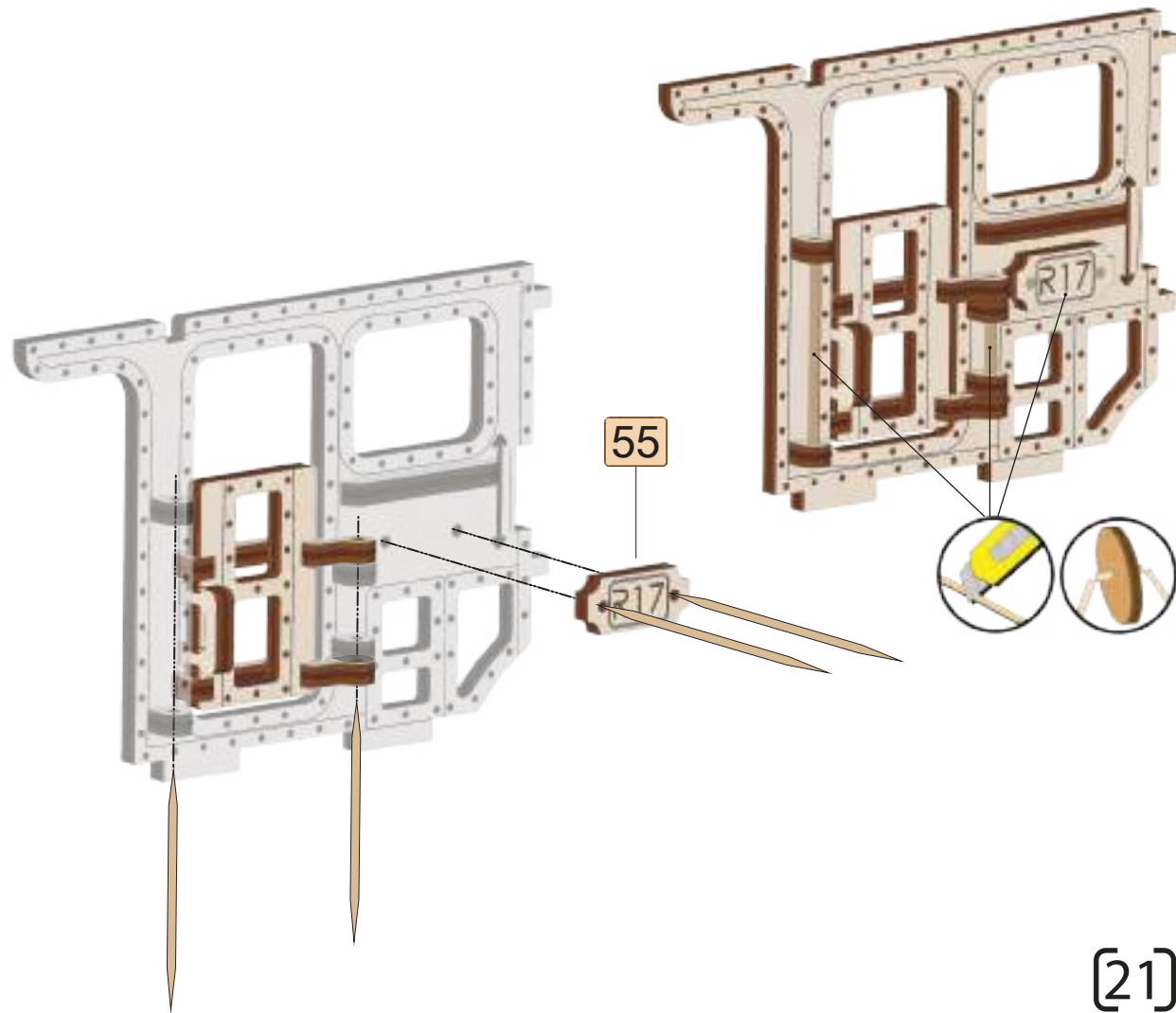
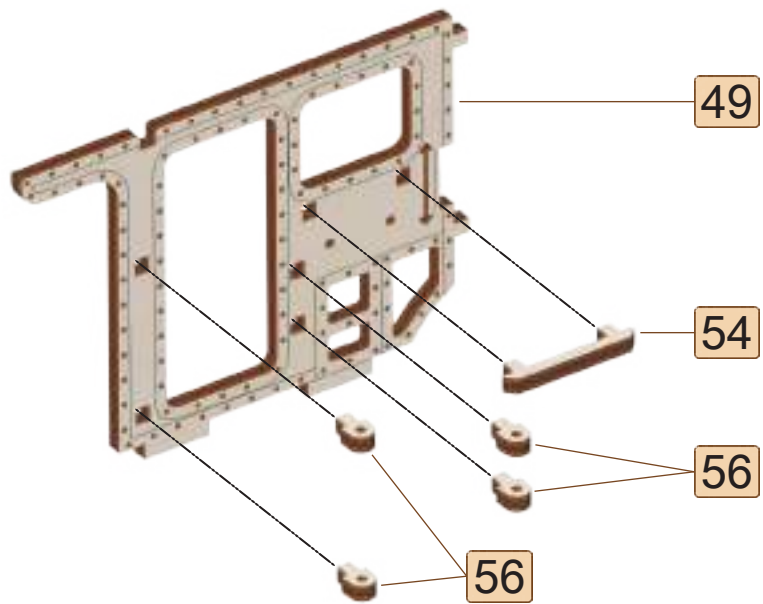
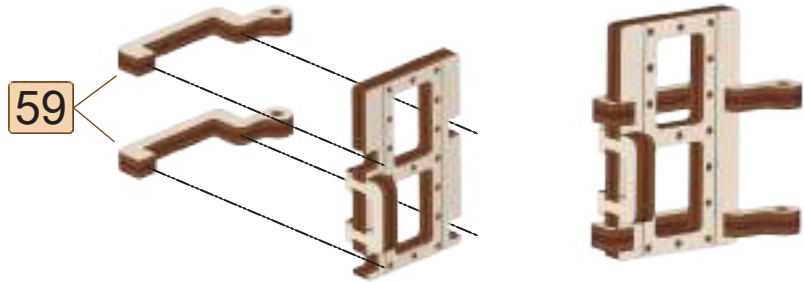
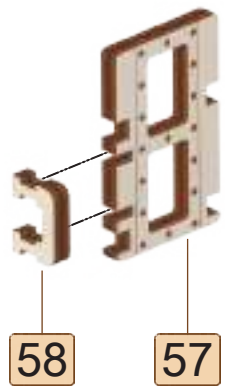

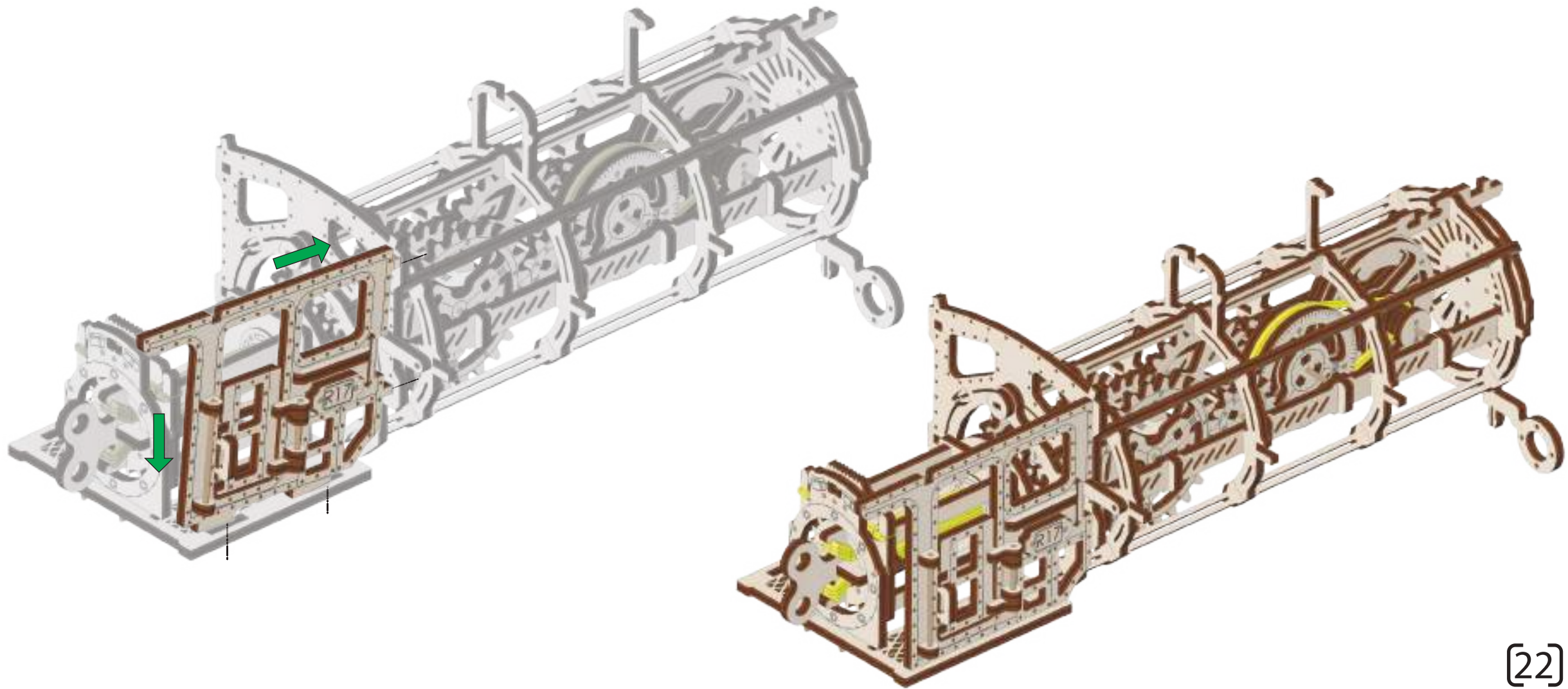

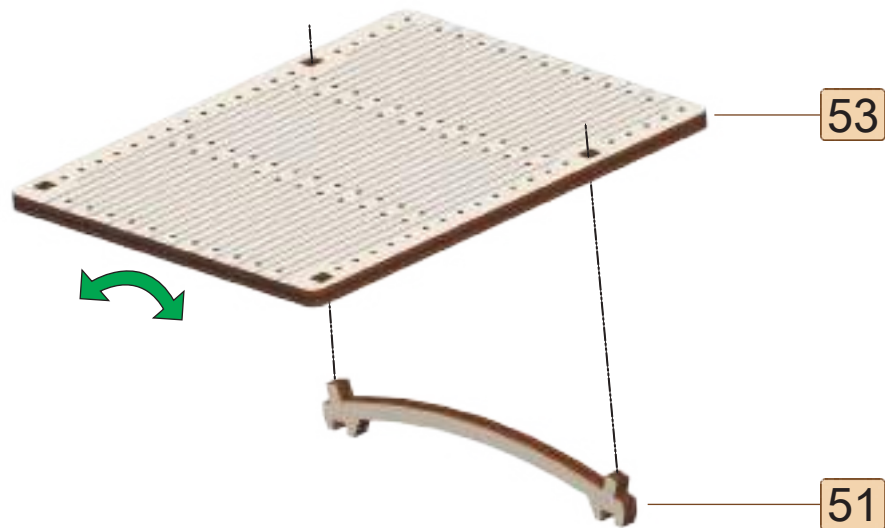
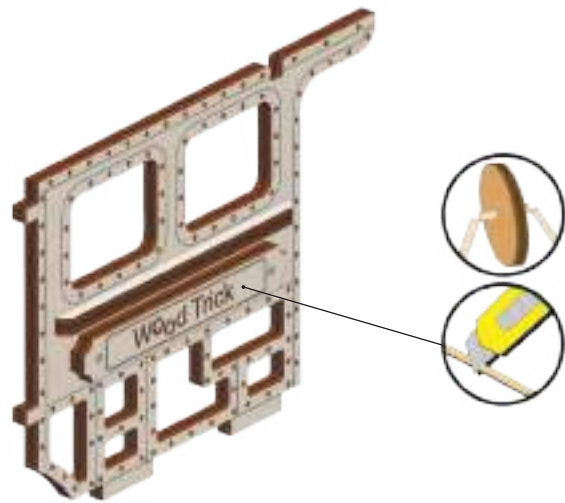
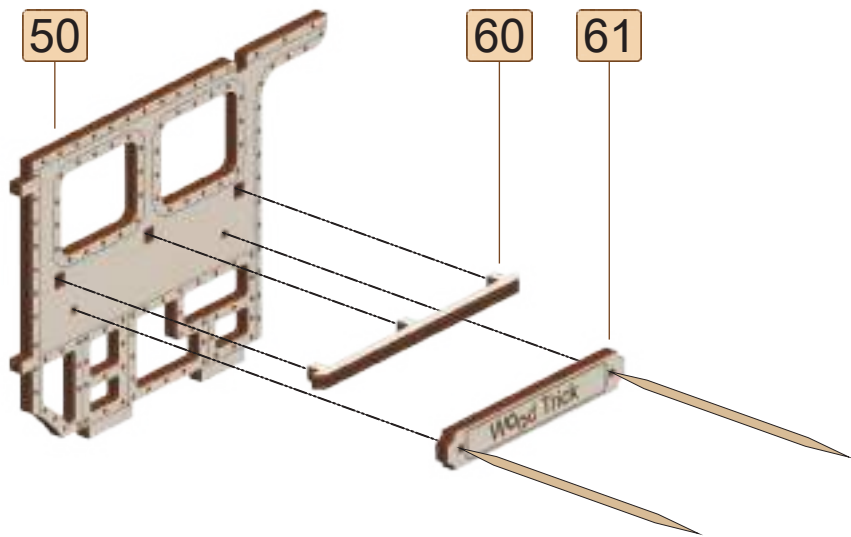



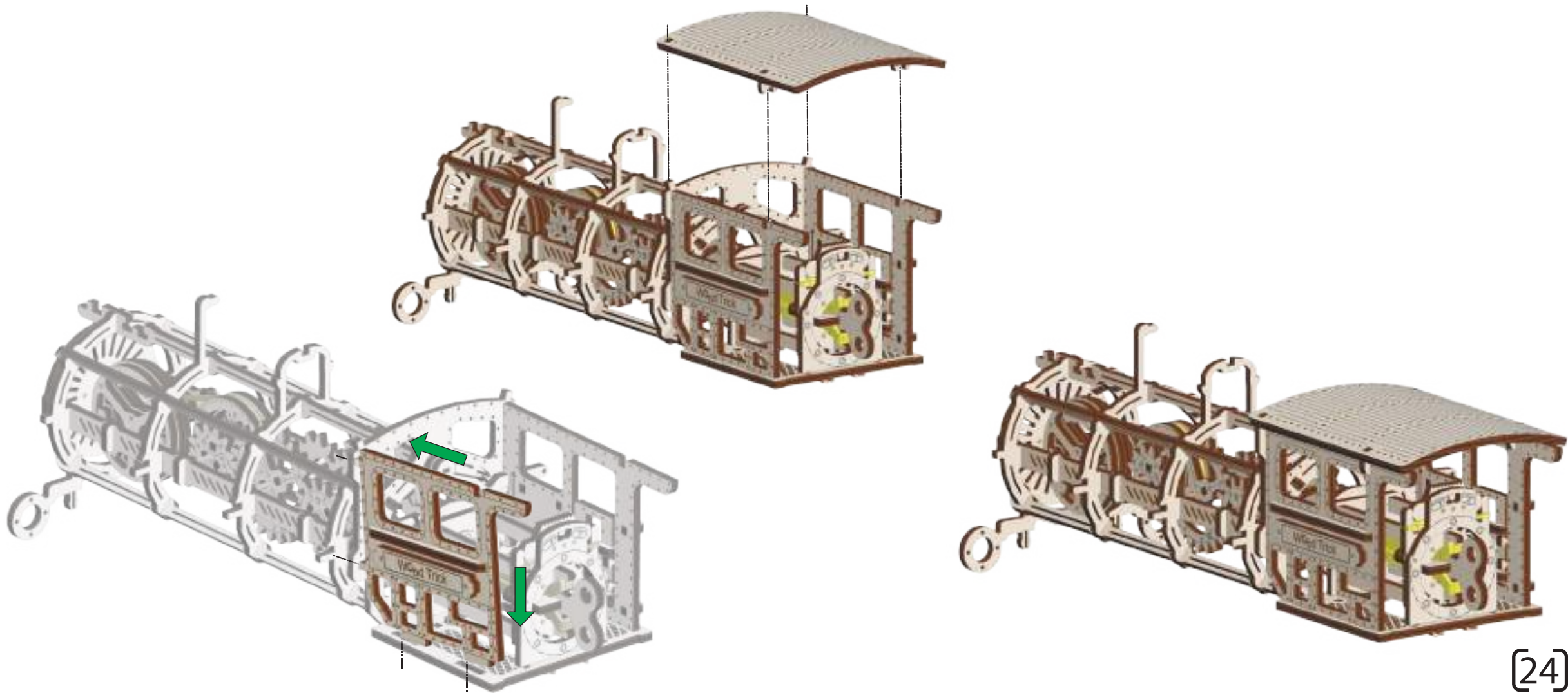

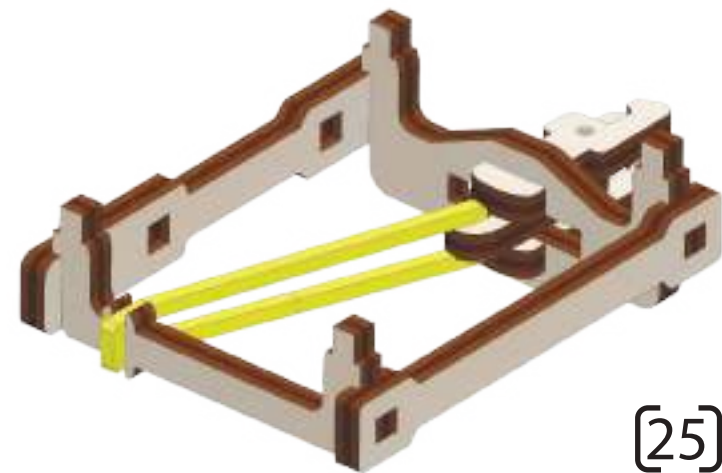
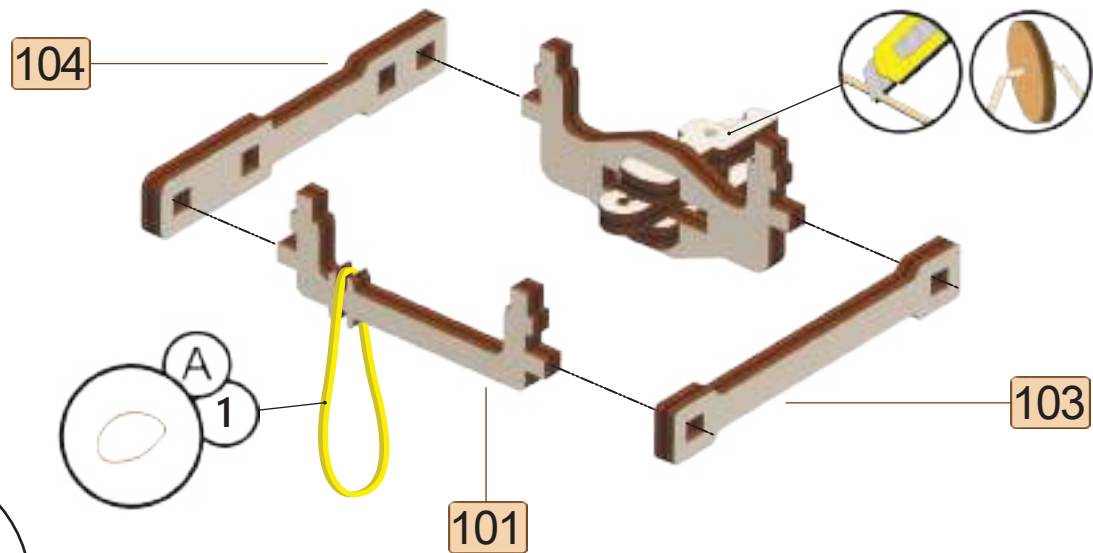
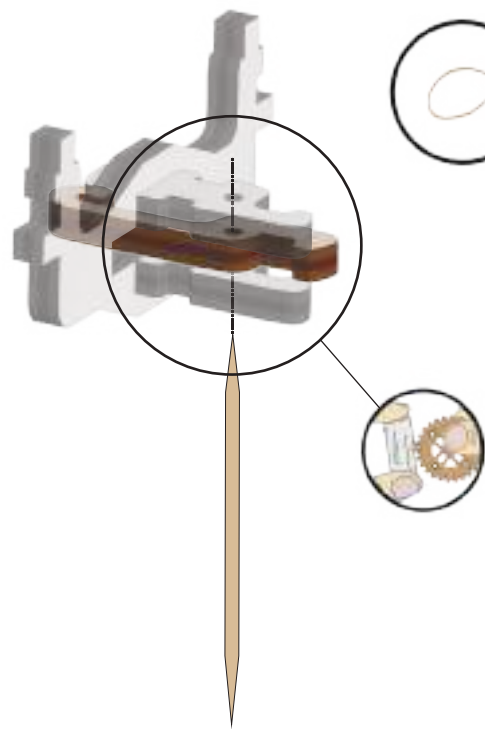
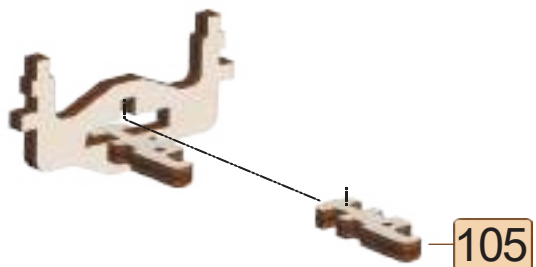
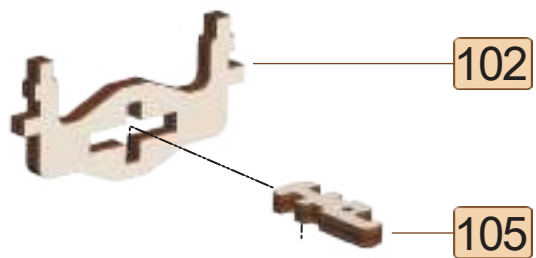
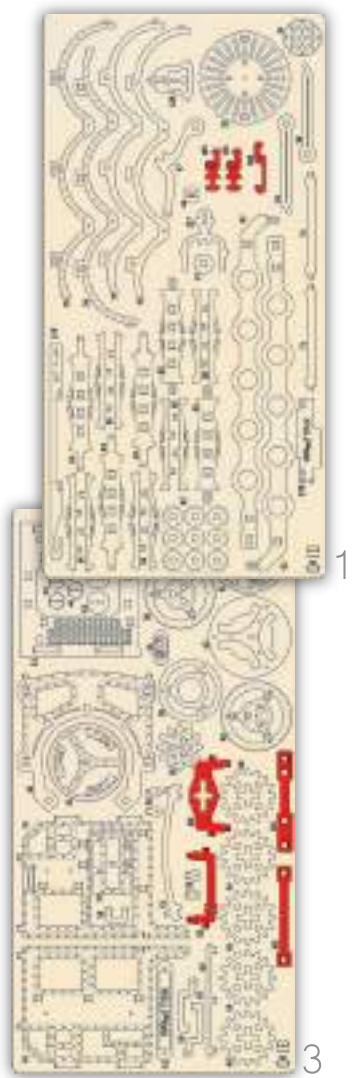

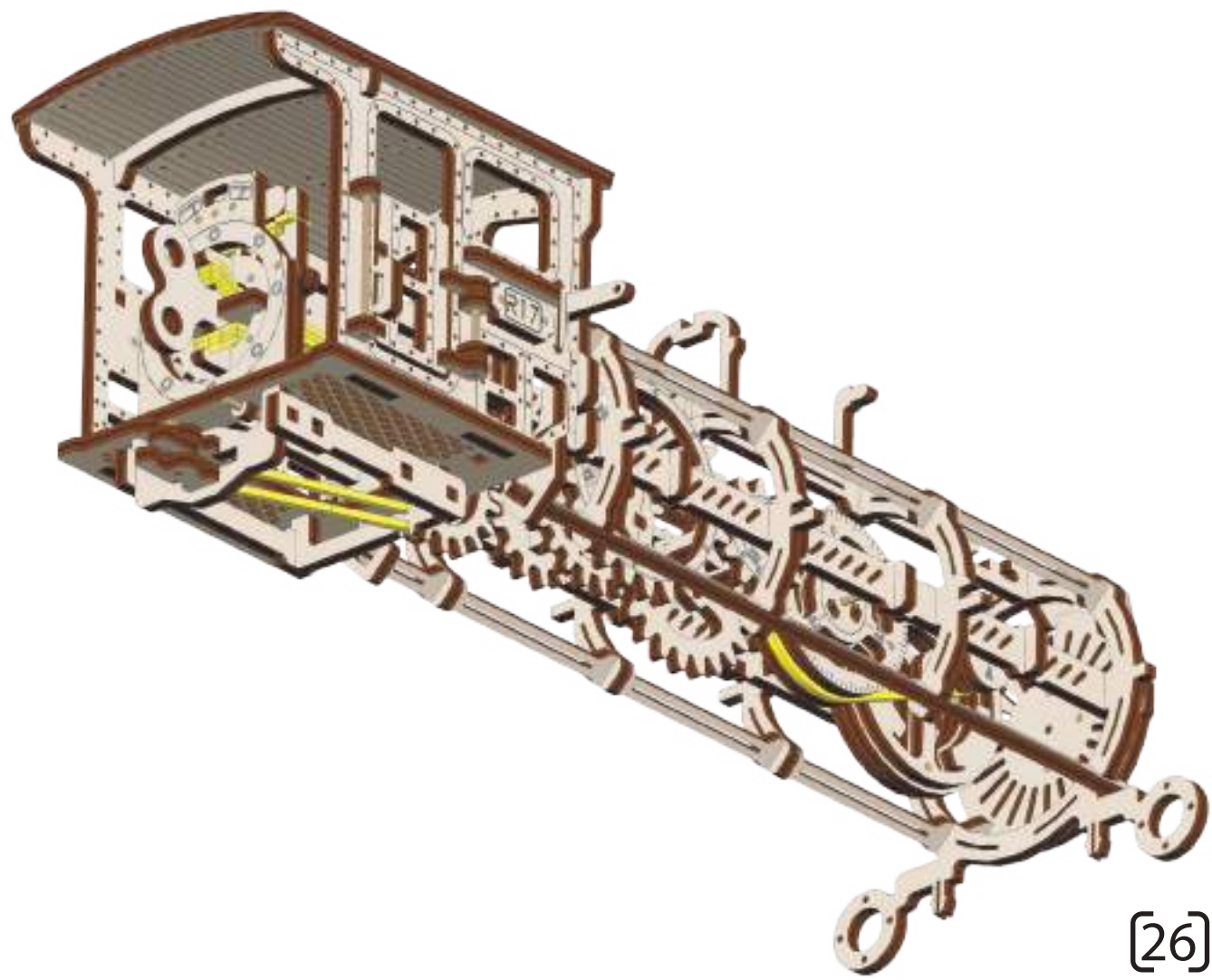
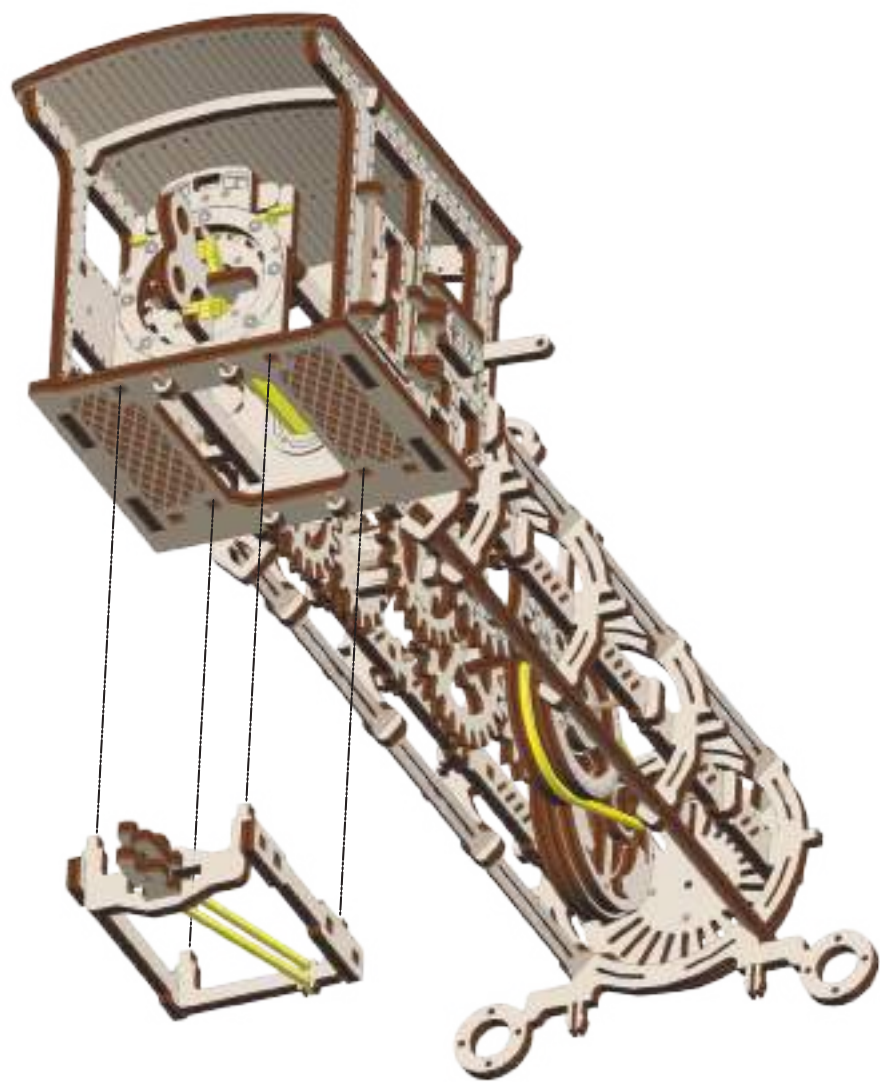

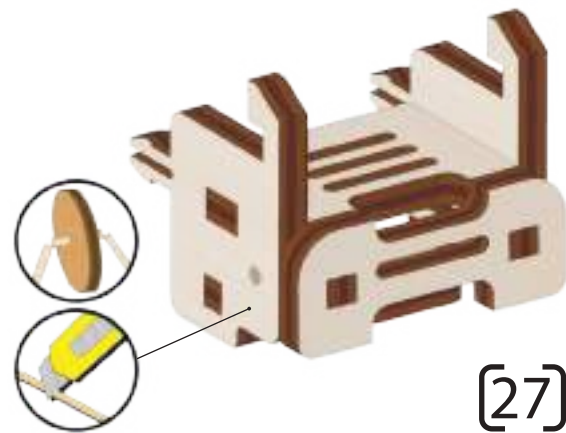
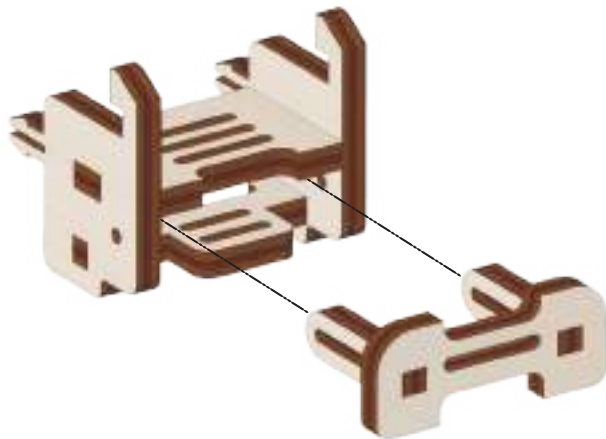
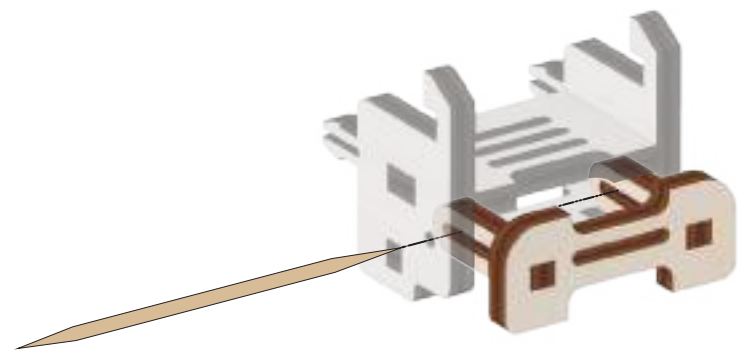
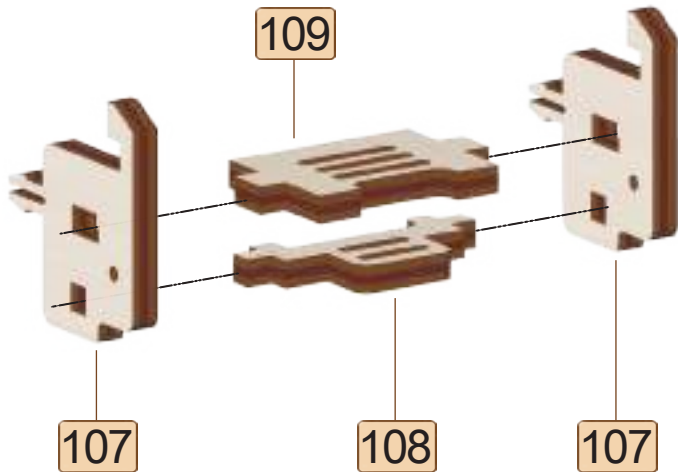
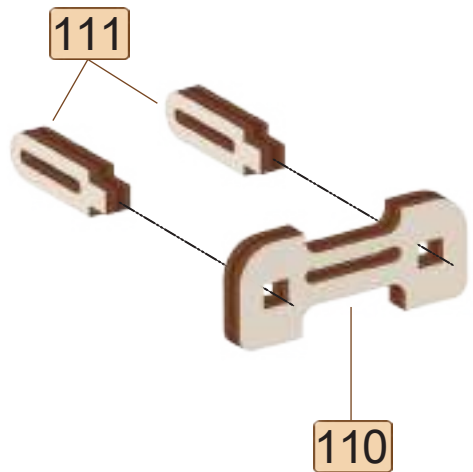

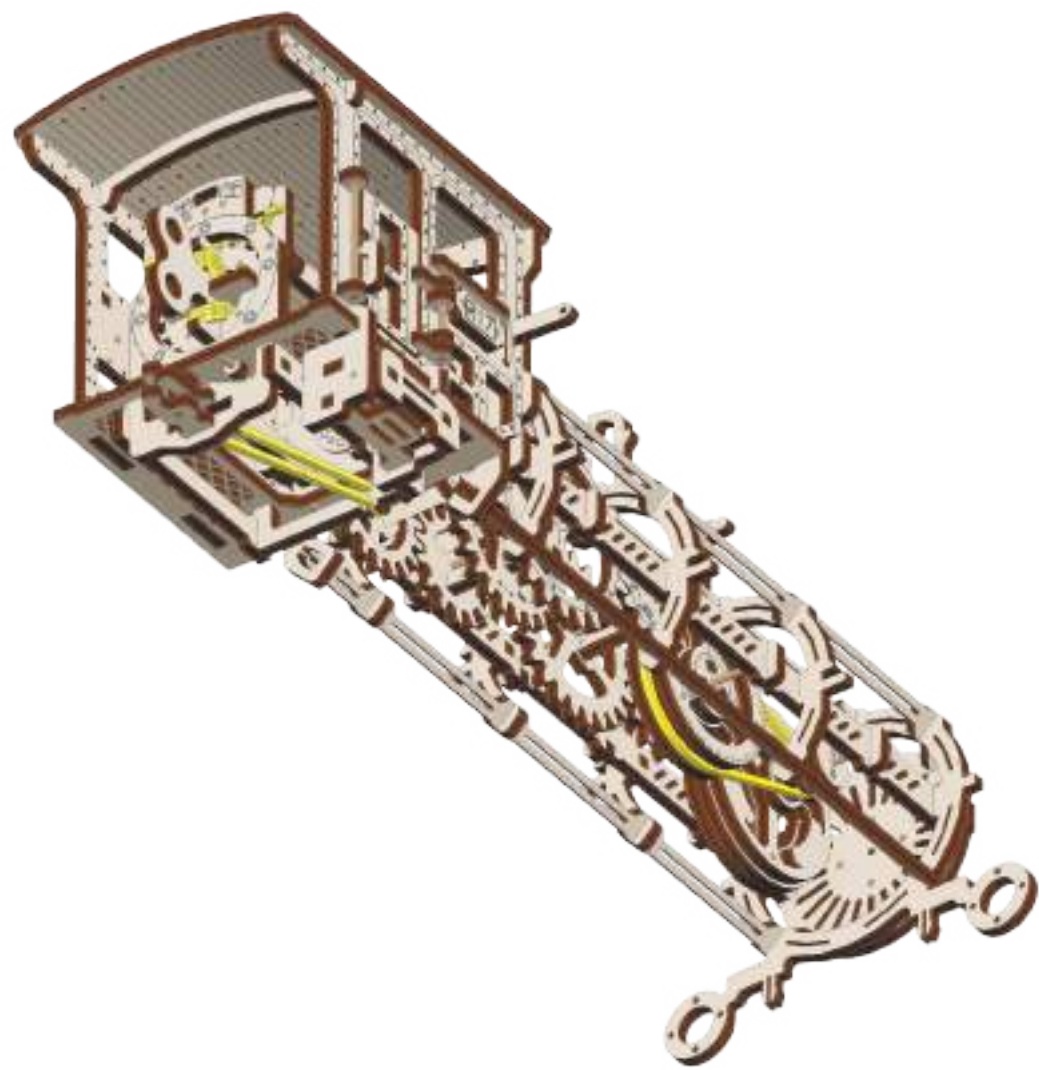
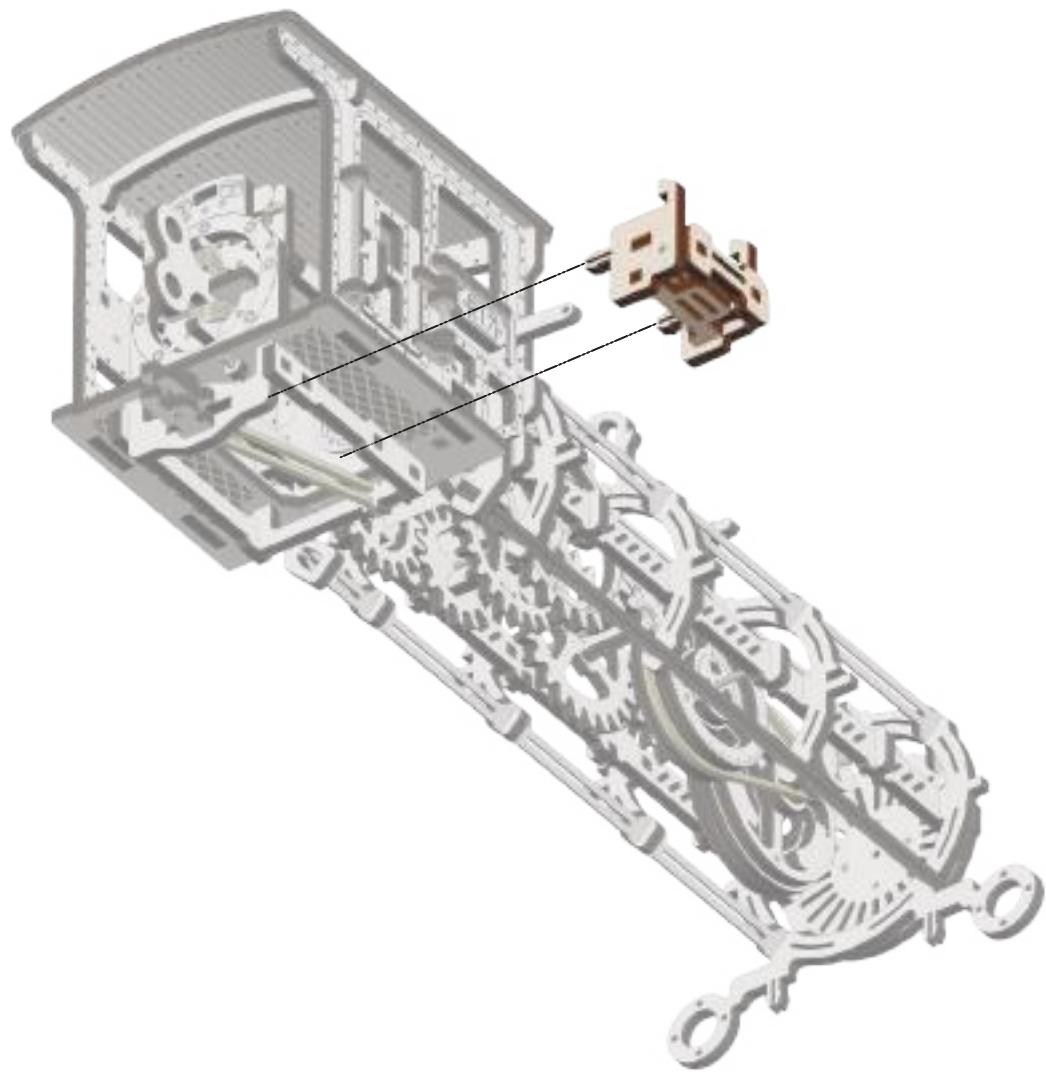



2

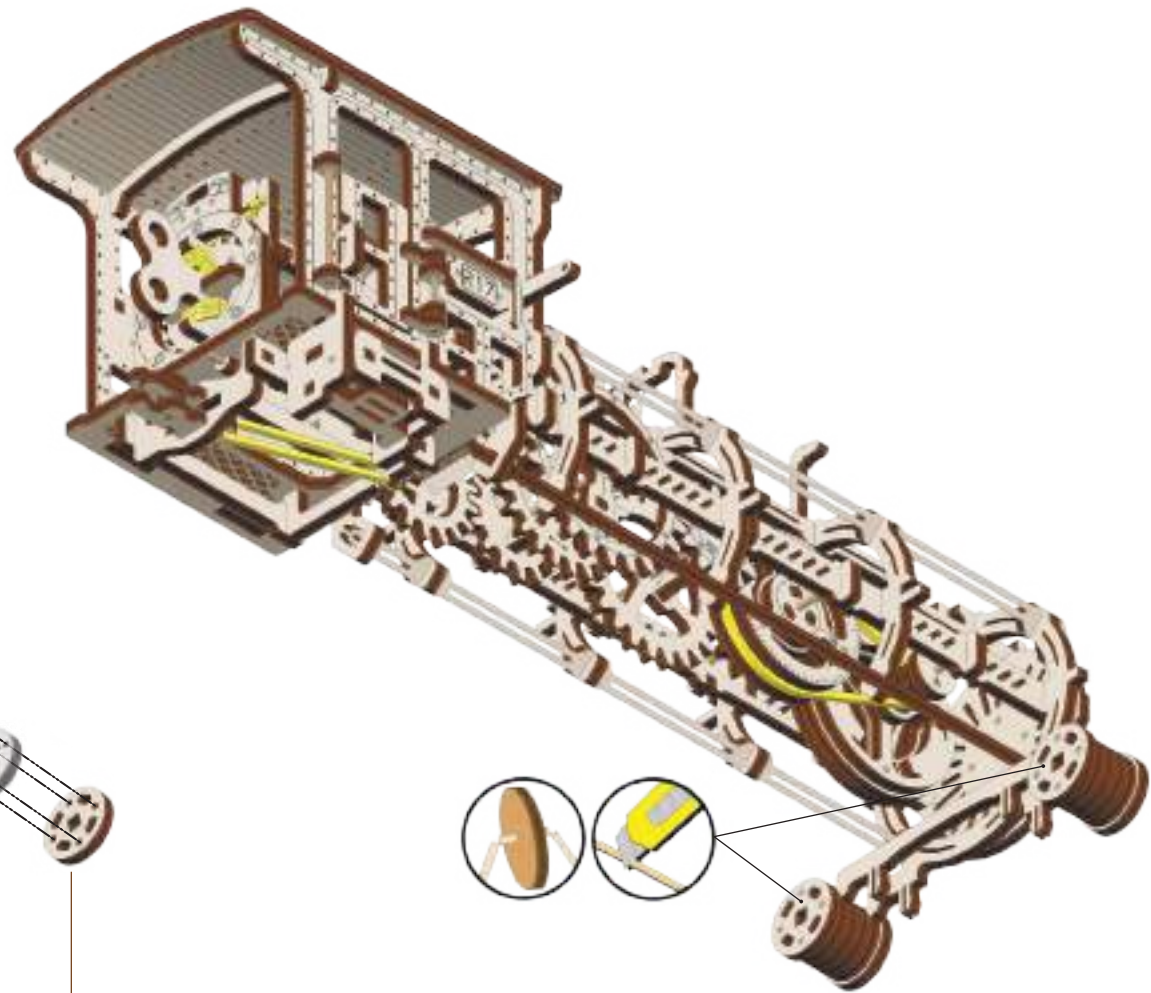
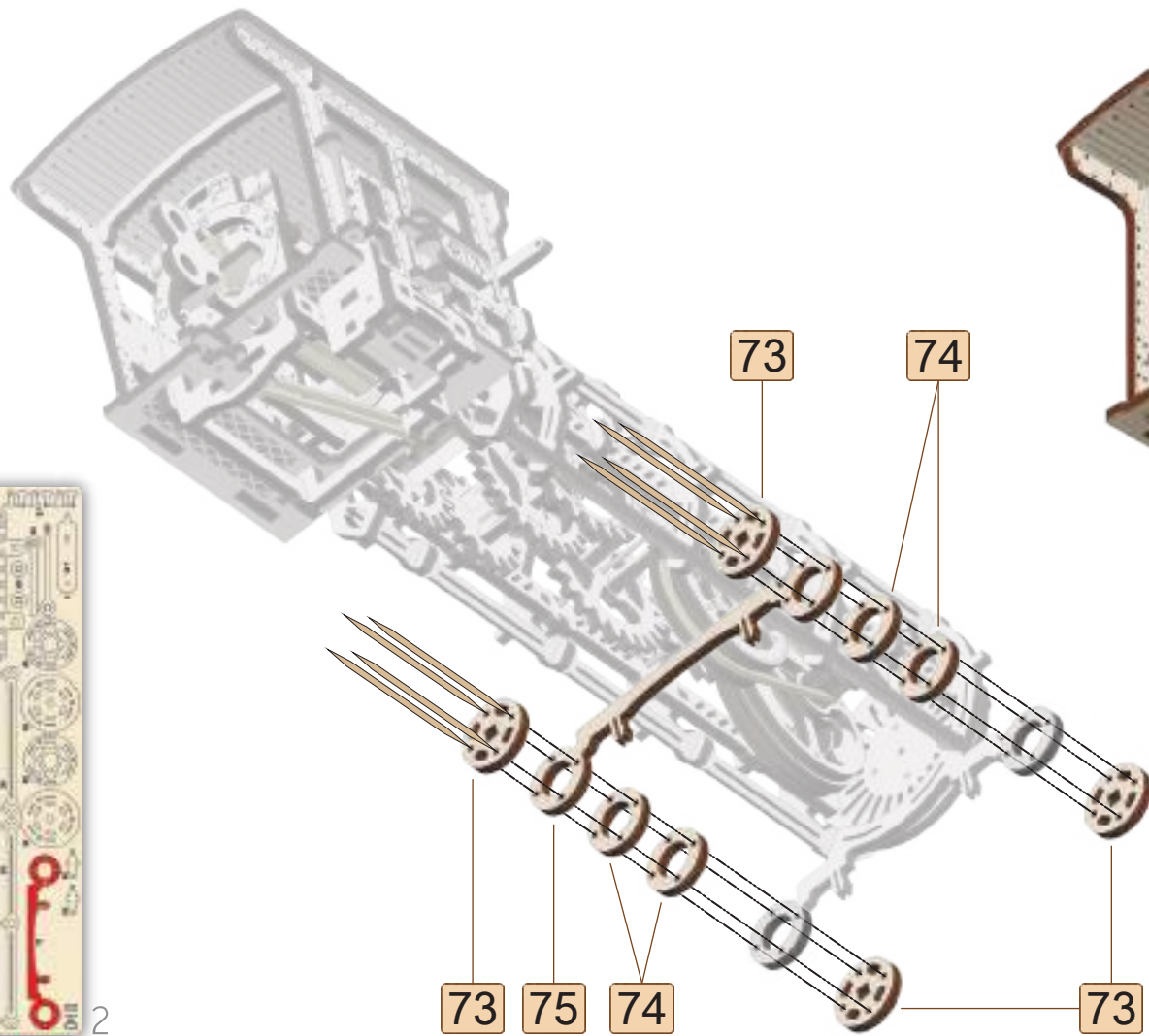

[29]



77

76

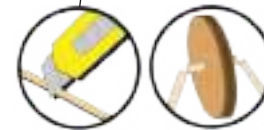
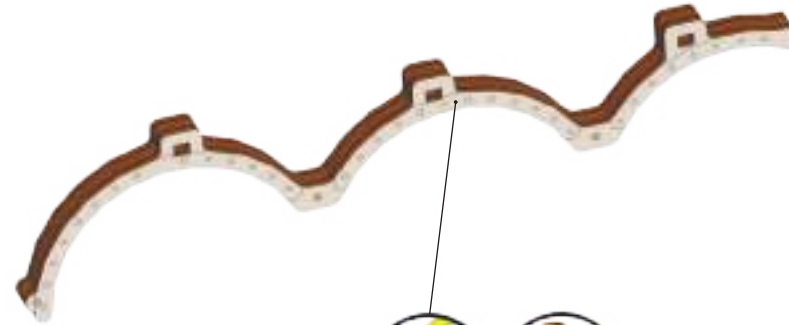
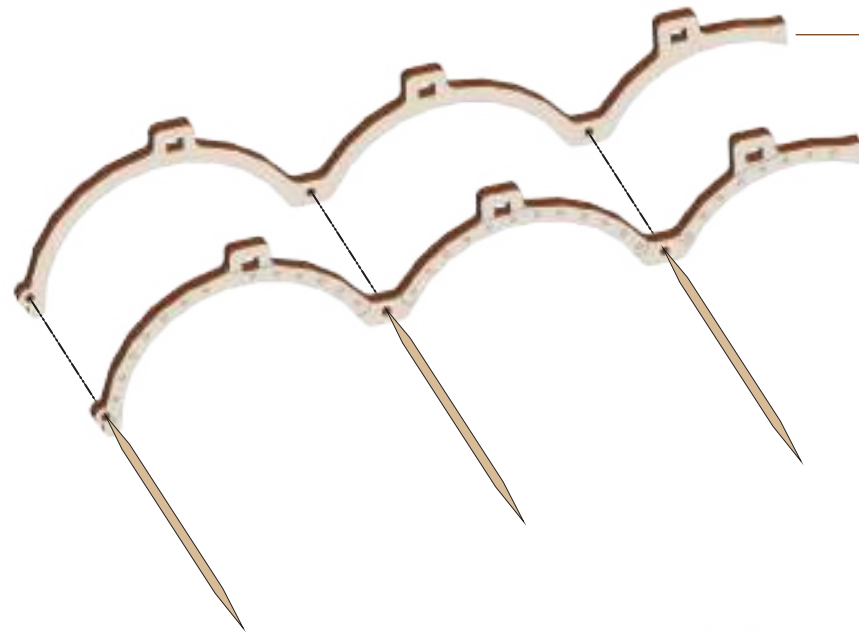
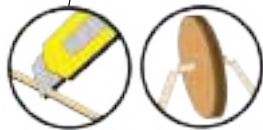
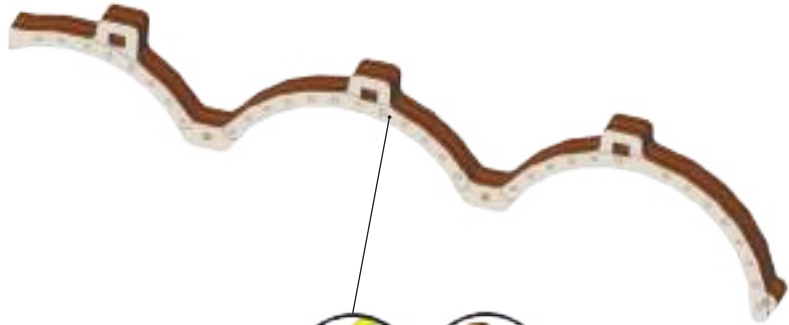
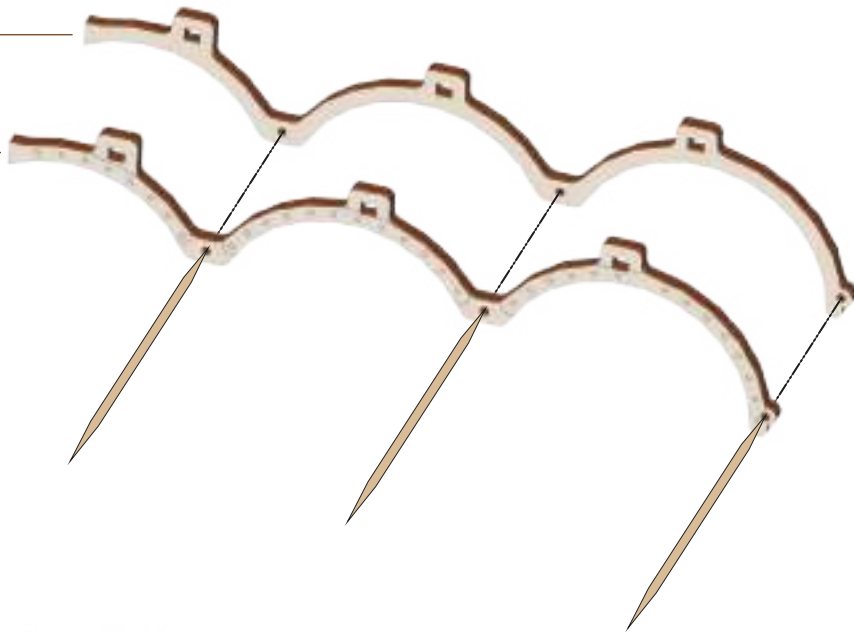

77

78

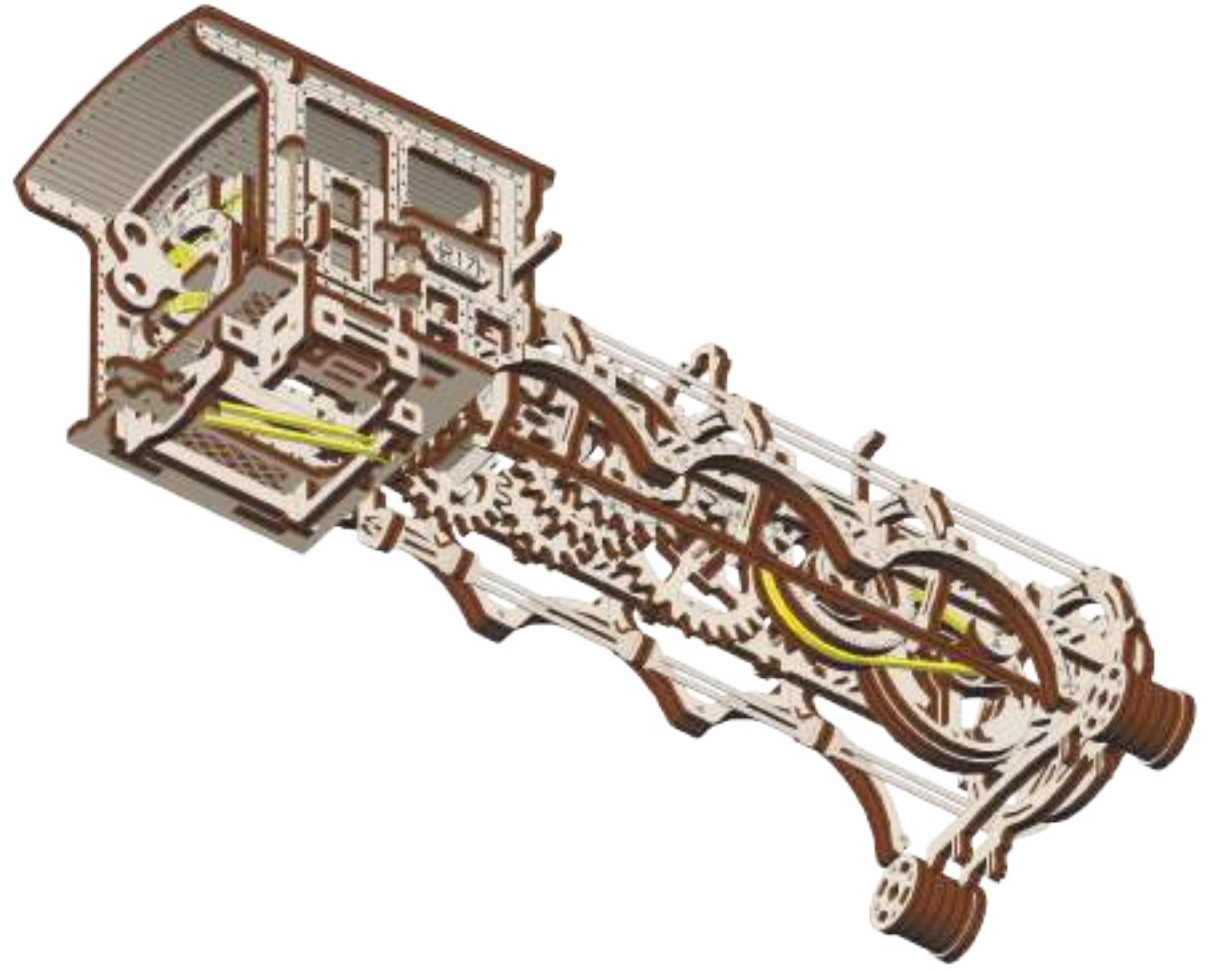
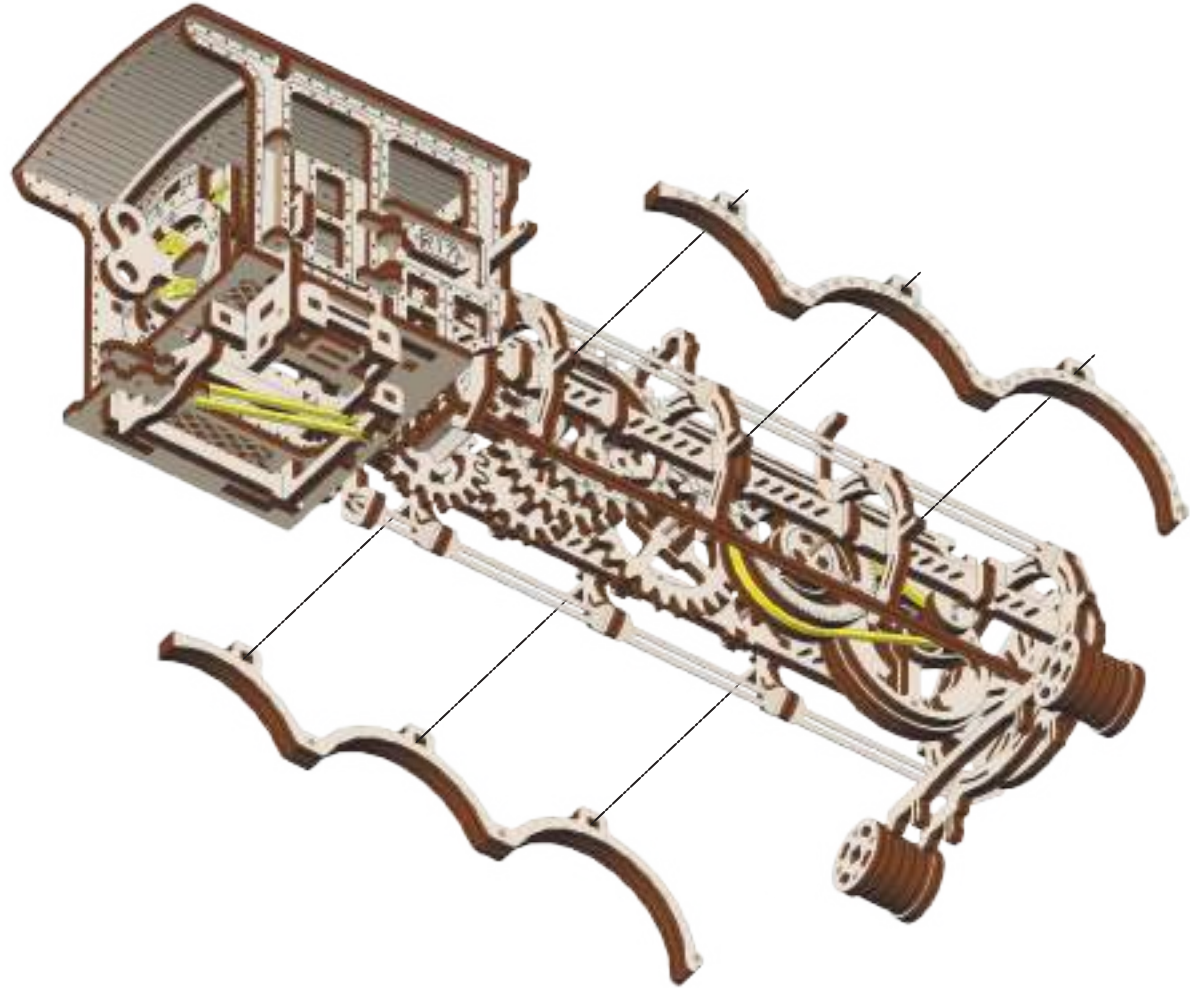



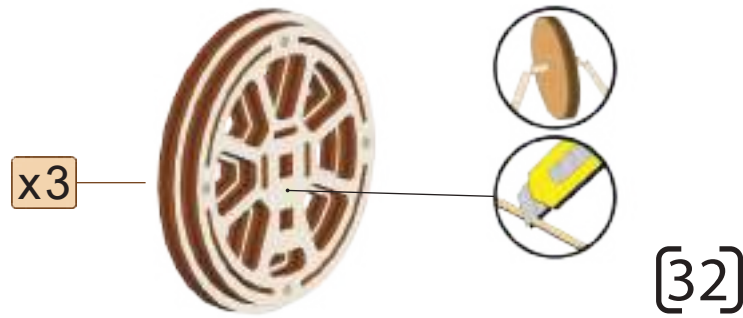
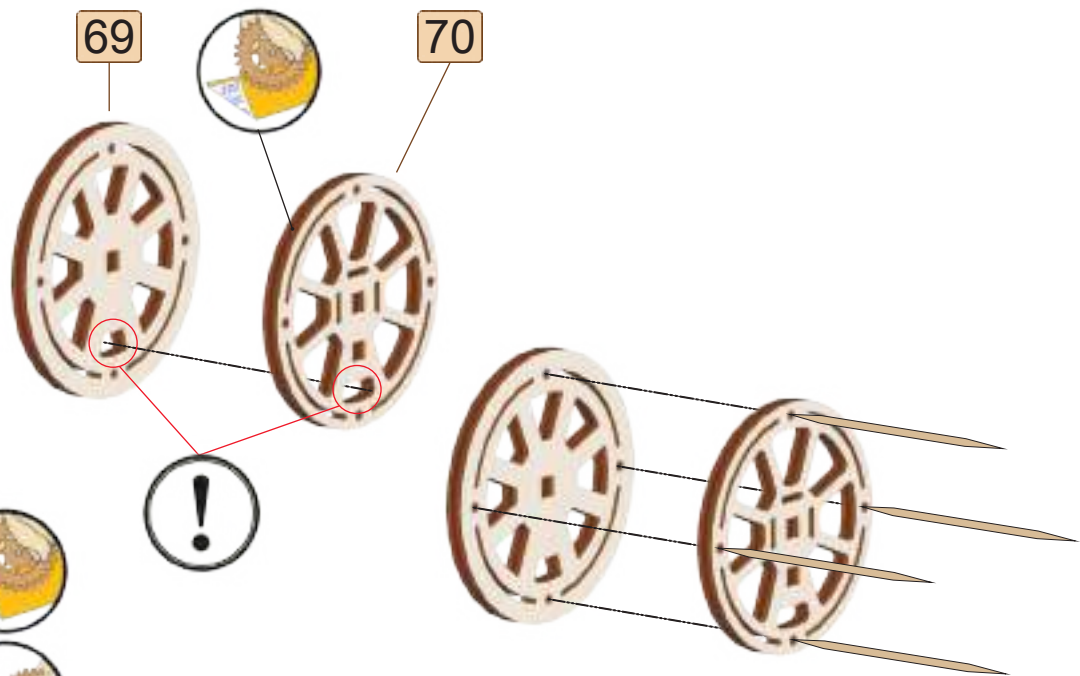
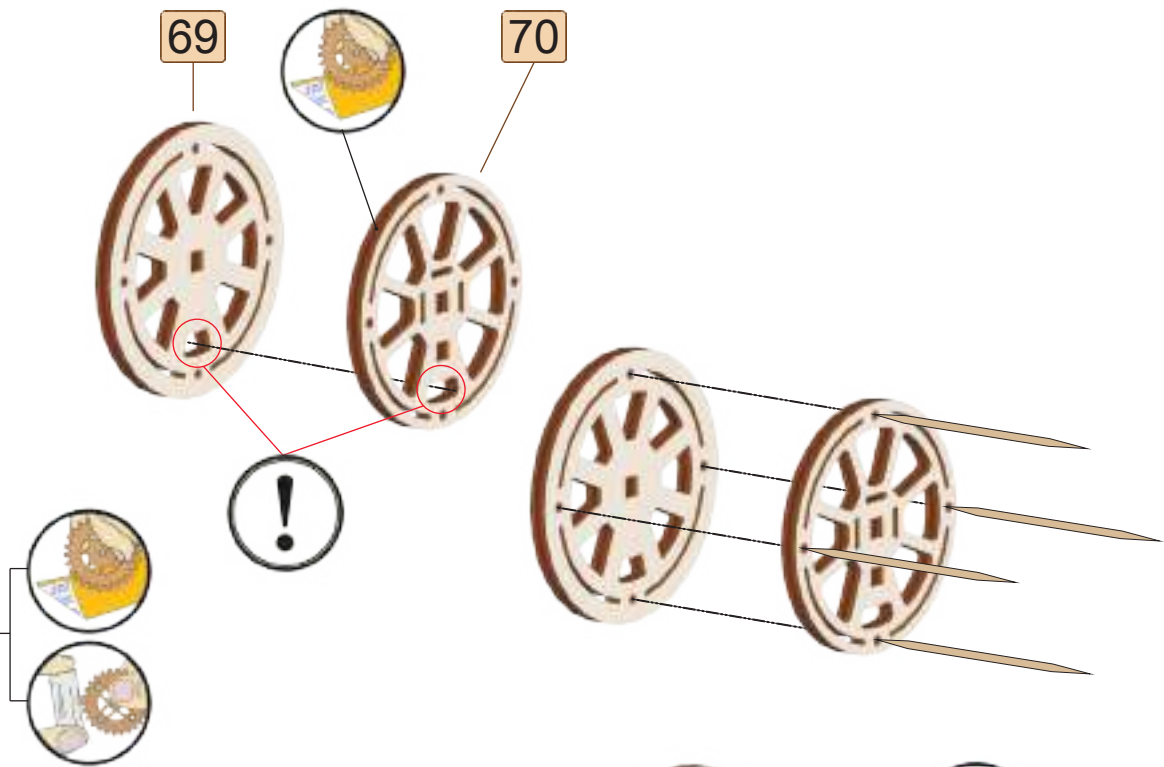
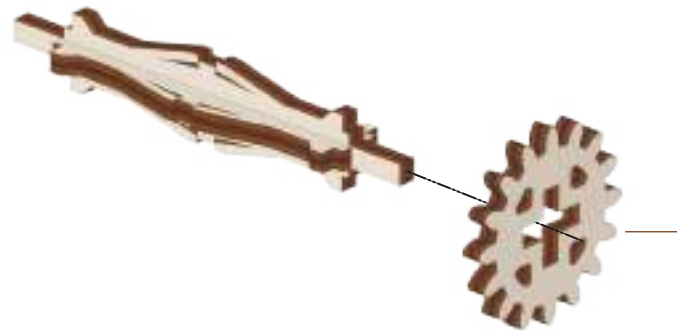
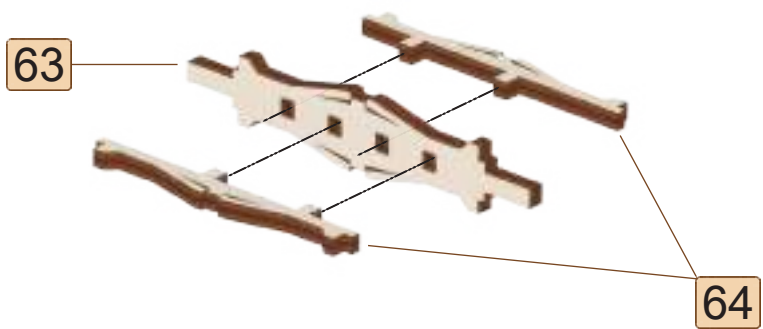
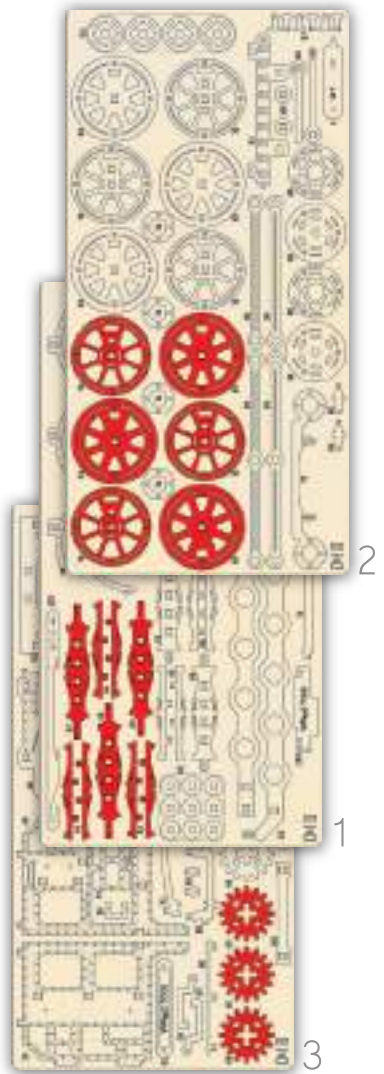

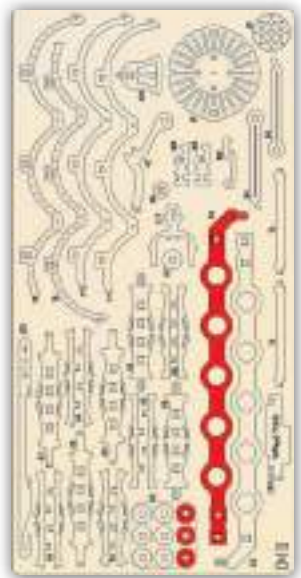

1

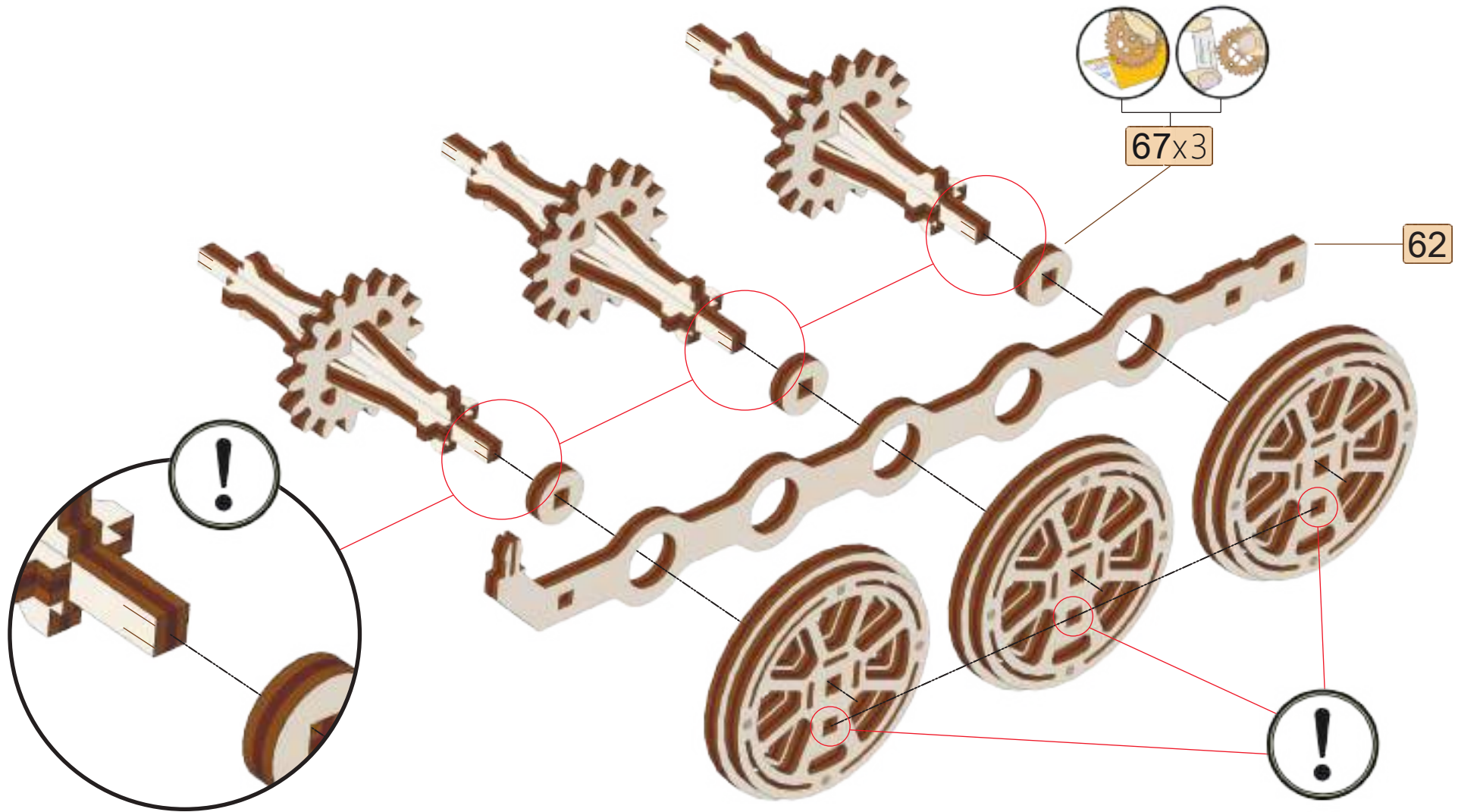



2

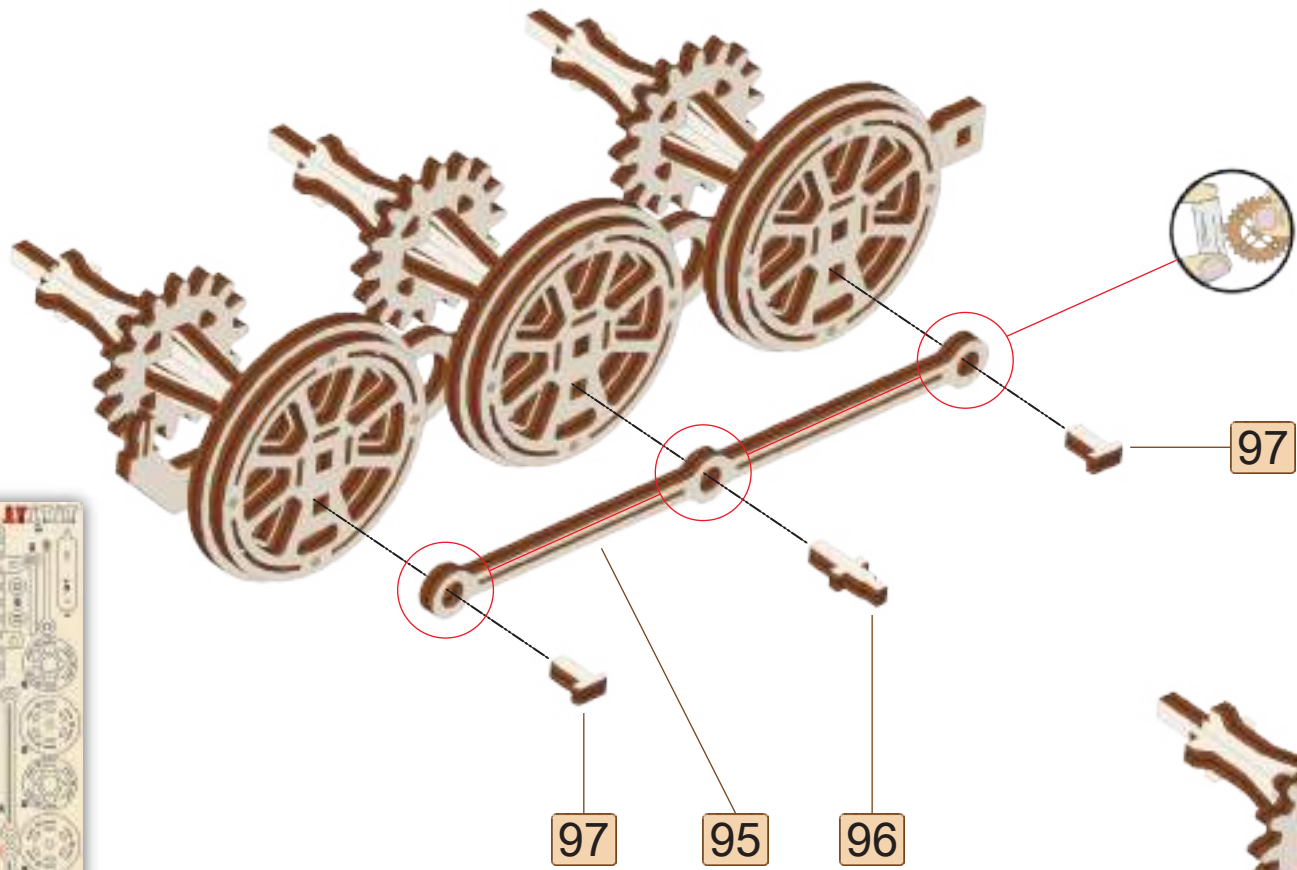

97

97

95

96



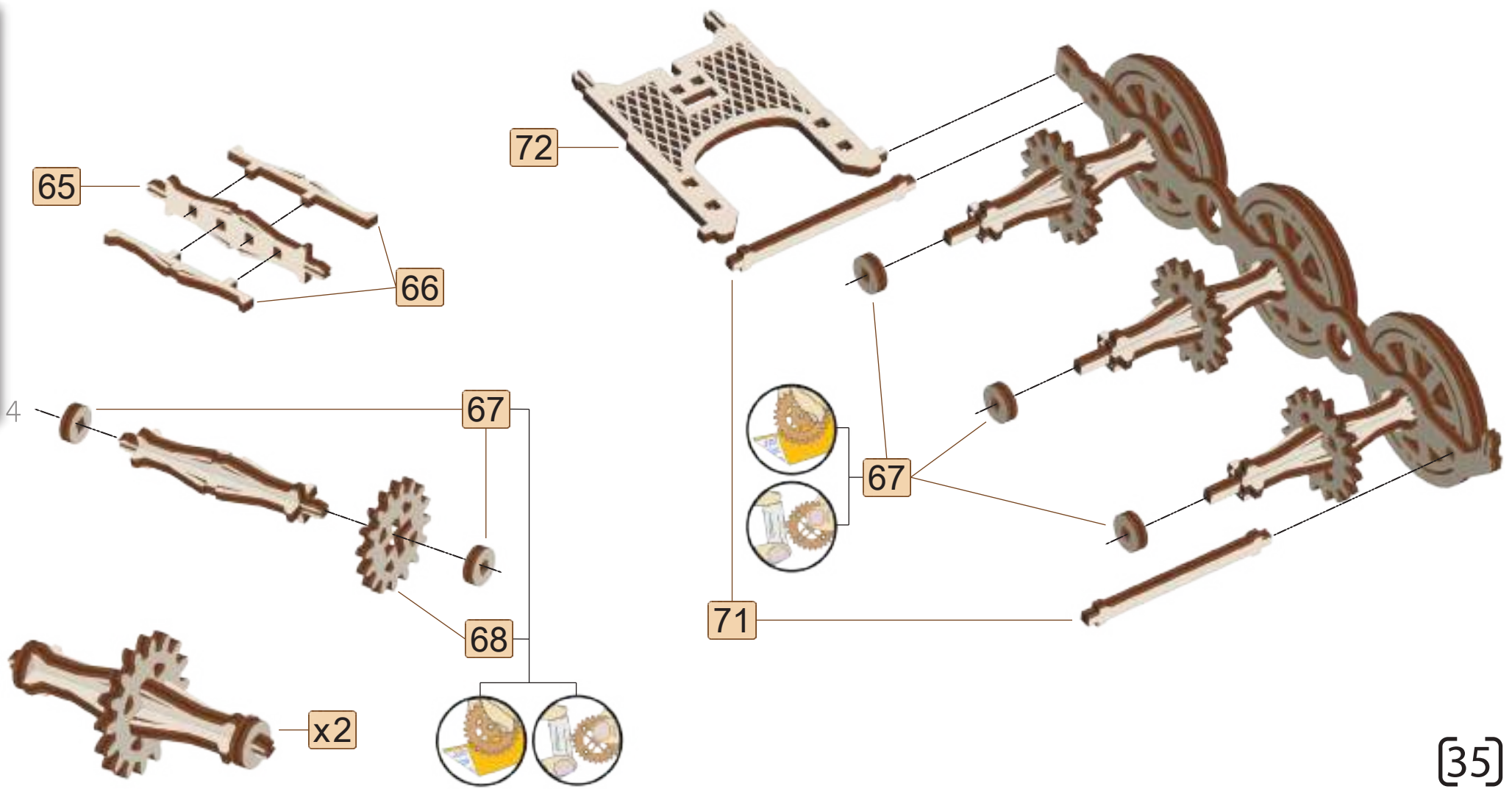

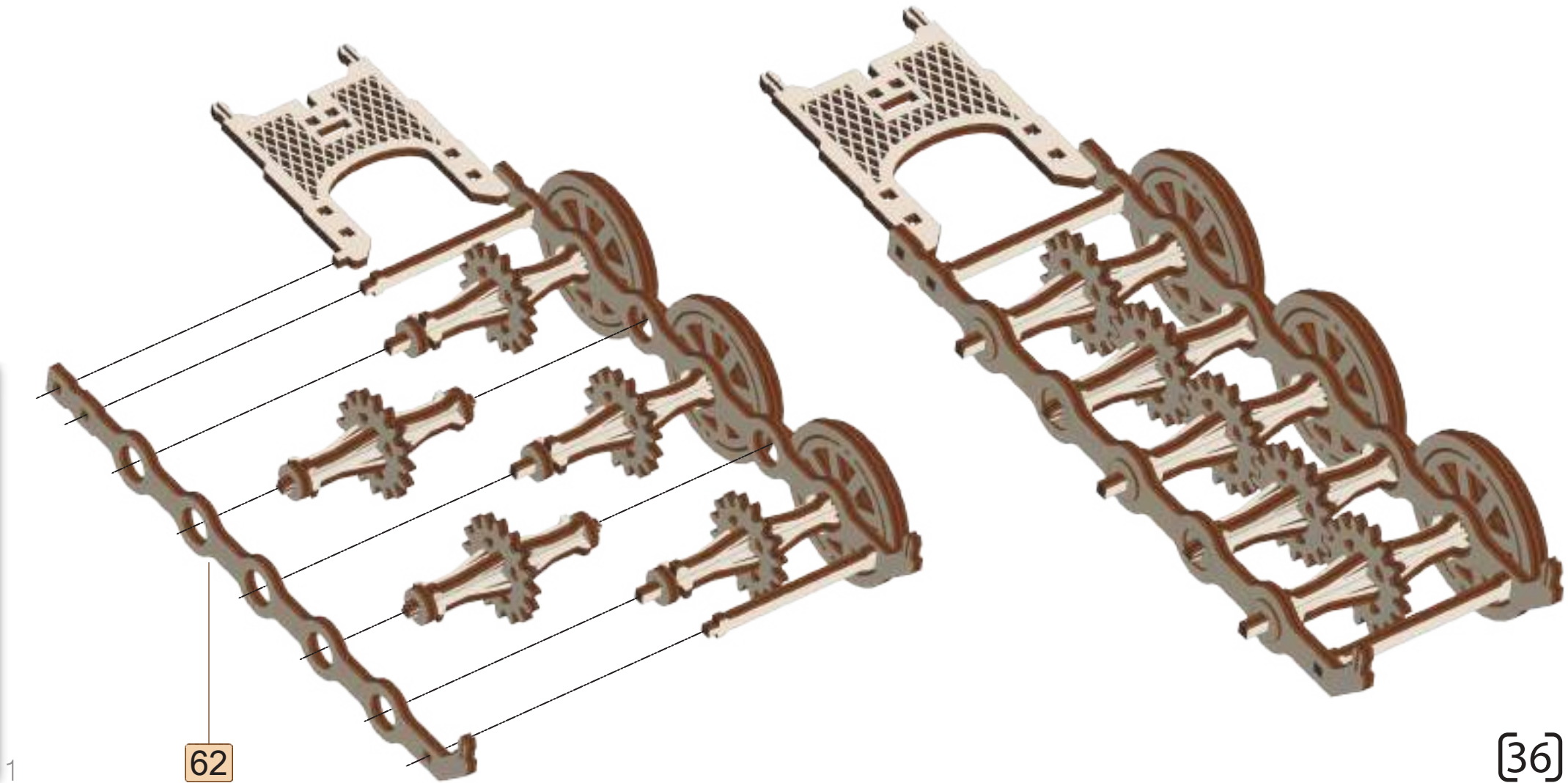
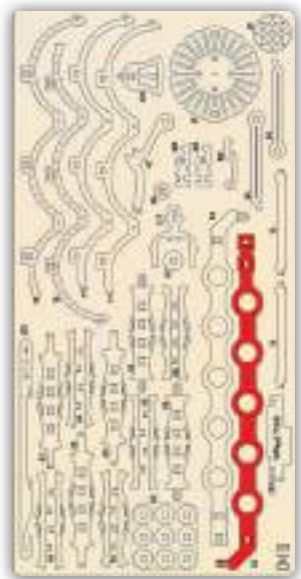

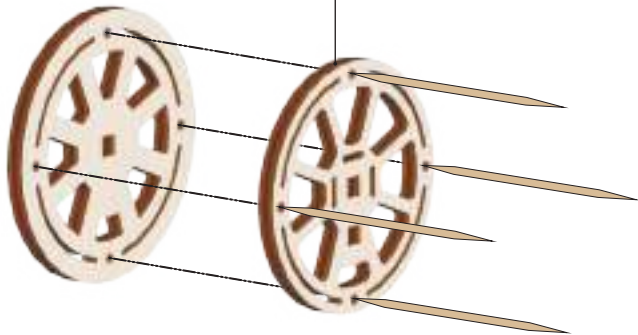
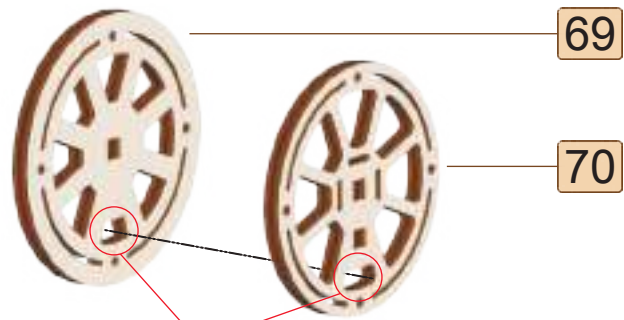

x3

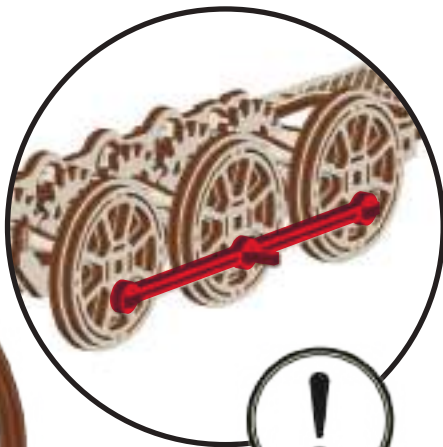
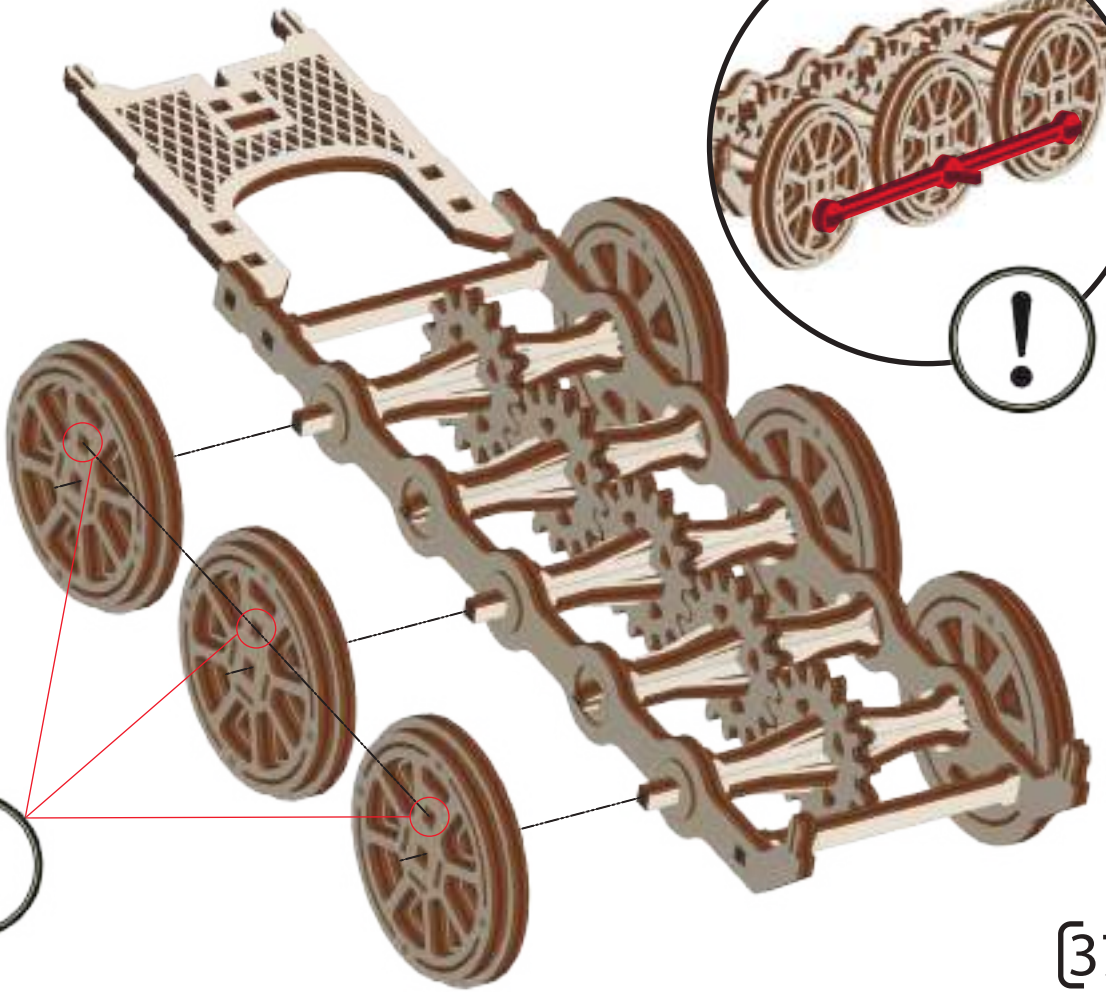



2

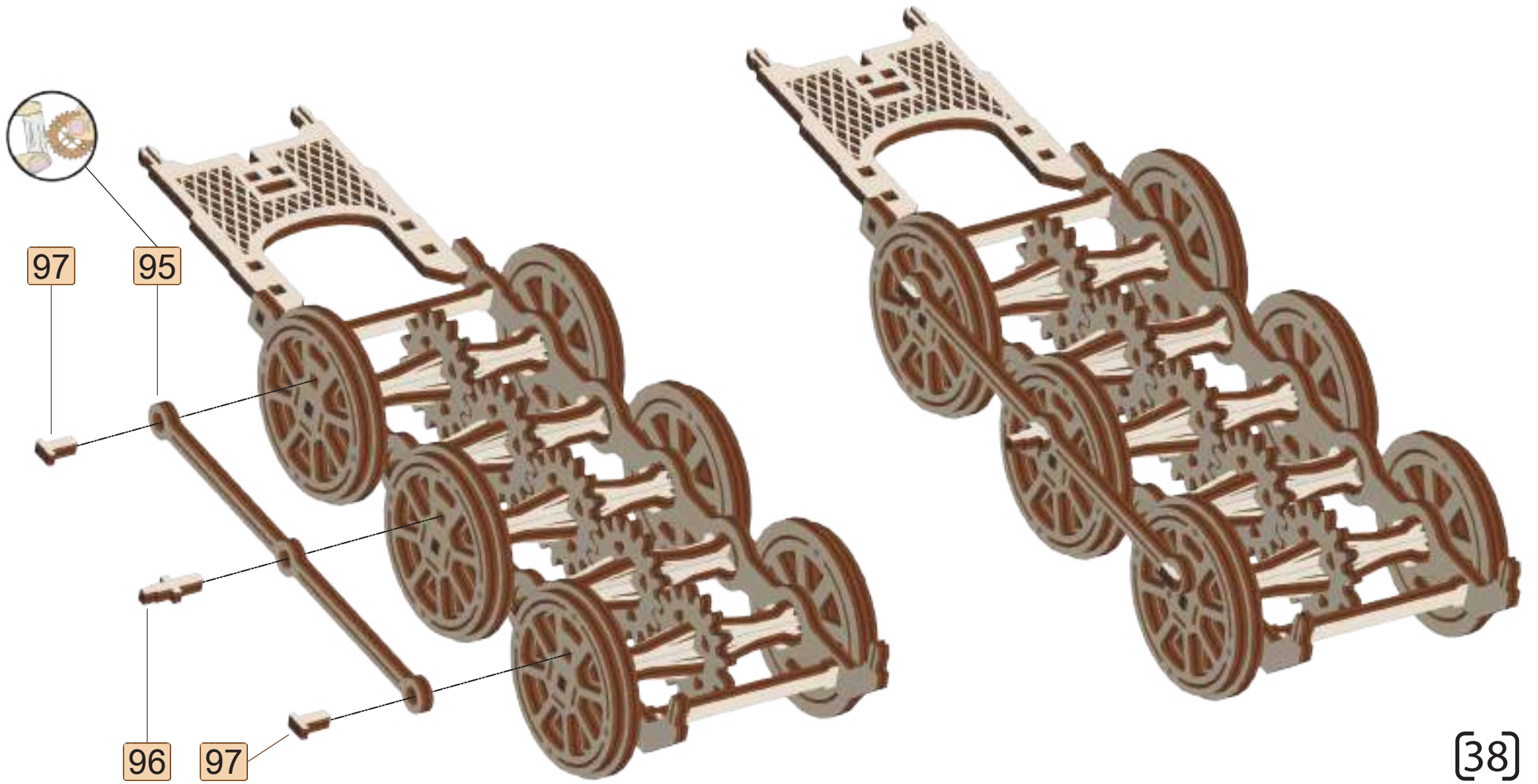

79

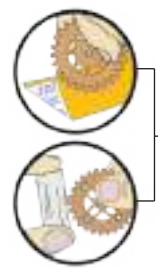
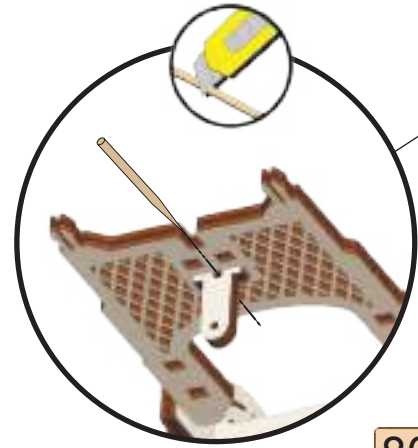
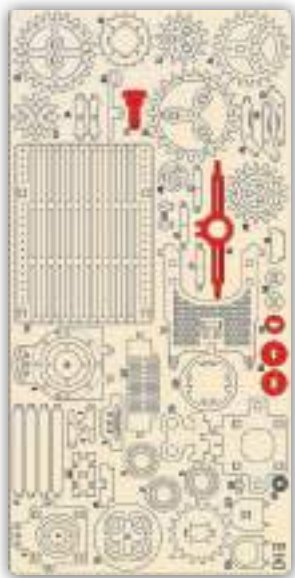

80

81

80

82

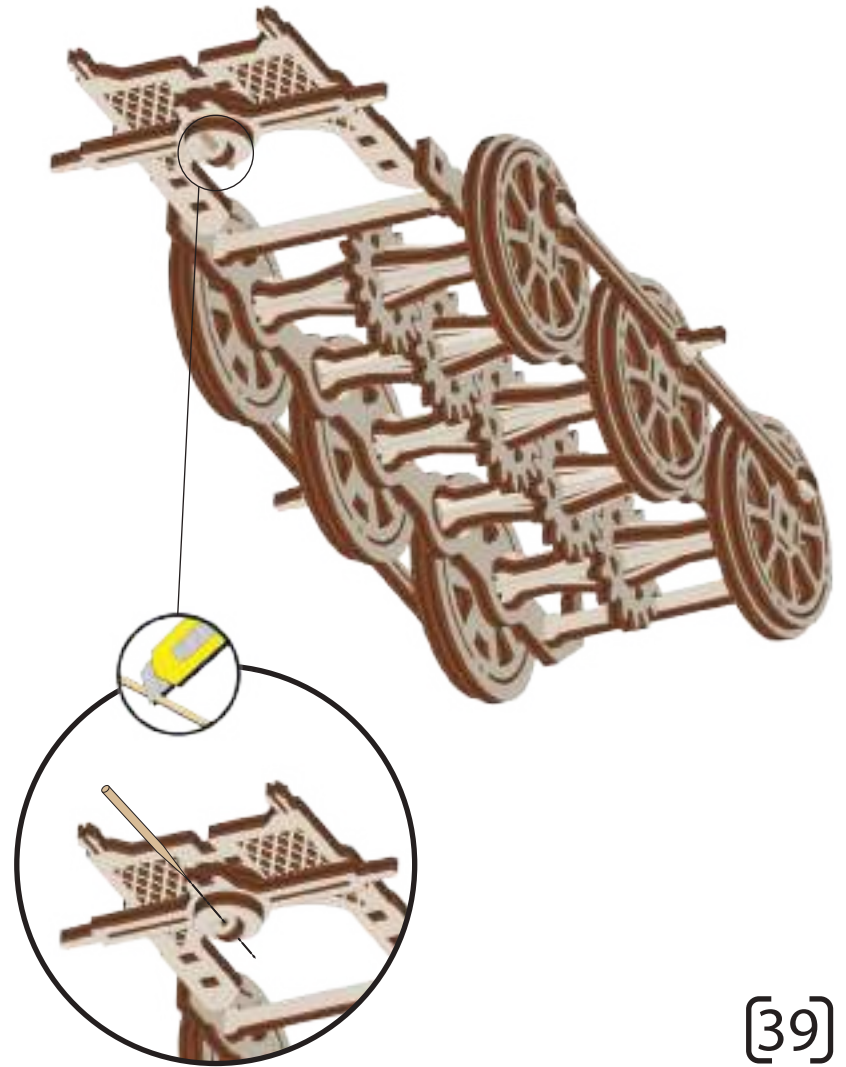
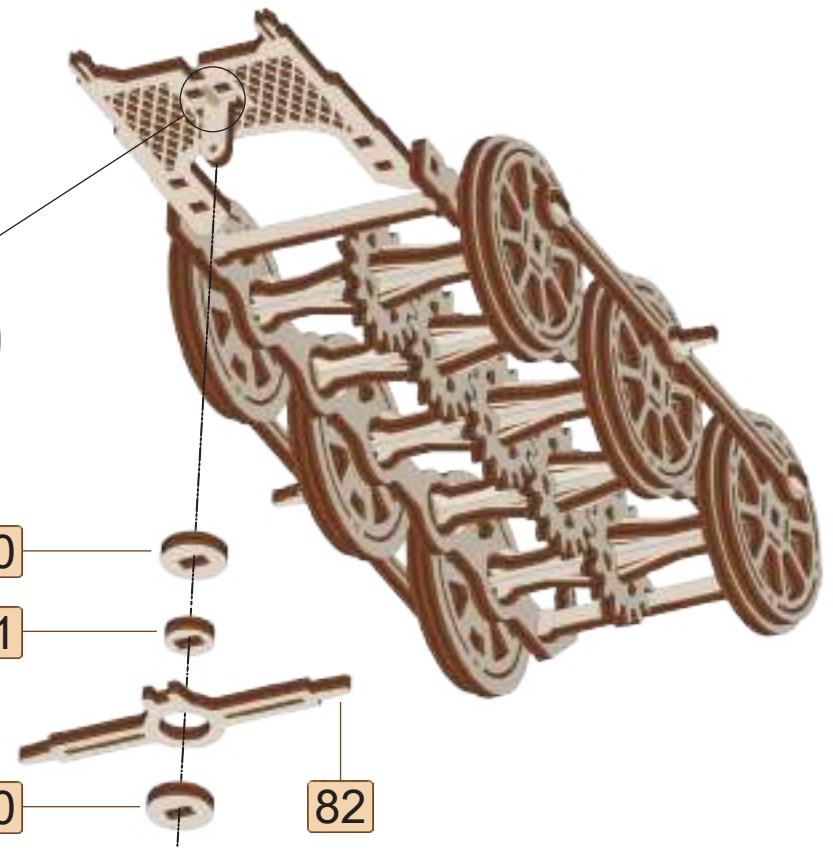



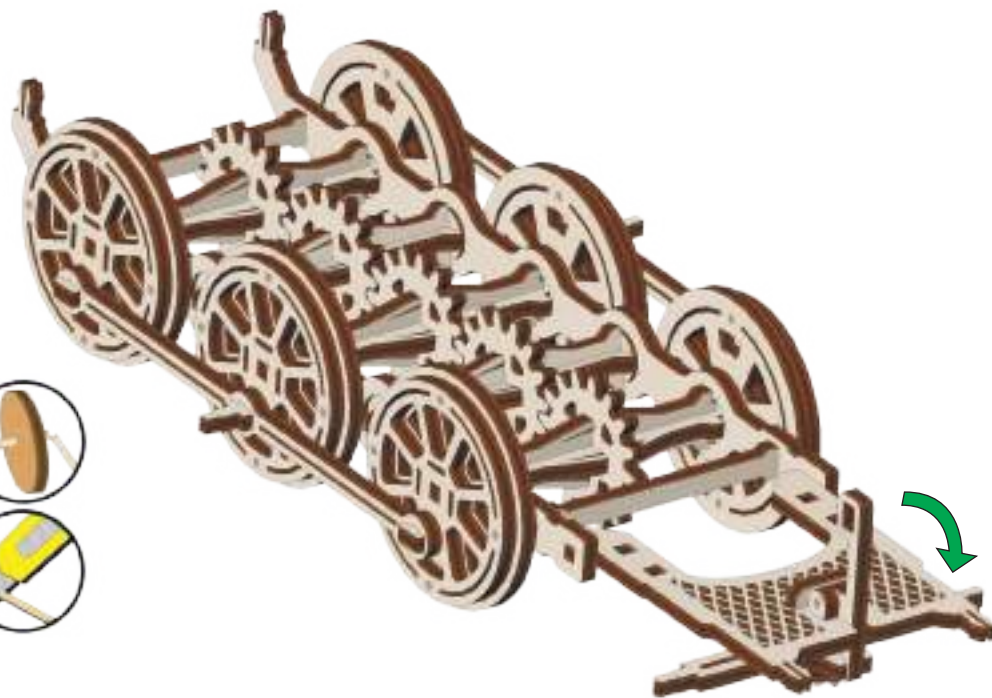
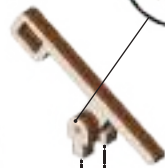
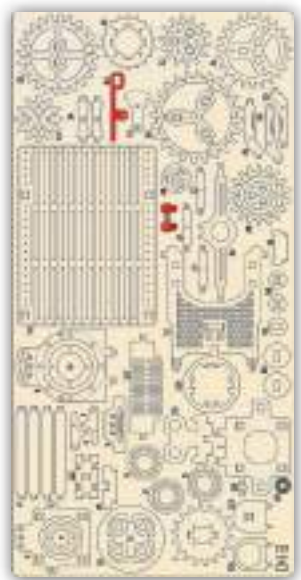
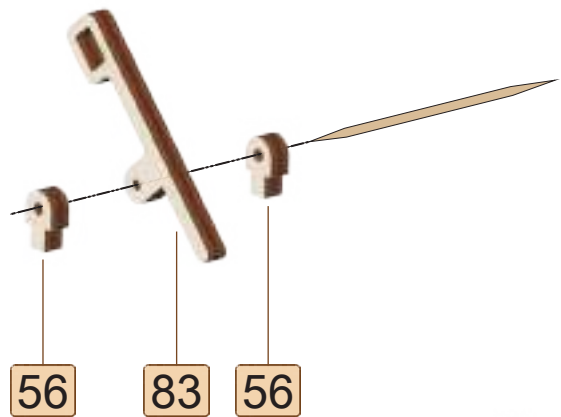

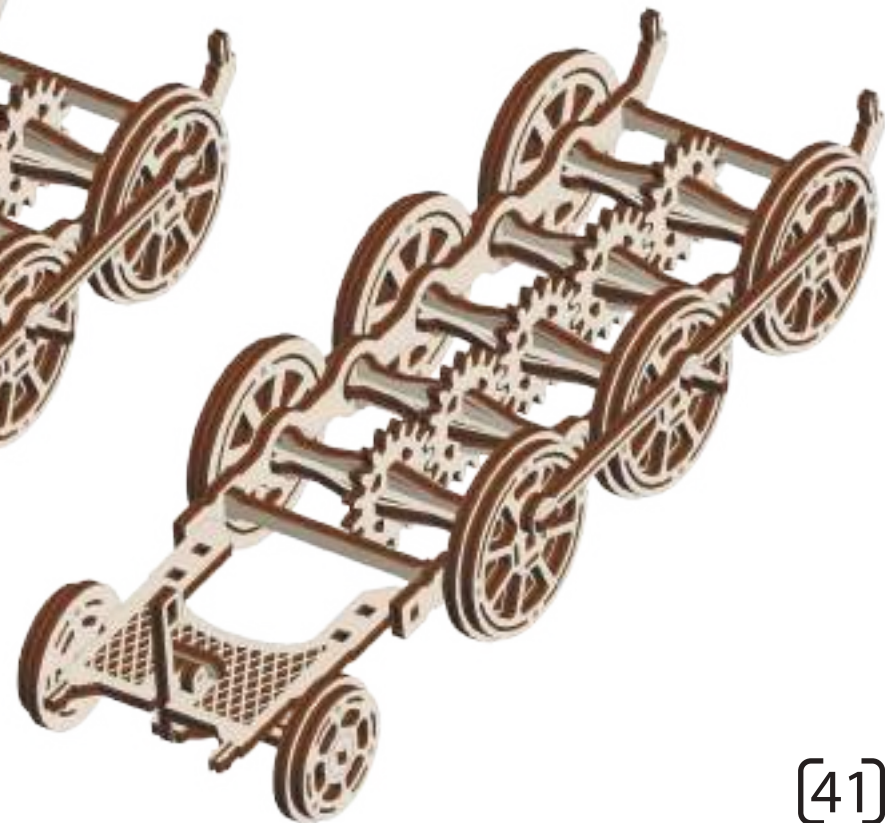
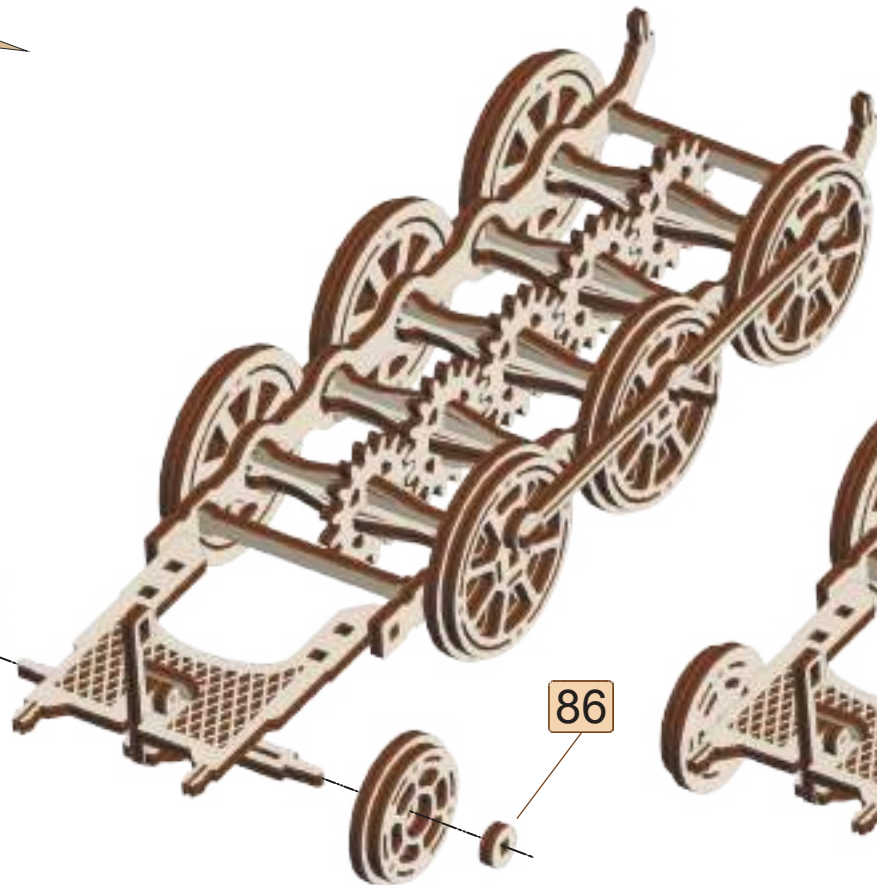
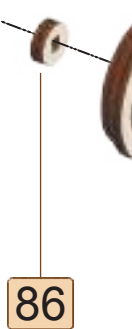
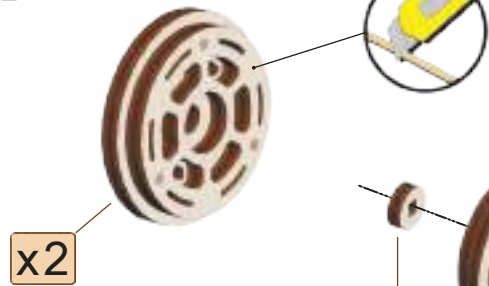
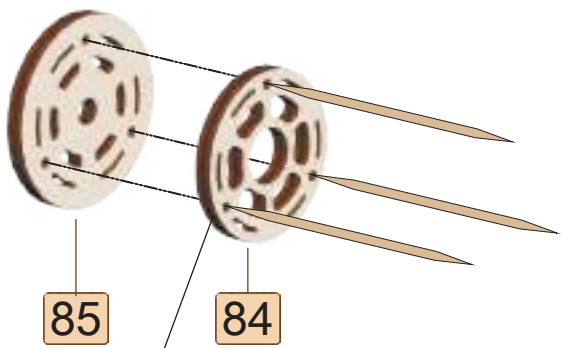
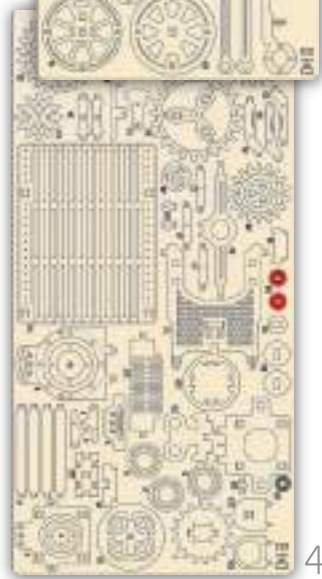

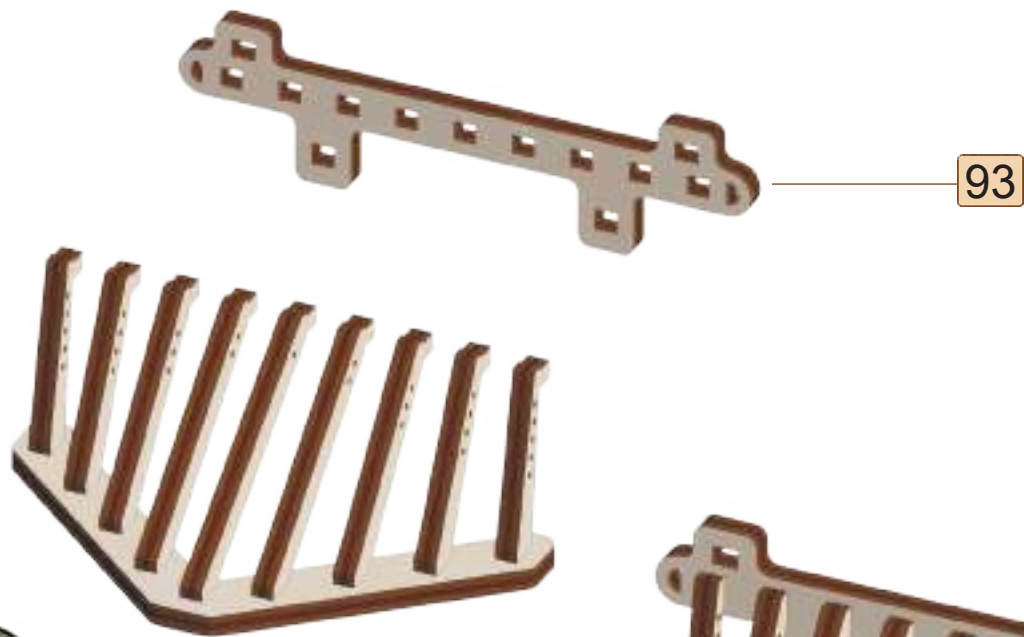
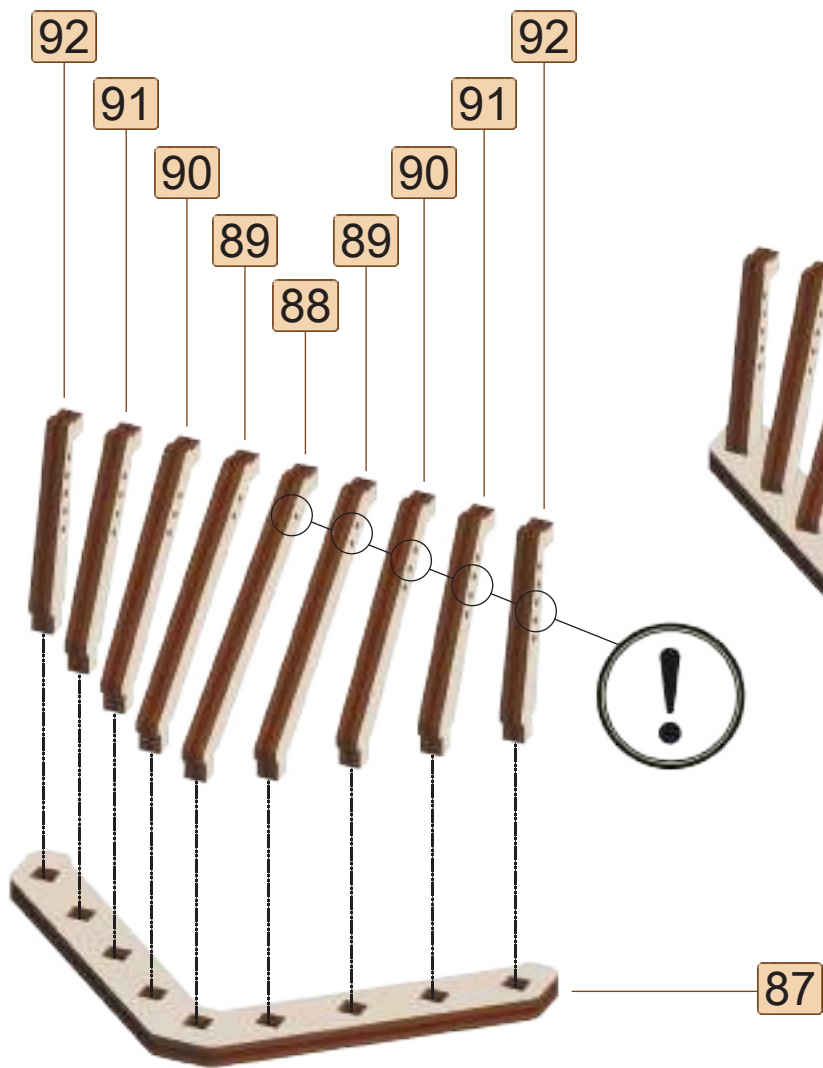



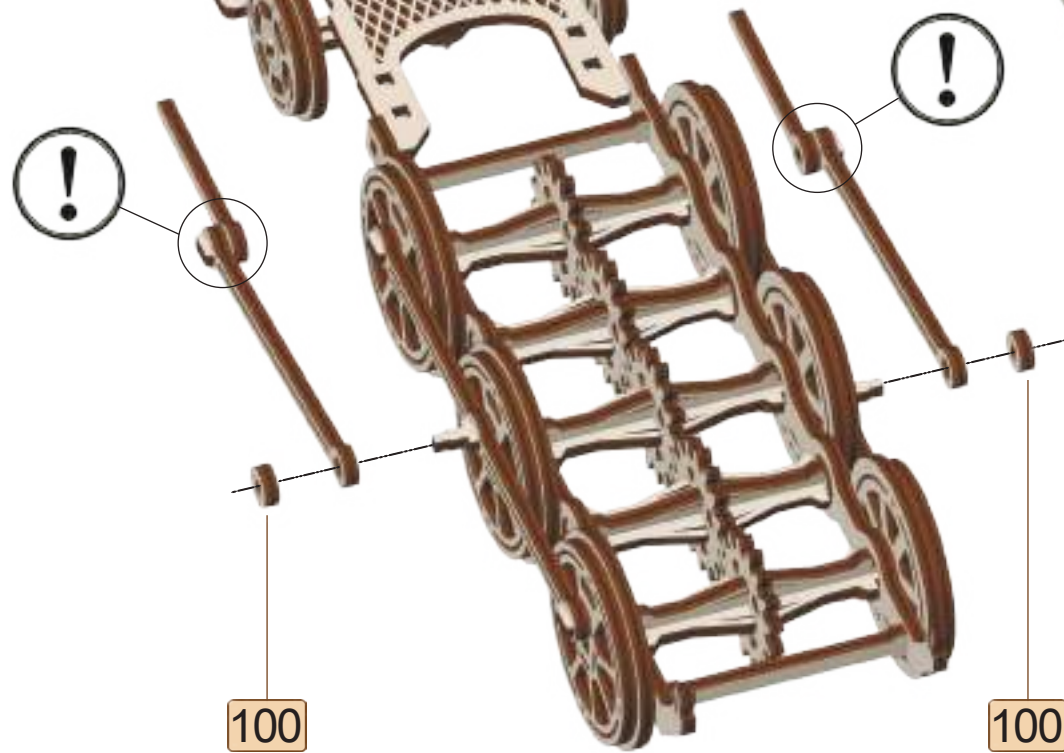
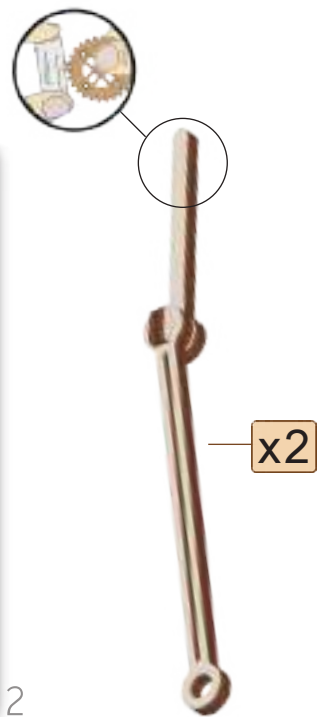

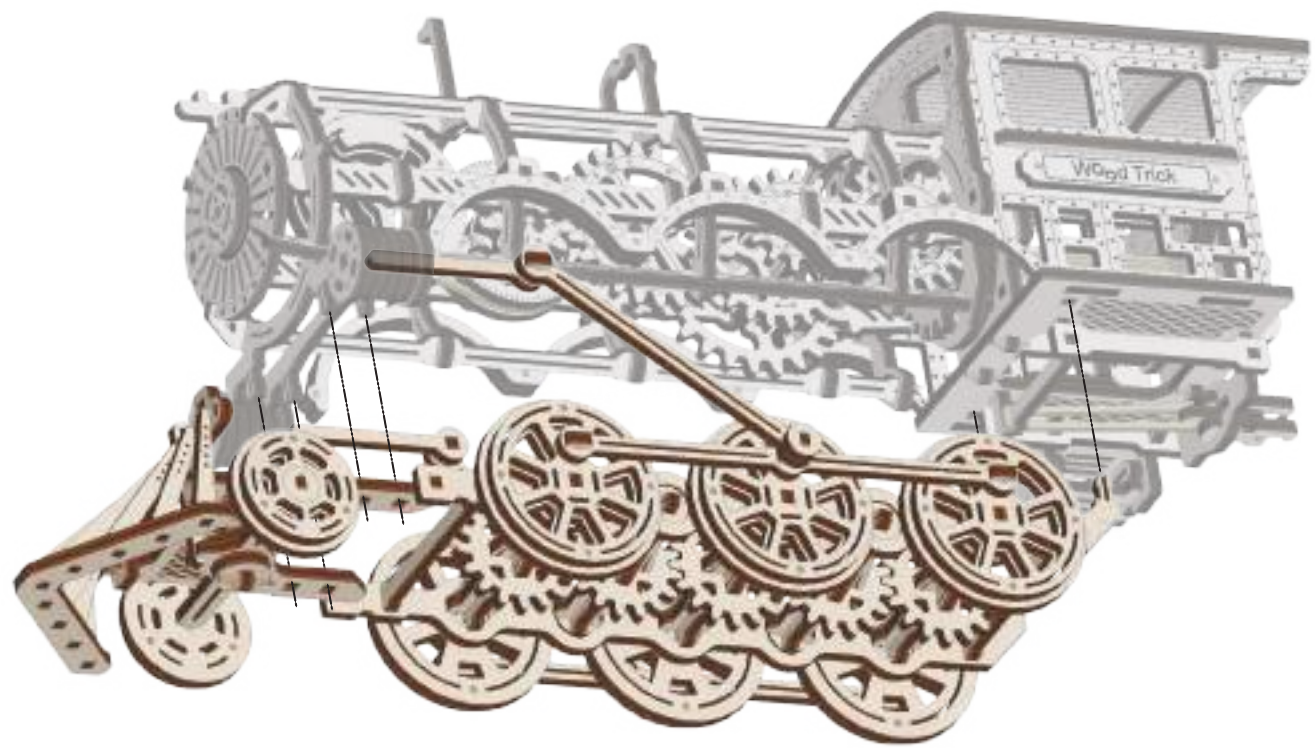
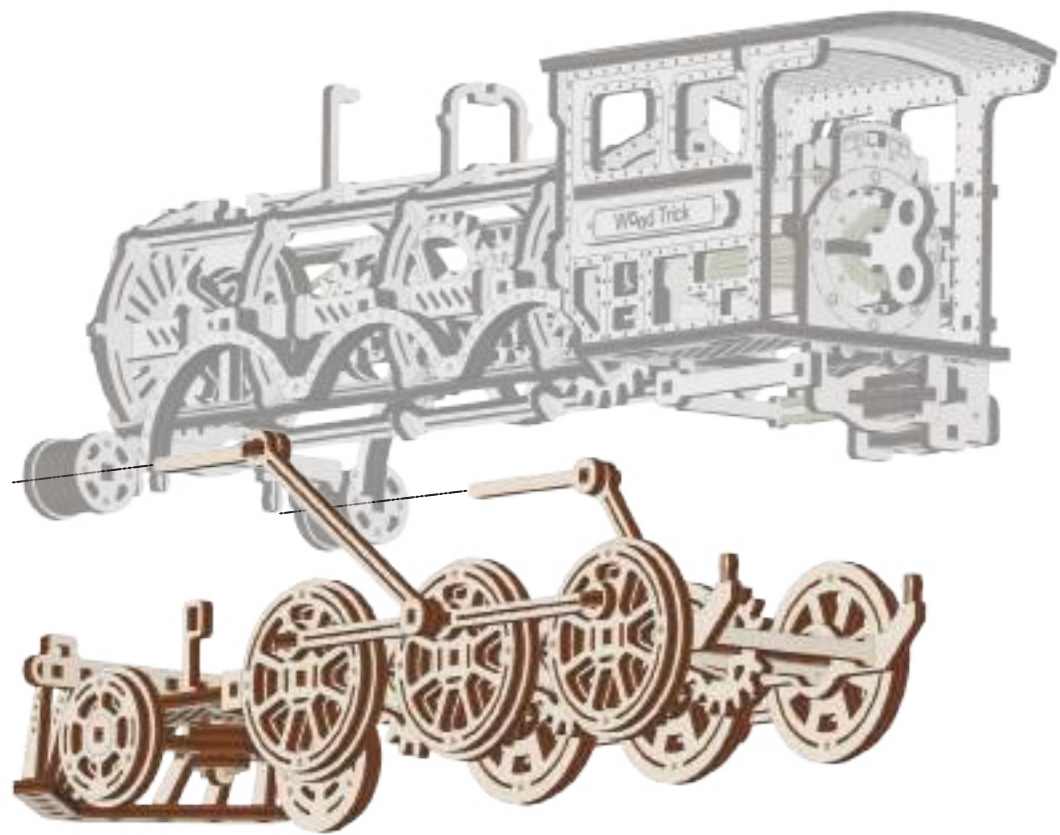

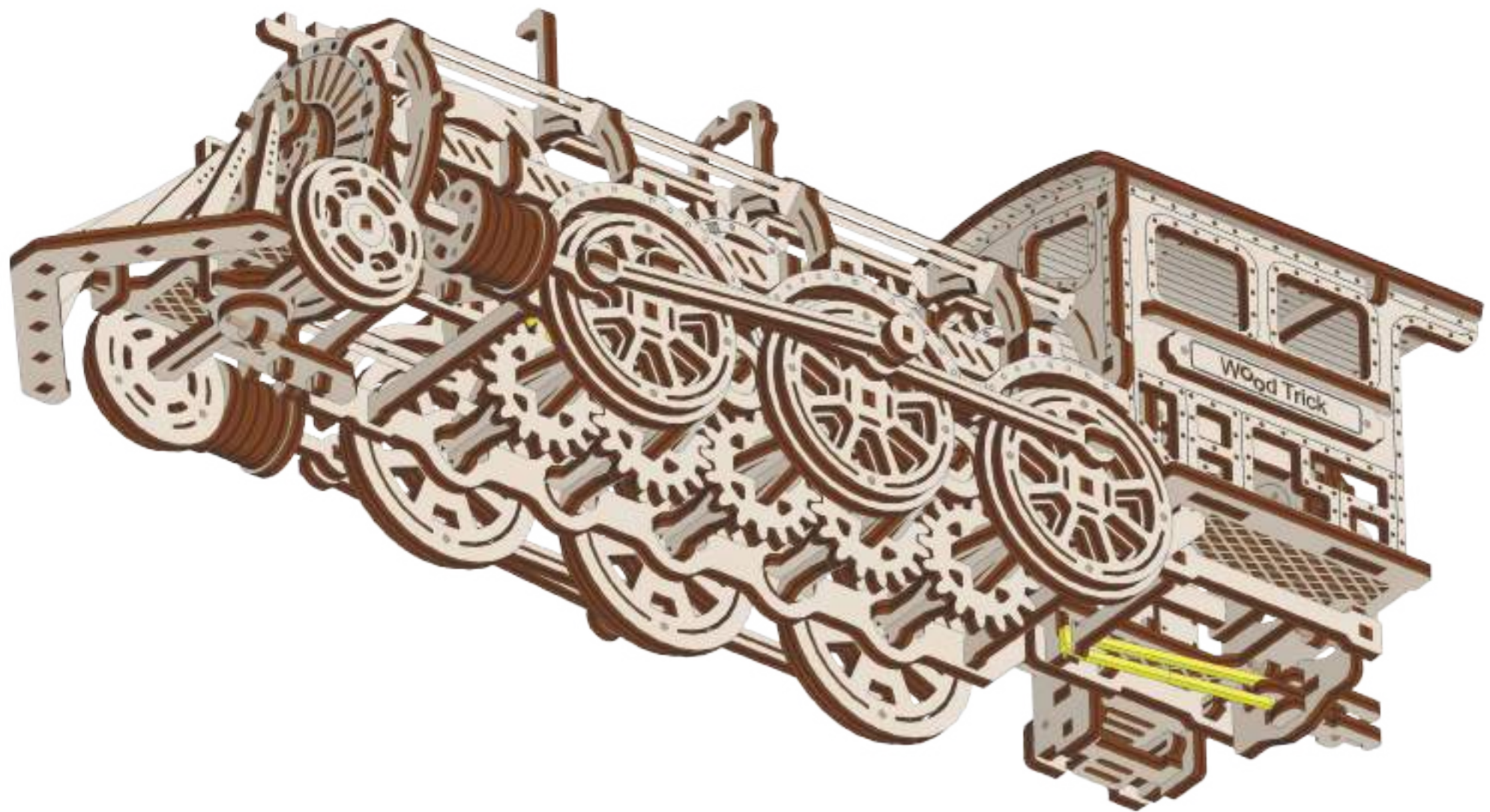

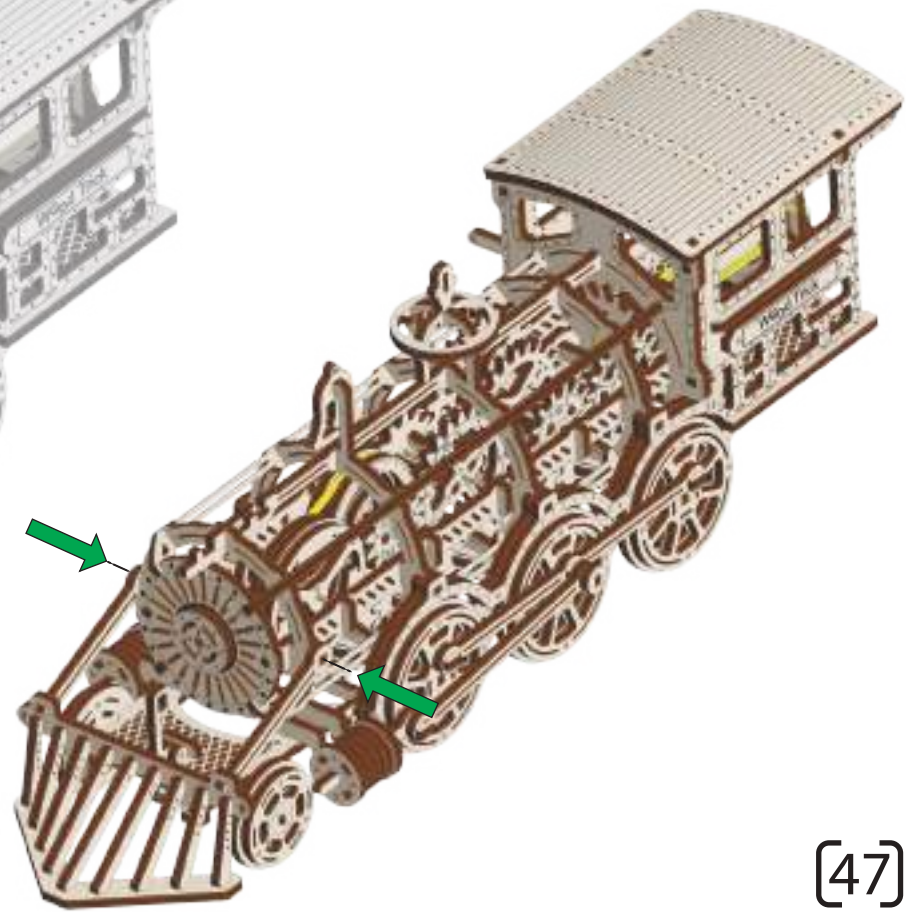
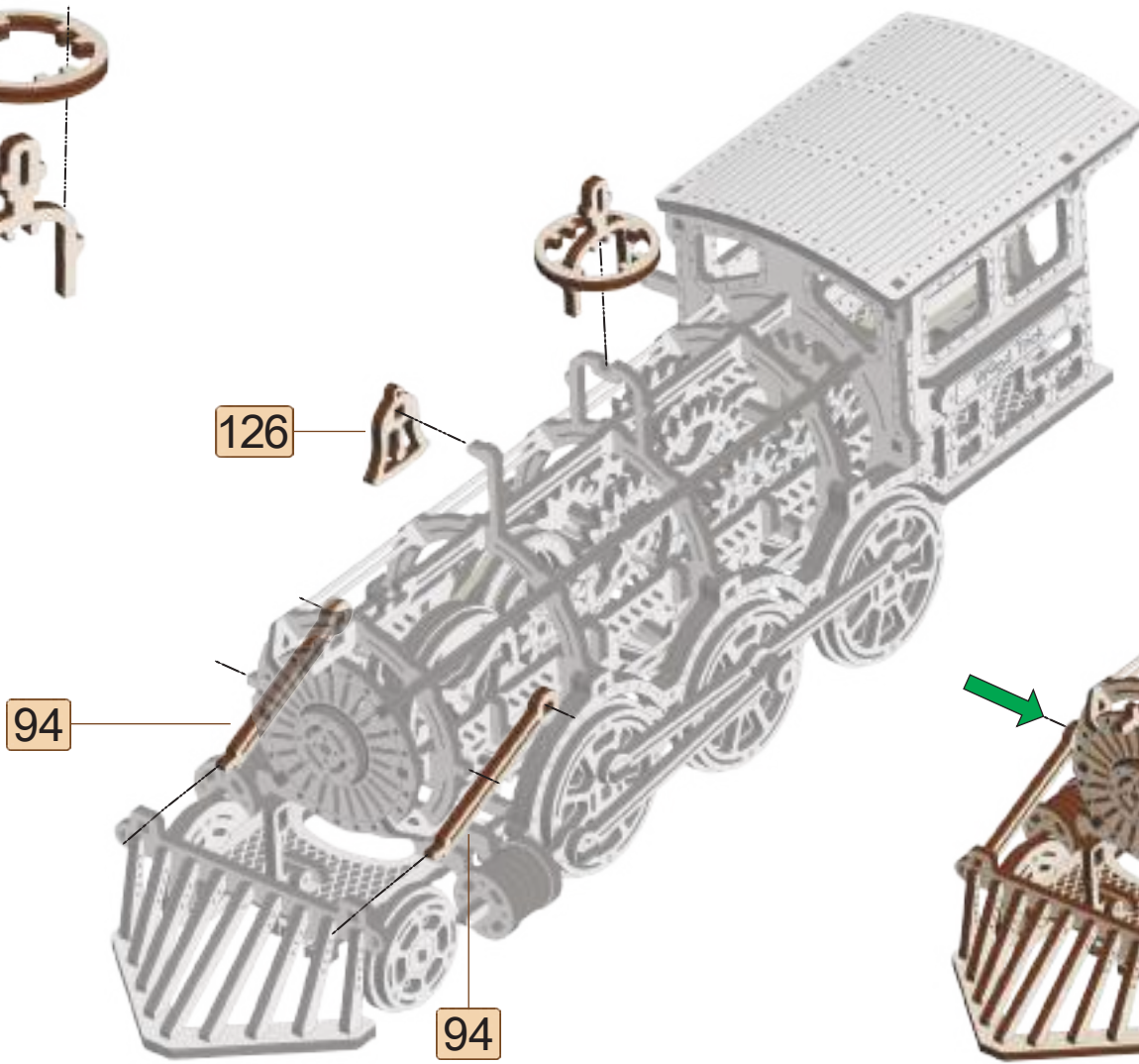
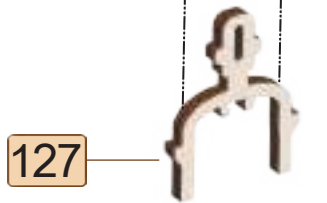
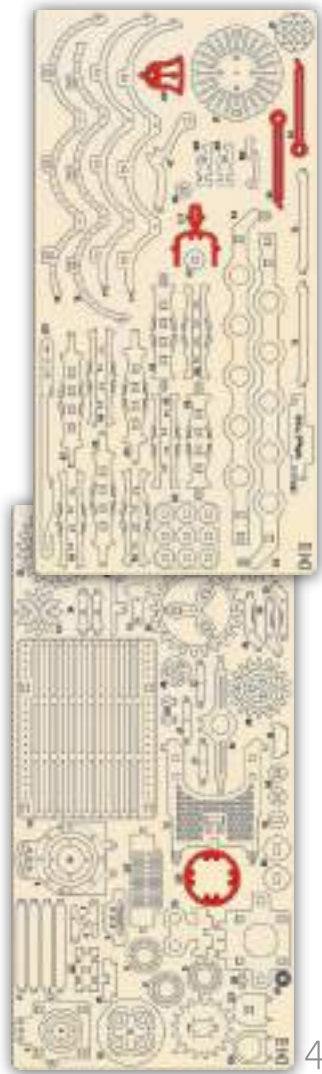





5



4

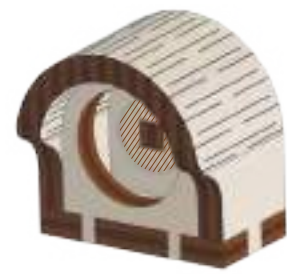
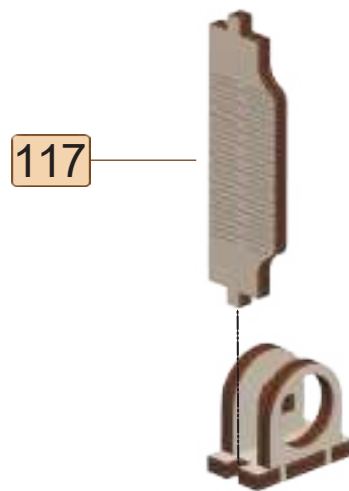
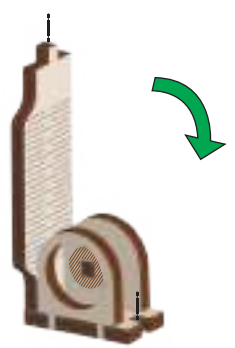
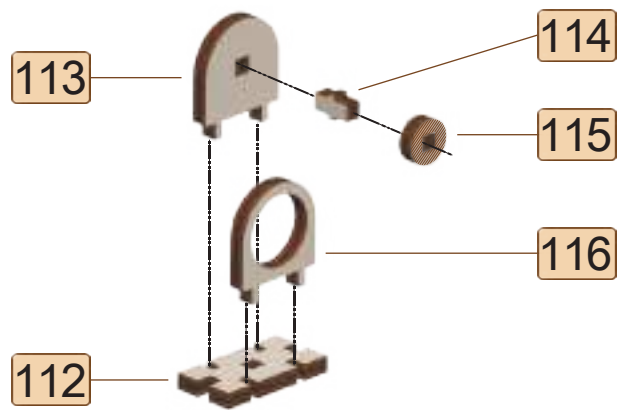
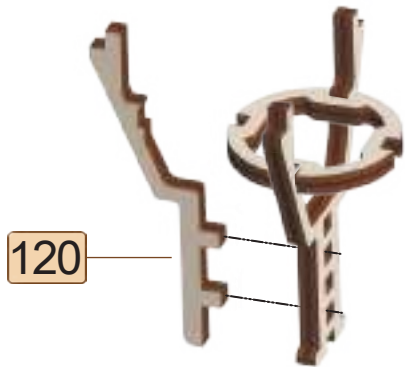

[48]

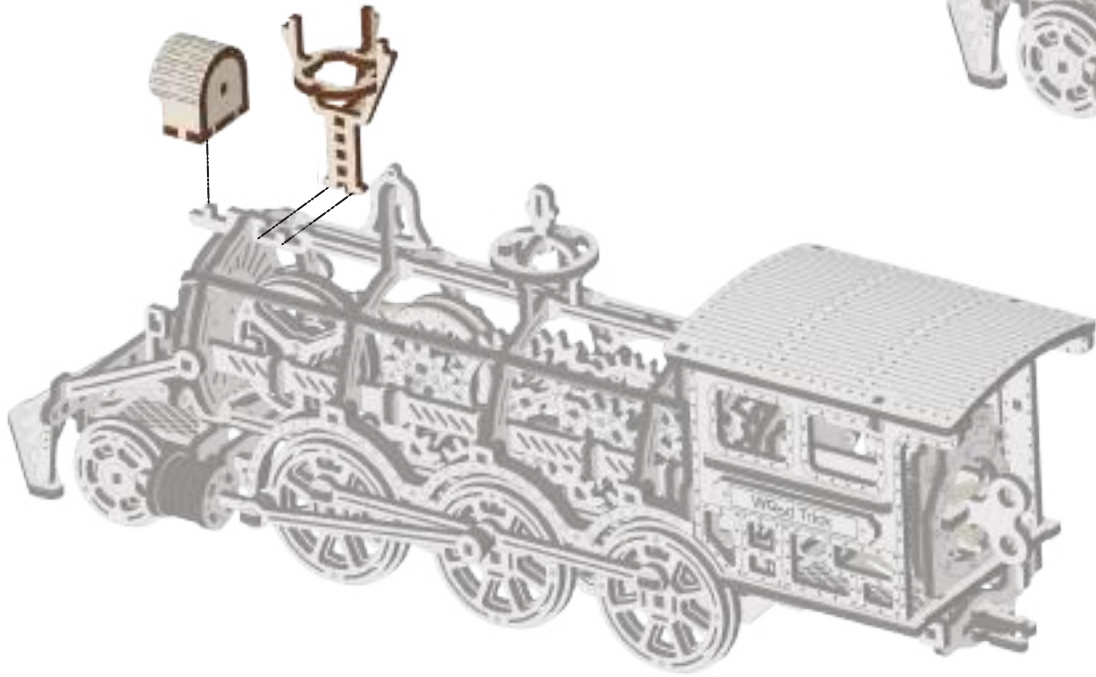

121

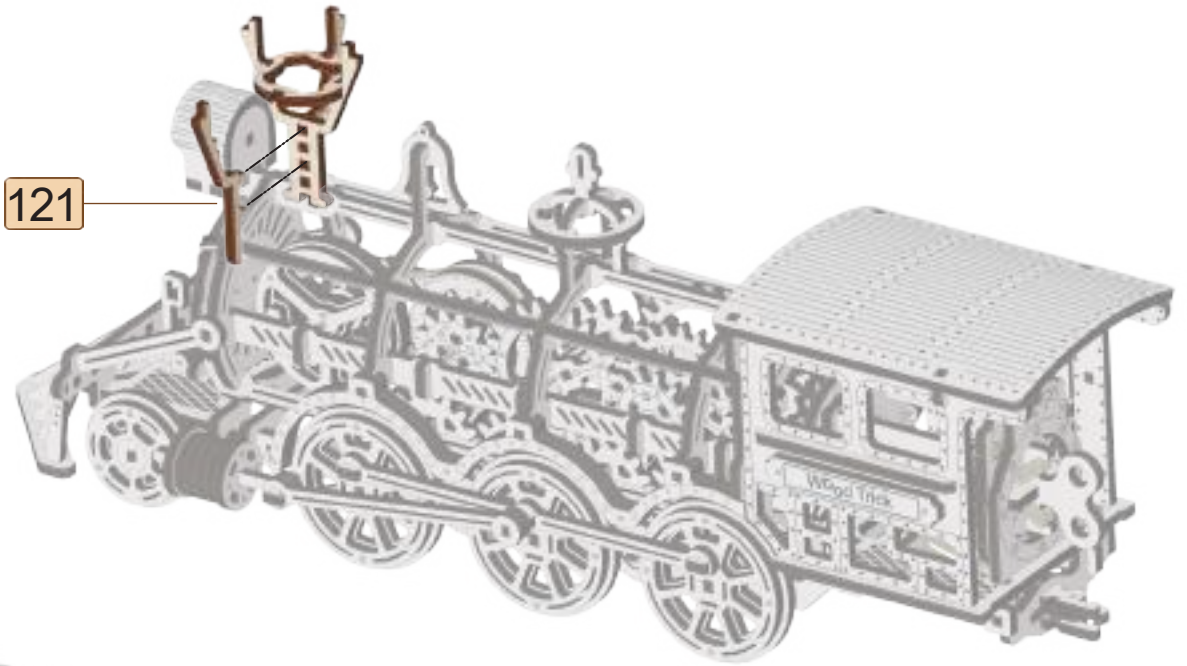

125



124



123



122

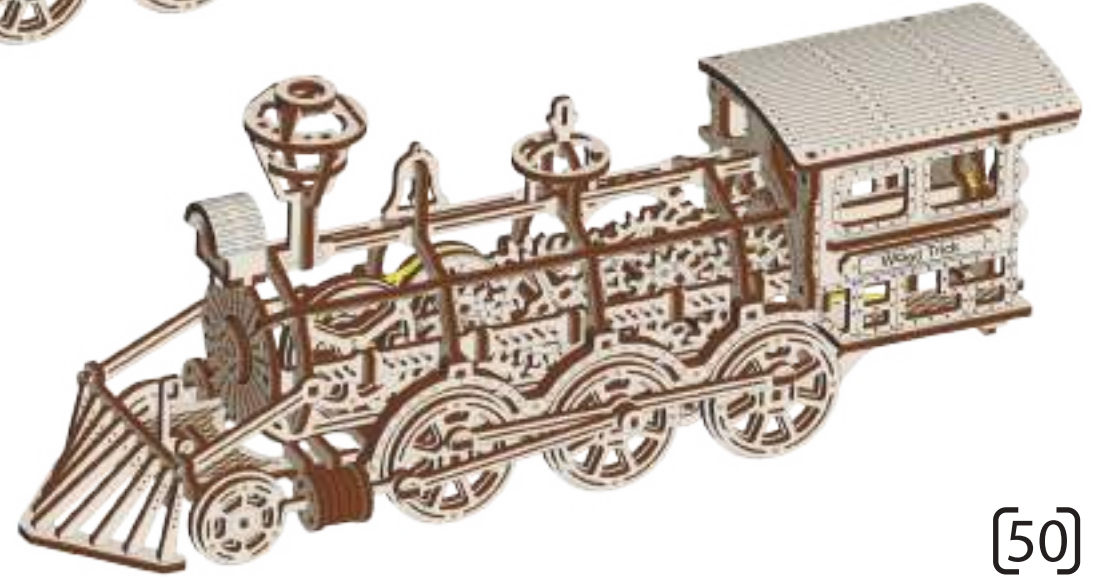
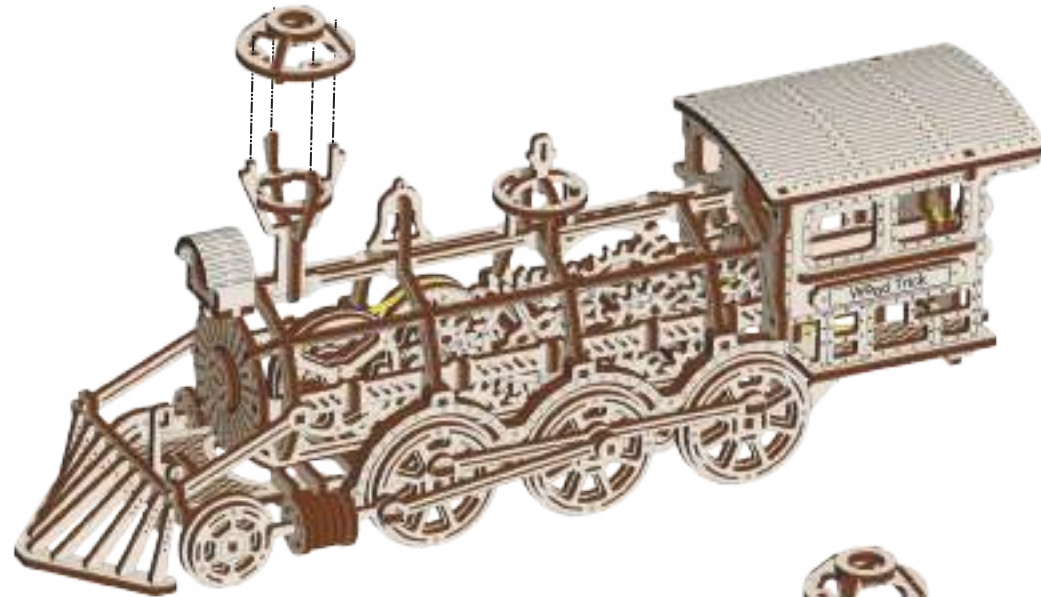

5



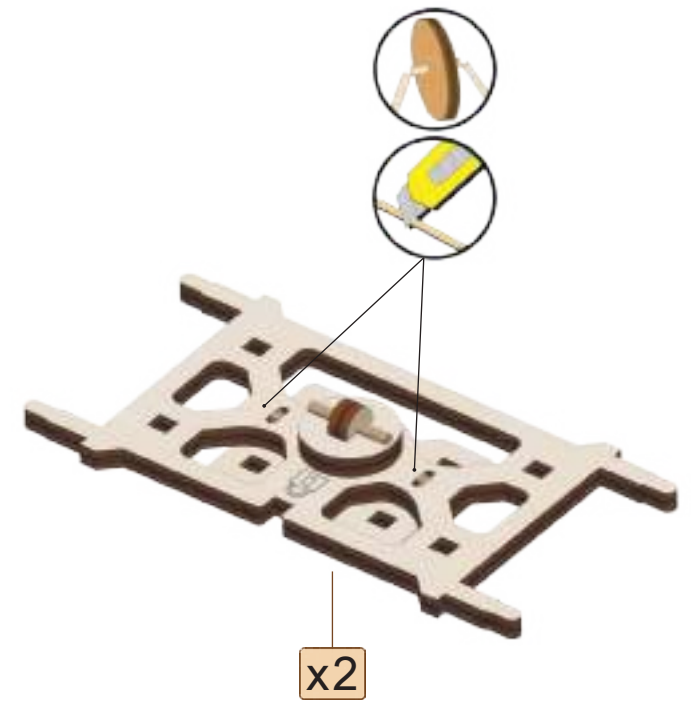
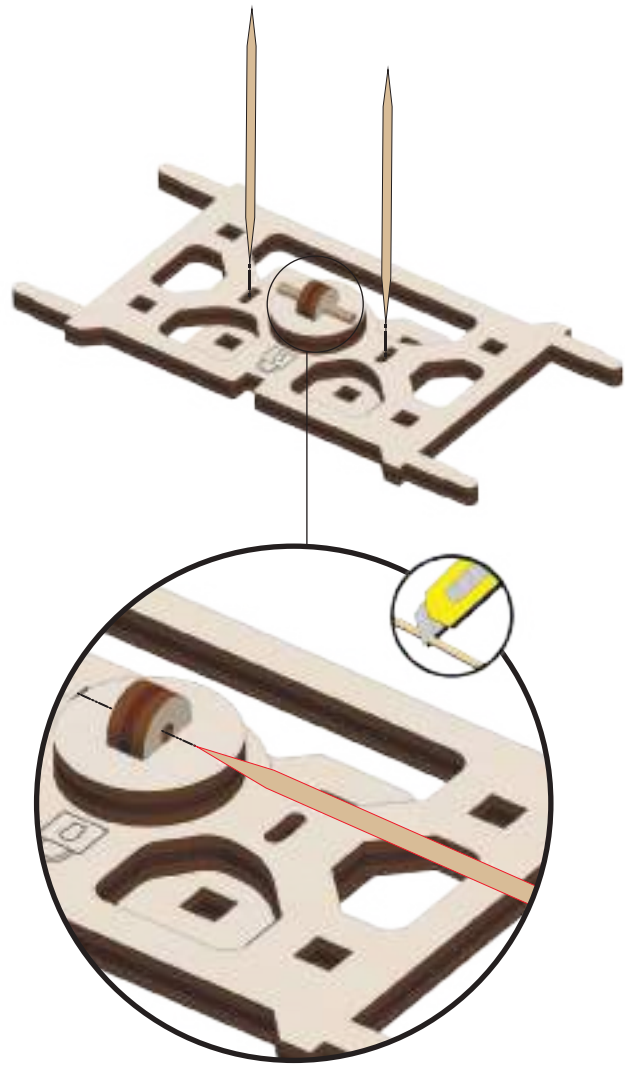
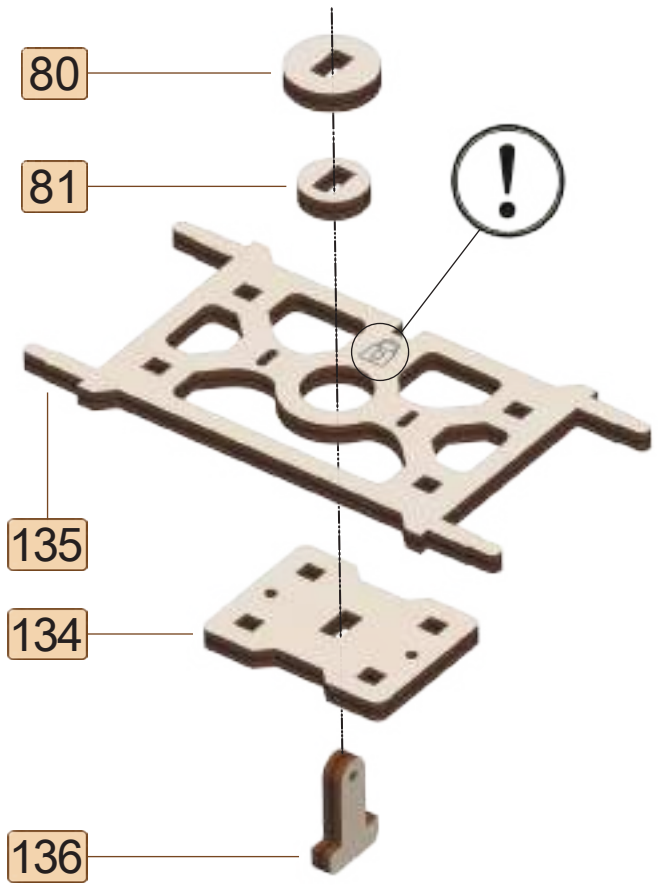
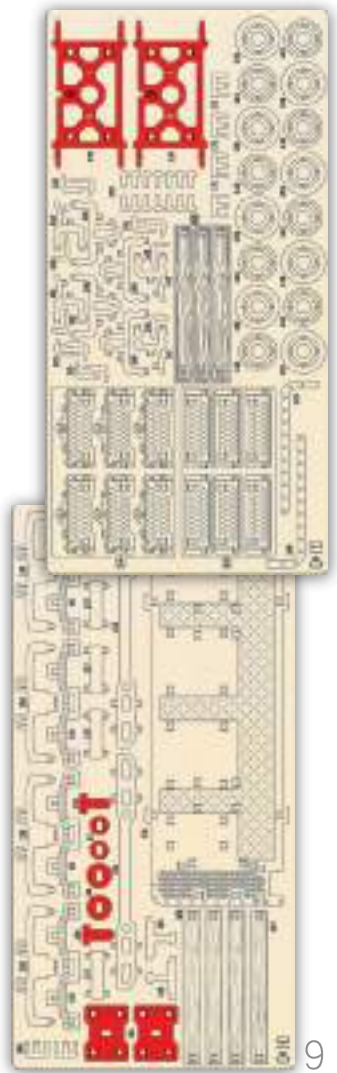

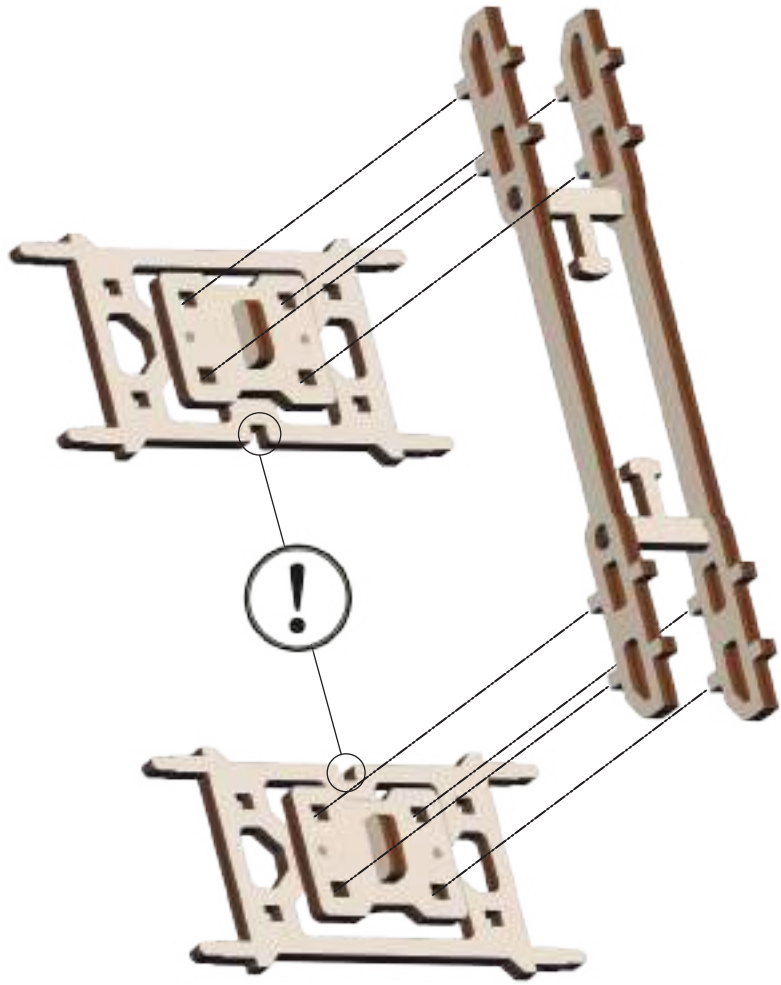
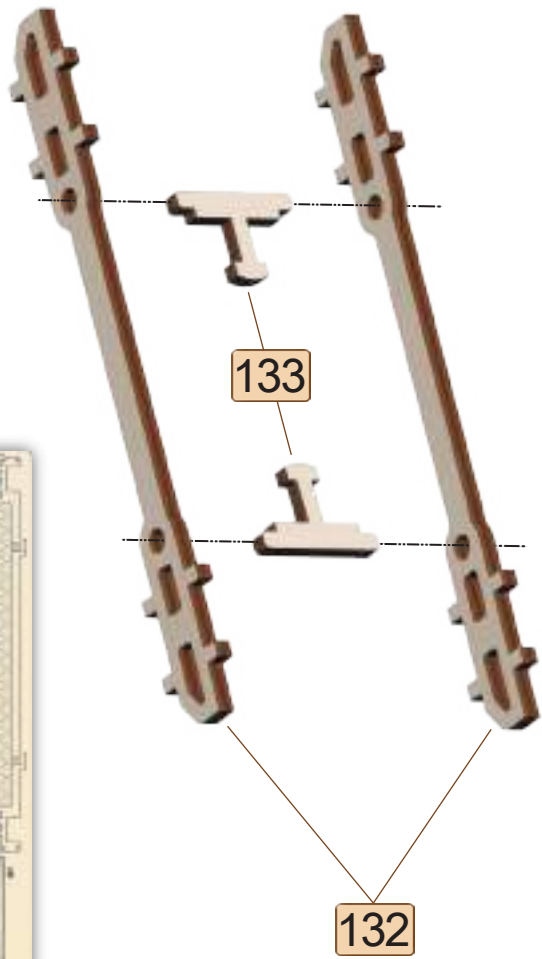

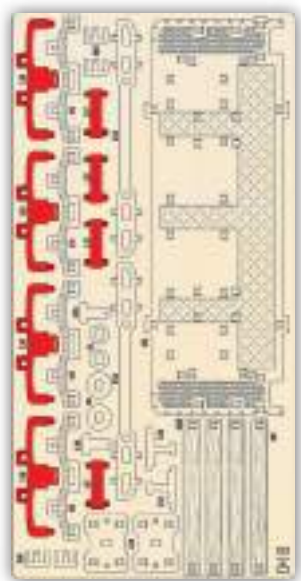

138

137

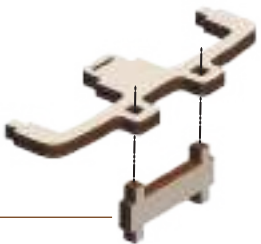

x4

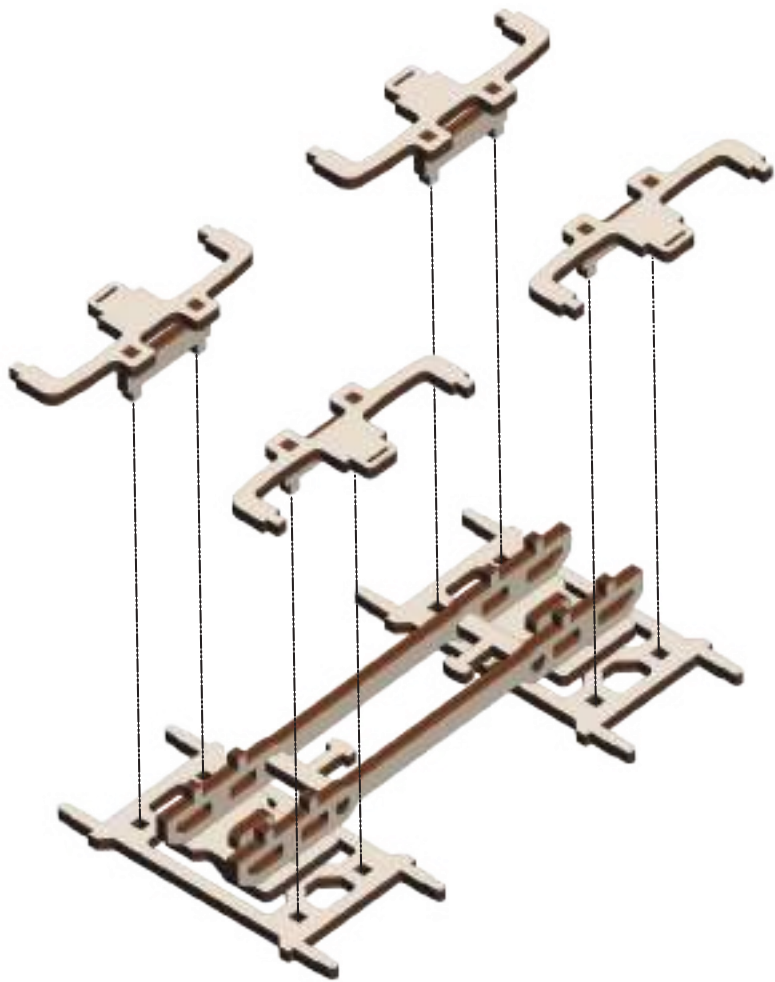

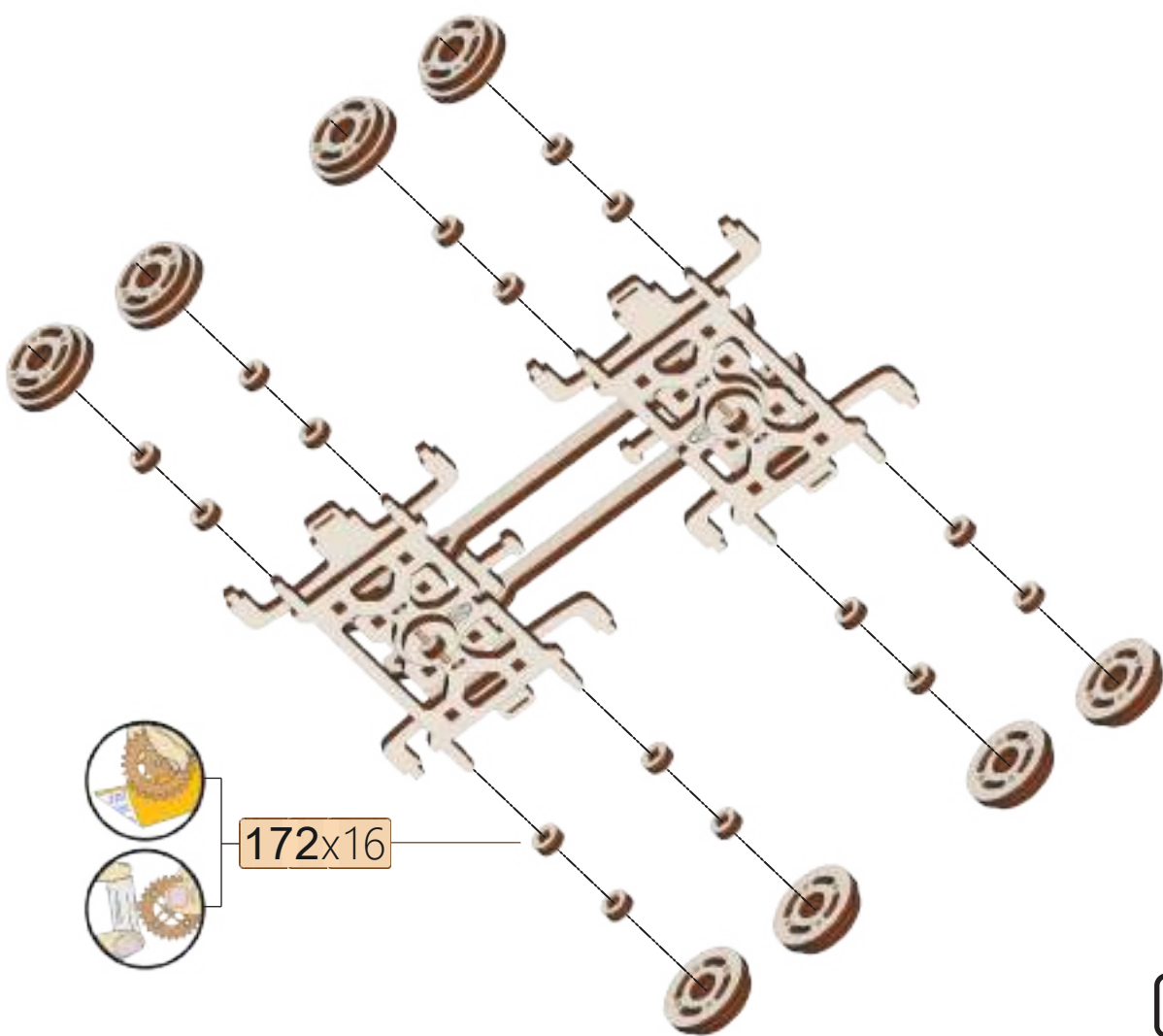
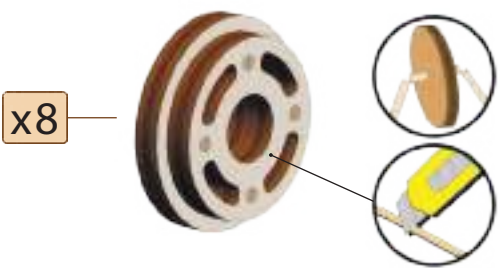
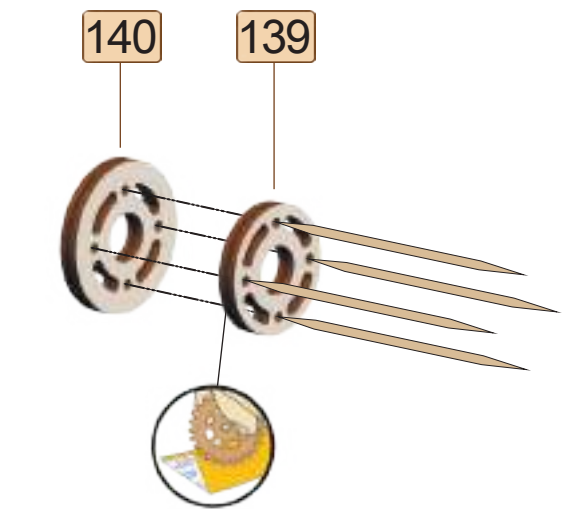
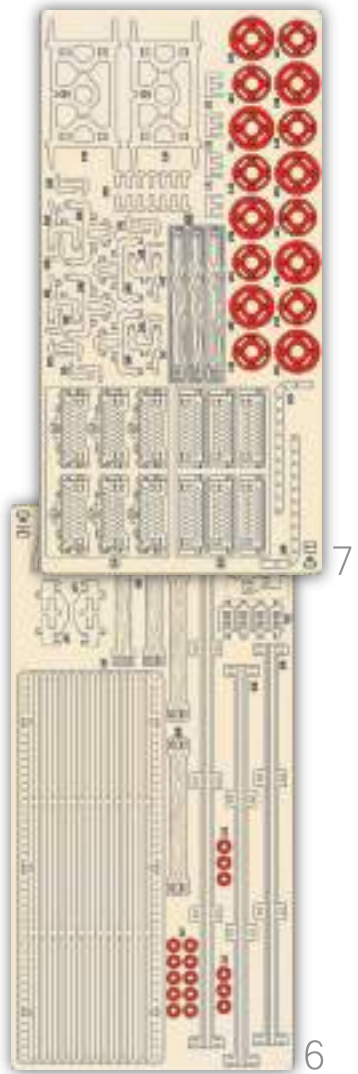

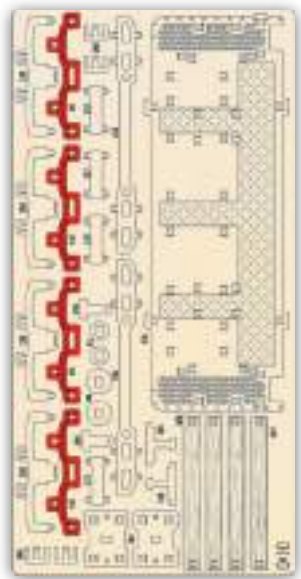

9

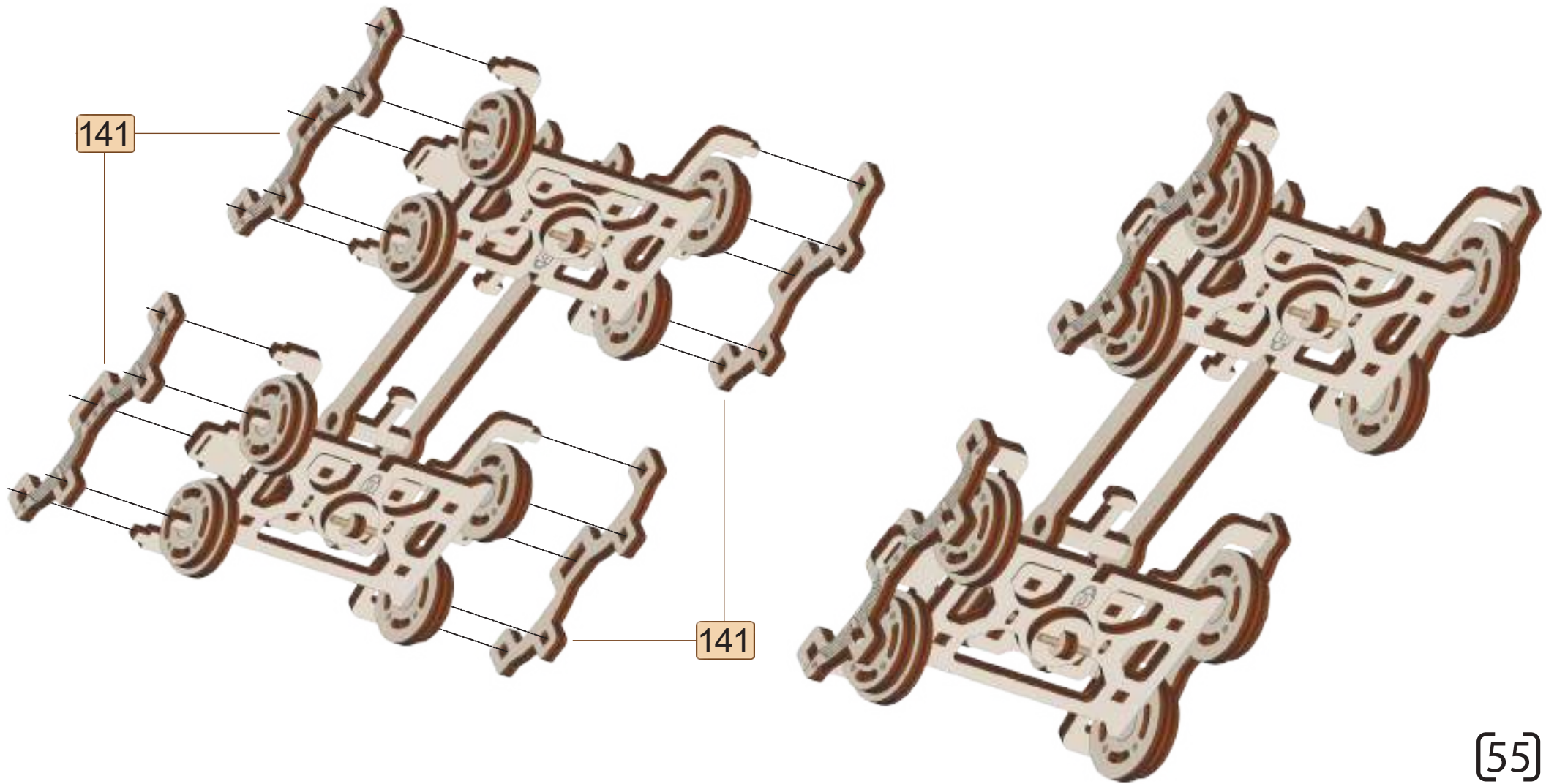



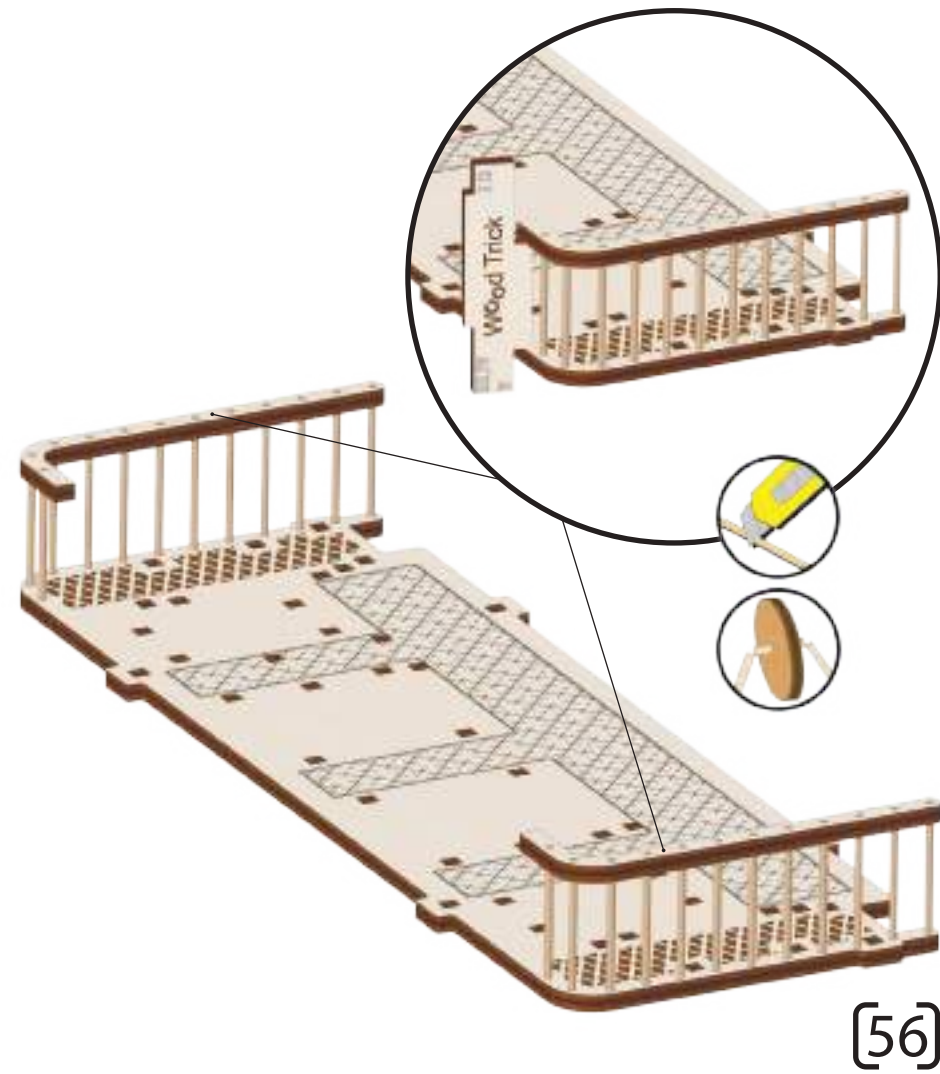
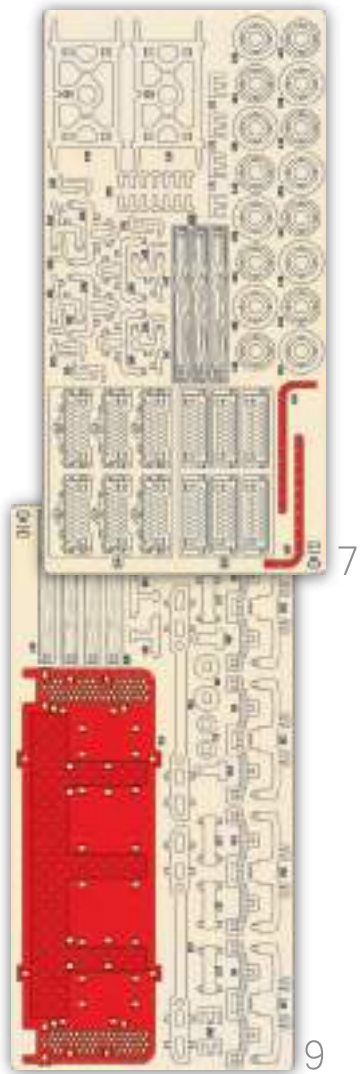

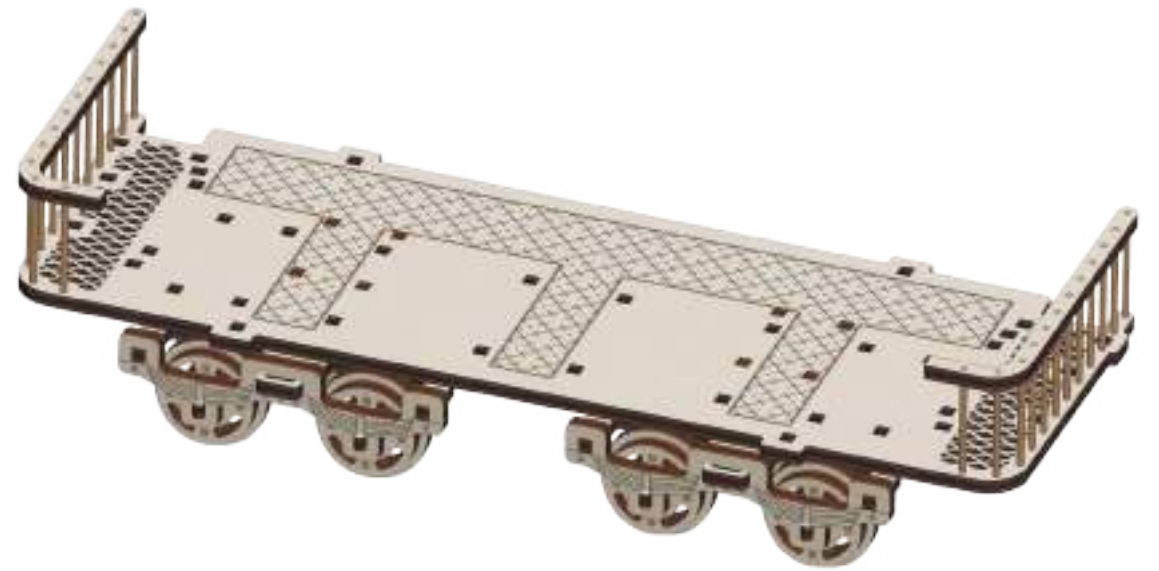
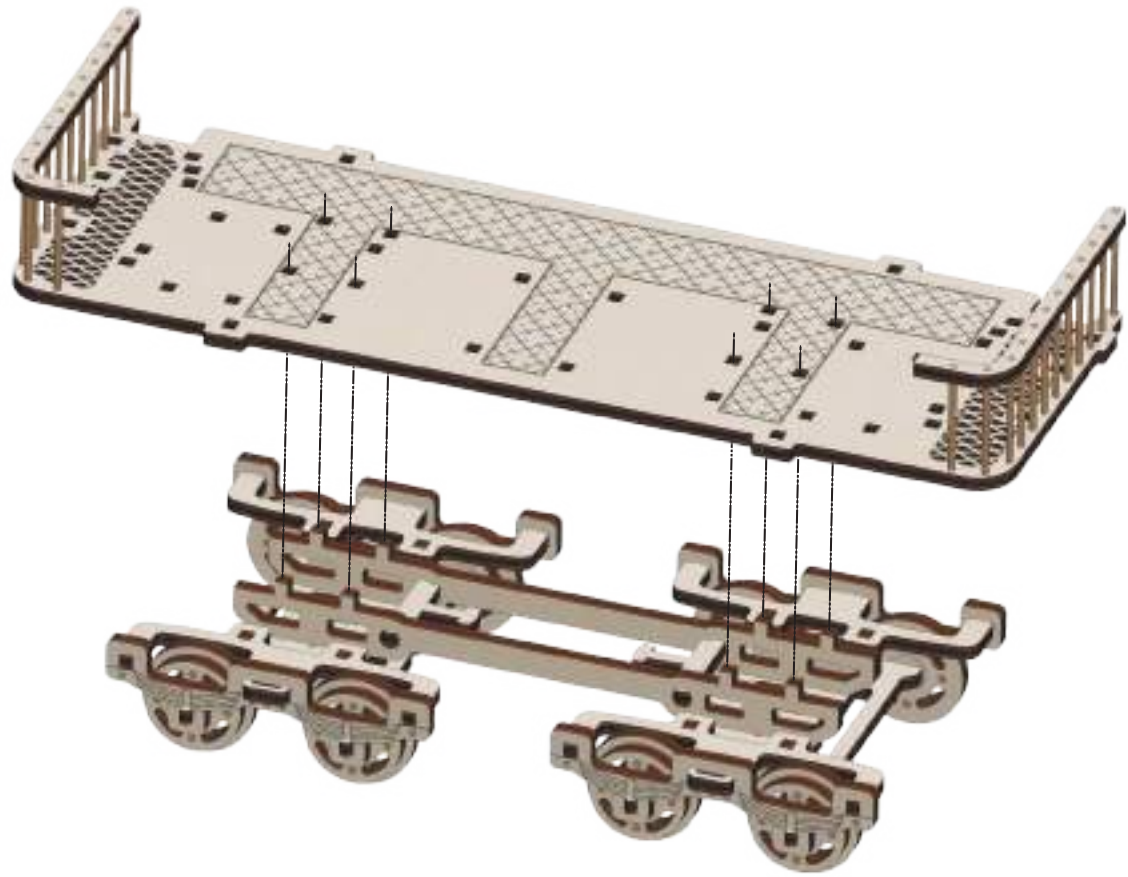

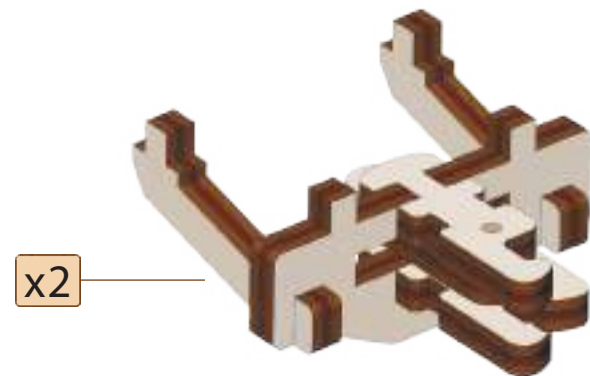
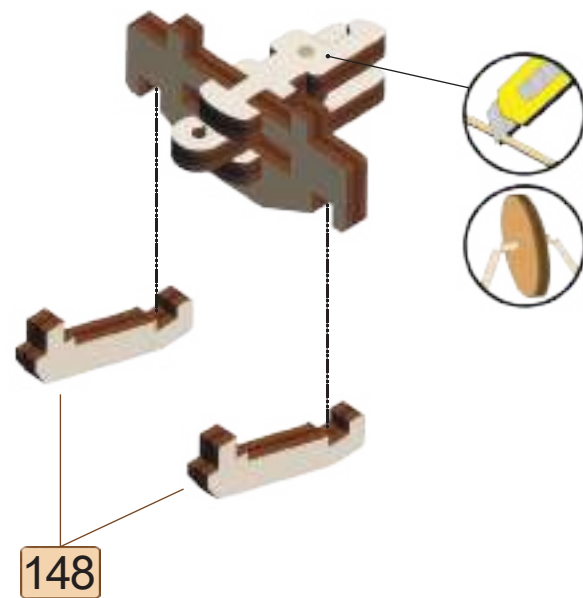
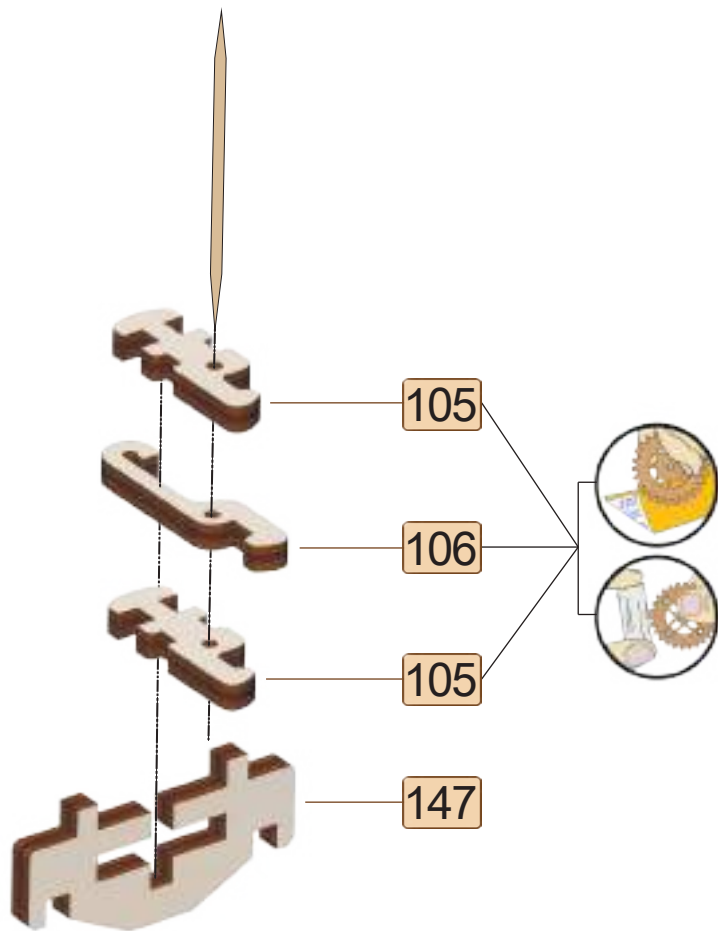
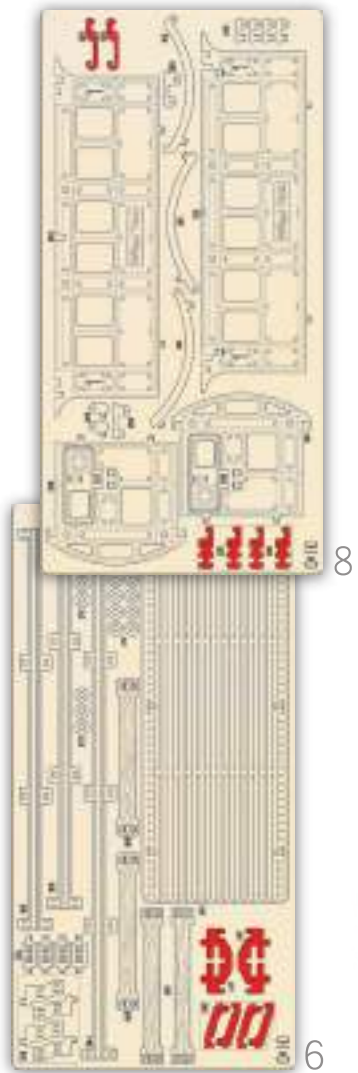

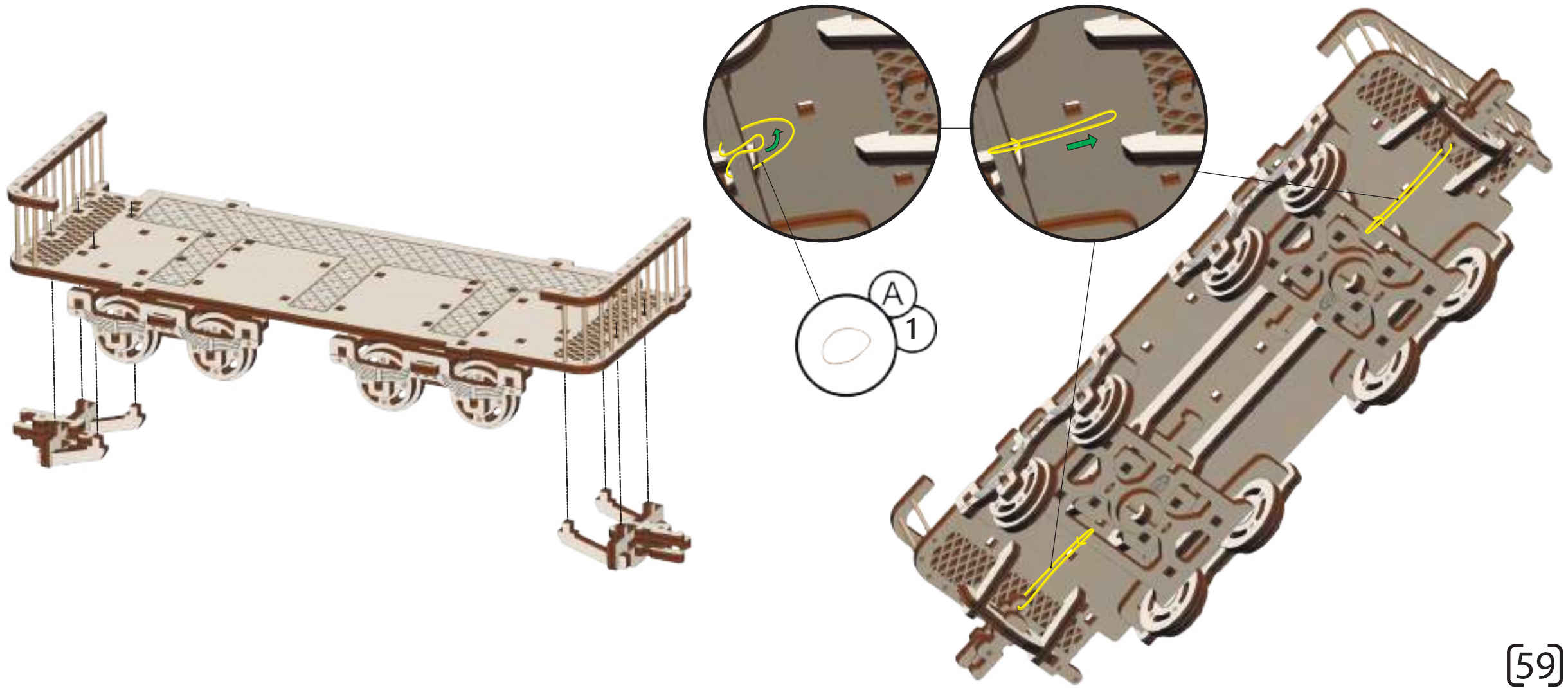

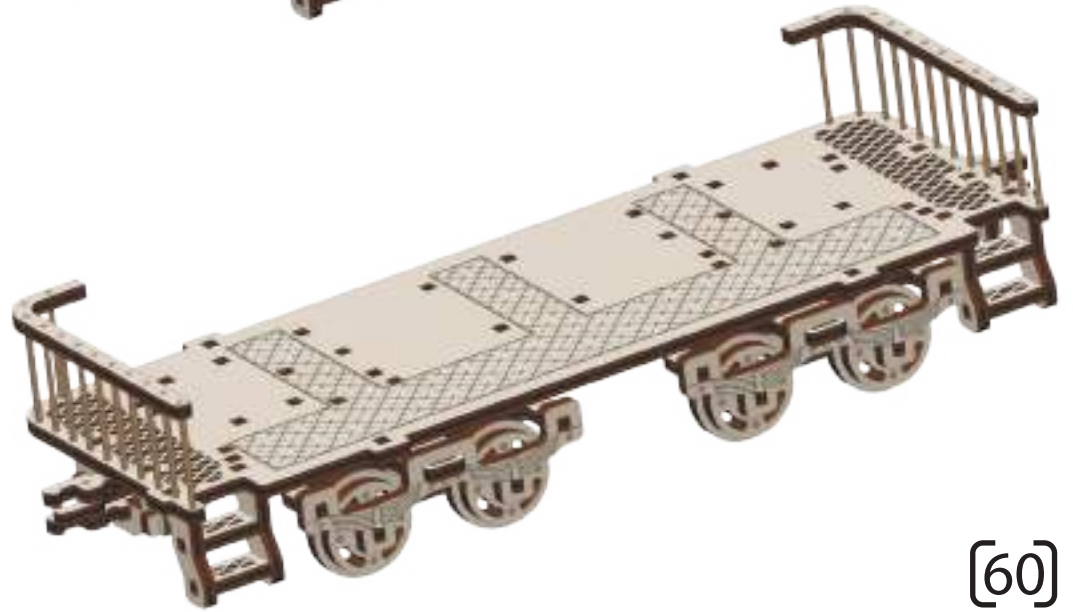
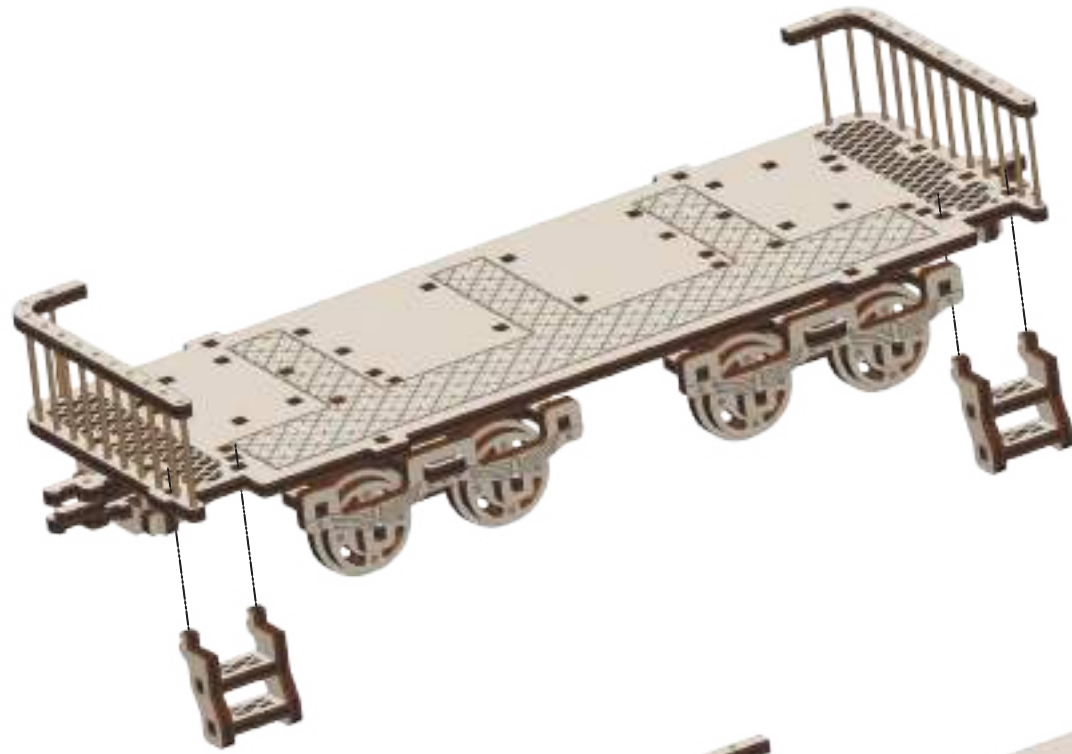
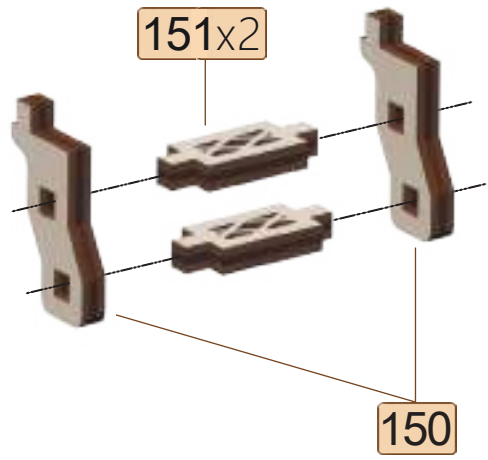

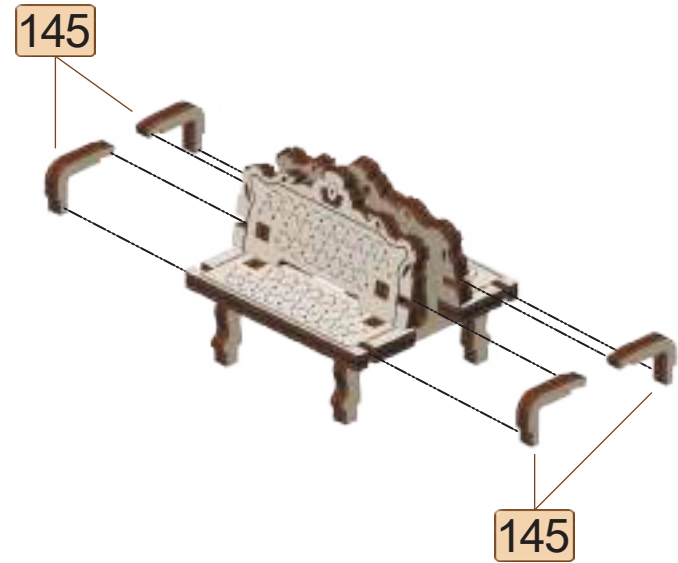
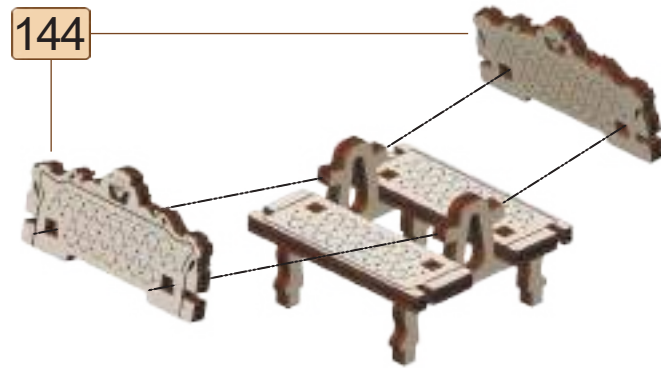
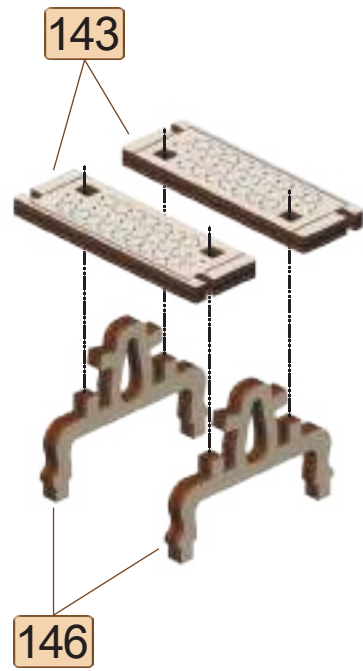
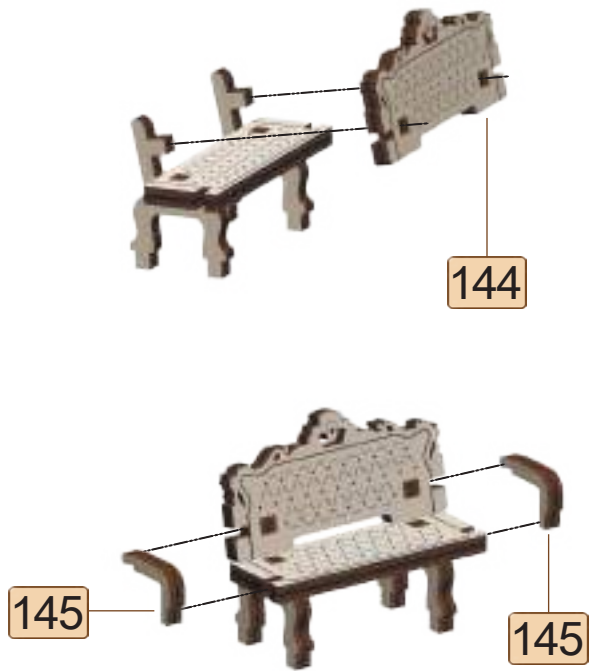
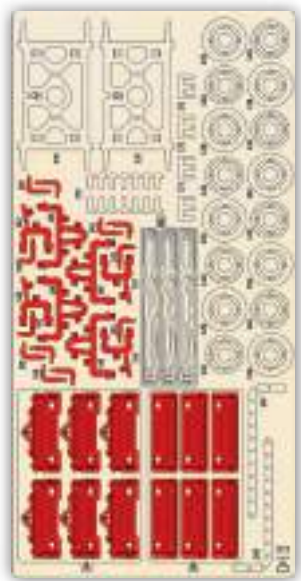
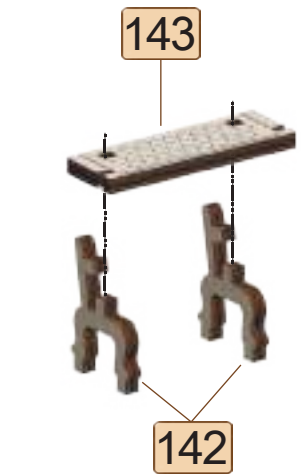

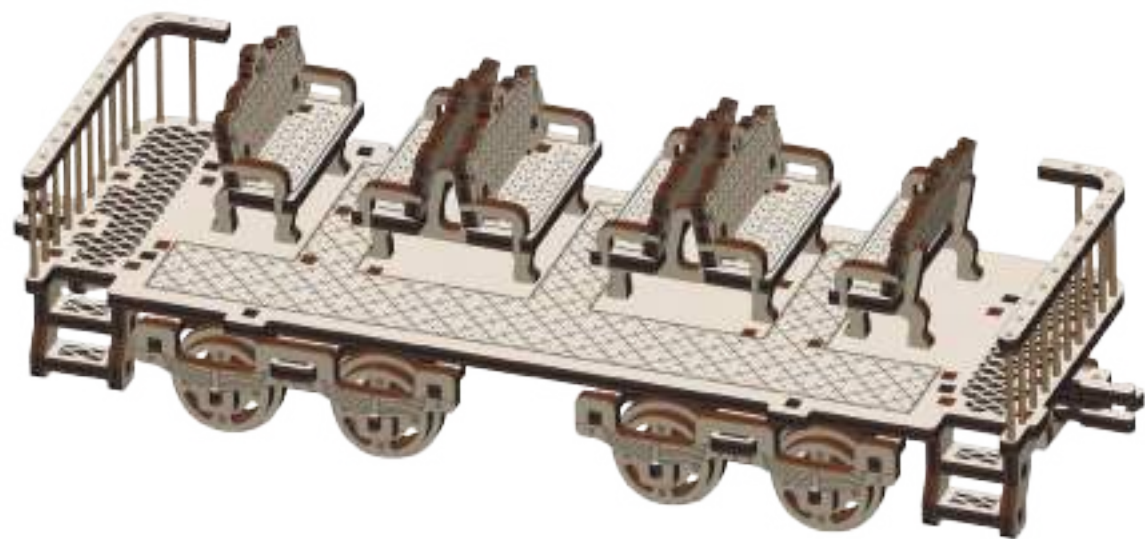
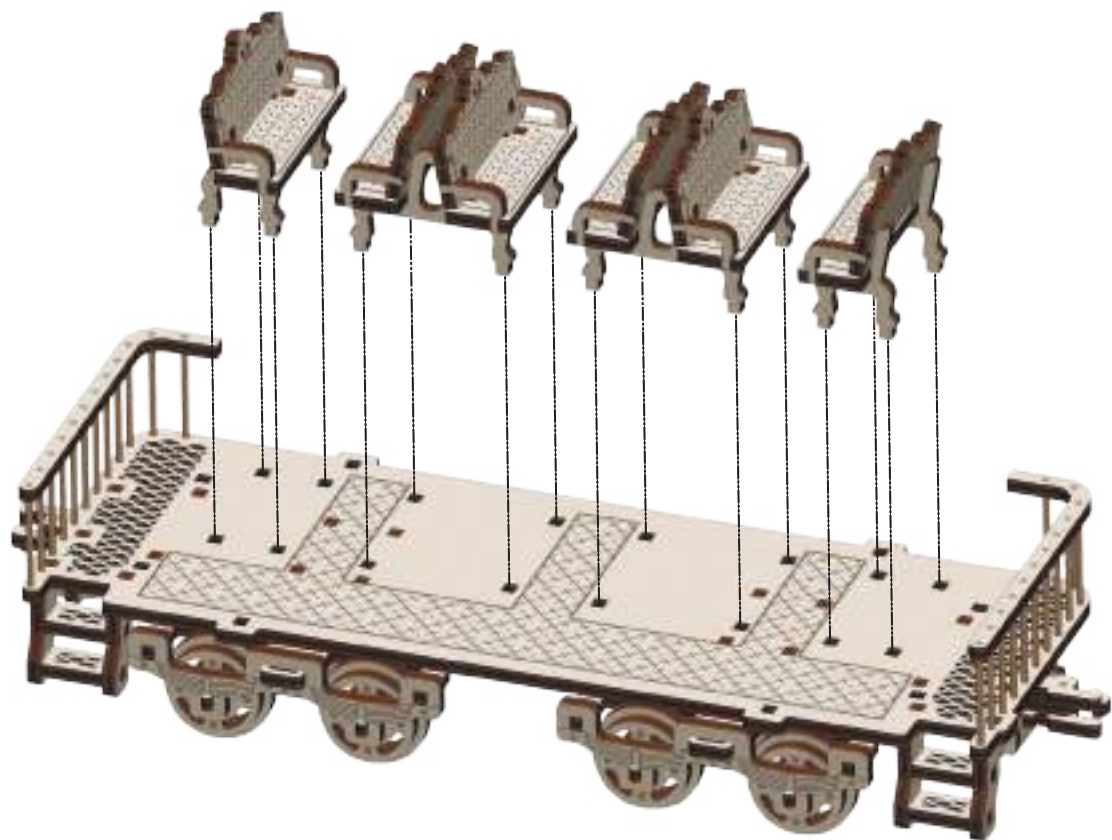

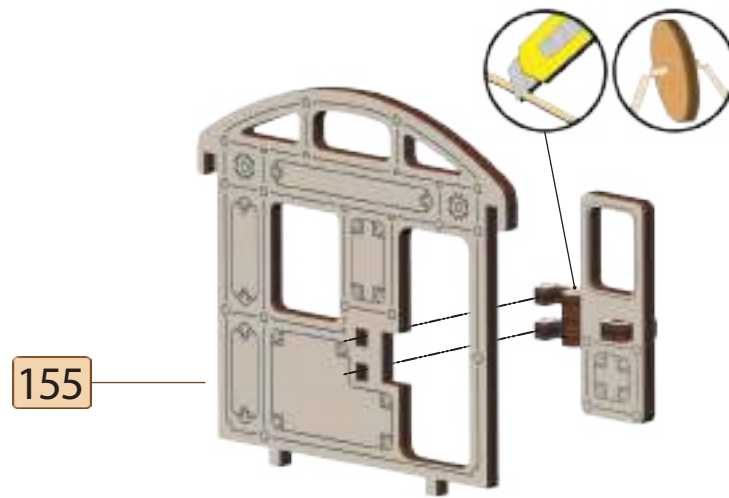
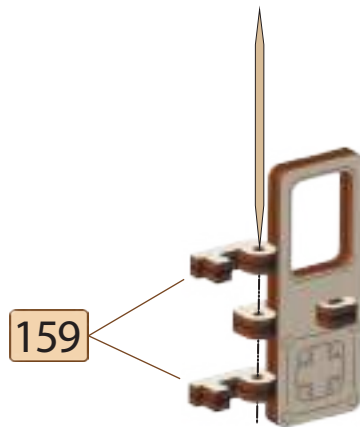
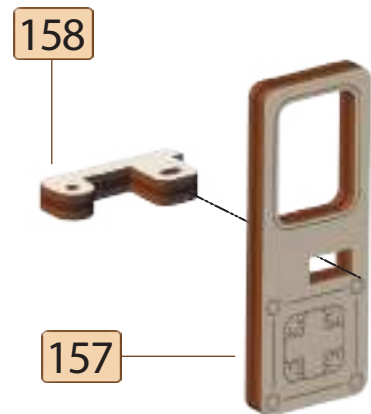
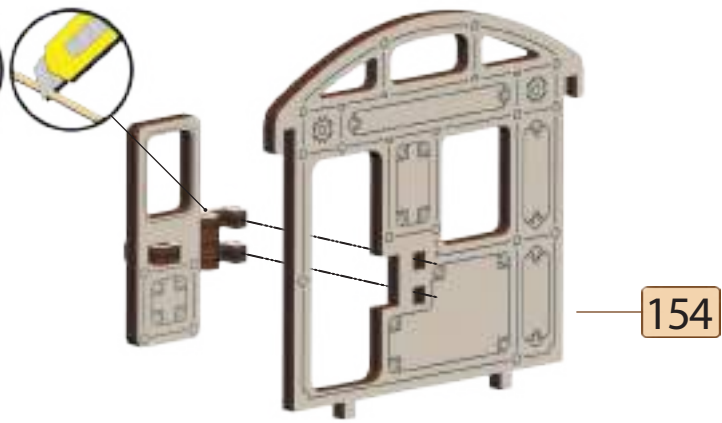
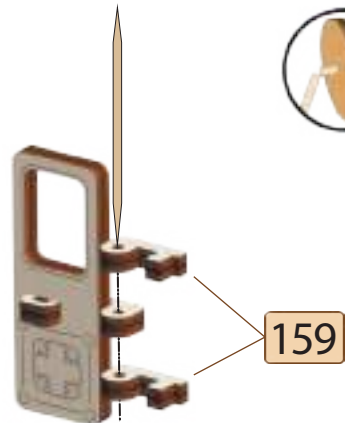
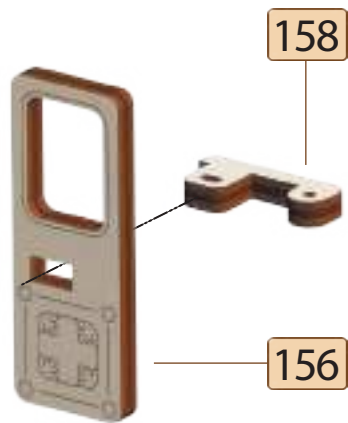



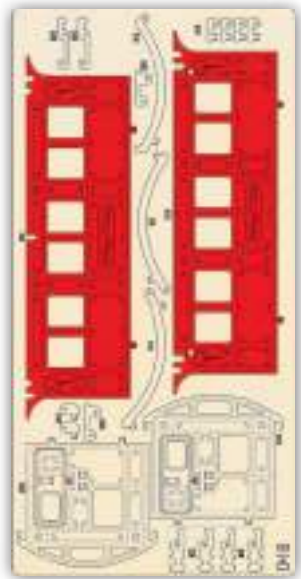

8

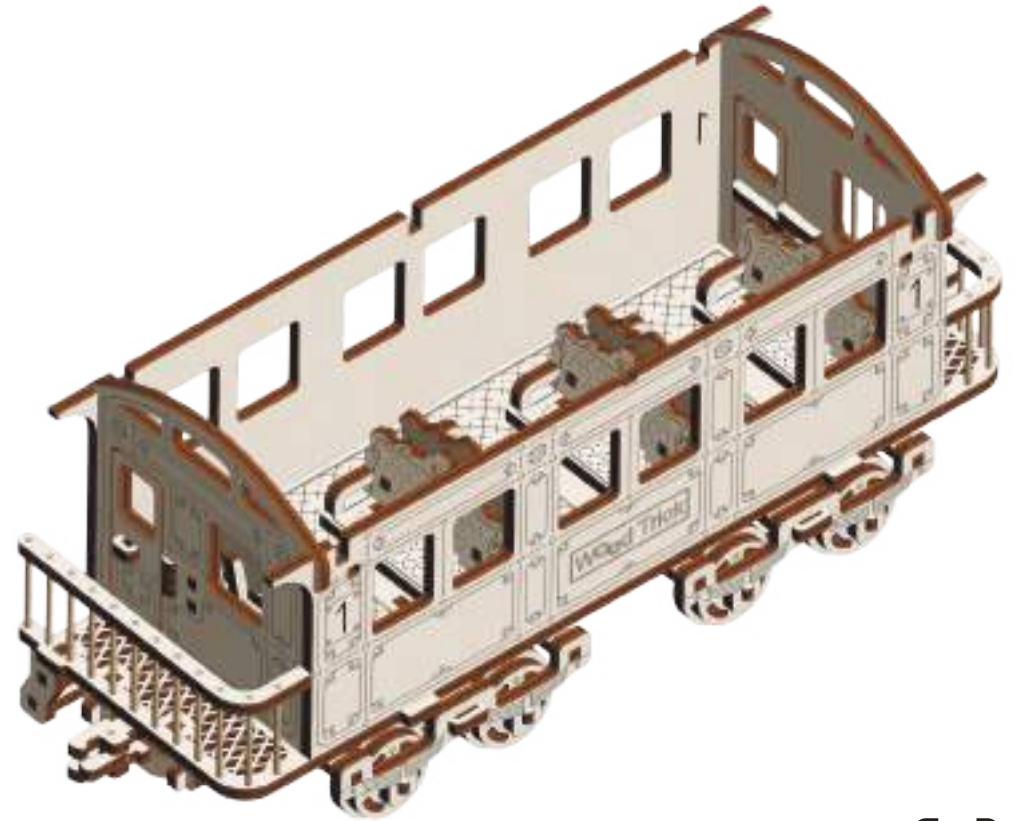
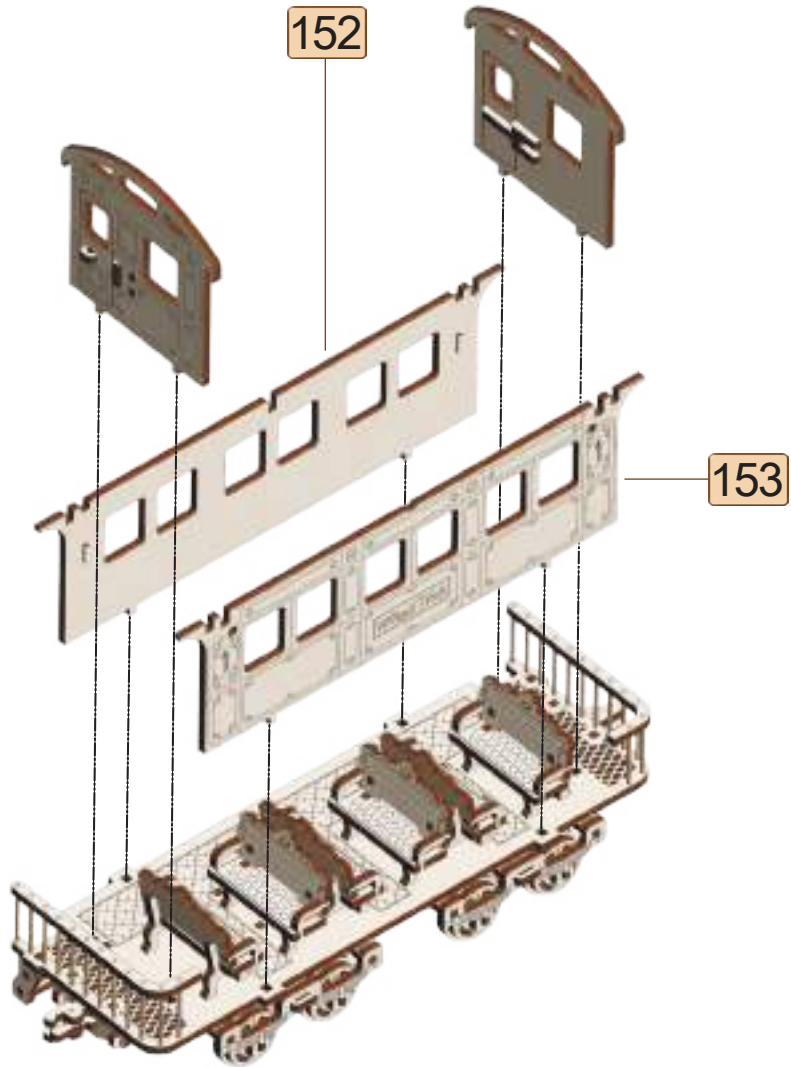

[64]

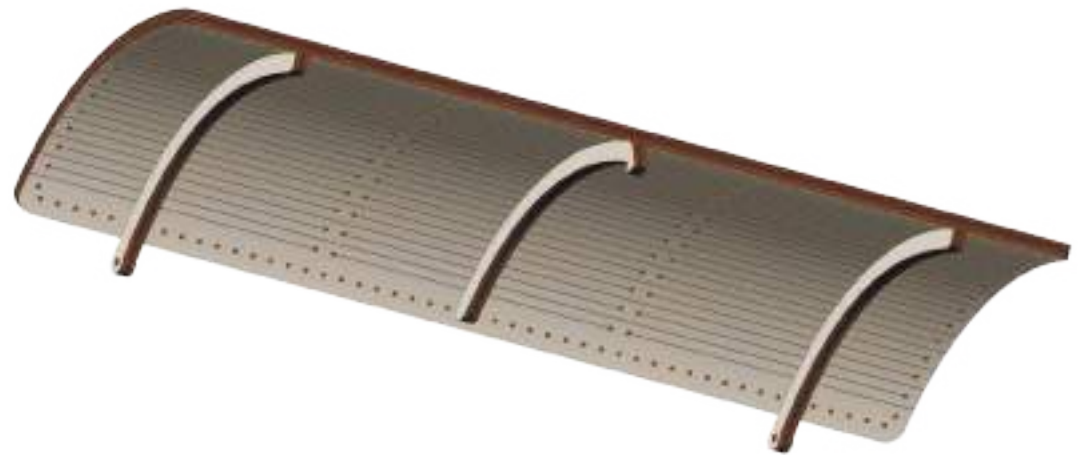
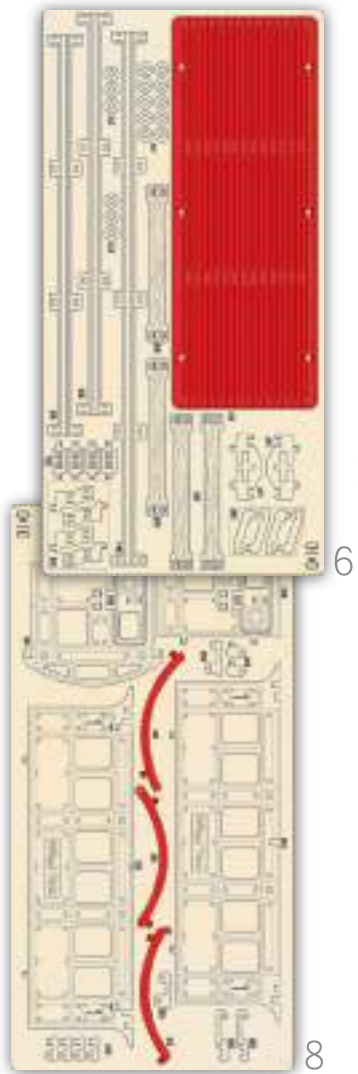

160

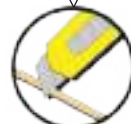
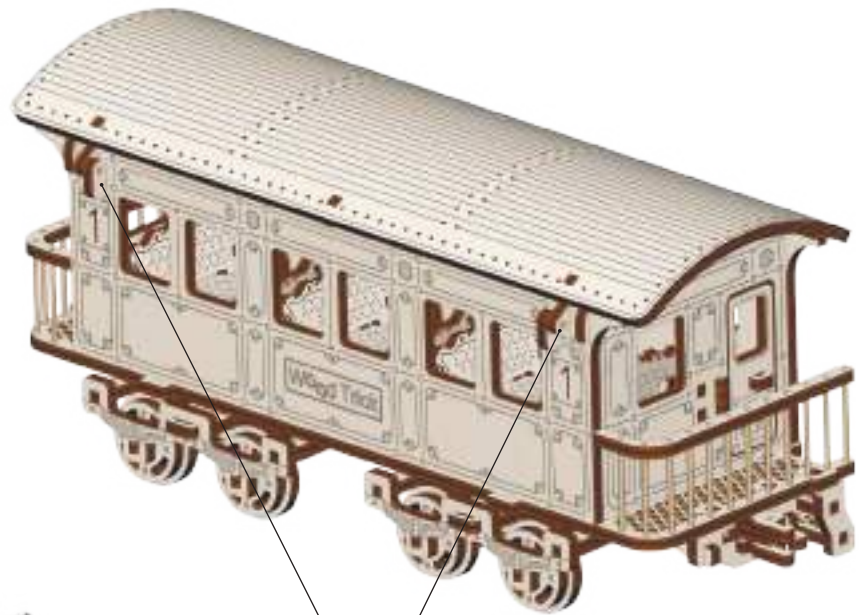
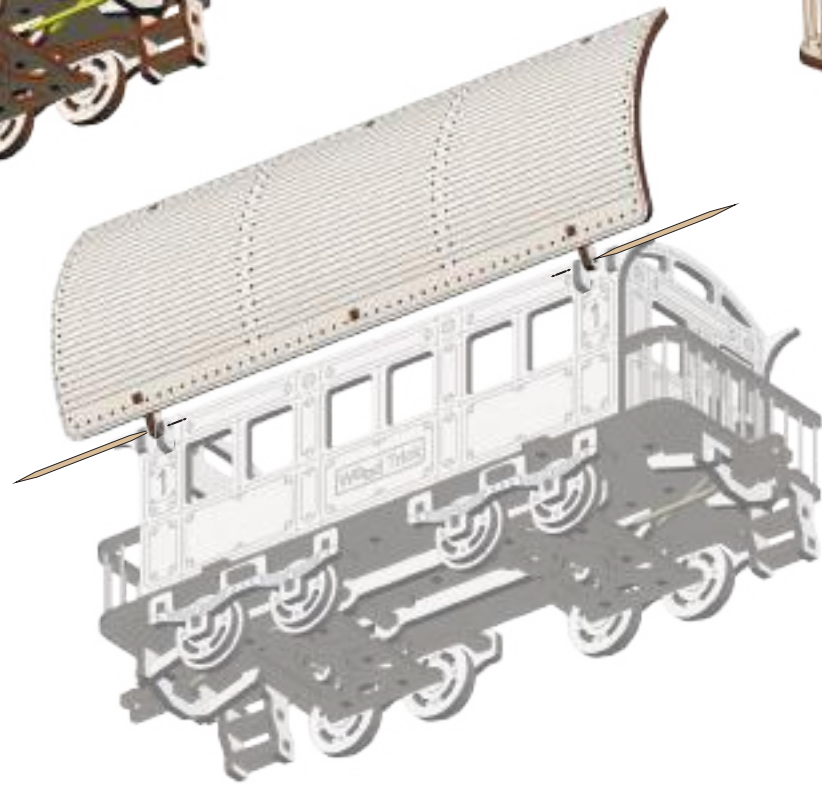
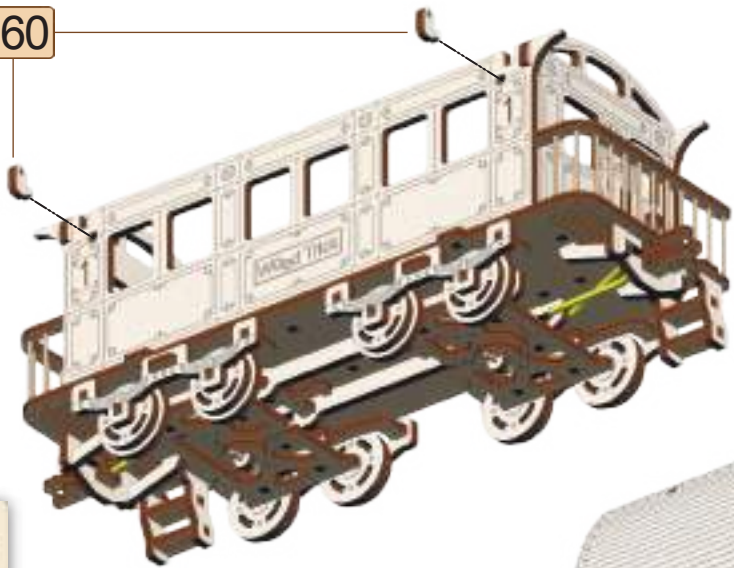

8

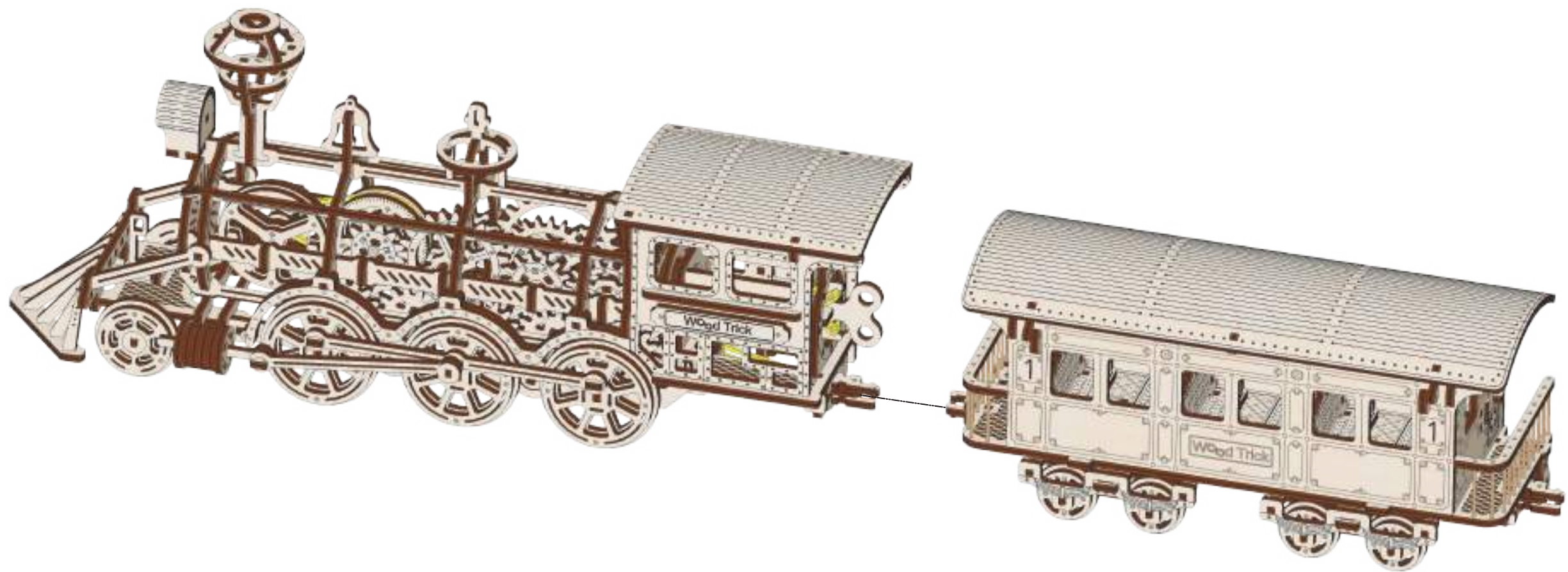

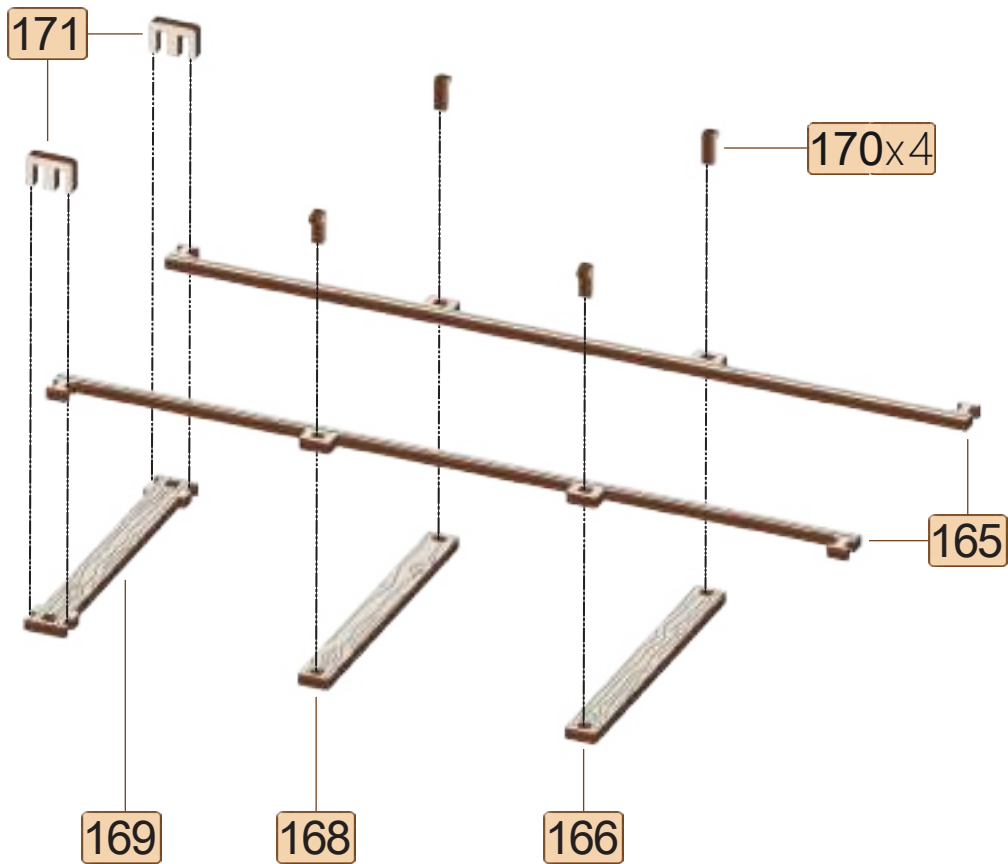
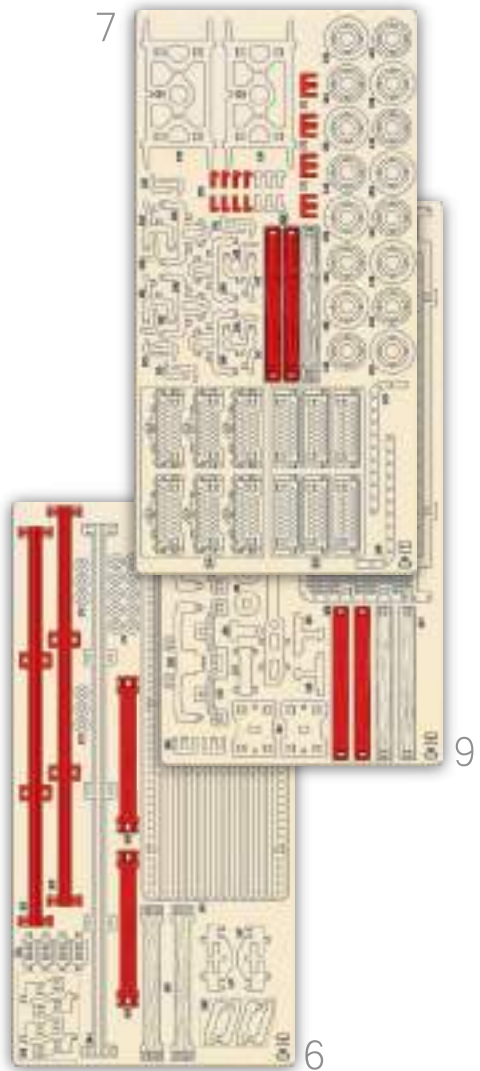

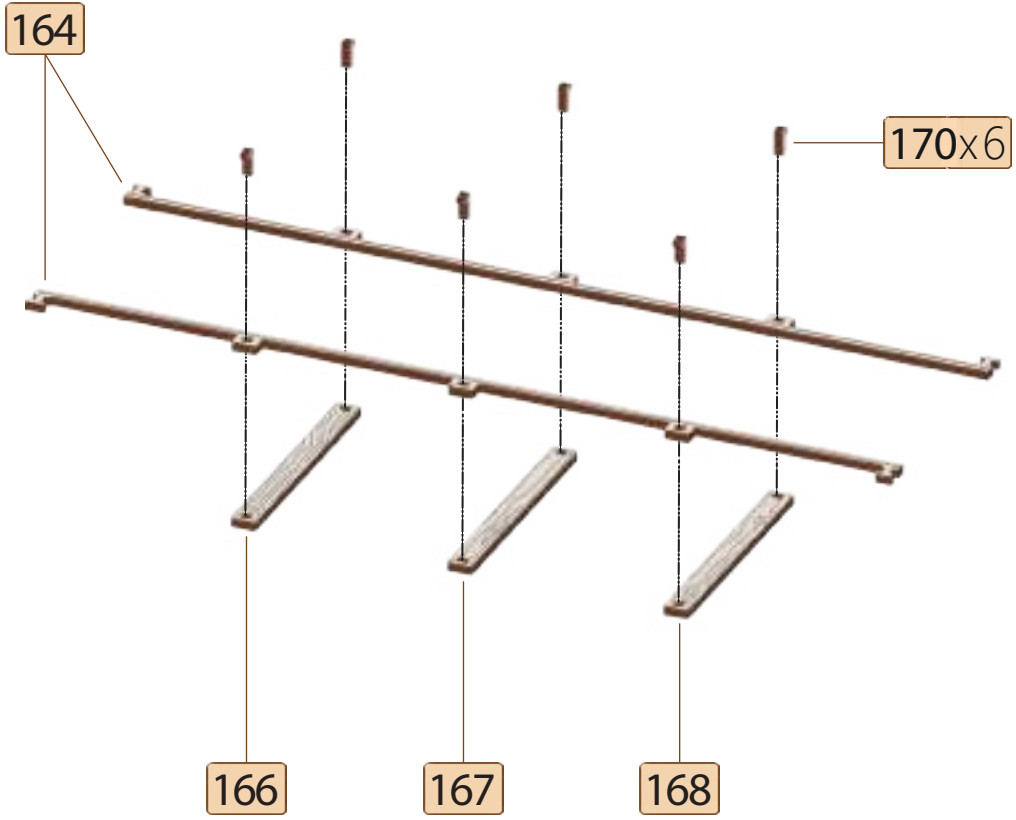
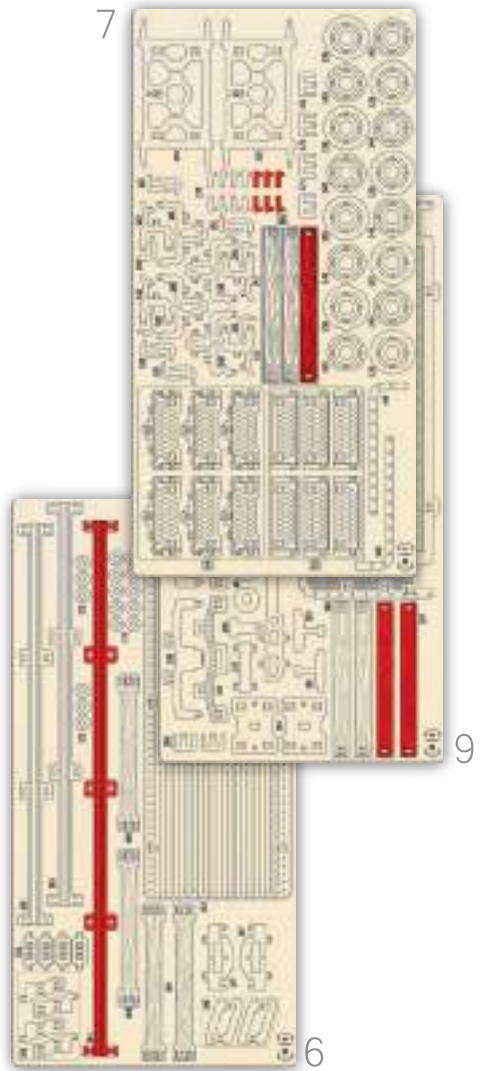

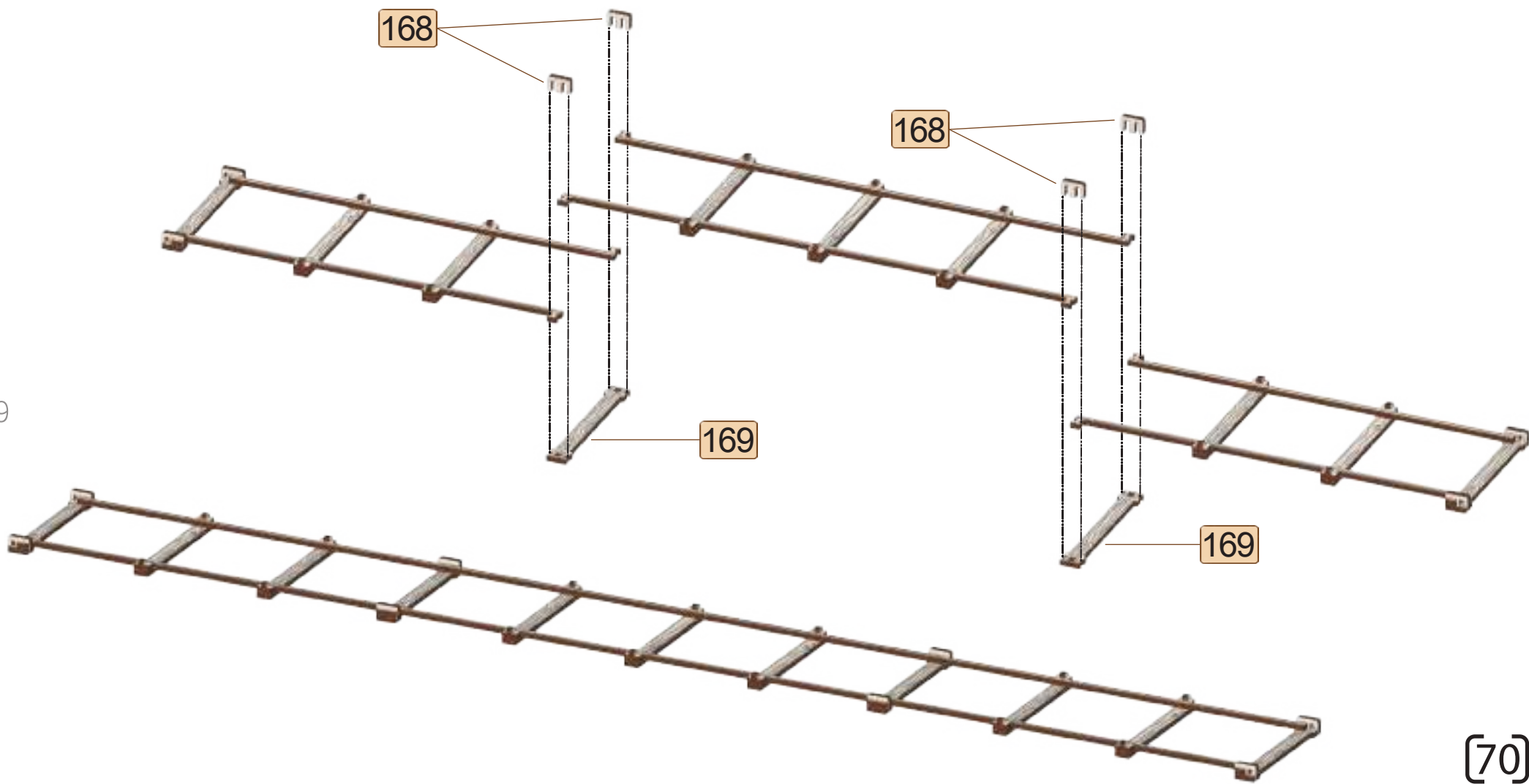
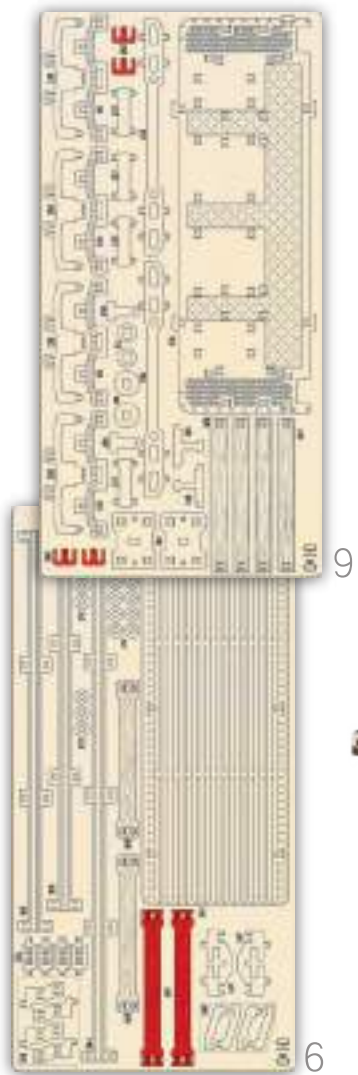

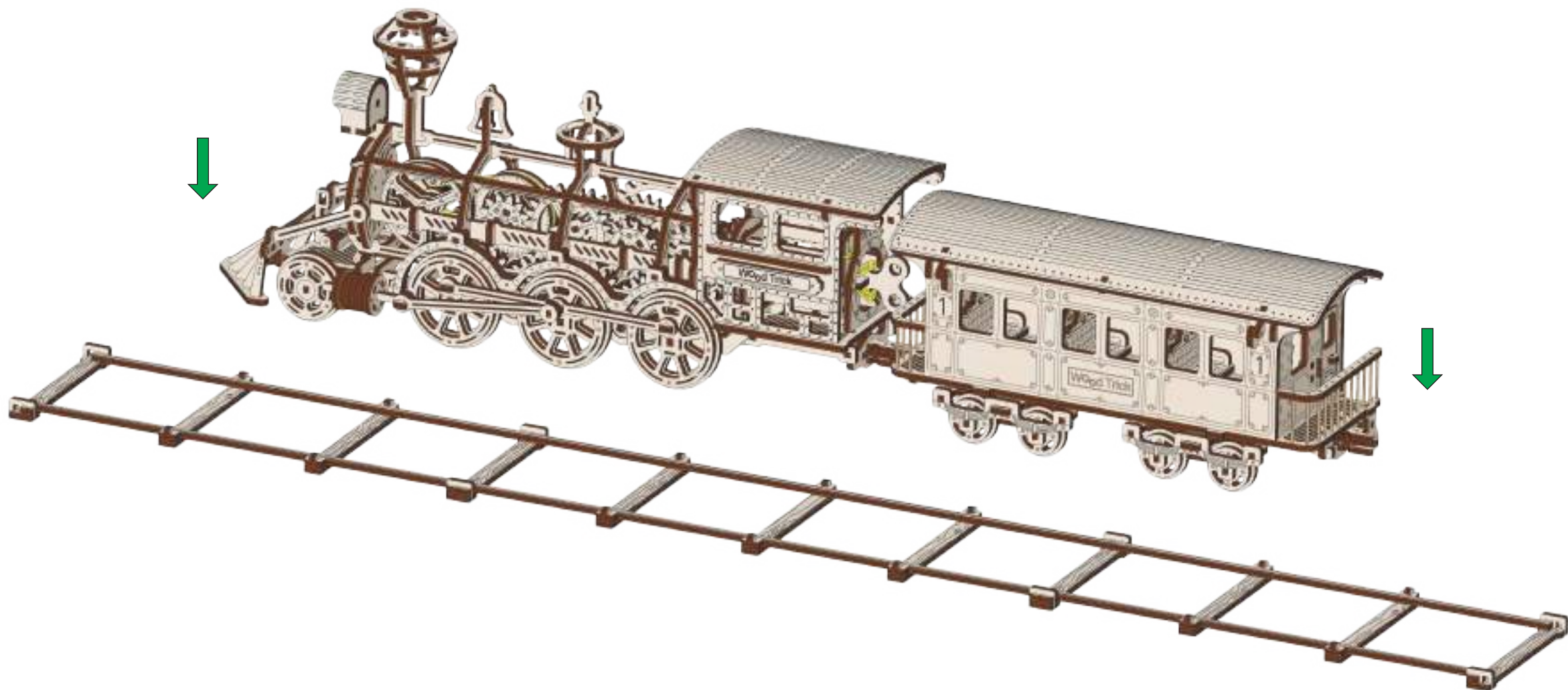



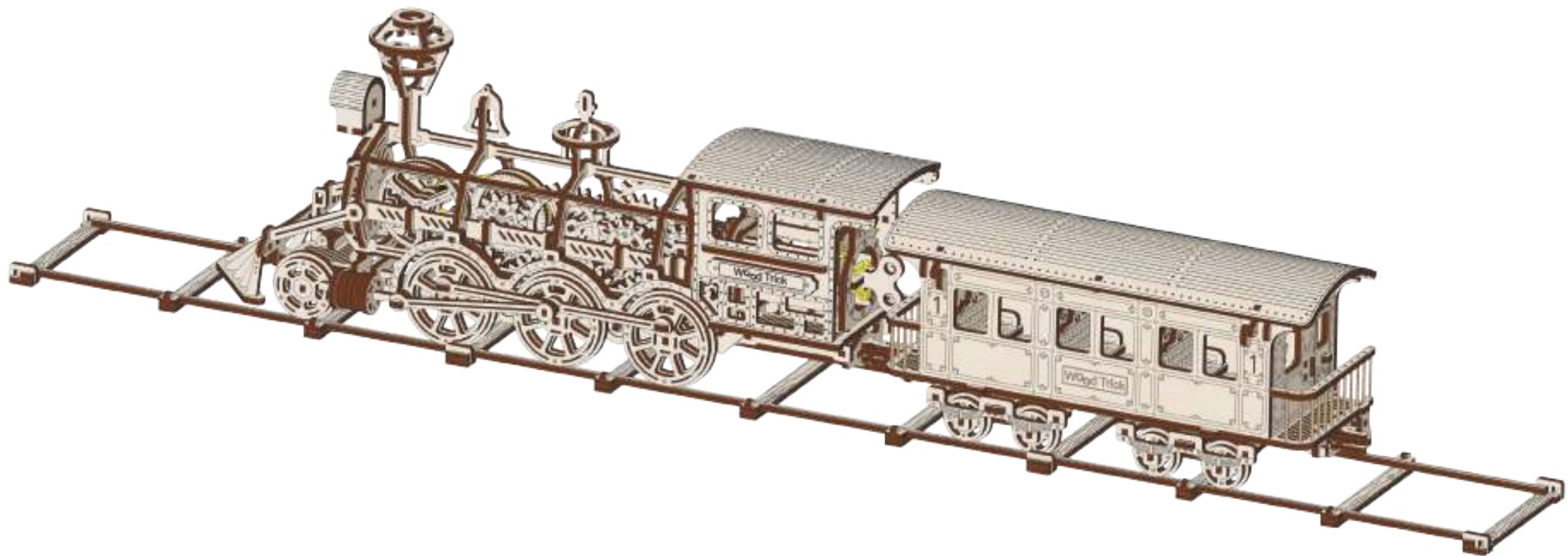

x30

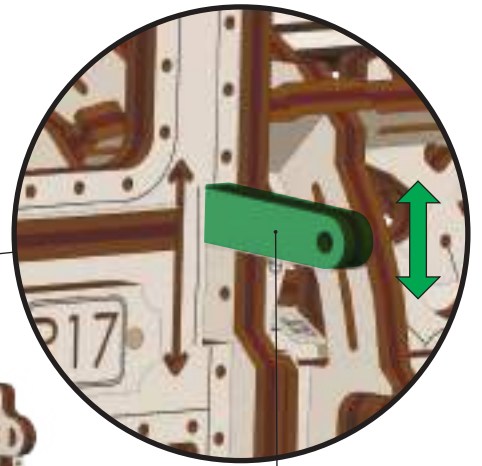
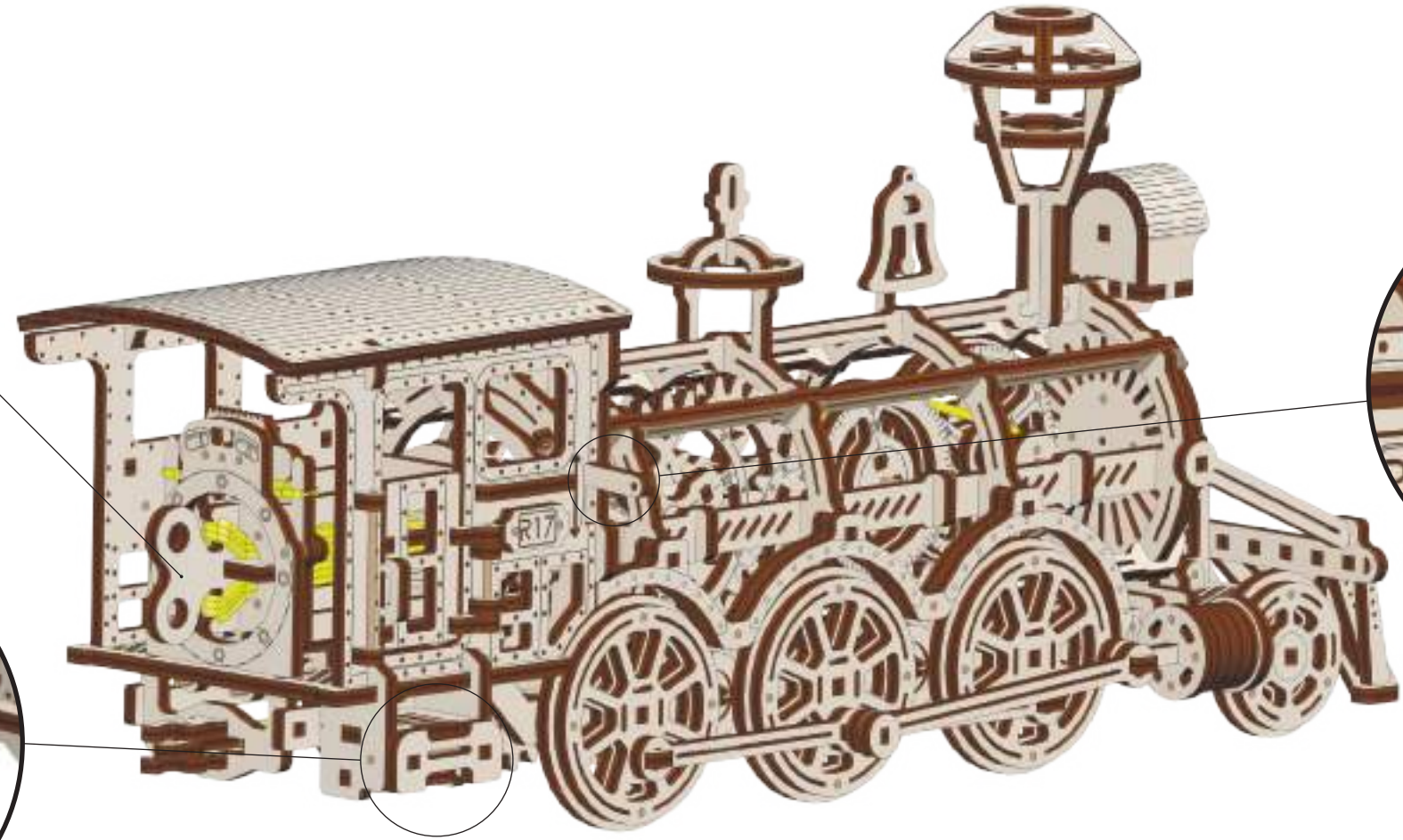
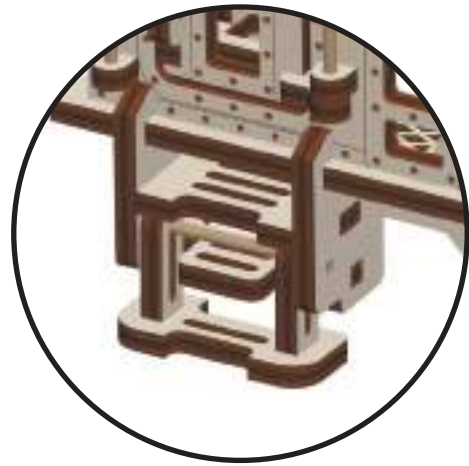

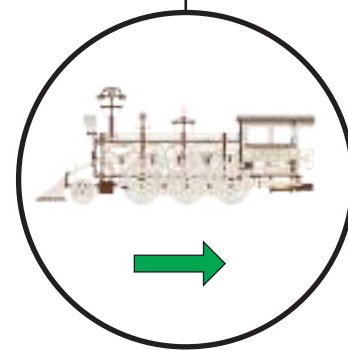
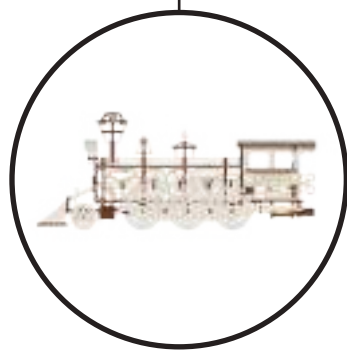
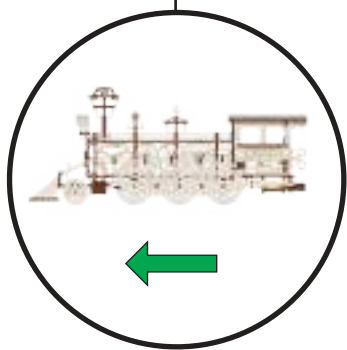
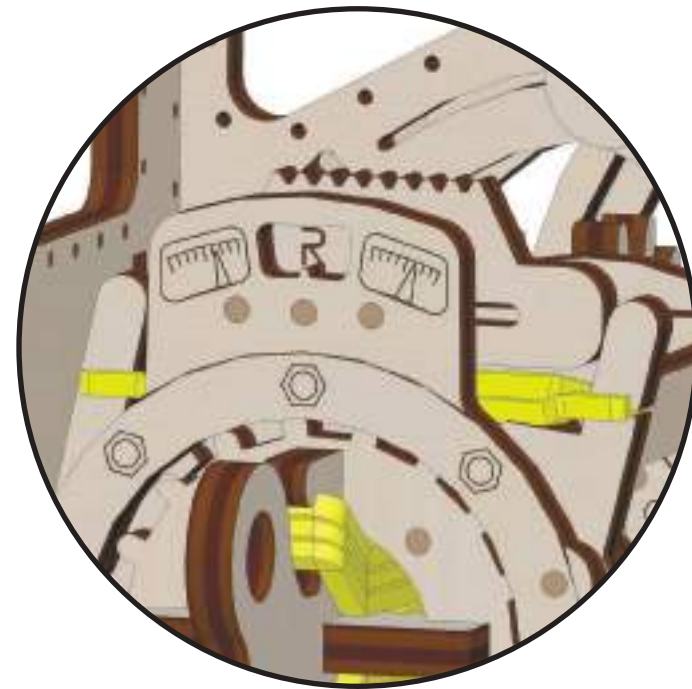
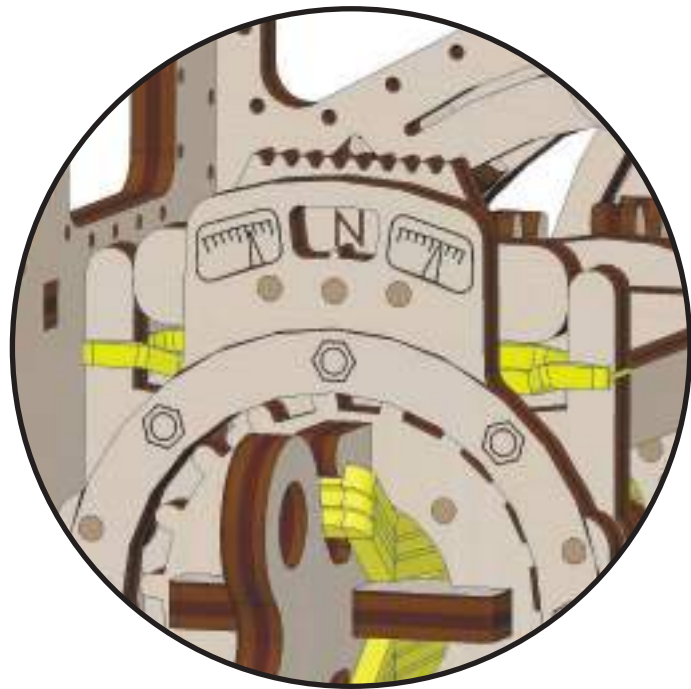
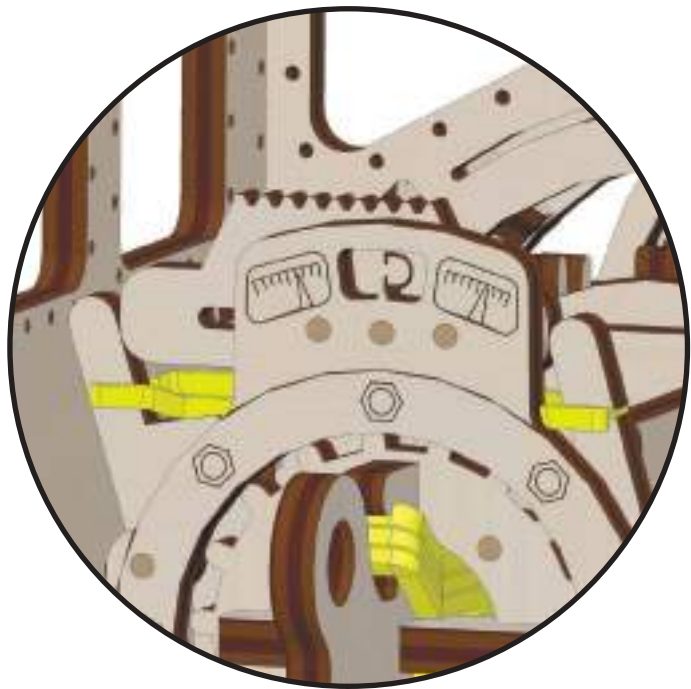



# HOW TO REPLACE A BROKEN PART

Sometimes it happens that a part of the WoodTrick model is lost or damaged.

But you have nothing to worry about because we have the replacement service. This option is free and quick, and you can easily use it for missed or damaged parts of your WoodTrick constructor.

## MAKE THE REPLACEMENT IN 5 SIMPLE STEPS

### STEP 1

Open the Replacement form on our website [woodtrick.com](https://www.woodtrick.com).

Or you can scan the QR code, which will redirect you to the replacement page.



### STEP 2

Indicate the reason for replacement.

There is no need to attach the photo or video of the broken part, it's enough to choose the reason in the list.

### STEP 3

Mention the name or the set number of the WoodTrick model with the missing part.

Name: LOCOMOTIVE R-17  
Set number: WDTK022

### STEP 4

Choose the board\* which contains the part you need.

\*All parts and all boards have the numbers. For the replacement you'll need to mention the № of the board. To find the correct board, use the assembly instruction.

### STEP 5

Fill the delivery address and it's done!

### FREE REPLACEMENT

For each WoodTrick model we provide 2 (two) free replacements. We always send the full board to avoid the risks of damaging a small part during the delivery. For example, if you need part 14 which belongs to Board 1, we will send the whole Board 1.

### NEED SOME HELP?

In case you faced any difficulties with the replacement please contact us: [support@woodtrick.com](mailto:support@woodtrick.com). Our support team is available 24/7 and will assist with the issue. You can also get the consultation from support for any questions about assembly.