

# WOOD TRIK

ENGINEERING  
J00000000004

SPECIAL  
FORCES  
SERIES



MECHANICAL MODELS & KITS  
**DEFENDERS  
GUN**

○○○○○  
2 LEVEL  
**256**  
PIECES

WDTK063

# WOD TRICK

**UKR** Увага! **ENG** Attention! **DEU** Achtung! Attention! **POL** Uwaga!  
**SPA** Atención! **ITA** Attenzione!



**UKR** Не підпалювати! **ENG** Do not set fire to it! **DEU** Nicht anzünden! **FRA** Ne pas allumer!  
**POL** nie podpalaj! **SPA** No prender fuego! **ITA** Non dare fuoco!



**UKR** Обережно! Гострі деталі! **ENG** Caution! Sharp parts! **DEU** Vorsichtig! Scharfe Details!  
**FRA** Attention Détails tranchants! **POL** Uwaga! Ostre szczegóły! **SPA** Cuidado! Piezas cortantes!  
**ITA** Attenzione! Dettagli nitidi!

**UKR** Рекомендація: якщо виникли складнощі при скріпленні деталей, обробіть зубочистки парафіном. **ENG** Recommendation: if you have difficulty in connecting parts, treat toothpicks with paraffin. **DEU** Empfehlung: Wenn Sie Schwierigkeiten haben, Teile zu verbinden, behandeln Sie Zahnstocher mit Paraffin. **FRA** Recommendation: si vous avez des difficultés pièces de fixation, traitez les cure-dents avec de la paraffine. **POL** Zalecenie: jeśli masz trudności z połączeniem części, obsługiwać wykałaczki parafiną. **SPA** Recomendación: si tiene dificultades para fijar piezas, trate mondadientes con parafina. **ITA** Raccomandazione: in caso di difficoltà nel fissare le parti, trattare gli stuzzicadenti con paraffina.

**UKR** Конструктор не вимагає застосування клею. **ENG** The assembling of constructor does not require to use glue. **DEU** Für die Montage des Konstruktors ist kein Klebstoff erforderlich. **FRA** Aucune colle n'est nécessaire pour monter le constructeur. **POL** Montaż konstruktora odbywa się bez kleju. **SPA** El montaje constructor no requiere el uso de pegamento. **ITA** L'assemblaggio non richiede l'uso di colla.

**UKR** Крихкі деталі! Під час вилучення конструктора з карти будьте обережні! **ENG** Fragile details! Be careful when removing the constructor from the card! **DEU** Zerbrechliche Details! Seien Sie vorsichtig, wenn Sie den Konstruktor von der Karte entfernen! **FRA** Détails fragiles! Faites attention en retirant les éléments de la construction de la carte! **POL** Krucho szczegóły! Przedmioty należy wyjmować z karty ostrożnie! **SPA** Detalles frágiles! Sea prudente al sacar elementos de mecano del tarjeta! **ITA** Dettagli fragili! Gli elementi vanno estratti dalla scheda con cautela!

**UKR** Всі елементи, що входять у зачеплення необхідно зачистити наждачним папером і змастити парафіном. **ENG** All elements that interlock must be sanded with sandpaper and greased with paraffin. **DEU** Alle eingreifenden Teile müssen mit Sandpapier gereinigt und mit Paraffin eingefettet werden. **FRA** Il faut nettoyer tous les éléments de l'accrochage à l'aide du papier-meri et les traiter avec de la paraffine. **POL** Wszystkie zaczepione elementy należy oczyścić papierem ściernym i nasmarować parafiną. **SPA** Todos los elementos que se enganchan deben limpiarse con papel de lija y engrasarse con parafina. **ITA** Tutti gli elementi agganciati devono essere puliti con carta vetrata e ingrassati con paraffina.

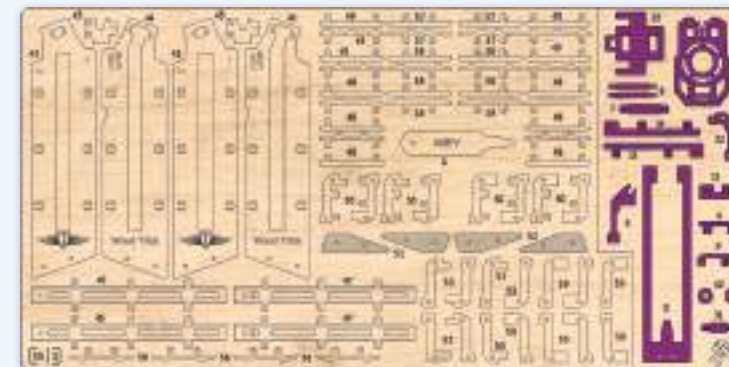
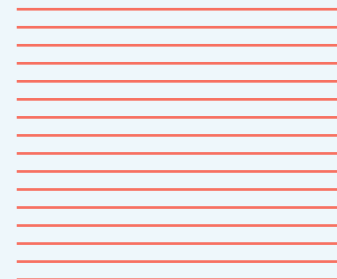

**UKR** Запасні деталі. **ENG** Spare parts. **DEU** Ersatzteile. **FRA** Pièces de rechange. **POL** Części zamienne. **SPA** Repuestos. **ITA** Pezzi di ricambio.

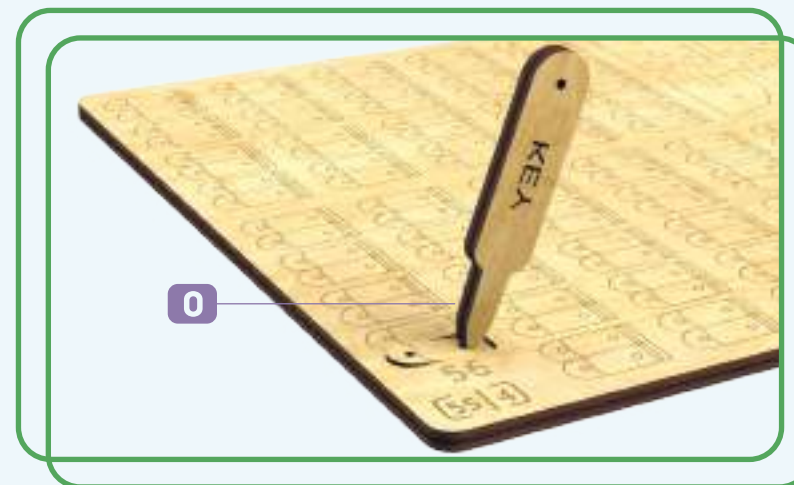

**UKR** Допоміжний інструмент для збірки або вимірювання відстаней. **ENG** Auxiliary tool for assembling or measuring distances. **DEU** Hilfswerkzeug zum Montieren oder Messen von Abständen. **FRA** Outil auxiliaire pour assembler ou mesurer des distances. **POL** Narzędzie pomocnicze do montażu lub pomiaru odległości. **SPA** Herramienta auxiliar para ensamblar o medir distancias. **ITA** Strumento ausiliario per l'assemblaggio o la misurazione delle distanze.



**UKR** Відрізати зубочистку. **ENG** Cut off a toothpick. **DEU** Schneiden Sie einen Zahnstocher ab. **FRA** Couper la cure-dent. **POL** Odetnij wykałaczkę. **SPA** Cortar un palillo de dientes. **ITA** Tagliare lo stecchino.



**UKR** Обламати з двох сторін. **ENG** Break off from both sides. **DEU** Brechen Sie einen Zahnstocher auf beiden Seiten ab. **FRA** Casser un cure-dent des deux côtés. **POL** Oblomaj wykałaczkę po obu stronach. **SPA** Romper un palillo de dientes en ambos lados. **ITA** Rompere uno stecchino su entrambi i lati.



**UKR** Видалити задирки. **ENG** Remove burrs. **DEU** Niednägel entfernen. **FRA** Enlever les bavures. **POL** Usuń zadziory. **SPA** Quitar rebabas. **ITA** Eliminare le bave.



**UKR** Деталь повинна вільно обертатися. **ENG** The part must. **DEU** Das detail muss sich frei drehen. **FRA** L'élément doit tourner librement. **POL** Część powinna swobodnie obracać się. **SPA** La pieza debe girar libremente. **ITA** Il dettaglio deve ruotare liberamente.



**UKR** Змастити парафіном. **ENG** Lubricate with paraffin. **DEU** Mit dem Paraffin schmieren. **FRA** Lubrifier à la paraffine. **POL** Nasmaruj parafiną. **SPA** Lubricar con parafina. **ITA** Lubrificare con paraffina.

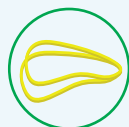

**UKR** Необхідно скрутити резинку вдвічі. **ENG** It is necessary to twist the rubber band twice. **DEU** Man muss das Gummiband zweifach drehen. **FRA** Il faut tordre la gomme élastique en deux. **POL** Należy skręcić gumę o połowę. **SPA** Es necesario torcer la goma dos veces. **ITA** E' necessario torcere la gomma in due.



**UKR** Конструктор може в деяких місцях туго з'єднатися, для того, щоб зібрана модель мала міцність та надійність. Для більш зручної збірки конструктора, рекомендуємо використовувати плоскогубці та канцелярський ніж. **ENG** Design kit can be tightly connected in some places, so that the assembled model has solidity and reliability. We recommend using pliers and box cutter for a more convenient design kit assembly. **DEU** Der Konstruktor kann an einigen Stellen keine gute Verbindung herstellen, so daß das zusammengebaute Modell eine ausreichende Festigkeit und Zuverlässigkeit aufweist. Für eine bequemere Montage des Konstrukteurs empfehlen wir die Verwendung einer Zange und eines Schreibwarenmessers. **FRA** Le jeu de construction peut être étroitement connecté à certains endroits, pour que le modèle assemblé soit solide et fiable. Pour un assemblage plus pratique de jeu de construction, nous vous recommandons d'utiliser une pince et un couteau à papeterie. **ITA** Le jeu de construction peut être étroitement connecté à certains endroits, pour que le modèle assemblé soit solide et fiable. Pour un assemblage plus pratique de jeu de construction, nous vous recommandons d'utiliser une pince et un couteau à papeterie. **POL** Le jeu de construction peut être étroitement connecté à certains endroits, pour que le modèle assemblé soit solide et fiable. Pour un assemblage plus pratique de jeu de construction, nous vous recommandons d'utiliser une pince et un couteau à papeterie.

**UKR** Увага! Для коректної роботи даної моделі, необхідно при збірці ретельно зачищати, змащувати парафіном усі деталі, які труться. Усі механізми повинні вільно обертатися. **ENG** Warning! For the correct operation of this model, it is necessary to clean carefully and to lubricate all rubbing parts with paraffin during assembly. All mechanisms must rotate freely. **FRA** Attention! Pour le bon fonctionnement de ce modèle, il est nécessaire lors du montage de nettoyer et lubrifier soigneusement toutes les pièces à friction avec de la paraffine. Tous les mécanismes doivent tourner librement. **SPA** ¡Atención! Para el funcionamiento adecuado de este modelo a la hora de ensamblaje se recomienda alisar y lubricar cuidadosamente con parafina todos los detalles frotantes. Todos los mecanismos deben girar libremente. **ITA** Attenzione! Per il corretto funzionamento di questo modello, durante il montaggio, è necessario pulire e lubrificare accuratamente tutte le parti di sfregamento con paraffina. Tutti i meccanismi devono ruotare liberamente. **DEU** Hinweis! Für einen korrekten Betrieb dieses Modells ist bei dem Zusammenbau erforderlich, alle Reibteile sorgfältig auszusmirmgeln und mit Paraffin zu schmieren. Alle Bauteile sollen sich frei drehen. **POL** Uwaga! Aby ten model działał prawidłowo, podczas montażu wszystkie detale trące muszą być dokładnie oczyszczone i nasmarowane parafiną. Wszystkie mechanizmy muszą się swobodnie obracać.



**UKR** Маленька резинка. **ENG** Little rubber band. **DEU** Kleines Gummiband. **FRA** Petit élastique. **POL** Mała guma. **SPA** De goma pequena. **ITA** Piccola gomma.



**UKR** Середня гумка. **ENG** Medium rubber band. **DEU** Mittleres Gummiband. **FRA** Moyen élastique. **POL** Średnia gumka. **SPA** Tira de goma mediana. **ITA** Gomma media.



**UKR** Велика резинка. **ENG** Large rubber band. **DEU** Großes Gummiband. **FRA** Grand élastique. **POL** Duża gumka. **SPA** Tira de goma grande. **ITA** Gomma grande.



**UKR** Обережно, крихка деталь!  
**ENG** Caution, fragile detail!  
**DEU** Vorsicht, zerbrechliches Detail!  
**FRA** Attention, détail fragile!  
**POL** Uwaga, delikatny szczegół!  
**SPA** ¡Atención, frágiles detalles!  
**ITA** Attenzione, dettaglio fragile!



**UKR** Звернути увагу!  
**ENG** Note!  
**DEU** Aufgepasst!  
**FRA** Faites attention!  
**POL** Uwaga!  
**SPA** ¡Presta atención!  
**ITA** Presta attenzione!



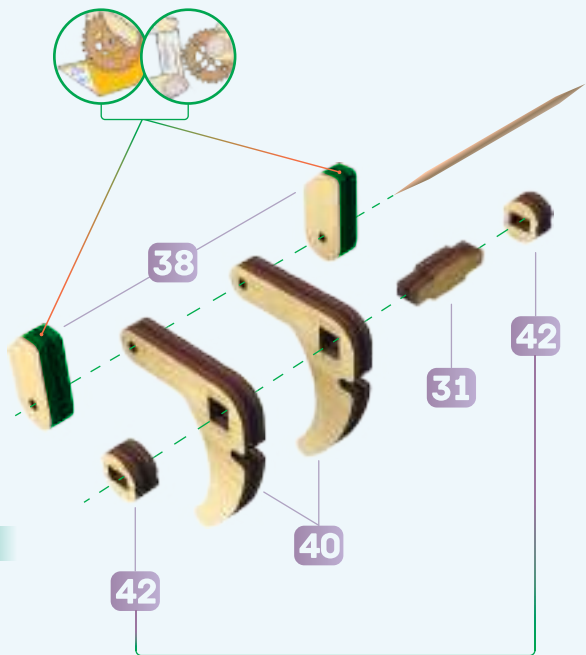
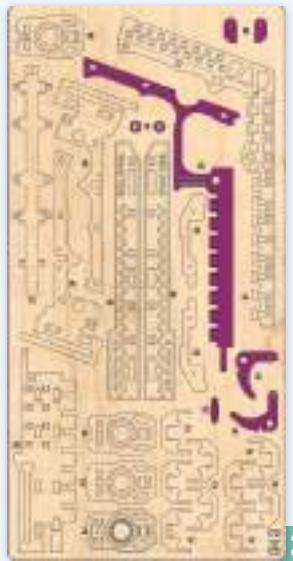

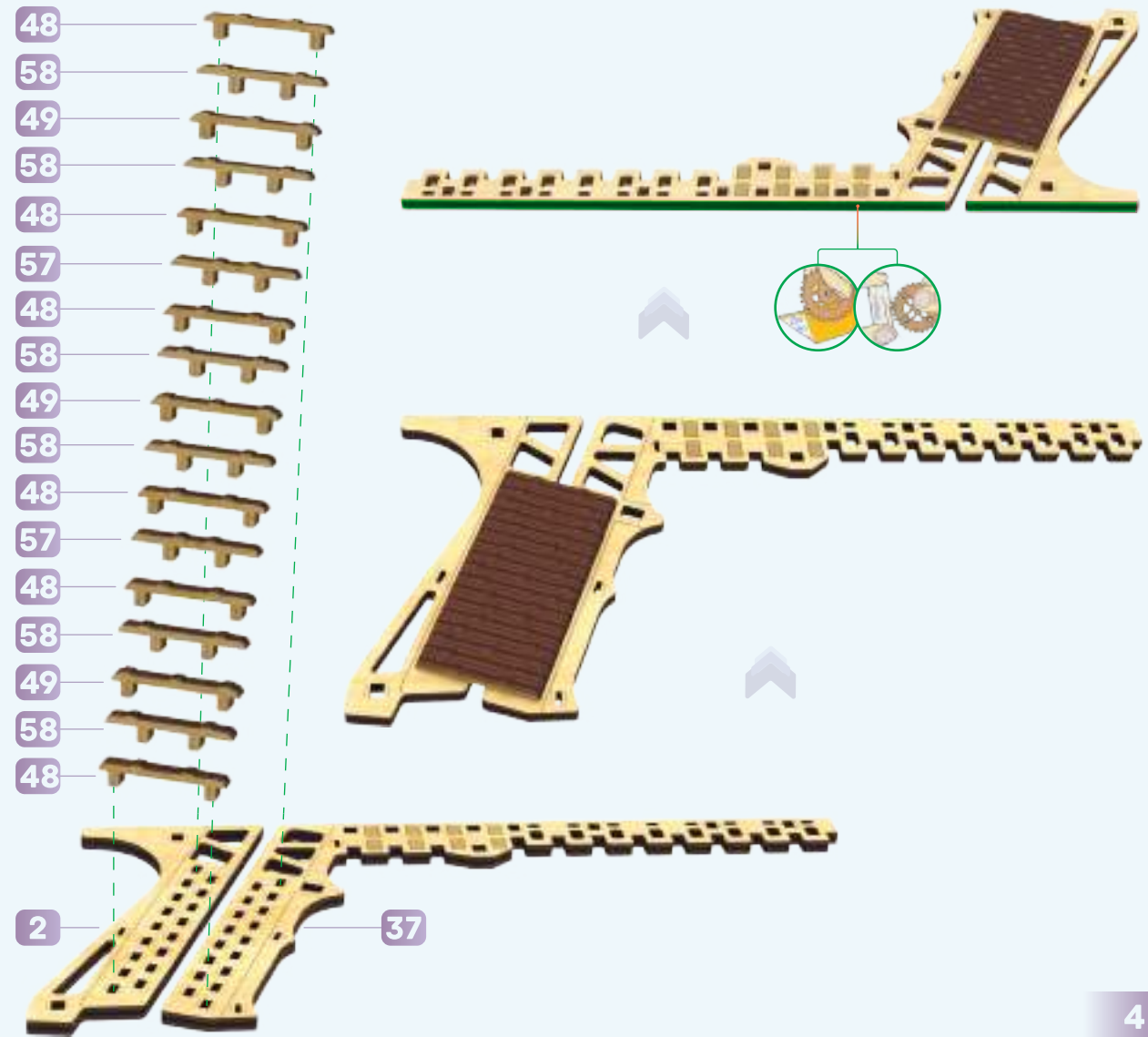
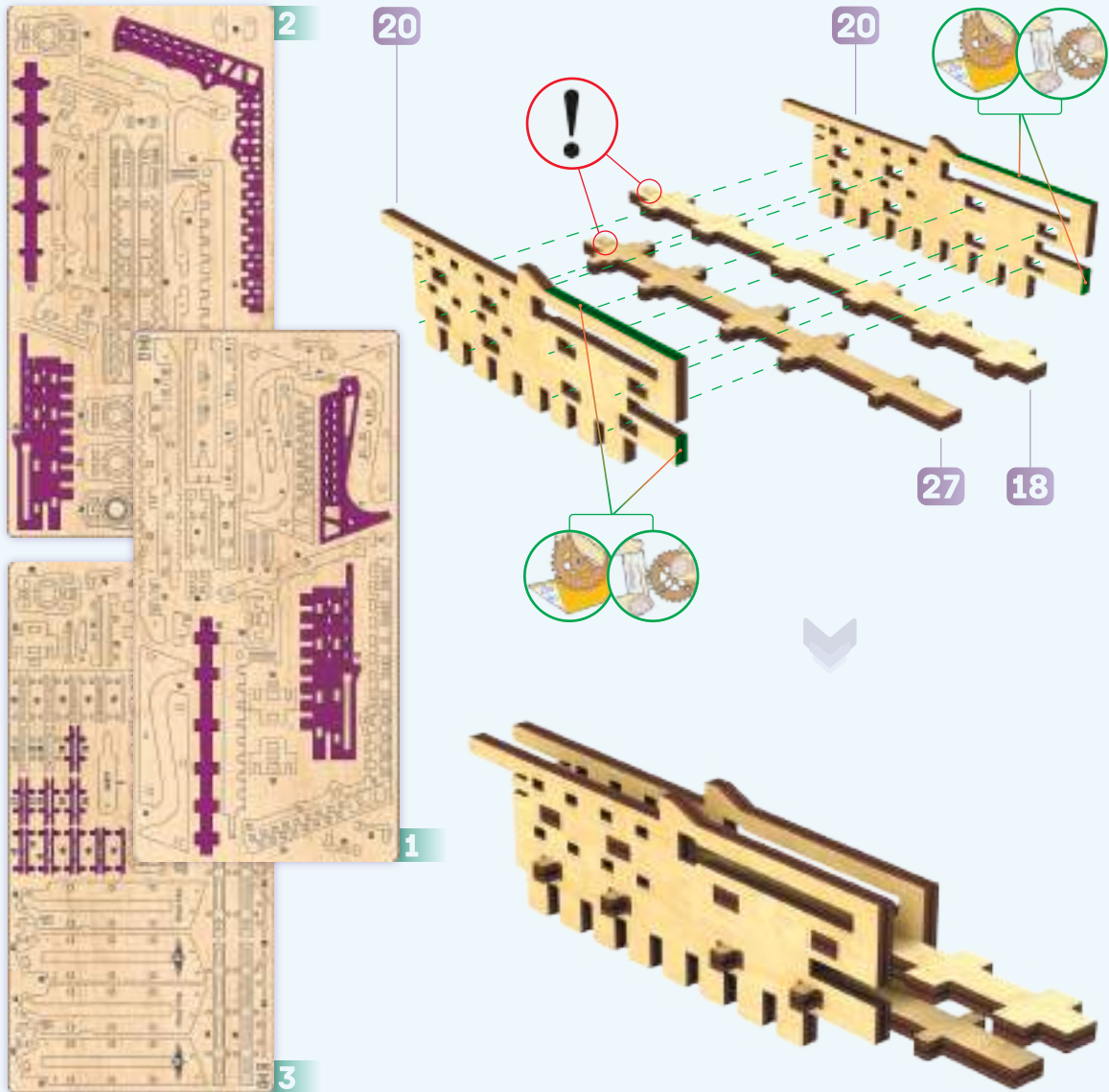

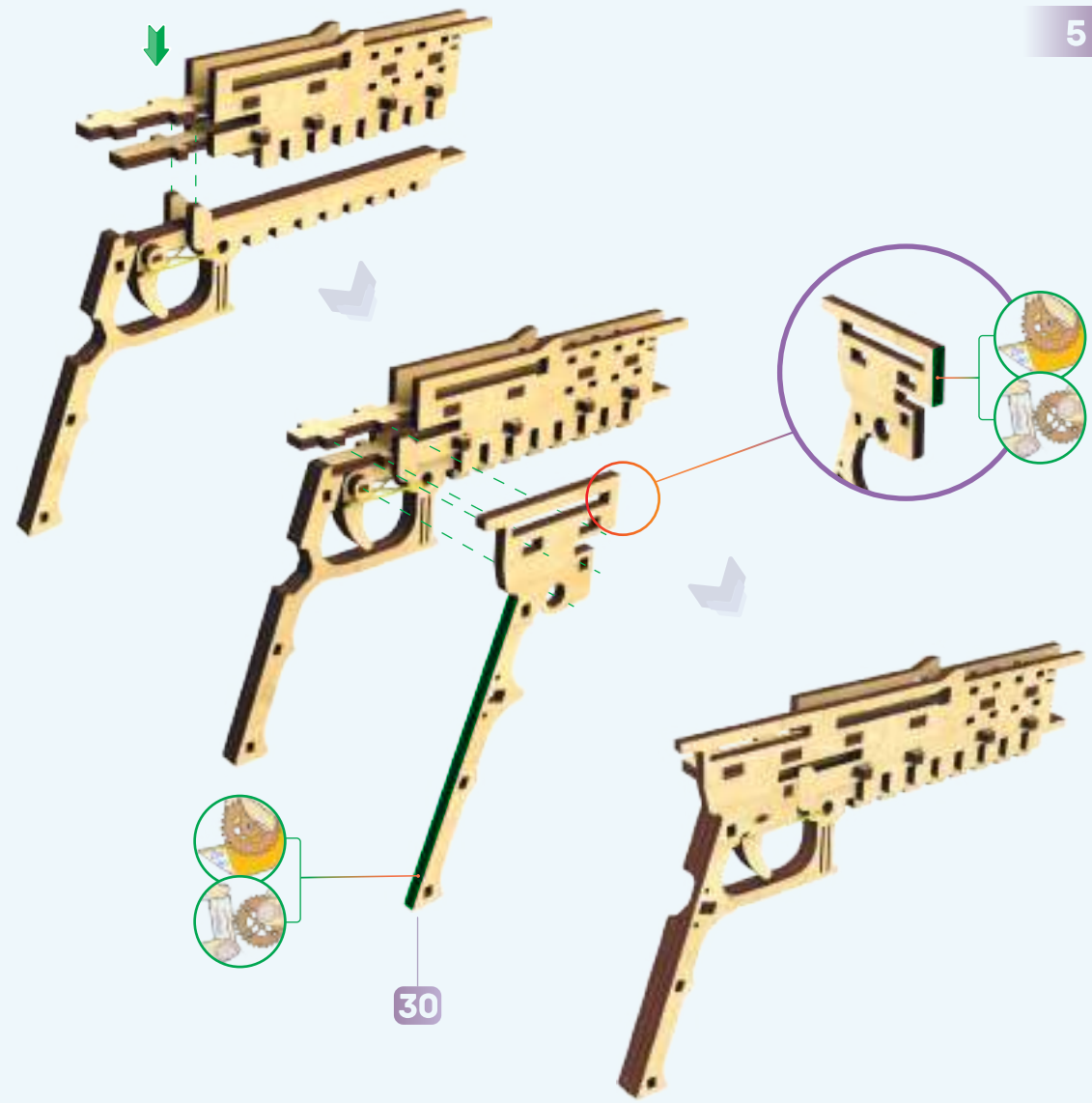
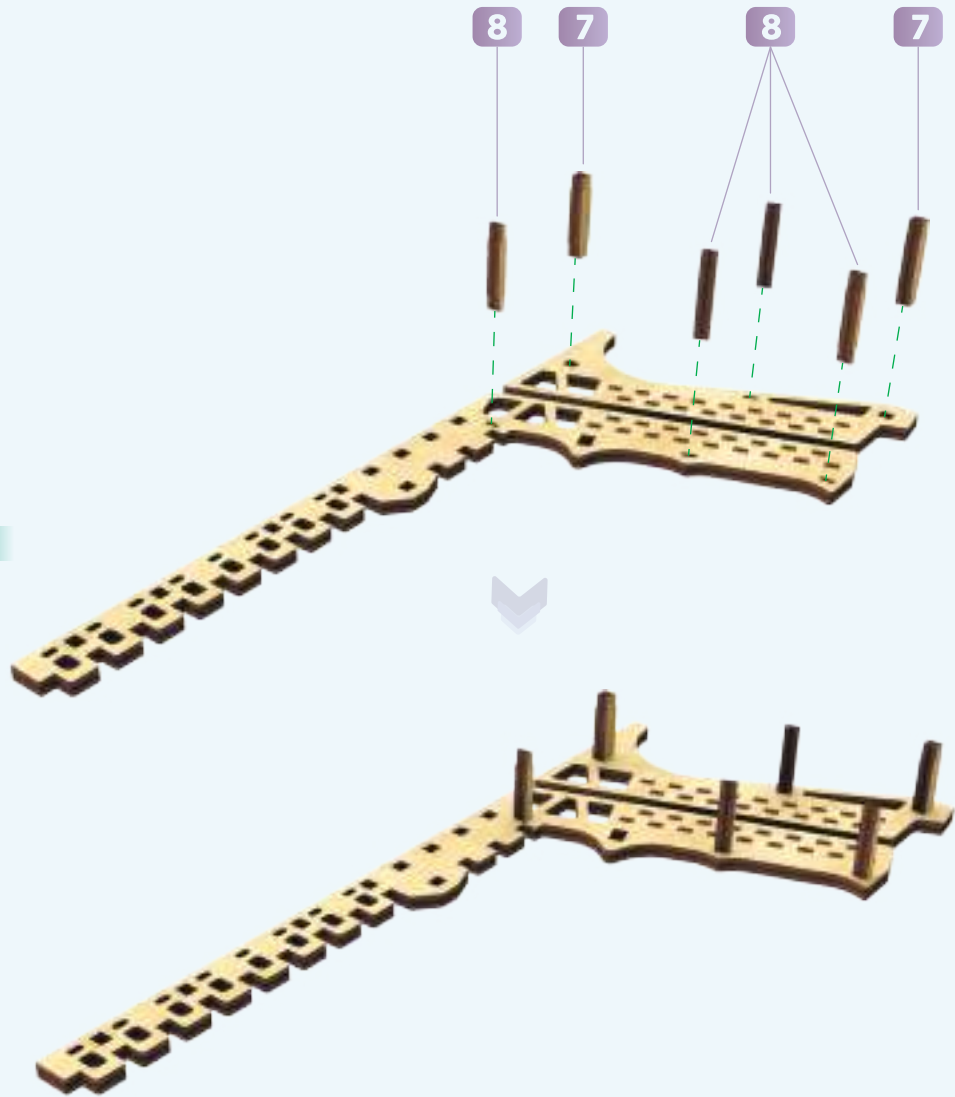



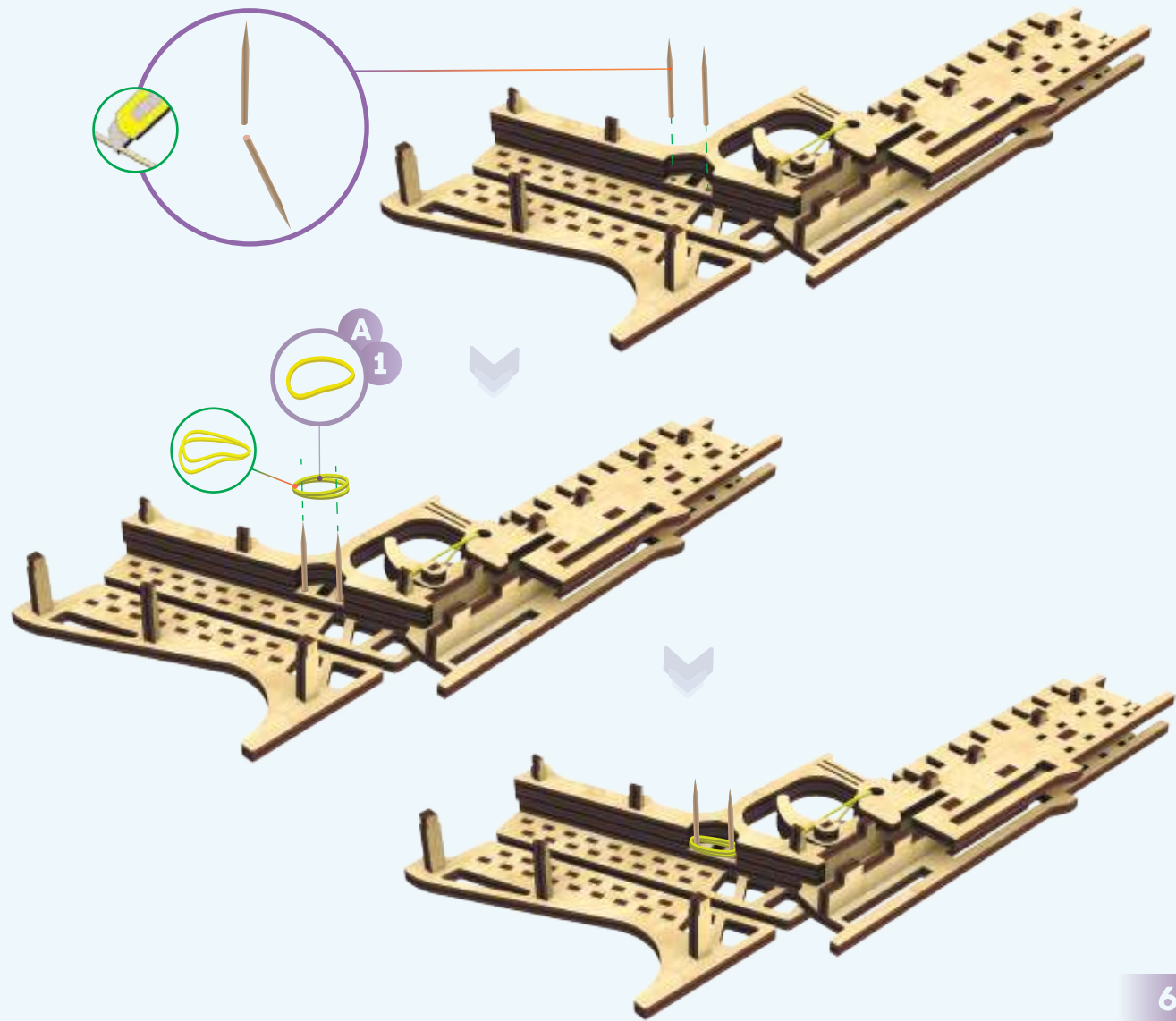
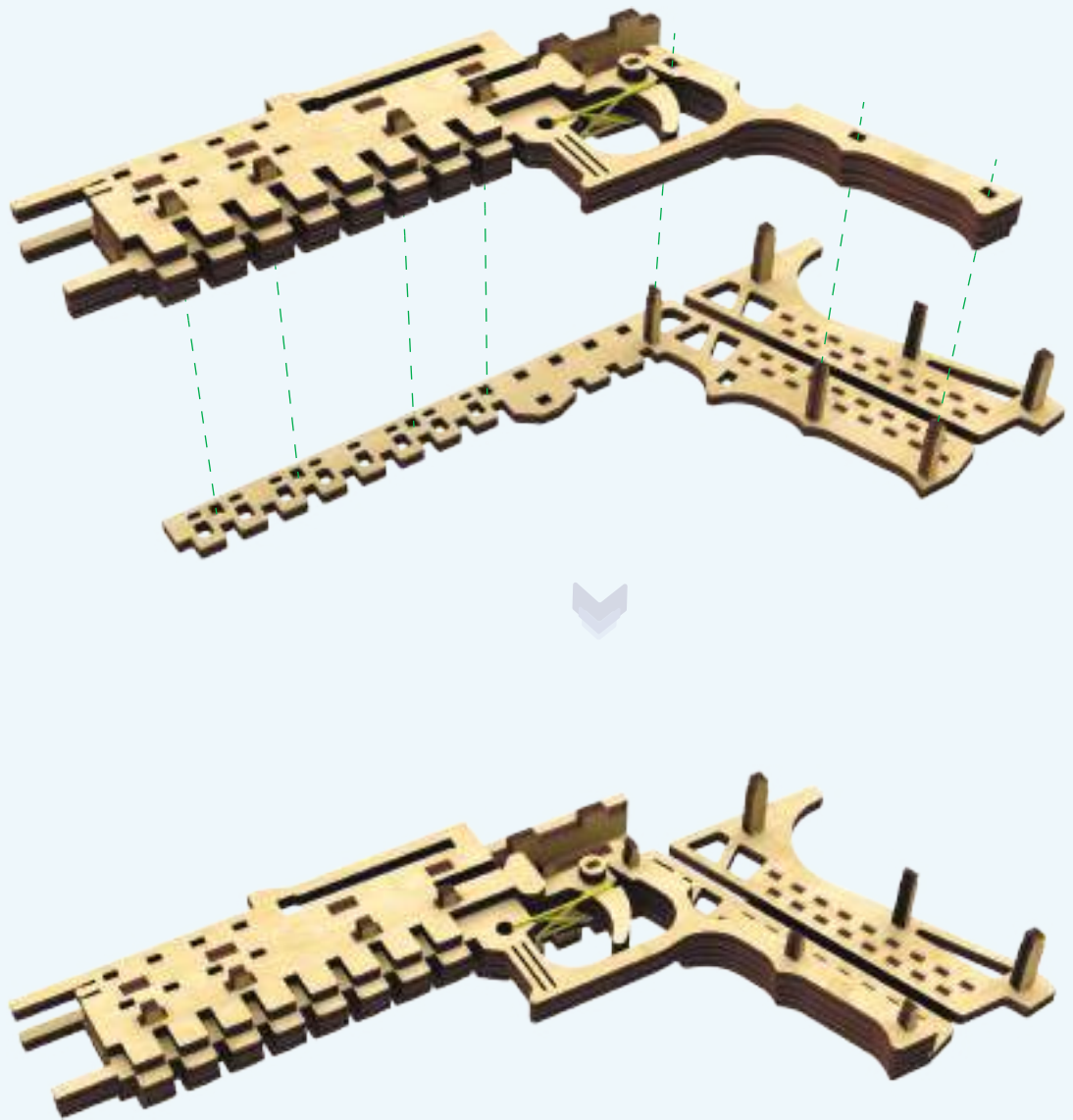

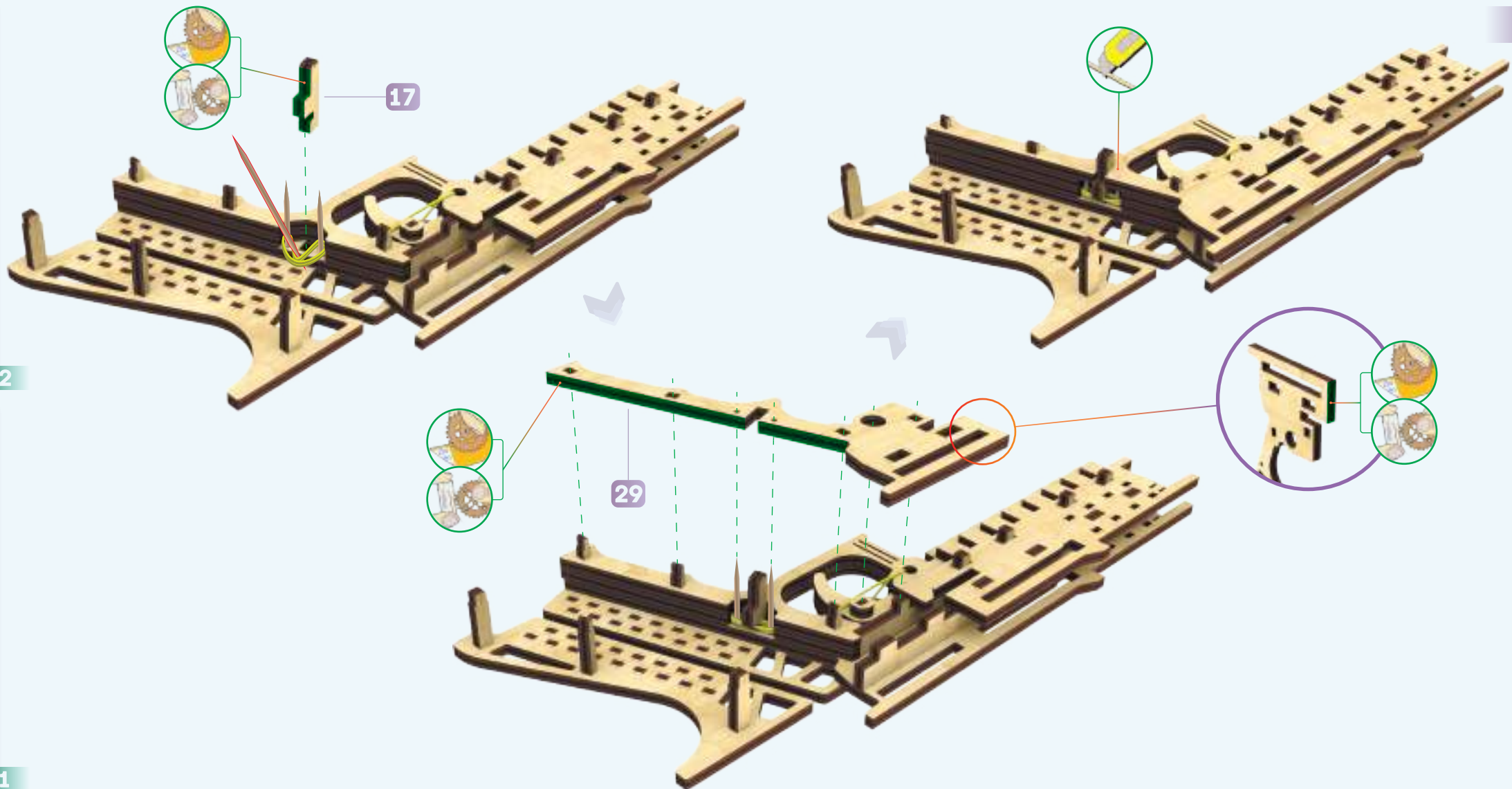



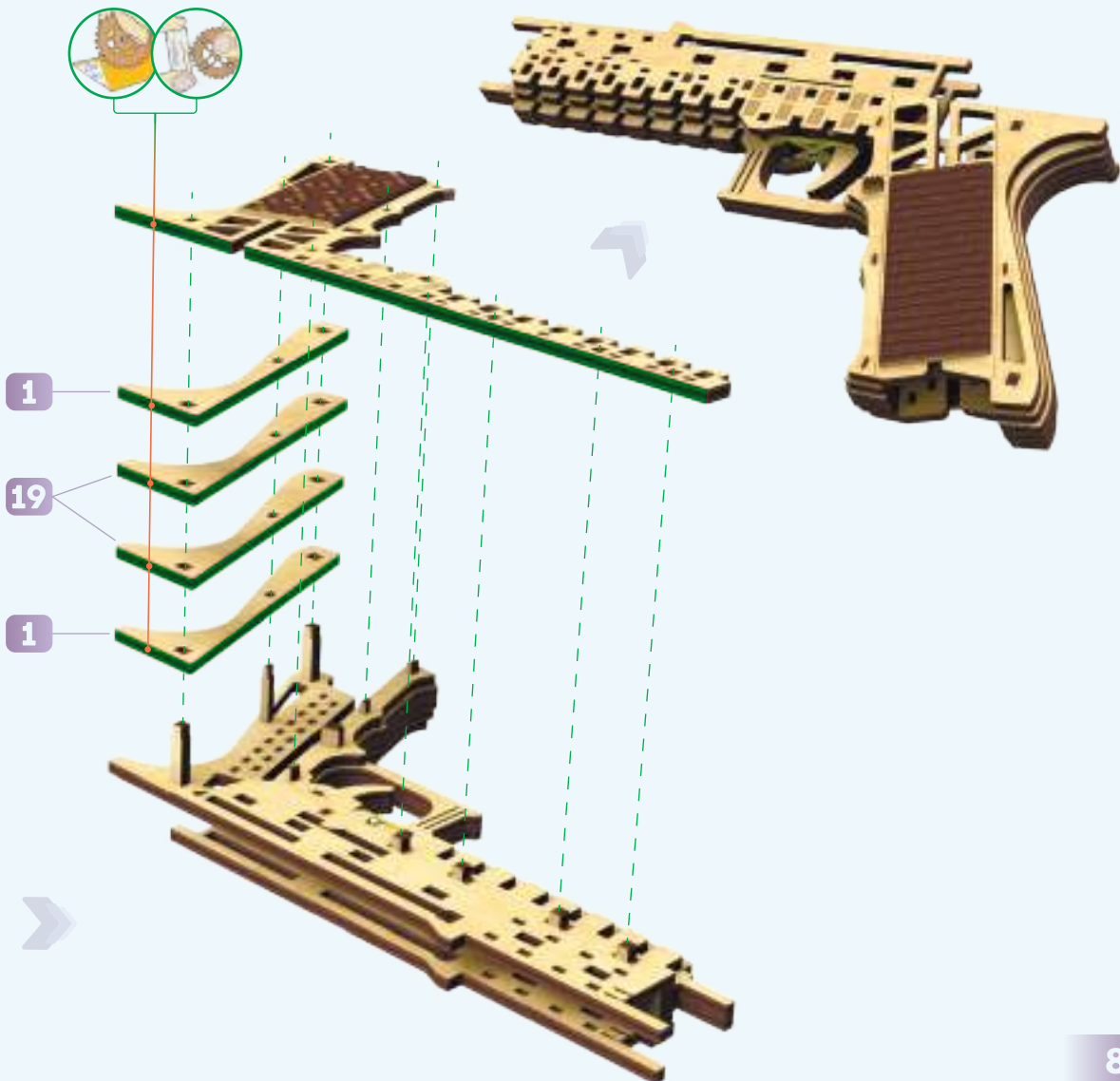
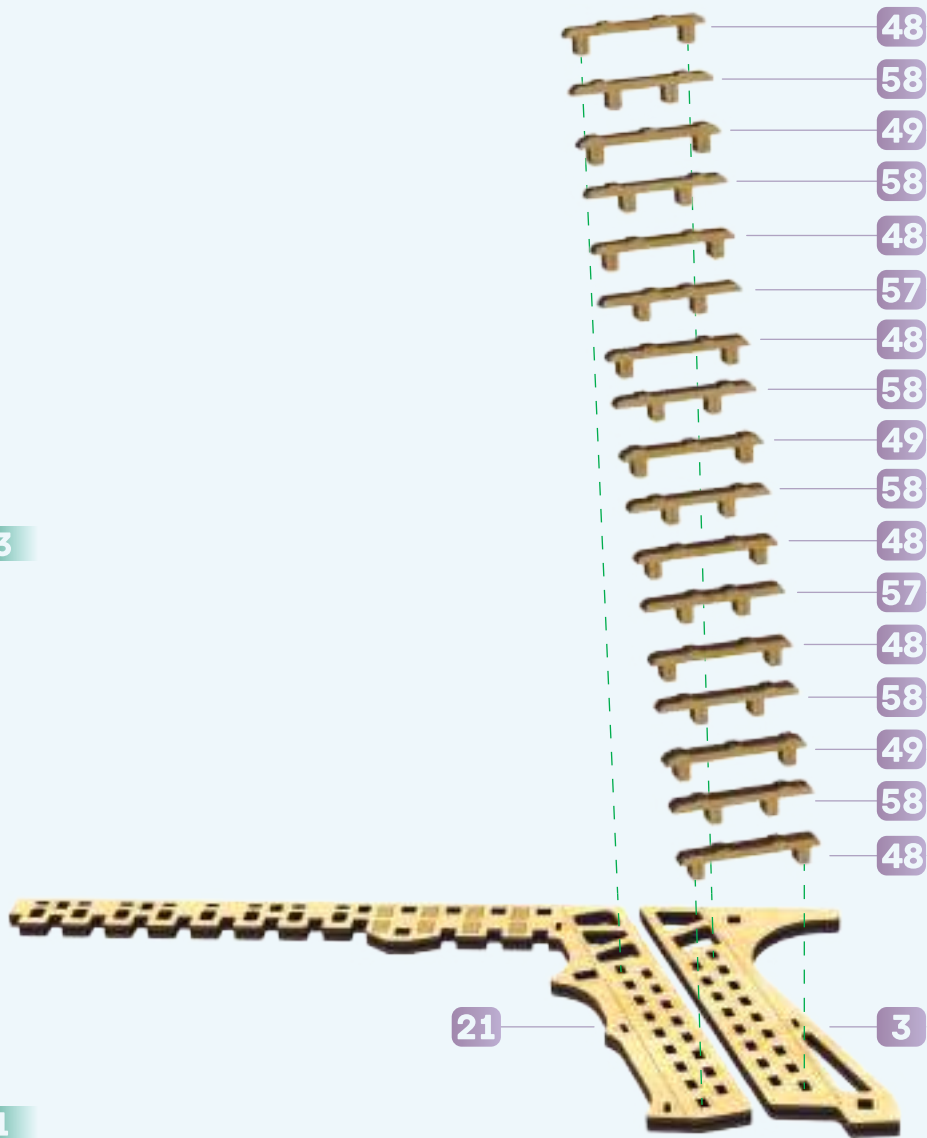
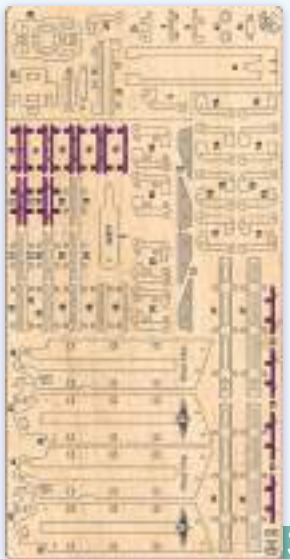

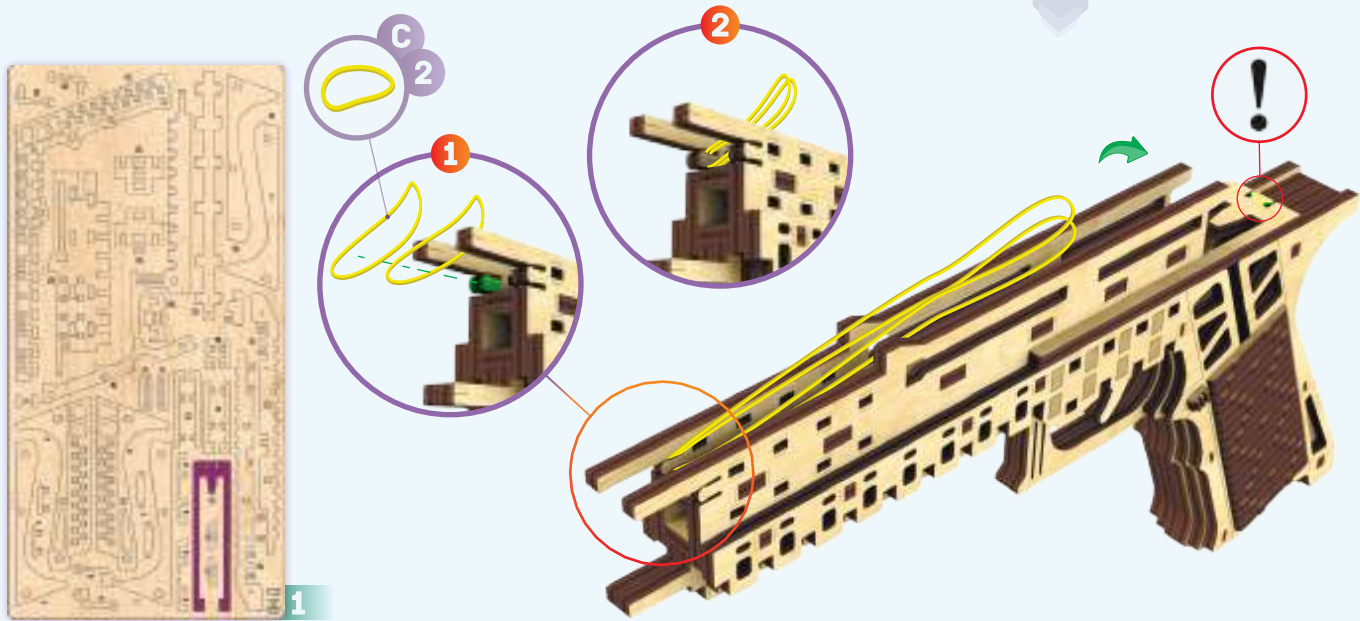
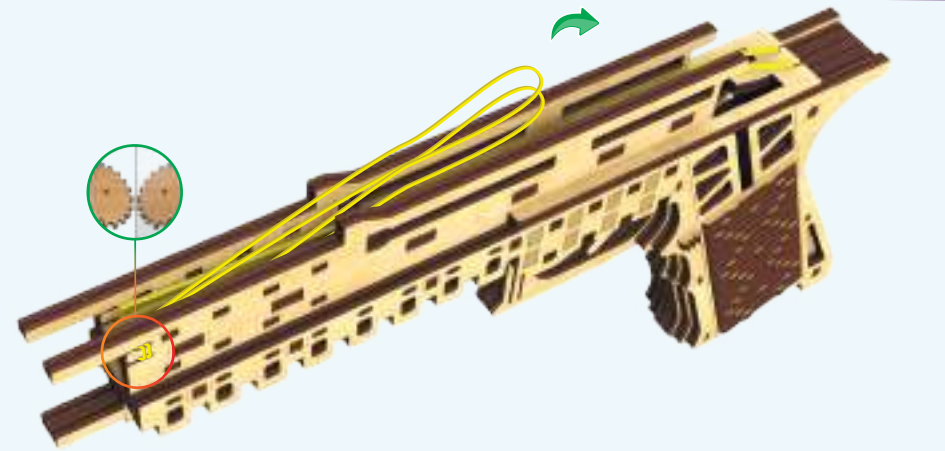
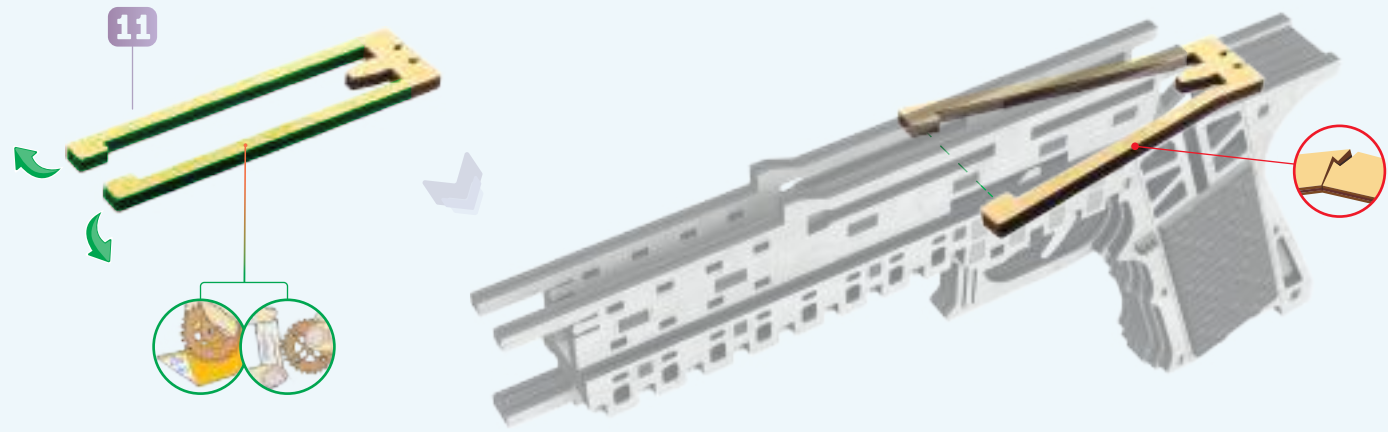





2

28

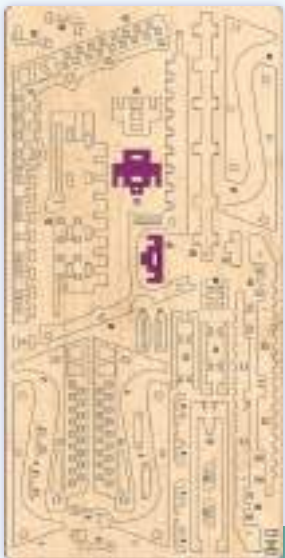
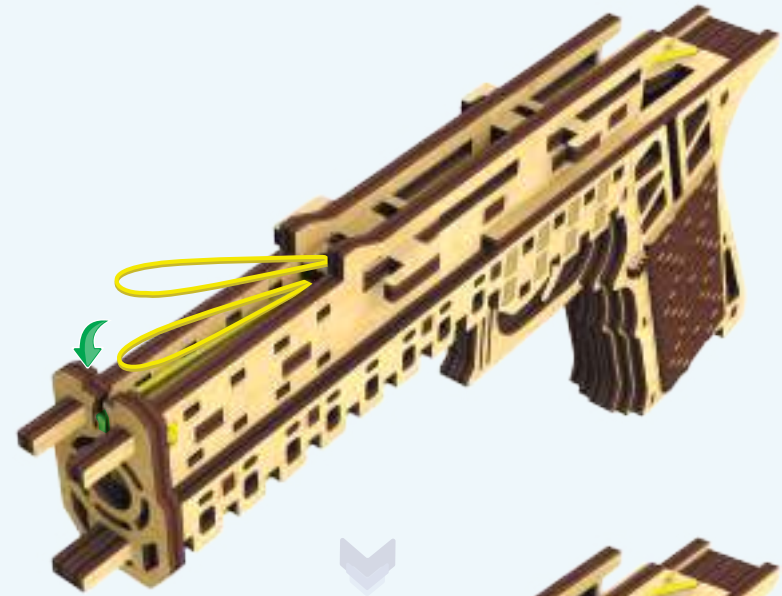

1



23

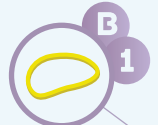

B  
1

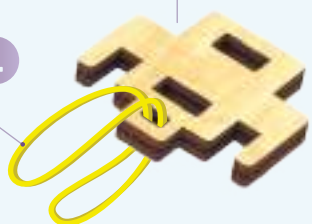

26





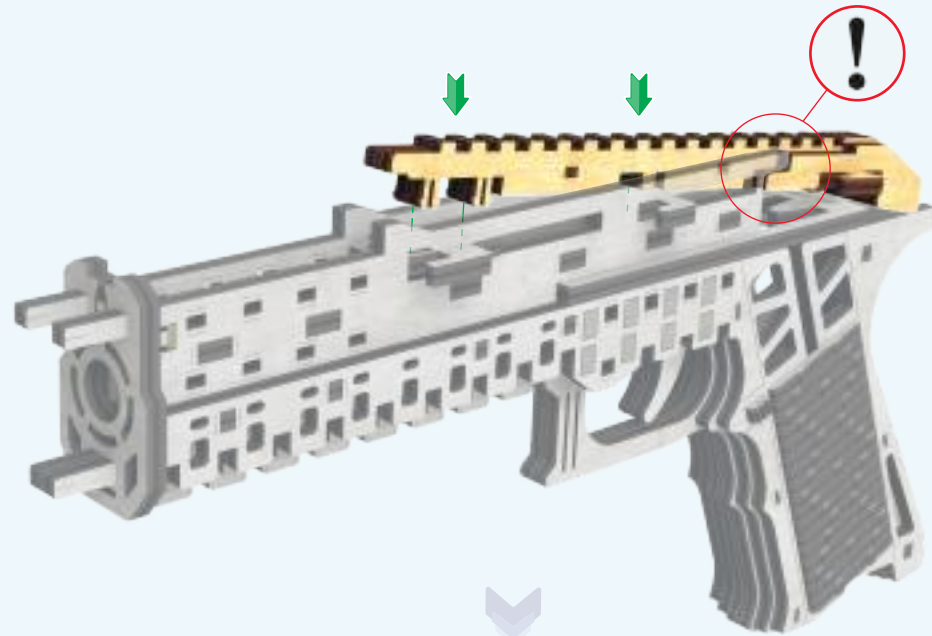
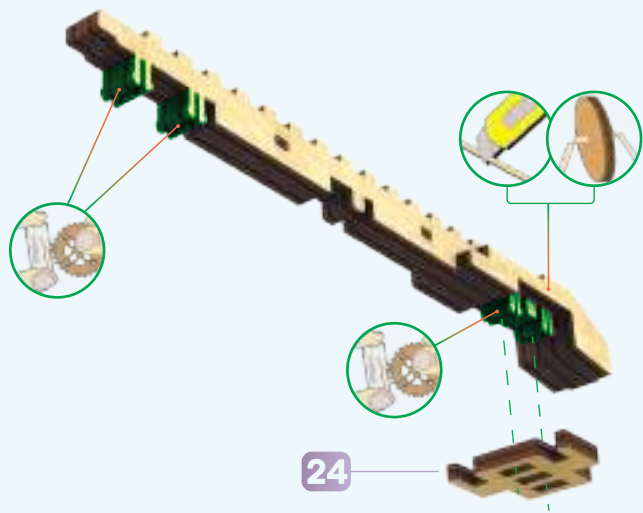
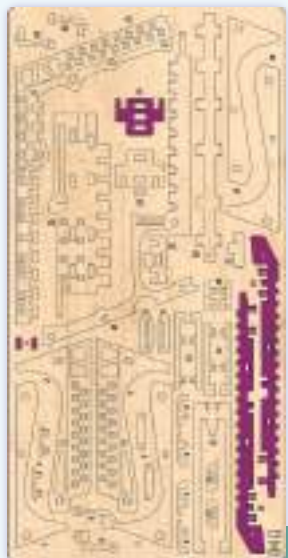
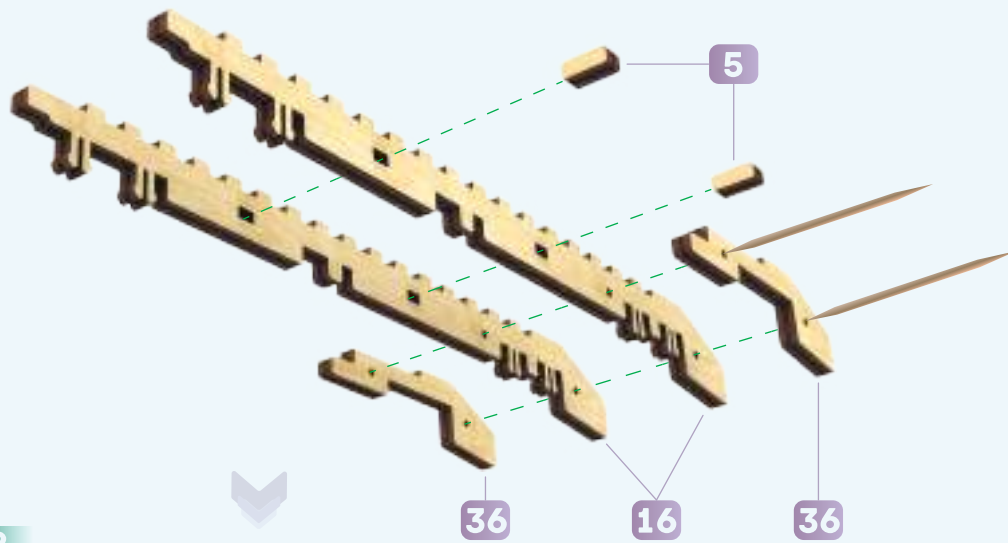

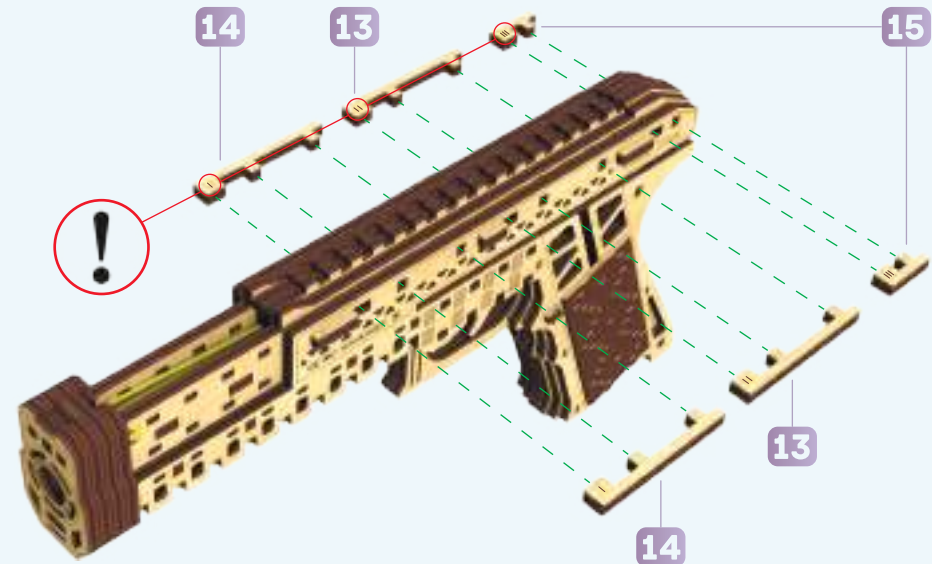
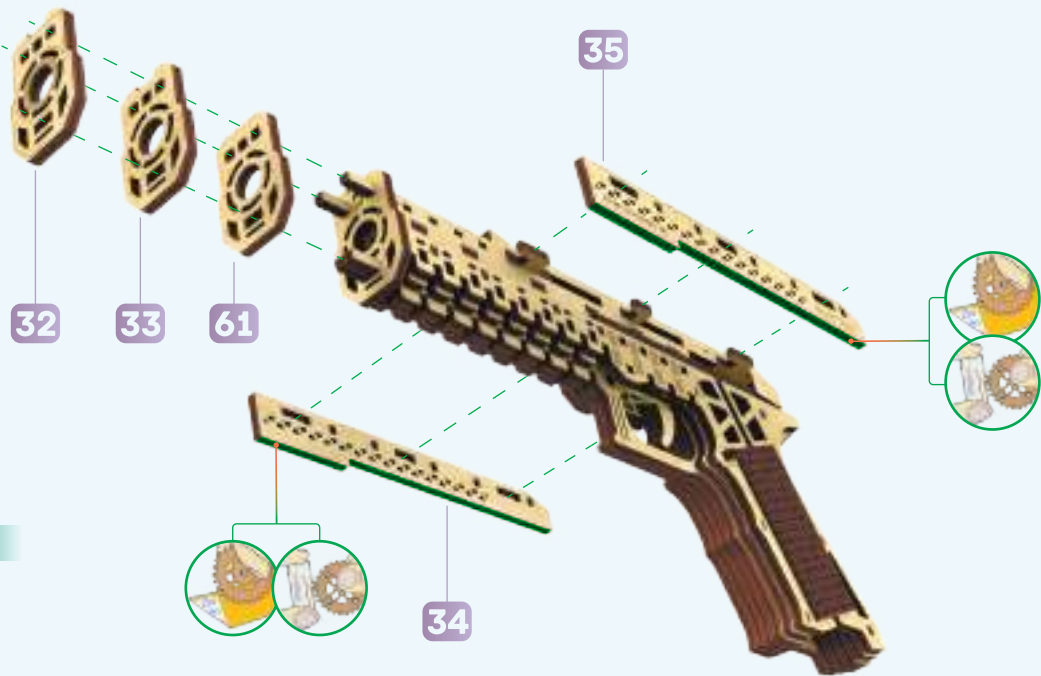
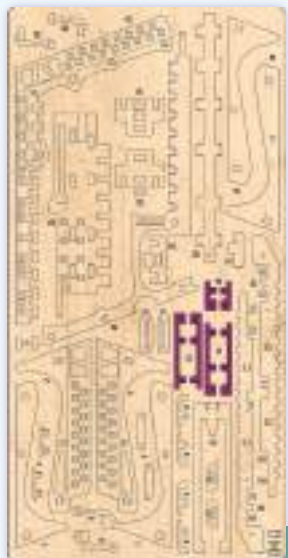
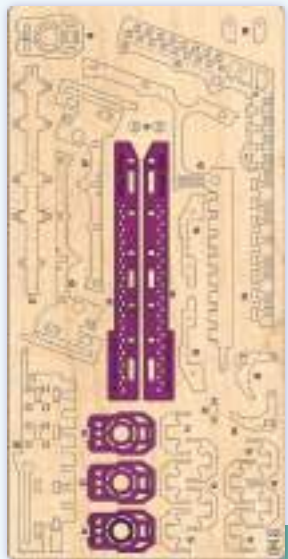



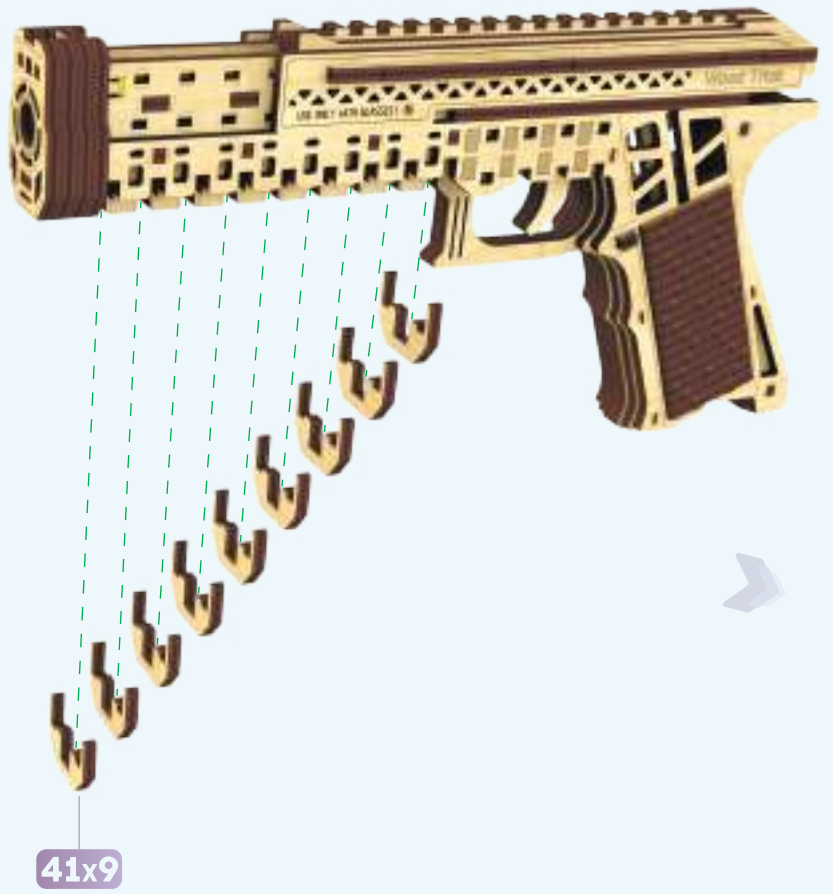



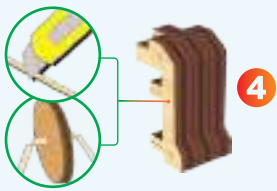
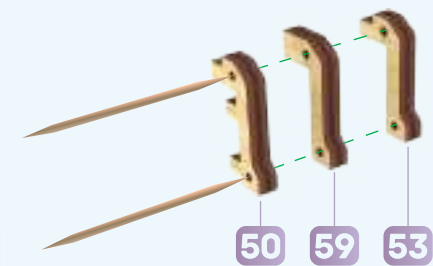
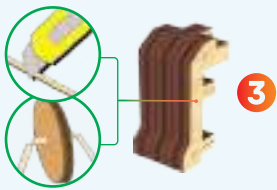
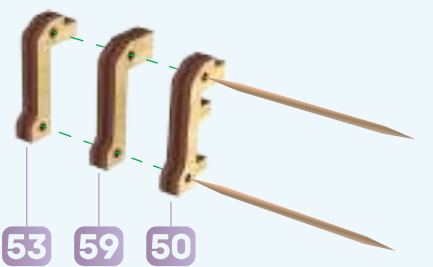
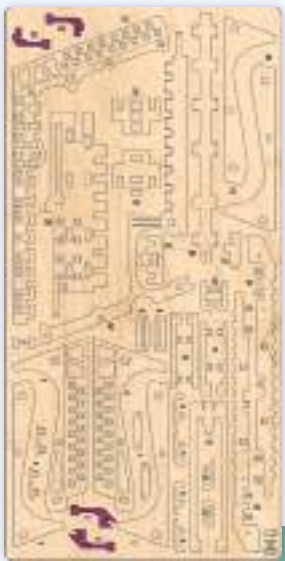
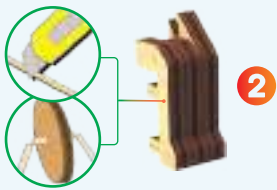
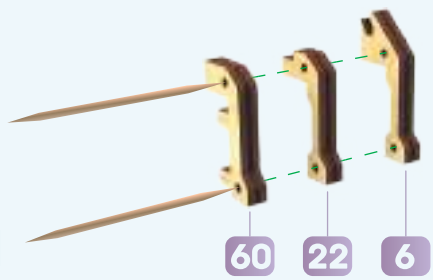
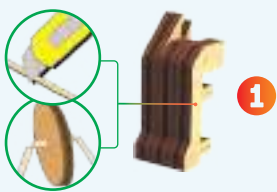
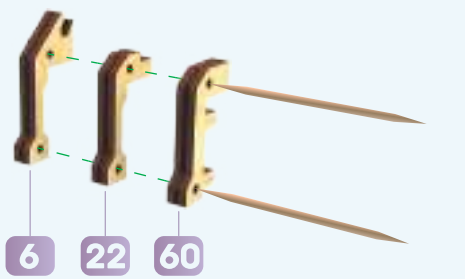

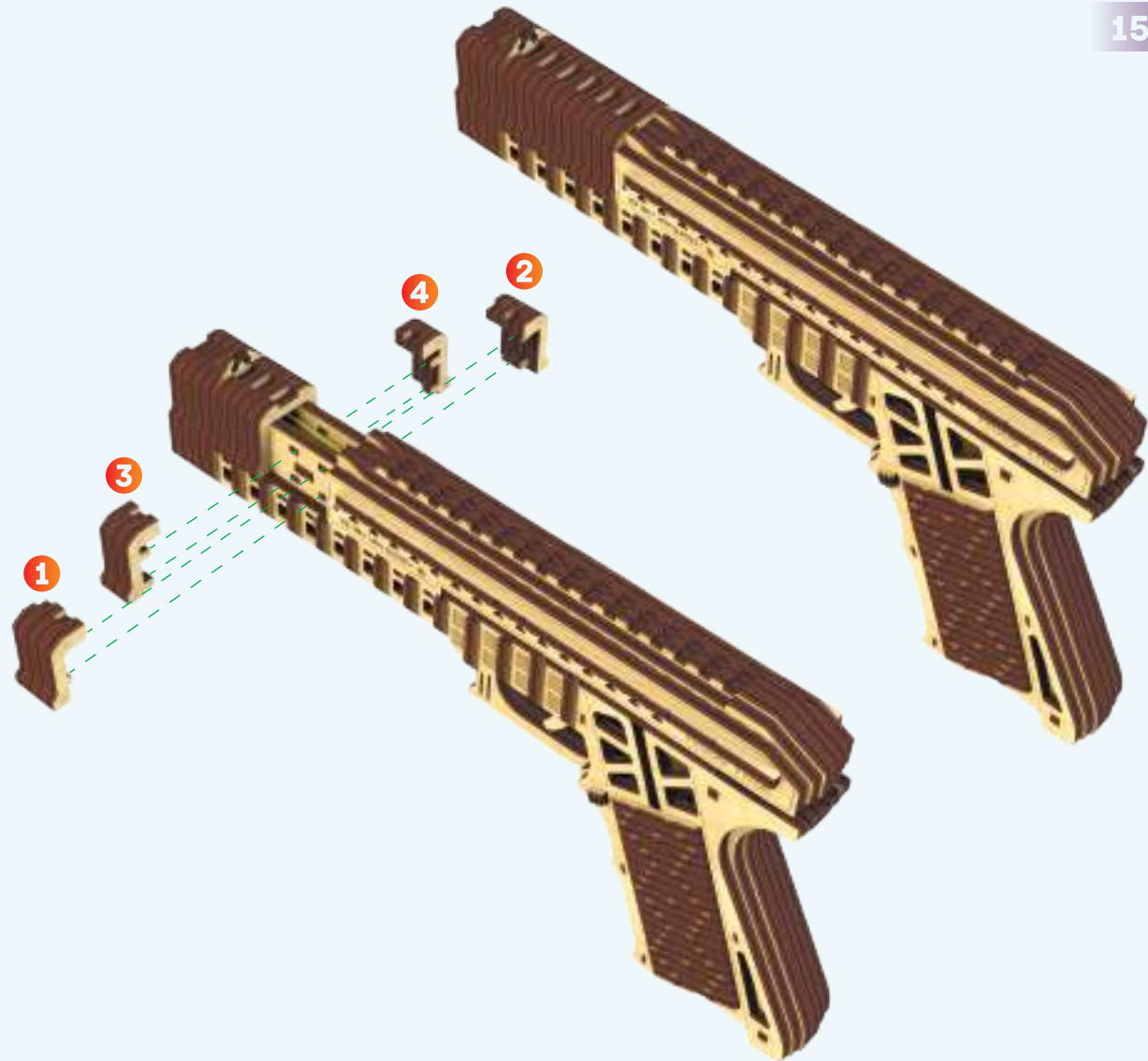
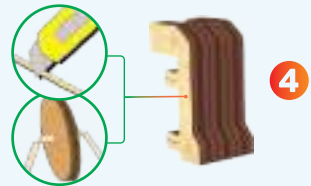
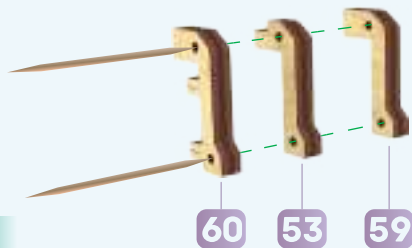
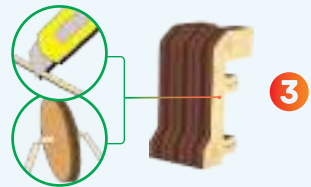
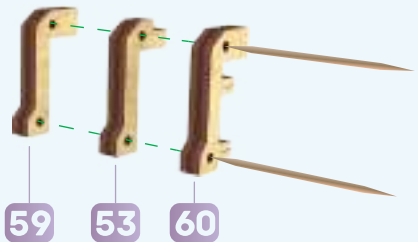
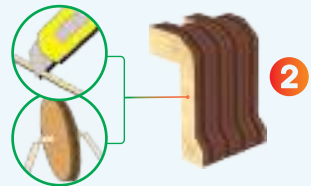
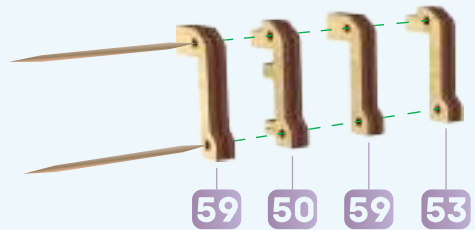
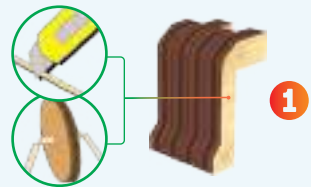
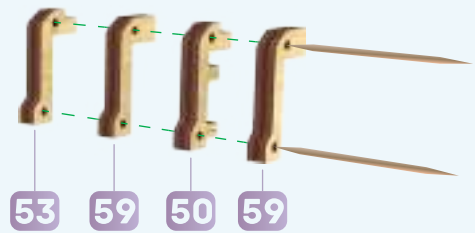



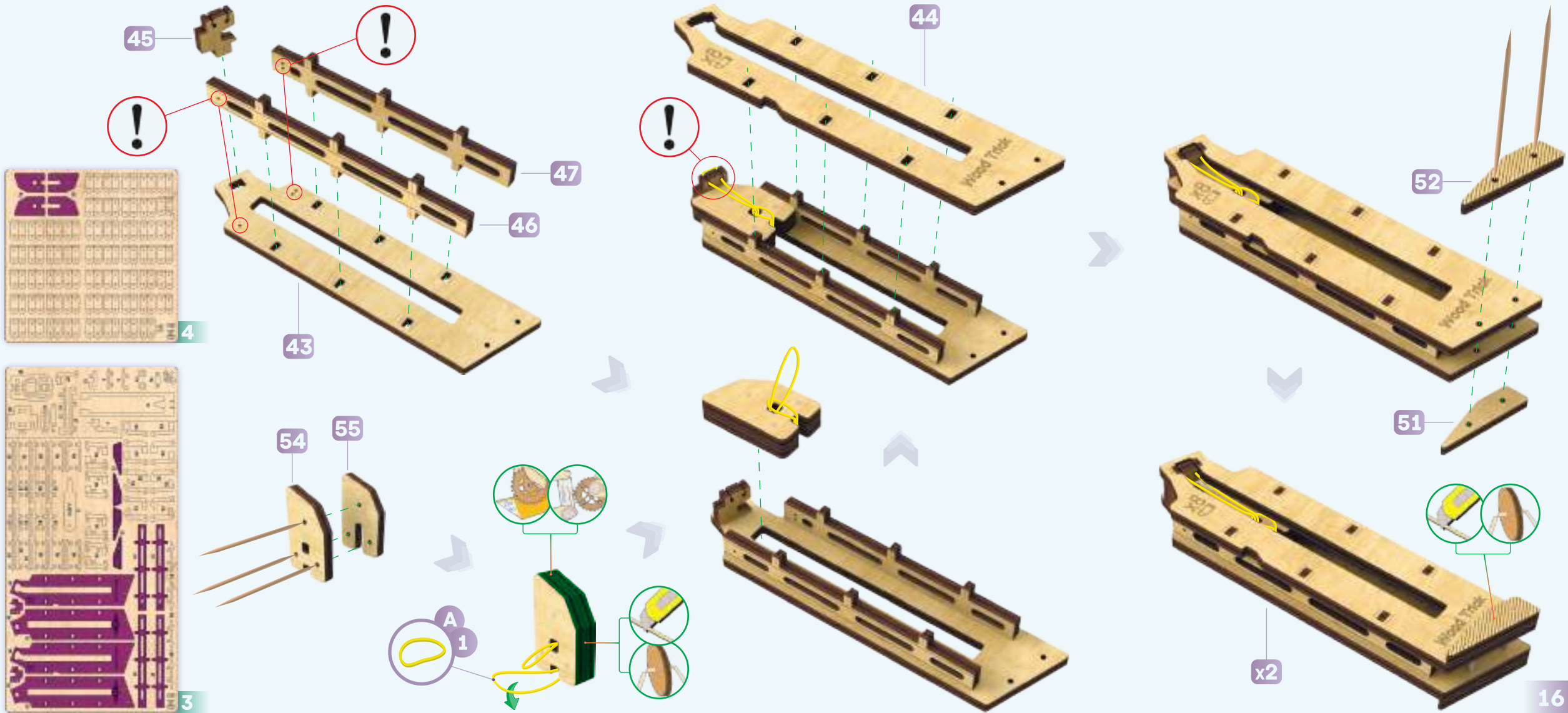











# HOW TO REPLACE A BROKEN PART

Sometimes it happens that a part of the WoodTrick model is lost or damaged.

But you have nothing to worry about because we have the replacement service. This option is free and quick, and you can easily use it for missed or damaged parts of your WoodTrick constructor.

## MAKE THE REPLACEMENT IN 5 SIMPLE STEPS

### STEP 1

Open the Replacement form on our website [woodtrick.com](http://woodtrick.com).

Or you can scan the QR code, which will redirect you to the replacement page.



### STEP 2

Indicate the reason for replacement.

There is no need to attach the photo or video of the broken part, it's enough to choose the reason in the list.

### STEP 3

Mention the name or the set number of the WoodTrick model with the missing part.

Name: DEFENDERS GUN  
Set number: WDTK063

### STEP 4

Choose the board\* which contains the part you need.

*\*All parts and all boards have the numbers. For the replacement you'll need to mention the № of the board. To find the correct board, use the assembly instruction.*

### STEP 5

Fill the delivery address and it's done!

### FREE REPLACEMENT

For each WoodTrick model we provide 2 (two) free replacements. We always send the full board to avoid the risks of damaging a small part during the delivery. For example, if you need part 14 which belongs to Board 1, we will send the whole Board 1.

### NEED SOME HELP?

In case you faced any difficulties with the replacement please contact us: [support@woodtrick.com](mailto:support@woodtrick.com). Our support team is available 24/7 and will assist with the issue. You can also get the consultation from support for any questions about assembly.