

EM8, EM20 and IM20 Meters

3A5588L

EN

**Use to dispense of petroleum based oils and anti-freeze. For professional use only.
Not approved for use in explosive atmospheres or hazardous locations.**

Maximum Working Pressure: 1500 psi (10.3 MPa, 103 bar)

Meter measures in gallons, quarts, pints and liters. The meter is factory set to quarts.

See page 2 for model information.



Important Safety Instructions

Read all warnings and instructions in this manual. Save these instructions.

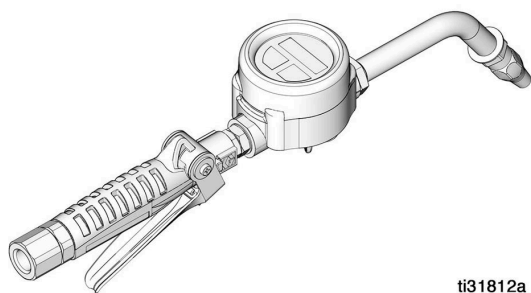

EM8

ti31812a

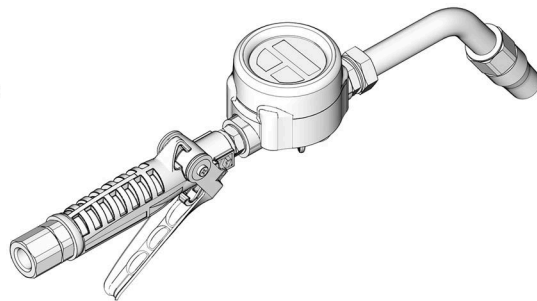

EM20



IM20

ti31814a



Models

In-Line Meter

Model No.	Inlet	Outlet	Thread
25C841	3/4	3/4	NPT
25U990	1/2	1/2	NPT

Metered Valves with Extension and Nozzle

EM8

Model No.	Swivel	Thread	Extension
25C903	1/2	NPT	Rigid
25C904	1/2	NPT	Flex
25C905	1/2	NPT	Gear Lube
25C907	1/2	BSPP	Rigid
25C908	1/2	BSPP	Flex
25C909	1/2	BSPP	Gear Lube
25C911	1/2	BSPT	Rigid

Model No.	Swivel	Thread	Extension
25C912	1/2	BSPT	Flex
25C913	1/2	BSPT	Gear Lube

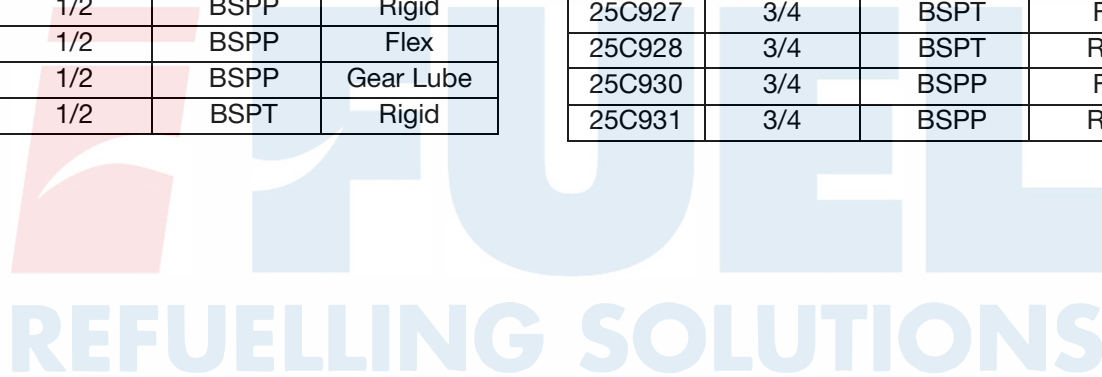

EM20

Model No.	Swivel	Thread	Extension
25C915	1/2	NPT	Flex
25C916	1/2	NPT	Rigid
25C918	3/4	NPT	Flex
25C919	3/4	NPT	Rigid
25C921	1/2	BSPT	Flex
25C922	1/2	BSPT	Rigid
25C924	1/2	BSPP	Flex
25C925	1/2	BSPP	Rigid
25C927	3/4	BSPT	Flex
25C928	3/4	BSPT	Rigid
25C930	3/4	BSPP	Flex
25C931	3/4	BSPP	Rigid





Warnings

The following warnings are for the setup, use, grounding, maintenance, and repair of this equipment. The exclamation point symbol alerts you to a general warning and the hazard symbols refer to procedure-specific risks. When these symbols appear in the body of this manual or on warning labels, refer back to these Warnings. Product-specific hazard symbols and warnings not covered in this section may appear throughout the body of this manual where applicable.

 <h1 style="margin: 0;">WARNING</h1>	
	<p>SKIN INJECTION HAZARD</p> <p>High-pressure fluid from dispensing device, hose leaks, or ruptured components will pierce skin. This may look like just a cut, but it is a serious injury that can result in amputation. Get immediate surgical treatment.</p> <ul style="list-style-type: none"> • Engage trigger lock when not dispensing. • Do not point dispensing device at anyone or at any part of the body. • Do not put your hand over the fluid outlet. • Do not stop or deflect leaks with your hand, body, glove, or rag. • Use only extensions that are designed for use with dispensing valve. • Do not use low-pressure flexible extension with this equipment. • Follow the Pressure Relief Procedure when you stop dispensing and before cleaning, checking, or servicing equipment. • Tighten all fluid connections before operating the equipment. • Check hoses and couplings daily. Replace worn or damaged parts immediately.
	<p>FIRE AND EXPLOSION HAZARD</p> <p>When flammable fluids are present in the work area, such as gasoline and windshield wiper fluid, be aware that flammable fumes can ignite or explode. To help prevent fire and explosion:</p> <ul style="list-style-type: none"> • Use equipment only in well-ventilated area. • Eliminate all ignition sources, such as cigarettes and portable electric lamps. • Ground all equipment in the work area. • Keep work area free of debris, including rags and spilled or open containers of solvent and gasoline. • Do not plug or unplug power cords or turn lights on or off when flammable fumes are present. • Use only grounded hoses. • Stop operation immediately if static sparking occurs or you feel a shock. Do not use equipment until you identify and correct the problem. • Keep a working fire extinguisher in the work area.

WARNING

 	<p>EQUIPMENT MISUSE HAZARD</p> <p>Misuse can cause death or serious injury.</p> <ul style="list-style-type: none"> • Do not operate the unit when fatigued or under the influence of drugs or alcohol. • Do not exceed the maximum working pressure or temperature rating of the lowest rated system component. See Technical Data in all equipment manuals. • Use fluids and solvents that are compatible with equipment wetted parts. See Technical Data in all equipment manuals. Read fluid and solvent manufacturer’s warnings. For complete information about your material, request Safety Data Sheet (SDS) from distributor or retailer. • Turn off all equipment and follow the Pressure Relief Procedure when equipment is not in use. • Check equipment daily. Repair or replace worn or damaged parts immediately with genuine manufacturer’s replacement parts only. • Do not alter or modify equipment. Alterations or modifications may void agency approvals and create safety hazards. • Make sure all equipment is rated and approved for the environment in which you are using it. • Use equipment only for its intended purpose. Call your distributor for information. • Route hoses and cables away from traffic areas, sharp edges, moving parts, and hot surfaces. • Do not kink or over bend hoses or use hoses to pull equipment. • Keep children and animals away from work area. • Comply with all applicable safety regulations.
	<p>PERSONAL PROTECTIVE EQUIPMENT</p> <p>Wear appropriate protective equipment when in the work area to help prevent serious injury, including eye injury, hearing loss, inhalation of toxic fumes, and burns. Protective equipment includes but is not limited to:</p> <ul style="list-style-type: none"> • Protective eyewear, and hearing protection. • Respirators, protective clothing, and gloves as recommended by the fluid and solvent manufacturer.
	<p>CALIFORNIA PROPOSITION 65</p> <p>This product contains a chemical known to the State of California to cause cancer, birth defects or other reproductive harm. Wash hands after handling.</p>

Typical Installation: IM20

The typical installation shown in FIG. 2 is only a guide. The components shown are typical; however it is not a complete system design. Contact your Graco distributor for assistance in designing a system to suit your needs. Additionally, these dispense valves can be installed on a console.

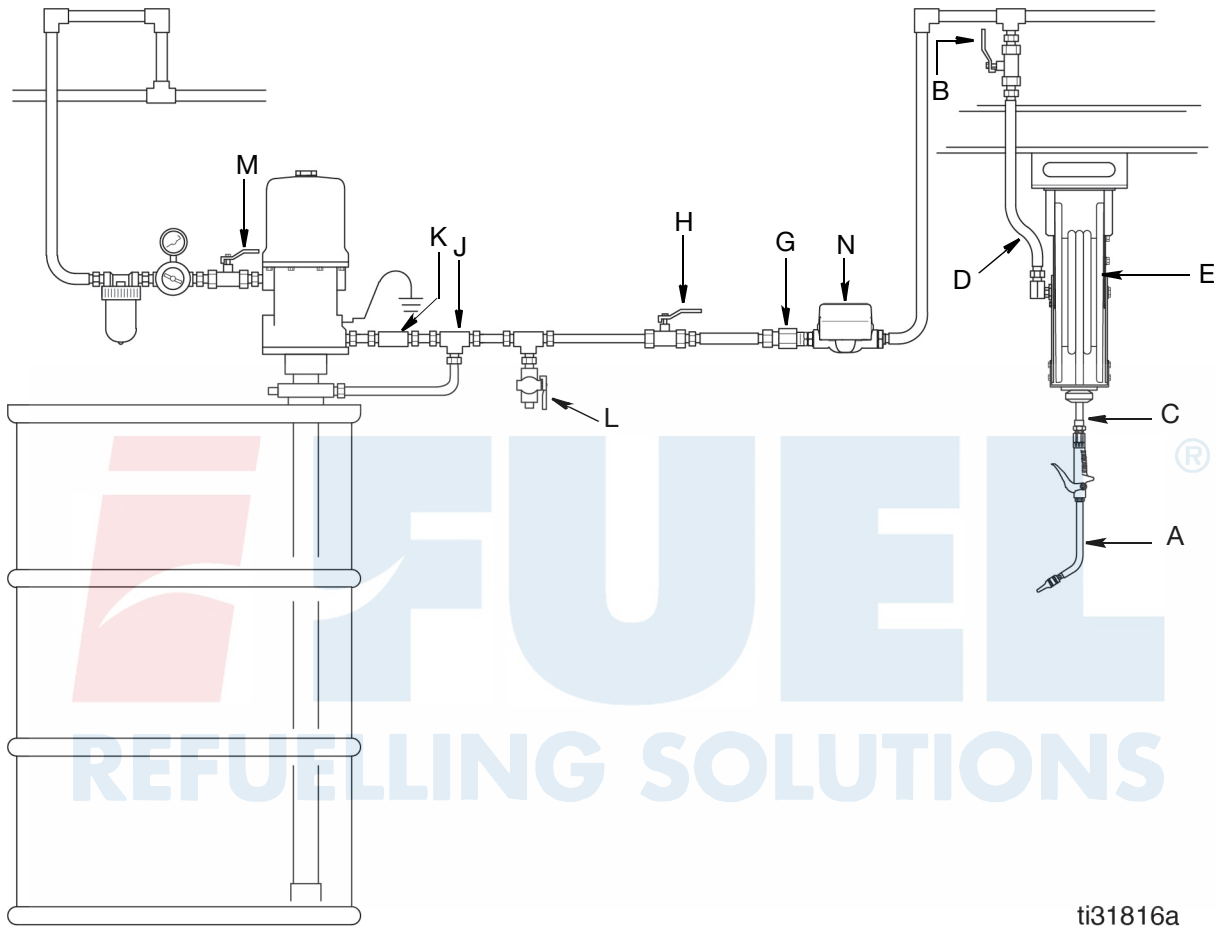

ti31816a

FIG. 2

Key:

- A Dispense Valve
- B Fluid Shutoff Valve - Hose Reel
- C Hose
- D Fluid Inlet Hose
- E Hose Reel
- G In-line strainer
- H Main Fluid Shutoff Valve
- J Pressure relief Valve
- K Check Valve
- L Bleed-off Valve (drain valve)
- M Bleed-type Master Air Valve
- N IM20 Inline Meter

NOTICE

- Do not over-tighten fittings. Excessive torque will crack the casting. Only tighten fittings 2.5 ± 0.5 turns past finger tight. Do not exceed 80 ft.-lbs (9.04 N•m).
- Flush lines before installing equipment in the system to prevent contamination which can cause equipment damage or malfunction. See Flushing Procedure, page 8.

Grounding



The equipment must be grounded to reduce the risk of static sparking. Static sparking can cause fumes to ignite or explode. Grounding provides an escape wire for the electric current.

Pump: follow manufacturer's recommendations.

Air and fluid hoses: use only grounded hoses.

Air compressor: follow manufacturer's recommendations.

Fluid supply container: follow local code.

To maintain grounding continuity when flushing or relieving pressure: hold metal part of the dispense valve firmly to the side of a grounded metal pail, then trigger the valve.

Pressure Relief Procedure



Follow the Pressure Relief Procedure whenever you see this symbol.



This equipment stays pressurized until pressure is manually relieved. To help prevent serious injury from pressurized fluid, such as skin injection, splashing fluid and moving parts, follow the Pressure Relief Procedure when you stop dispensing and before cleaning, checking, or servicing the equipment.

1. Turn off power supply to the pump.
2. Trigger the dispense valve into a grounded waste container to relieve pressure.
3. Open any bleed-type master air valves and fluid drain valves in the system.
4. Leave the drain valve open until you are ready to pressurize the system.
5. If you suspect the valve, extension or nozzle is clogged or that pressure has not been fully relieved:
 - a. VERY SLOWLY loosen the fitting nut on the fluid line to relieve pressure gradually.
 - b. Then loosen it completely.
 - c. Clear the obstruction in the hose or tip.

The reference letters used in the instructions on this page refer to Typical Installation, FIG. 1, page 5 and FIG. 2, page 6.

Pre-Installation Procedure



1. **Relieve pressure**, page 7.
2. Close the hose reel fluid shut-off valve (B).
3. Ground the hose and reel or console. See Grounding, page 7. Do not use PTFE tape on the pipe joints; it may cause a loss of ground across the pipe joint.

Flushing

If this is a new installation or if the fluid in the lines is contaminated, flush the lines before installing the dispense valve. To avoid contaminating your fluid with oil, flush the equipment with a compatible solvent before using the equipment.

NOTE: The dispense valve should not be installed on the hose when flushing the equipment.

1. **Relieve pressure**, page 7.
2. Close the hose reel fluid shut-off valve (B) at each dispense position.
3. If an existing installation, remove dispense valve from hose.
4. Place the hose end into a container for waste fluid. Secure the hose in the container so it will not come out during flushing.

NOTE: If you have multiple dispense positions, first flush the dispense position farthest from the pump, and work your way toward the pump.

5. Slowly open the hose reel fluid shut-off valve (B) at the dispense position. Flush out a sufficient amount of fluid to ensure that the entire system is clean, then close the valve.
6. Repeat step 5 at all dispense positions.

Installing Meter

To install a new meter in an EXISTING installation, begin instructions with Step 1 and 2.

To install a new meter in a NEW installation, begin instructions with Step 3.



1. **Relieve pressure**, page 7.
2. Loosen and disconnect the hose from the dispense valve you are replacing.

For Steps 3 - 8, refer to FIG. 3.

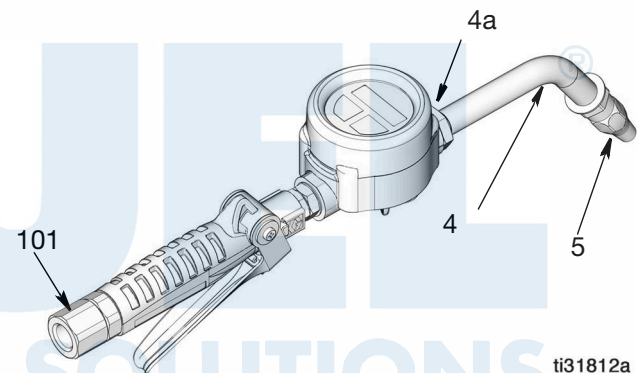

FIG. 3

ti31812a

3. Thread the extension, (4) into the dispense valve outlet until o-ring makes contact with the meter.
4. Position the extension for proper alignment.
5. Wrench tighten the jam nut (4a).
6. Thread the new nozzle (5) onto the extension (4), and tighten firmly.
7. Apply thread sealant to the male threads of the hose fitting. Thread the hose fitting into the swivel (101). Tighten firmly.
8. Open all dispense position shut-off valves (B). Start the pump to pressurize the system. See the Operation section, page 9 for operation instructions.
9. To ensure dispensing accuracy, purge all air from the fluid lines and dispense valves before you use them.

Operation

To Activate the Digital Display

Press the **RESET** key to clear the meter before starting a new dispense cycle. This is the best way to activate the meter, because it also clears the quantity of the last dispense cycle.

The digital display can also be activated by pressing the **TOTAL** key or by running fluid through the meter. (FIG. 4)



FIG. 4

NOTE: The digital display on the meter goes blank after approximately one minute of non-use.

Function of TOTAL

To see the accumulated total of fluid dispensed through the meter, press the **TOTAL** key. The meter can accumulate a running total of up to 19,999 units dispensed before returning to zero. (FIG. 5)



FIG. 5: Example of accumulated total

Function of RESET

Press the **RESET** key to clear the quantity of the last dispense cycle and return the digital display to all zeros. (FIG. 4).

Setup Mode

1. Press the **TOTAL** and **RESET** buttons (FIG. 7) together.
 - All segments of the digital display illuminate for approximately 6 seconds.
 - The software revision displays for approximately 2 seconds.
 - The meter goes blank and the volume unit blinks.

The meter is now in Setup Mode.

2. Release the **TOTAL** and **RESET** buttons.

Volume Unit

1. The factory default unit of measure is Quarts (QTS).

Repeatedly press the **TOTAL** button (FIG. 4) to change the displayed unit of measure. FIG. 6 shows examples of each UOM screen.

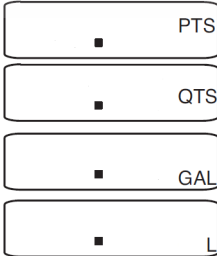

FIG. 6: Example of Units of Measure (UOM)

2. When the desired UOM is displayed, press the **RESET** button (FIG. 4) to save the selection.

3. CAL appears on the display as shown in FIG. 7. CAL indicates the meter is ready for Calibration Mode.

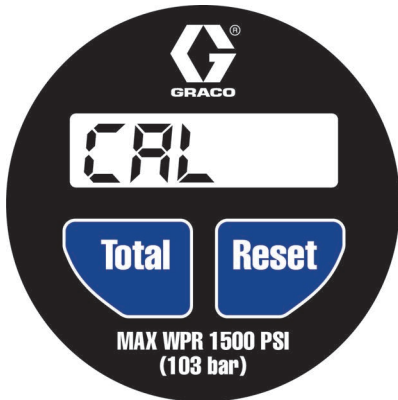

FIG. 7

4. To save the current Calibration factor, press **RESET** and the unit will save and exit setup.

Meter Recalibration

To recalibrate the meter:

1. Dispense 1 Quart (or 1 Liter) of fluid into a clean, calibrated container.
2. When the volume of fluid in the calibrated container reaches 1 Quart (or 1 Liter), stop the dispense.

NOTE: During the dispense the numbers on the display and the UOM flash on the screen.

3. Press and hold the **TOTAL** button until 1.00 QTS (or 1.00 L) displays steady on the screen. FIG. 8 shows the meter displaying 1.00 QTS has been dispensed.

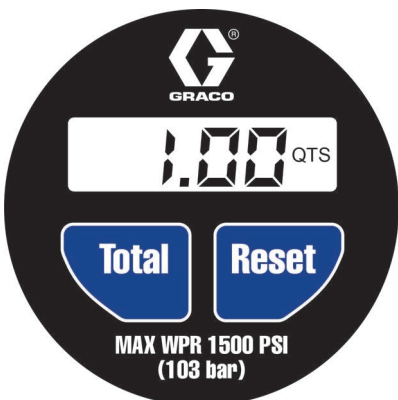

FIG. 8

4. If you are satisfied with the dispense, press the **RESET** button to save the new calibration factor and exit the Setup Mode.
5. If the dispense was not accurate and needs to be performed again, repeat Step 1 - Step 4.

NOTE:

- To interrupt or restart the calibration dispense at any time during the dispense, push the **TOTAL** button. This will reset the display back to 00.00 to start over.
- If **RESET** is pressed before the calibration factor is calculated, the meter will disregard the new calibration information and exit the Setup Mode.

Restoring the Default Calibration Factor

From the CAL screen:

1. Start a dispense to register a count.
2. Quickly press and release the **TOTAL** button to reset the calibration dispense to 00.00.

NOTE: The UOM; either QTS or L, will flash on the display.

3. Press and hold **TOTAL** until 1.00 displays on the screen and the UOM stops flashing.
4. Press the **RESET** button to save the default calibration factor and exit the Setup Mode.

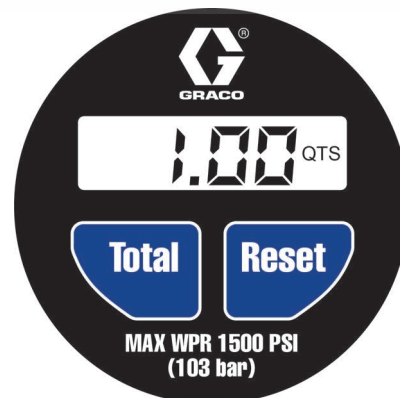

FIG. 9

To Verify the Accuracy

1. Use a clean, calibrated container.

NOTE: If using a single container, be sure to clean it after each dispense.

2. Set pump air pressure at the lowest possible setting for dispensing fluid.
3. Place the tip of the nozzle at the bottom of the calibrated container.

NOTE: If the tip of the dispense valve does not reach the bottom of the calibrated container, use a length of plastic tubing over the tip of the nozzle to ensure liquid enters the container from the bottom.

4. Trigger the dispense valve slowly. Dispense fluid until the calibrated container is full.
5. Allow product to sit for 20 minutes, then compare the actual, physical measurement in the calibrated container to the measurement displayed on the meter.

NOTE: The procedure above will determine if the meter is accurately dispensing the product and minimize testing errors. Some variance may occur depending on the viscosity of the fluid. If this procedure determines that the meter is not accurate recalibrate the meter using the procedure outlined in the Meter Recalibration instructions, page 10.

For Maximum Dispensing Accuracy

(gallon/quart/pint dispenses only)

Set the meter to dispense in pints or quarts when dispensing 1 gallon or less.

Always press the **RESET** on the key pad to clear the meter before a new dispense cycle.

Dispensing Instructions

				
To reduce the risk of serious bodily injury, including fluid injection, never exceed the maximum working pressure of the valve you are using or the lowest rated component in your system.				

1. Open dispense nozzle and point it into the fill port or a container.
2. Fully depress the trigger lock button and squeeze the trigger toward the valve body (FIG. 10).

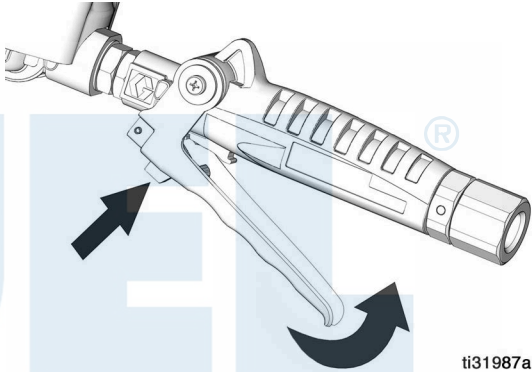

FIG. 10

3. To lock the valve open, depress the trigger lock button while continuing to squeeze the trigger to the valve body.

Slowly release trigger while, at the same time, depressing the trigger lock button.

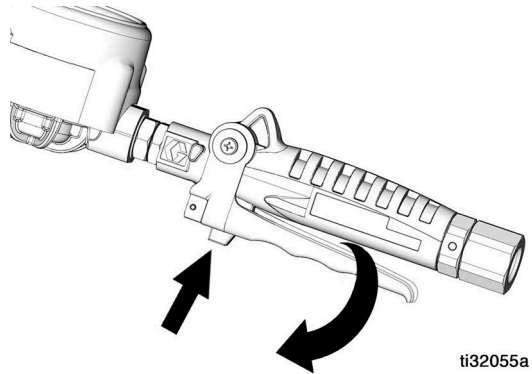

FIG. 11

4. To release the trigger lock, pull the trigger toward the valve body to release the trigger lock.

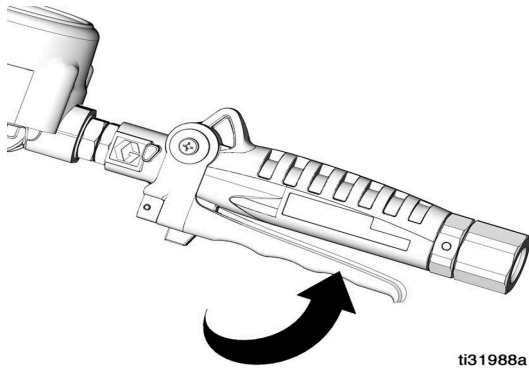

FIG. 12

5. Release the trigger to stop dispensing.

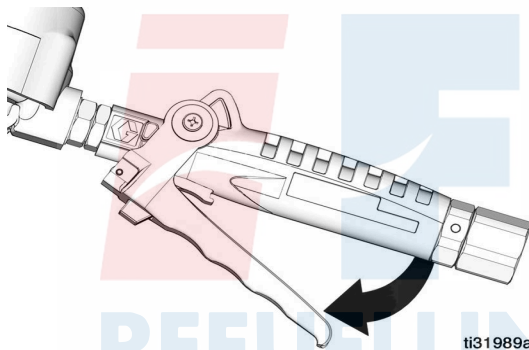

FIG. 13

Battery Installation



1. Relieve pressure, page 7.
2. Remove impact guard (14) (FIG. 14).
3. Remove the 4 screws (13) from the meter (3) housing, and remove the electronics bezel (3a) (FIG. 14).
4. Remove battery retainer (3b) (FIG. 14).

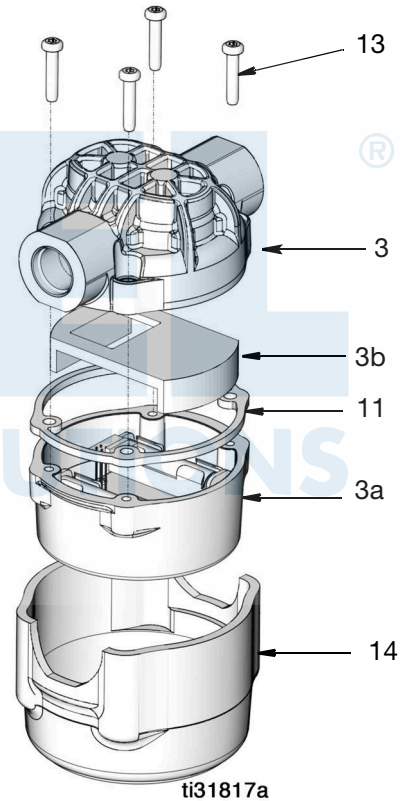

FIG. 14

5. Pull up battery retention ribbon located under batteries to unseat batteries as shown in FIG. 15. Dis-

pose of the batteries according to local regulations for battery disposal.

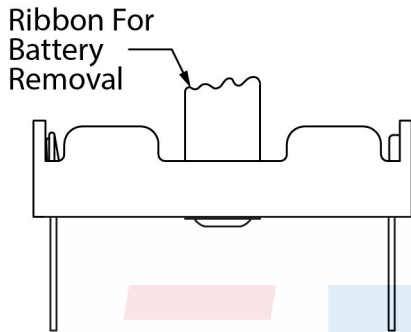
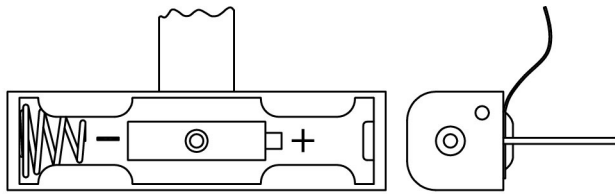

FIG. 15

6. Insert the new battery as noted on the battery holder. Press down firmly on the battery. See FIG. 15 to identify the negative and positive sides of the battery.

NOTE: Be sure battery retention ribbon is in place beneath battery to assist with future battery removal.

7. Reinstall battery retainer (3b) (FIG. 14).
8. (Reinstall the bezel seal (11) over the lip on the top of the metering unit (3). Place electronics bezel (3a) onto bezel seal (11) (FIG. 14).
9. Reinstall screws (13) (FIG. 14). Tighten the screws in a diagonal pattern to 15-25 in-lbs (1.7-2.8 N-m).
10. Reinstall the impact guard (14) (FIG. 14).

Parts

Valve (Ref 1, page 16)

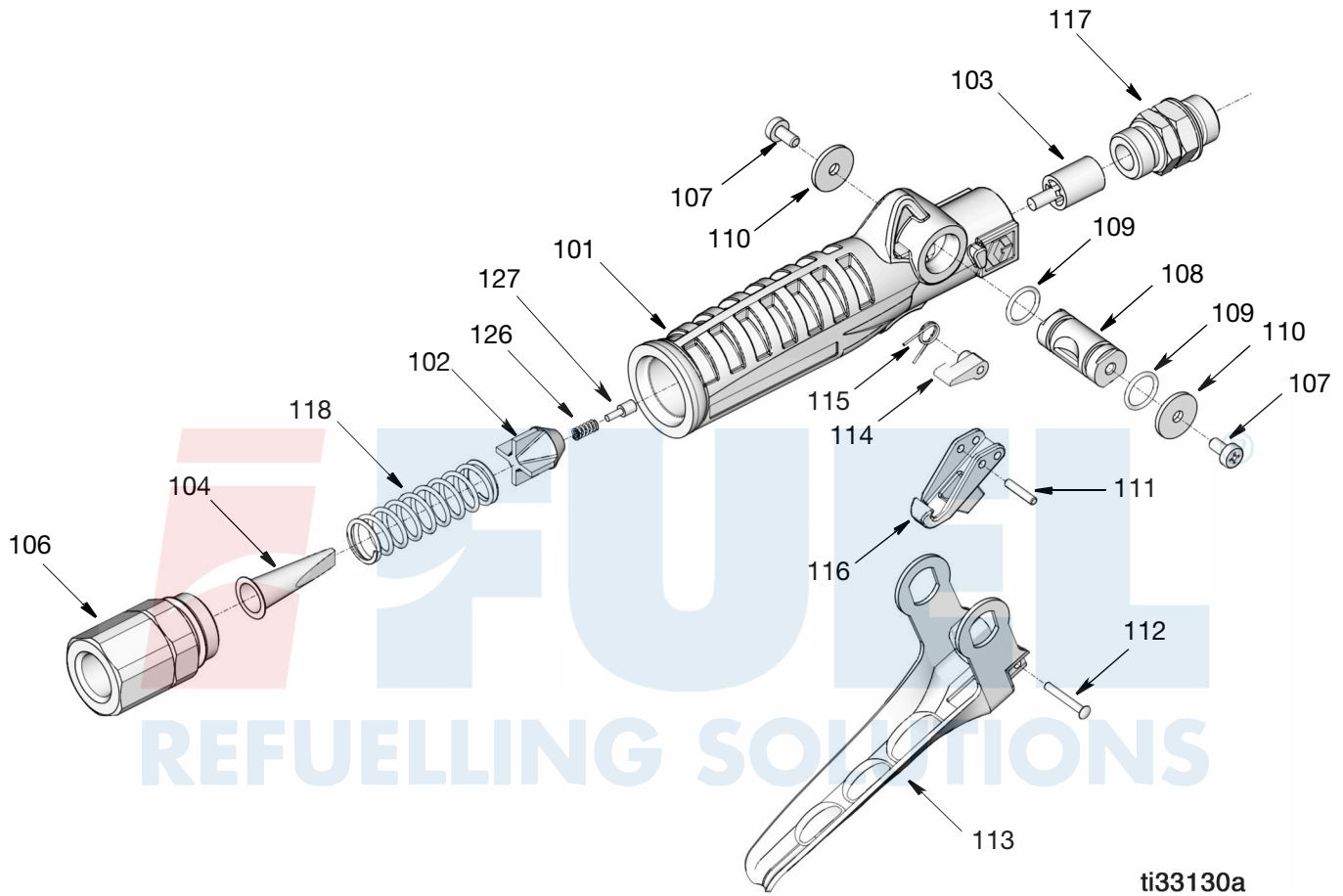

ti33130a

Valve (Ref 1, page 16)

Ref	Part No.	Description	Qty	Ref	Part No.	Description	Qty
101		HANDLE, valve, standard duty, models 25D433-25D435	1	117	130168	FITTING, 3/4" ORB x 3/4" ORB, models 25D433-24D435	1
		HANDLE, valve, medium flow, models 25D436 to 25D441	1		130169	FITTING, 7/8" ORB x 7/8" ORB, models 25D436-24D441	1
102★	15U704	SEAT, valve	1	118	113493	SPRING, compression	1
103‡	277673	ROD, push, valve	1	126★	15U701	SPRING, secondary	1
104◆★		STRAINER, wire mesh	1	127★	15U700	PLUNGER, trigger lift	1
106	238399	SWIVEL, straight, NPT, model 25D433	1	* Parts included in Trigger Kit 25D937. Parts come pre-assembled. ★ Parts included in Valve Kit 25D935. ‡ Parts included in Cam Repair Kit 25E145. ◆ Standard 80 mesh strainer and swivel o-ring included in 25D906. For increased filtration in anti-freeze applications, order Kit 25U000. Includes 200 mesh strainer and swivel o-ring.			
	24H382	SWIVEL, straight, BSPP, model 25D434	1				
	24H383	SWIVEL, straight, BSPT, model 25D435	1				
	247344	SWIVEL, straight, 1/2" NPT, model 25D436					
	247345	SWIVEL, straight, 3/4 in, NPT, model 25D437	1				
	24H097	SWIVEL, straight, 1/2-14 BSPT, model 25D438	1				
	24H098	SWIVEL, straight, 1/2-14 BSPP, model 24D439	1				
	24H099	SWIVEL, straight, 3/4-14 BSPT, model 24D440	1				
	24H100	SWIVEL, straight, 3/4-14, BSPP, model 24D441	1				
107‡	110637	SCREW, mach, panhead	2				
108‡	191315	CAM	1				
109‡	113574	SEAL, o-ring	2				
110‡	191552	WASHER, flat	2				
111*		PIN, dowel	1				
112*		LATCH, pin	1				
113*		TRIGGER	1				
114*		LATCH, arm	1				
115*		SPRING, latch	1				
116*		LATCH, lever	1				

Parts

EM8, EM20 and IM20 Meters

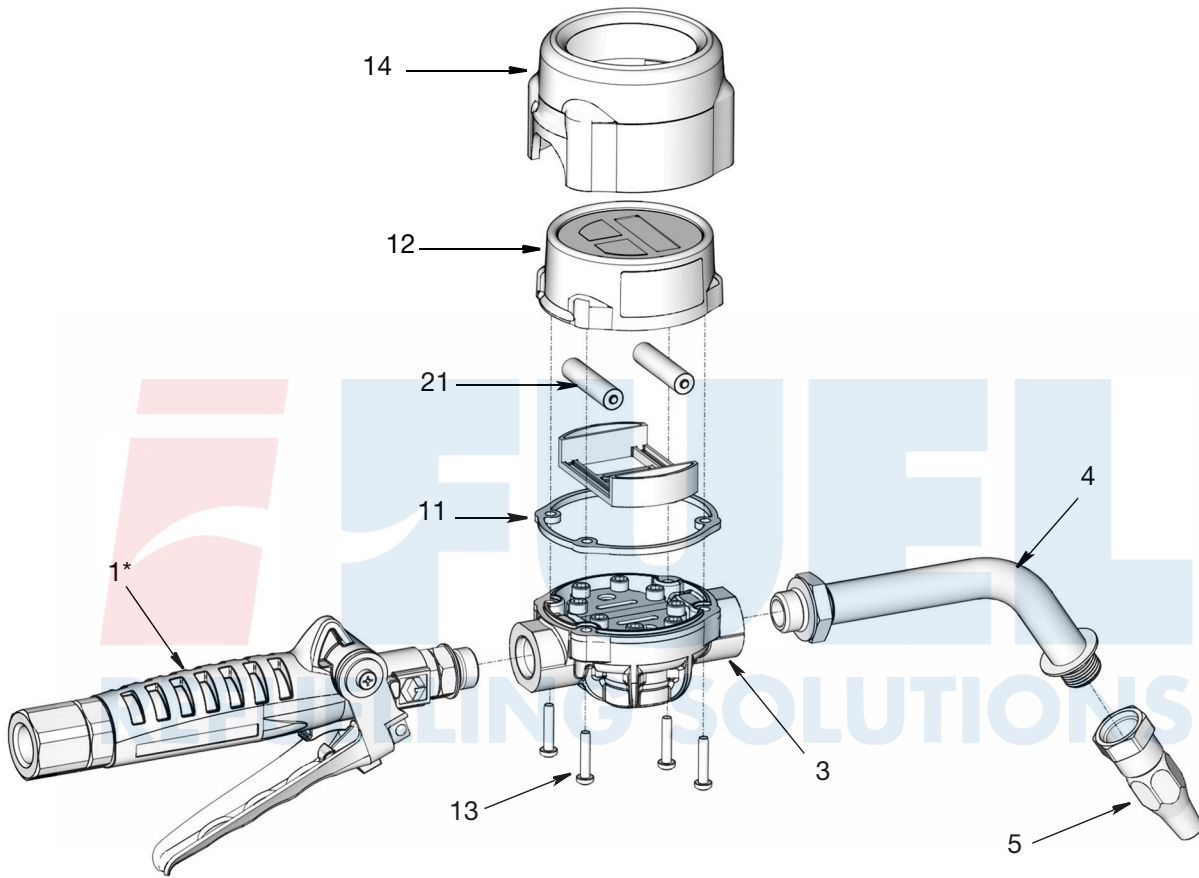

* See Valve Parts, page 14

Parts

In-Line Meter, IM20

Ref	Part No.	Description	Qty
3		HOUSING, meter	1
11◆★	129949	SEAL, bezel	1
12★		CONTROL, electronic, English	1
13◆★	131172	SCREW, torx pan hd	4
14	133115	GUARD, impact	1
21◆★		BATTERIES, AAA	2

EM8 Meter

Ref	Part No.	Description	Qty
1*	25D433	VALVE, EM8, 1/2 NPT x 3/4 ORB, models 25C903, 25C904, 25C905	1
	25D434	VALVE, EM8, 1/2 BSPP x 3/4 ORB, models 25C907, 25C908, 25C909	1
	25D435	VALVE, EM8, 1/2 BSPT x 3/4 ORB, models 25C911, 25C912, 25C913	1
3		HOUSING, meter	1
4	255194	EXTENSION, nozzle, models 25C903, 25C907, 25C911	1
	16Y863	HOSE, coupled, 3/8 inch ID, 2000 psi (137.9 bar, 13.79 MPa) models 25C904, 25C908, 25C912	1
	255854 †	KIT, nozzle, rigid, models 25C905, 25C909, 25C913	1
5	17T207	NOZZLE, manual, models 25C903, 25C904, 25C907, 25C908, 25C911, 25C912	1
11◆★	129949	SEAL, bezel	1
12★		CONTROL, electronic, English	1
13◆★	131172	SCREW, torx pan hd	4
14★	133115	GUARD, impact	1
21◆		BATTERIES, AAA	2

EM20 Meter

Ref	Part No.	Description	Qty
1*	25D436	VALVE, EM20, 1/2 NPT x 7/8 ORB, models 25C915, 25C916	1
	25D437	VALVE, EM20, 3/4 NPT x 7/8 ORB, models 25C918, 25C919	1
	25D438	VALVE, EM20, 1/2 BSPT x 7/8 ORB, models 25C921, 25C922	1
	25D939	VALVE, EM20, 1/2 BSPP x 7/8 ORB, models 25C924, 25C925	1
	25D440	VALVE, EM20, 3/4 BSPT x 7/8 ORB, models 25C927, 25C928	1
	25D441	VALVE, EM20, 3/4 BSPP x 7/8 ORB, models 25C930, 25C931	
3		HOUSING, meter	1
4	255859 ◆	KIT, nozzle, flex, models 25C915, 25C918, 25C921, 25C924, 25C927, 25C930	1
	255921 ‡	KIT, nozzle, rigid, models 25C916, 25C919, 25C922, 25C925, 25C928, 25C931	1
11◆★	129949	SEAL, bezel	1
12★		CONTROL, electronic, English	1
13◆★	131172	SCREW, torx pan hd	4
14	133115	GUARD, impact	1
21◆★		BATTERIES, AAA	2

* See Valve Parts, page 14

◆ Kit includes Coupled 1 Foot Hose and Heavy Duty Nozzle

† Kit includes: Gear Lube Extension, Nozzle and 3/4 x 1/2 Adapter O-Ring

‡ Kit includes Rigid Nozzle Extension and a Heavy Duty Nozzle

◆ Parts included in Battery Kit 25D936.

★ Parts included in Electronic Kit 25D934.

Troubleshooting



Relieve pressure before you check or repair the dispensing valve. Be sure all other valves, controls and the pump are operating properly.

Problem	Cause	Solution
Display does not activate or is showing unintelligent characters	Electronic control is malfunctioning	Replace electronic control. Order EM8/20 Electronics Kit 25D934. Kit includes electronic control, seal and mounting screws.
	Batteries in electronic control are depleted	Replace battery. Order EM8/20 Battery Repair Kit 25D936. Kit includes seal, batteries and retainer.
Display segments do not illuminate	Loose board mounting screws cause electronic control to malfunction	Tighten the three board mounting screws on the inside of the electronic control. If this does not correct the problem, replace the electronic control. Order Electronics Kit 25D934.
Slow or no fluid flow	Strainer (4) is clogged.	Clean or replace strainer (4).
	Pump pressure is low.	Increase pump pressure.
	Shut off valve is not fully open.	Fully open shut off valve.
	Foreign material is jammed in the meter element.	Contact your local Graco distributor for repair or replacement.
Fluid leaks from swivel (101)	Swivel (101) is loose.	Torque the swivel (101) to 15 to 20 ft-lbs (20 to 27 N•m). If the problem remains, contact your Graco distributor for repair or replacement.
	Damaged or worn o-ring(s) (109)	Replace the o-rings (109) and torque the swivel (101) to 15-20 ft-lbs (20 to 27 N•m). If the problem remains, contact your Graco distributor for repair or replacement.
Fluid flow does not stop when valve is closed	Worn valve seat (102)	Replace valve seat (102). Order EM8/20 Valve Kit 25D935.
Fluid leaks from trigger barrel seals -	Damaged or worn o-ring(s) (109)	Replace cam assembly. Order Em8/20 Cam Repair Kit 25E145.
Trigger lock on/off feature does not work	Damaged trigger components	Replace trigger assembly. Order EM8/20 Trigger Kit 25D937.

Technical Specifications

EM8, EM20, IM20 Meters		
	US	Metric
Recommended maximum flow rate (under normal operating conditions)		
EM8 Metered Dispense Valve	8 gpm	30.3 lpm
EM20 Metered Dispense Valves	20 gpm	75.7 lpm
IM20 Inline Meter	20 gpm	75.7 lpm
Minimum flow rate (under normal operating conditions)		
EM8 Metered Dispense Valve	0.25 gpm	0.95 lpm
EM20 Metered Dispense Valves	0.25 gpm	0.95 lpm
IM20 Inline Meter	0.25 gpm	0.95 lpm
Meter Pressure Loss: Tested in 10W oil at 70°F (21°C). Flow rate varies with fluid pressure, temperature, viscosity, inlet fitting size and nozzle type.		
EM8 Metered Dispense Valve	30 psi at 6 gpm	2.07 bar at 22.7 lpm
EM20 Metered Dispense Valve	85 psi at 12 gpm	5.86 bar at 45.4 lpm
IM20 Inline Meter	35 psi at 12 gpm	2.41 bar at 45.4 lpm
Maximum operating pressure		
All models	1500 psi	10 MPa, 102 bar
Weight		
EM8 Dispense Valve	3 lb.	1.36 kg
EM20 Dispense Valves	3 lb. 1 oz.	1.39 kg
IM20 Inline Meter	1 lb. 4 oz.	0.57 kg
Temperature		
Operating Temperature Range	- 22°F to 180°F	-30°C to 82°C
Storage Temperature Range	- 40°F to 185°F	-40°C to 85°C
Ingress Protection		
All Models	IP69K as per DIN 40050-9	
Inlet Sizes		
EM8 Metered Dispense Valve	1/2 in. NPT	1/2 in. BSPP 1/2 in. BSPT
EM20 Metered Dispense Valves	1/2 in. NPT 3/4 in. NPT	1/2 in. BSPP 3/4 in. BSPP 1/2 in. BSPT 3/4 in. BSPT
IM20 Inline Valves	3/4 in. NPT	
Outlet Sizes		
EM8 Metered Dispense Valve	3/4 in. ORB	
EM20 Metered Dispense Valves	7/8 in. ORB	
IM20 Inline Meter	3/4 in. NPT	
Battery		
All models	2 AAA	
Materials of Construction		
Wetted materials	aluminum, stainless steel, carbon steel, acetal, nitrile rubber, Geolast™	

Graco 5-Year Meter and Valve Warranty

Graco warrants all equipment referenced in this document which is manufactured by Graco and bearing its name to be free from defects in material and workmanship on the date of sale to the original purchaser for use. With the exception of any special, extended or limited warranty published by Graco, Graco will, for a period from the date of sale as defined in the table shown below, repair or replace equipment covered by this warranty and determined by Graco to be defective. This warranty applies only when the equipment is installed, operated and maintained in accordance with Graco's written recommendations.

Component	Warranty Period
Structural Components	5 years
Electronics (where applicable)	3 years
Wear Parts - including, but not limited to, o-rings, seals, valves, and trigger lock	1 year

This warranty does not cover, and Graco shall not be liable for general wear and tear, or any malfunction, damage or wear caused by faulty installation, misapplication, abrasion, corrosion, inadequate or improper maintenance, negligence, accident, tampering, or substitution of non-Graco component parts. Nor shall Graco be liable for malfunction, damage or wear caused by the incompatibility of Graco equipment with structures, accessories, equipment or materials not supplied by Graco, or the improper design, manufacture, installation, operation or maintenance of structures, accessories, equipment or materials not supplied by Graco.

This warranty is conditioned upon the prepaid return of the equipment claimed to be defective to an authorized Graco distributor for verification of the claimed defect. If the claimed defect is verified, Graco will repair or replace free of charge any defective parts. The equipment will be returned to the original purchaser transportation prepaid. If inspection of the equipment does not disclose any defect in material or workmanship, repairs will be made at a reasonable charge, which charges may include the costs of parts, labor, and transportation.

THIS WARRANTY IS EXCLUSIVE, AND IS IN LIEU OF ANY OTHER WARRANTIES, EXPRESS OR IMPLIED, INCLUDING BUT NOT LIMITED TO WARRANTY OF MERCHANTABILITY OR WARRANTY OF FITNESS FOR A PARTICULAR PURPOSE.

Graco's sole obligation and buyer's sole remedy for any breach of warranty shall be as set forth above. The buyer agrees that no other remedy (including, but not limited to, incidental or consequential damages for lost profits, lost sales, injury to person or property, or any other incidental or consequential loss) shall be available. Any action for breach of warranty must be brought within eight (8) years of the date of sale, or two (2) years for all other parts.

GRACO MAKES NO WARRANTY, AND DISCLAIMS ALL IMPLIED WARRANTIES OF MERCHANTABILITY AND FITNESS FOR A PARTICULAR PURPOSE, IN CONNECTION WITH ACCESSORIES, EQUIPMENT, MATERIALS OR COMPONENTS SOLD BUT NOT MANUFACTURED BY GRACO. These items sold, but not manufactured by Graco (such as electric motors, switches, hose, etc.), are subject to the warranty, if any, of their manufacturer. Graco will provide purchaser with reasonable assistance in making any claim for breach of these warranties.

In no event will Graco be liable for indirect, incidental, special or consequential damages resulting from Graco supplying equipment hereunder, or the furnishing, performance, or use of any products or other goods sold hereto, whether due to a breach of contract, breach of warranty, the negligence of Graco, or otherwise.

FOR GRACO CANADA CUSTOMERS

The Parties acknowledge that they have required that the present document, as well as all documents, notices and legal proceedings entered into, given or instituted pursuant hereto or relating directly or indirectly hereto, be drawn up in English. Les parties reconnaissent avoir convenu que la rédaction du présente document sera en Anglais, ainsi que tous documents, avis et procédures judiciaires exécutés, donnés ou intentés, à la suite de ou en rapport, directement ou indirectement, avec les procédures concernées.

Graco Information

For the latest information about Graco products, visit www.graco.com.

For patent information, see www.graco.com/patents.

TO PLACE AN ORDER, contact your Graco distributor or call to identify the nearest distributor.

Phone: 612-623-6928 or Toll Free: 1-800-533-9655, Fax: 612-378-3590

All written and visual data contained in this document reflects the latest product information available at the time of publication. Graco reserves the right to make changes at any time without notice.

Original instructions. This manual contains English. MM 3A5588

Graco Headquarters: Minneapolis

International Offices: Belgium, China, Japan, Korea

GRACO INC. AND SUBSIDIARIES • P.O. BOX 1441 • MINNEAPOLIS MN 55440-1441 • USA

Copyright 2018 Graco Inc. All Graco manufacturing locations are registered to ISO 9001.

www.graco.com

Revision L, September 2022