



DISPENSERS



PUMPS



METERS



NOZZLE



FILTRATION



FLUID MONITORING

# ST BOX



## FEATURES

- **STURDY STRUCTURE**
- **LOCKABLE AND SAFE**
- **READY TO USE**
- **FILTRATION GUARANTEED**
- **NOZZLE CONTACT (PRO VERSION ONLY)**

The PIUSI ST BOX is a diesel refueling station complete with pump, flow meter and filter, with lockable metal protection box. The unit is complete with antistatic hose for diesel fuel and automatic dispensing nozzle. The Pro version features the electronic access control box Access 85.

## PERFORMANCE

UP TO

**90 L/MIN**

FLOW-RATE

**AC**

**CONTINUOUS DUTY**

POWER

**± 1%**

ACCURACY



ST BOX PRO



ST BOX BASIC



## PACKAGING

CODE	WEIGHT		PACKAGING		
	KG	LBS	MM	INCH	PCS/BOX
<b>WITHOUT ACCESS 85</b>					
00036700B					
00036900B					
FO0365020					
FO0365060					
FO0365050	36	72	575X320X607	22,6X12,6X23,9	1
FO0365POA	40	88	575X320X607	22,6X12,6X23,9	1
FO039900A	50	110	590X340X720	23,2X13,4X28,3	1
<b>WITH ACCESS 85</b>					
FO0365010	40	88	575X320X607	22,6X12,6X23,9	1



HOSE REELS



ACCESSORIES



MERCHANDISE

## INDEX



AIR



ANTIFREEZE



AdBlue®



BIODIESEL



DIESEL



FOOD



GASOLINE



GREASE



KEROSENE



OIL



WATER



WINDSCREEN

## CHART

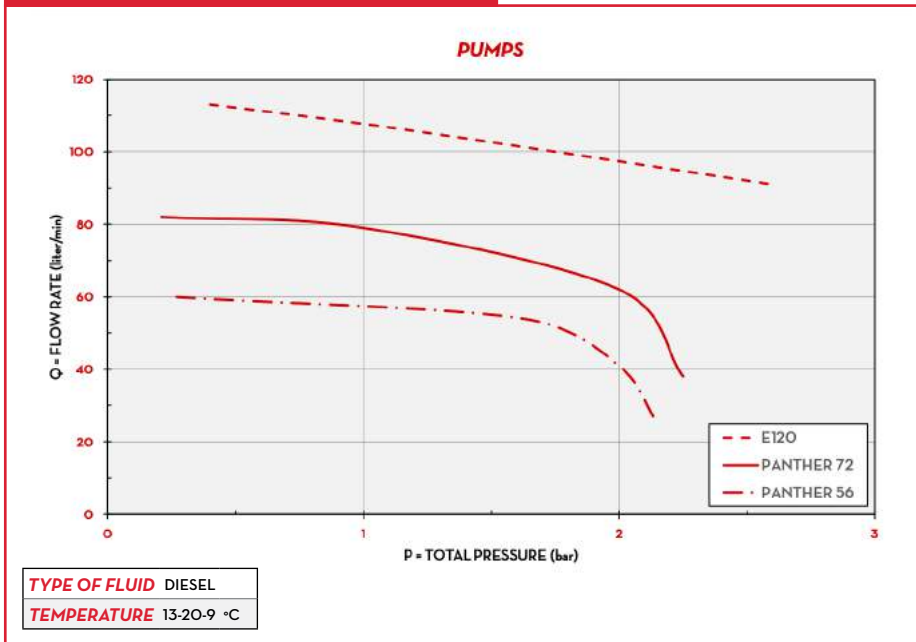

## IN THE BOX

- ST UNIT
- METER
- FILTER
- DELIVERY HOSE
- NOZZLE
- INSTRUCTION MANUAL

## DETAILS



K33 MECH. METER (pag. 108)



WATER CAPTOR FILTER (pag. 128)



DRIVER&amp;MANAGER KEY\*



ACCESS85 (pag. 142)

## DIMENSIONS

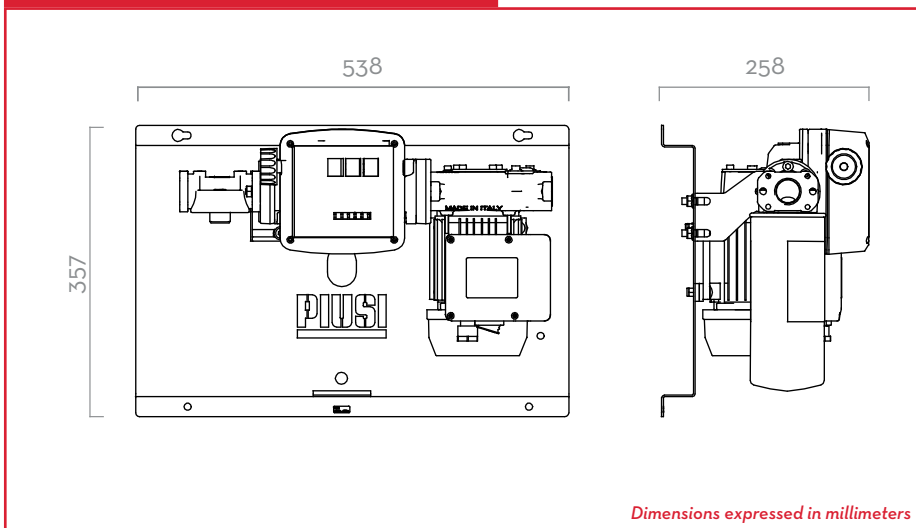

## COMPONENTS

- **PUMP:**
  - PANTHER AC PAG. 64
  - E80/E120 PAG. 68
  - BIPUMP PAG. 80
- **NOZZLE:**
  - AUTOMATIC NOZZLE PAG. 118
- **METER:**
  - K33 PAG. 108
  - K24 PAG. 94
- **FILTER**
  - WATER CAPTOR PAG. 128
- **ACCESSOCONTROL**
  - ACCESS85 PAG. 142

## TECHNICAL DATA

CODE	DESCRIPTION	FLUIDS TYPE	FLOW-RATE		VOLTAGE			PUMP TYPE	METER TYPE	NOZZLE TYPE	FILTER H2O FILTER	HOSE		INLET BSP
			L/MIN	GPM	AC V/HZ DC VOLT	POWER WATT	AMP. MAX.					LENGTH	Ø	
<b>WITHOUT ACCESS 85</b>														
00036700B	ST BOX E80/M K33 A80	D	80	21	230/50	500	3,5	E80	K33	AUT.	NO	4M	1"	1"
00036900B	ST BOX E120/M K33 A120	D	90	22	230/50	750	5,7	E120	K33	AUT.	NO	4M	1"	1"
FO0365020	ST BOX PANTHER 56 BASIC	D	56	15	230/50	350	3	PANTH. 56	K33	AUT.	YES	6M	1"	1"
FO0365060	ST BOX PANTHER 72 BASIC	D	70	19	230/50	500	4,2	PANTH. 72	K33	AUT.	YES	6M	1"	1"
FO0365050	ST BOX E 120 BASIC	D	90	22	230/50	750	5,7	E 120	K33	AUT.	YES	8M	1"	1"
FO0365POA	ST BOX P56/M K33 A60	D	56	15	230/50	350	3	PANTH. 56	K33	AUT.	NO	4M	3/4"	1"
FO039900A	ST BOX BI-PUMP 12V K33 A120	D	80	21	12	530	44	BIPUMP	K33	AUT.	NO	4M	1"	1"
<b>WITH ACCESS 85</b>														
FO0365010	ST BOX PANTHER 72 PRO	D	70	19	230/50	500	4,2	PANTH. 72	K24	AUT.	YES	6M	1"	1"

\*PRO VERSION ONLY