

Tank	
TANK CONTENTS	
DESIGNED TO	AS1940 / AS1692
BUILT TO	AS1657 / AS1554.1
PLATE THICKNESS, Material	4/4 mm, Q235B
Pressue Test	35KPA
External size	3916x2294x1270mm
Internal size	3808x2186x1058mm
GROSS VOLUME	8800L
SAFE FILL LEVEL	8000L
N. D. T.	Require By Client
TOTAL MASS	2188.74KG

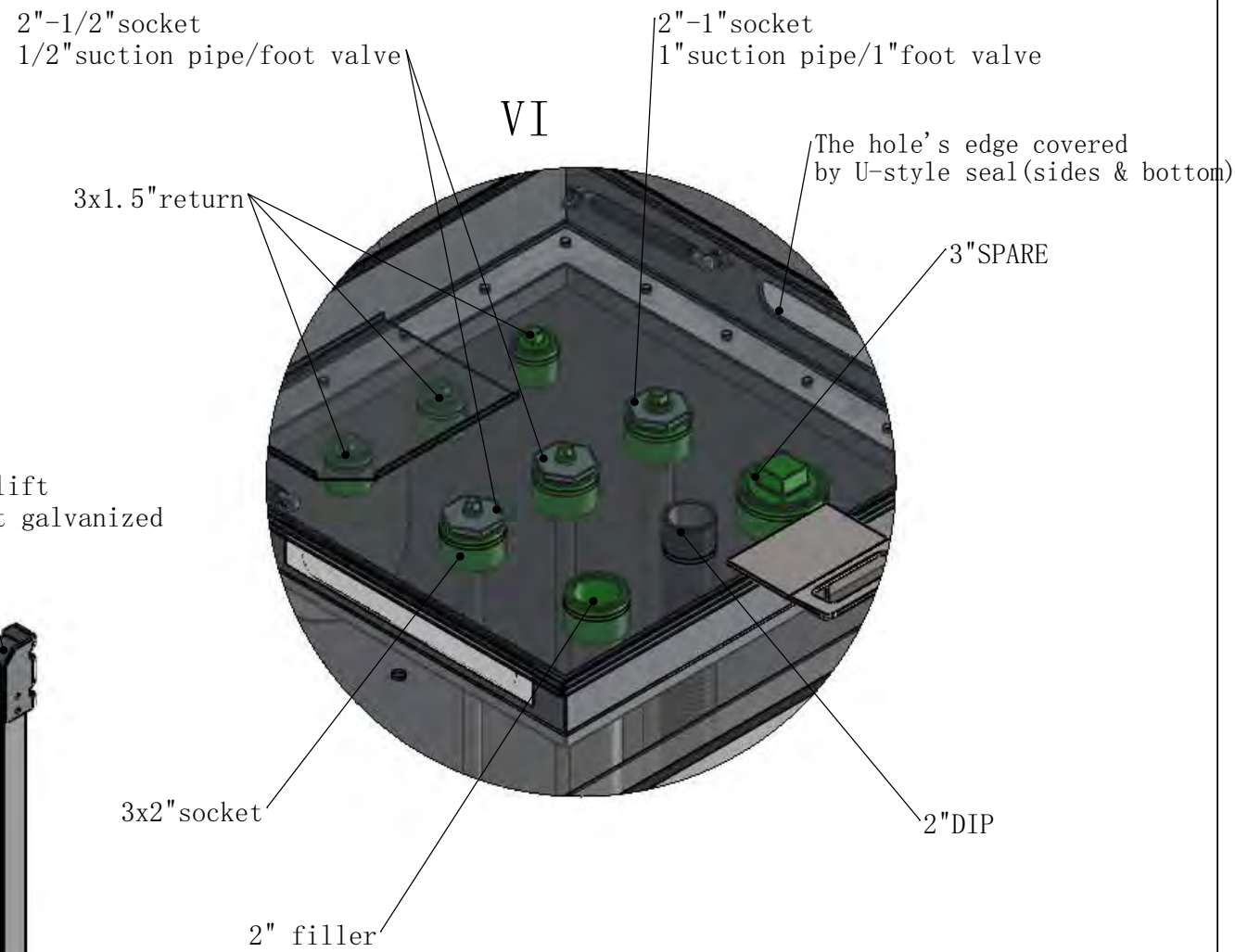

07					
06					
05					
04					
03					
02					
01					
REV:	DATE:	REVISION:	DRAWN:	CHECKED:	APPROVED:

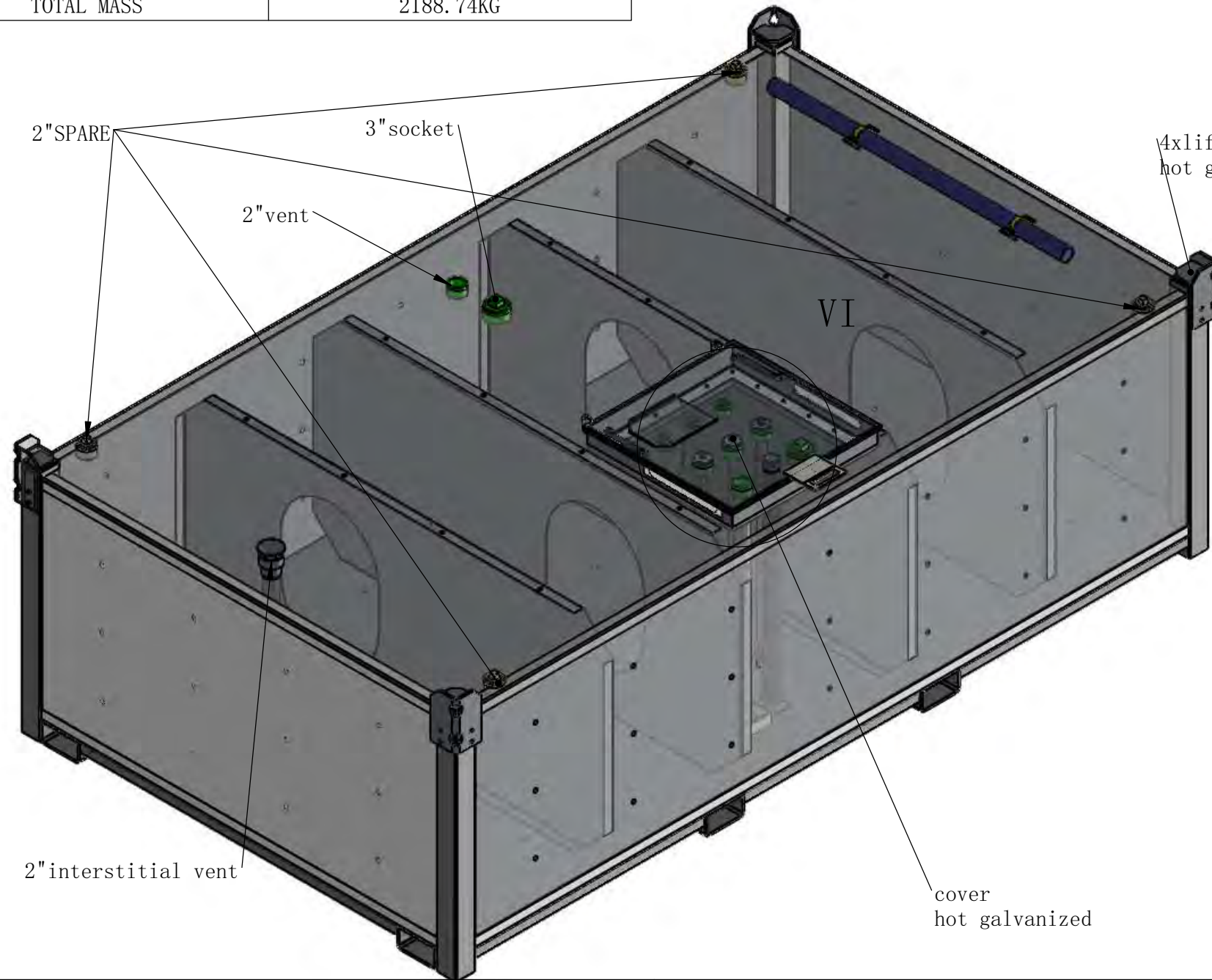

Material:
Weight: 2188.74KG

DRAWN:
DATE: 2020-07-02
CHECKED:
DATE:
CLIENT:
DATE:
APPROVED:
DATE:

TITLE:
BOX 8800L Self Bunded Tank
DRAWING NO. :
PURCHASE ORDER NO. :

REV: 01
SHEET: 1 of 4
Scale: No scale

A3



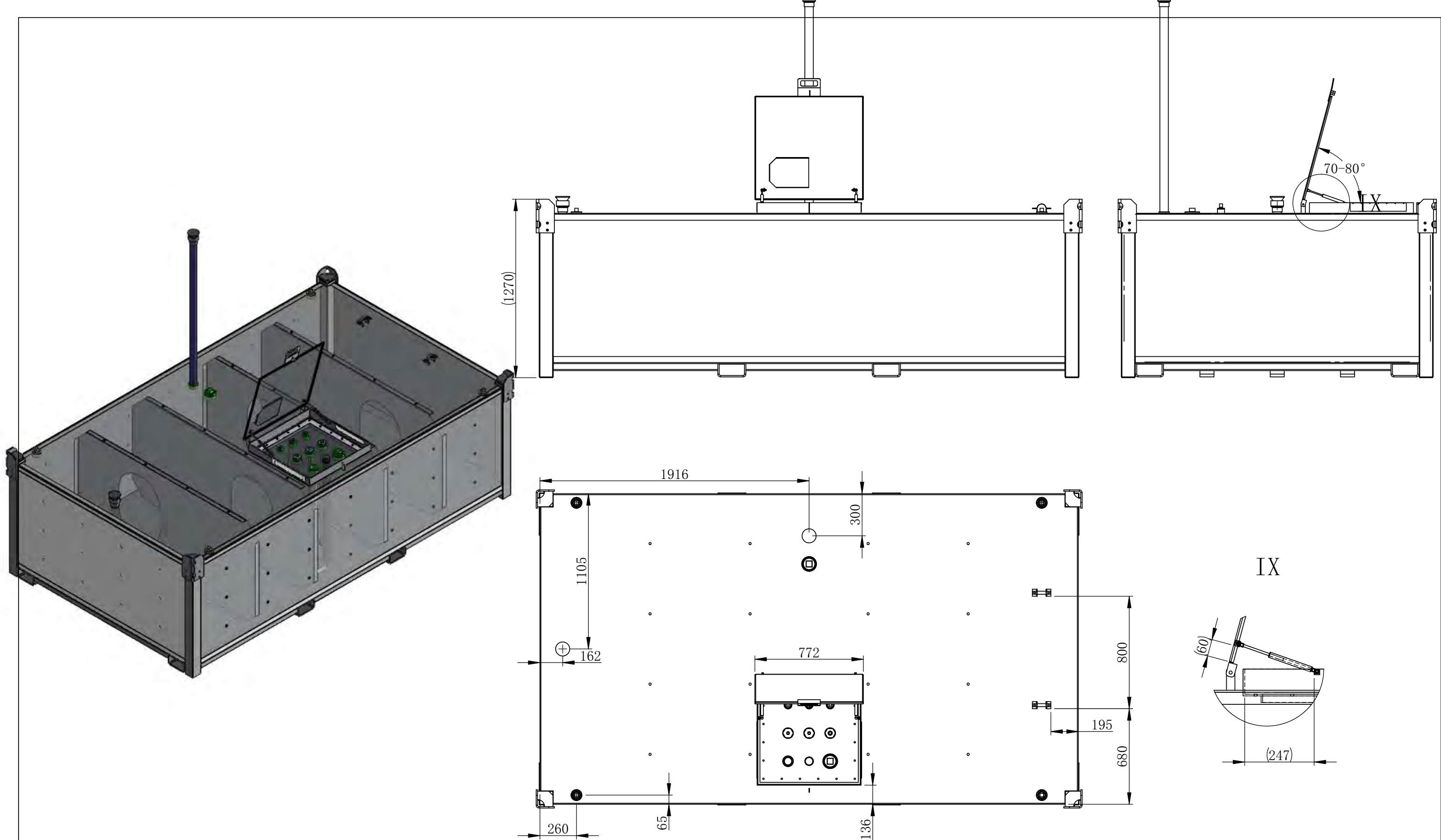

07					
06					
05					
04					
03					
02					
01					
REV:	DATE:	REVISION:	DRAWN:	CHECKED:	APPROVED:



Material:
Weight: 2188.74KG

DRAWN: DATE: 2020-07-02
 CHECKED: DATE:
 CLIENT: DATE:
 APPROVED: DATE:

TITLE:
 BOX 8800L Self Bunded Tank
 DRAWING NO. :
 PURCHASE ORDER NO. :

REV: 01
 SHEET: 2 of 4
 Scale: No scale

A3



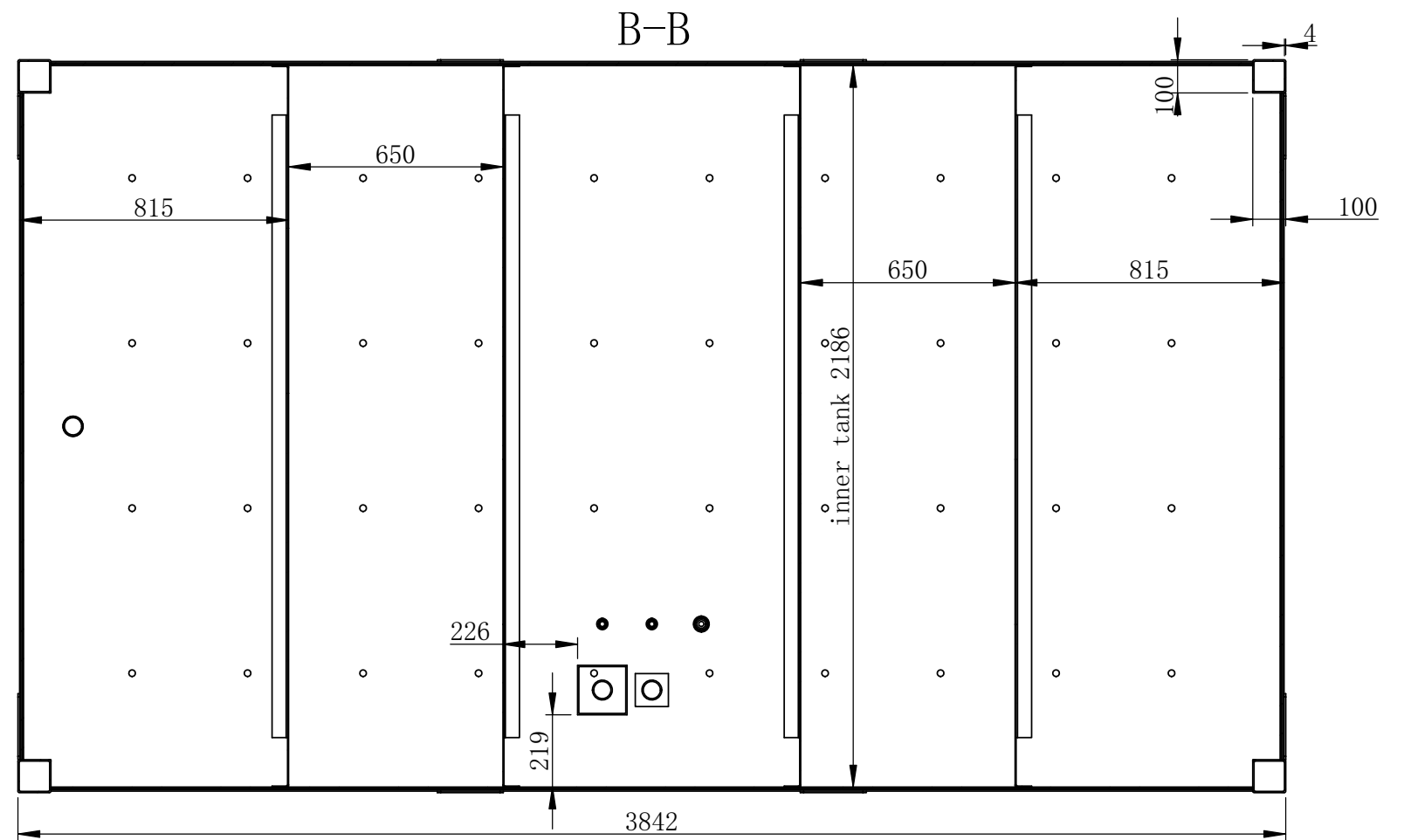
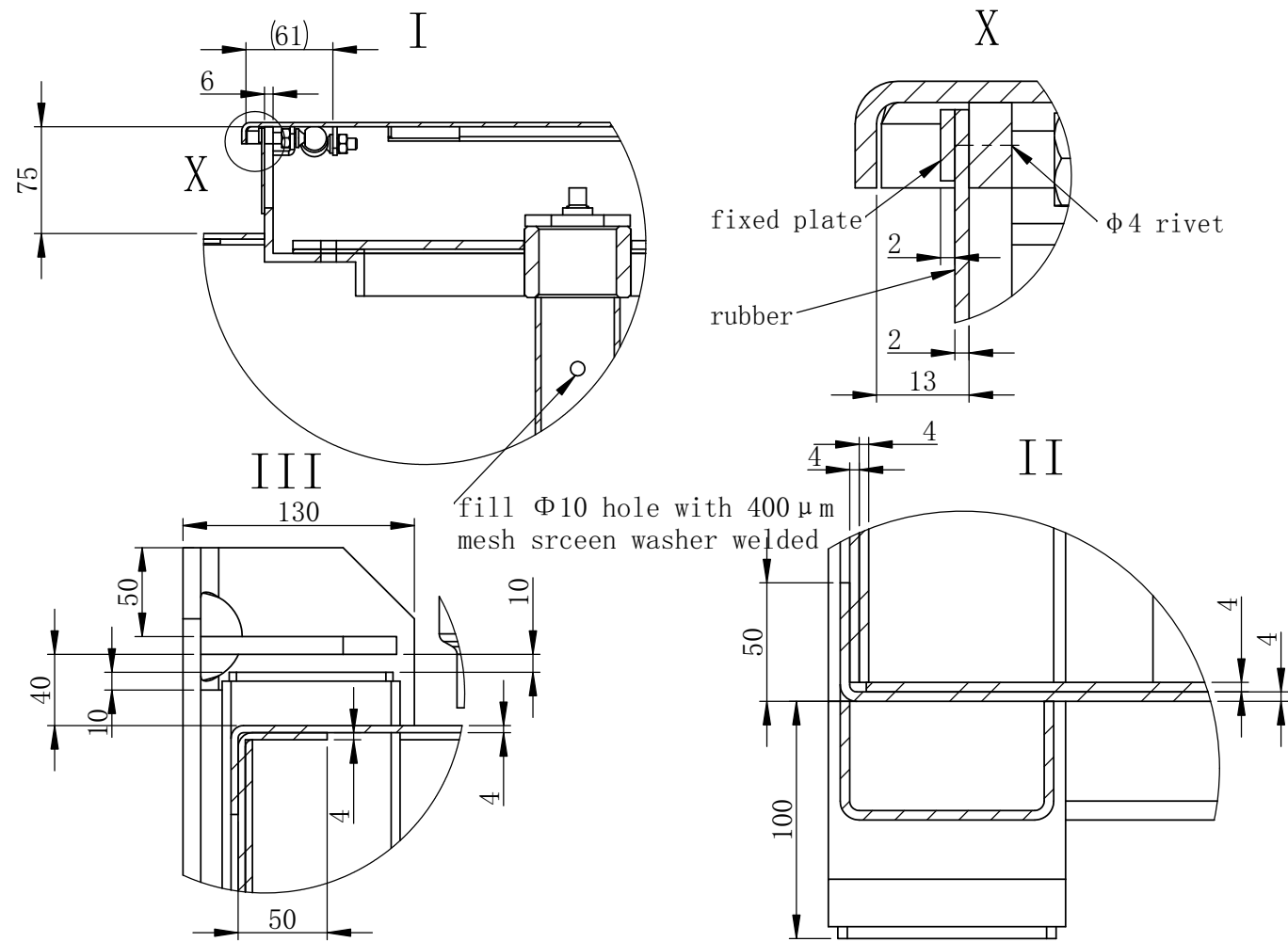
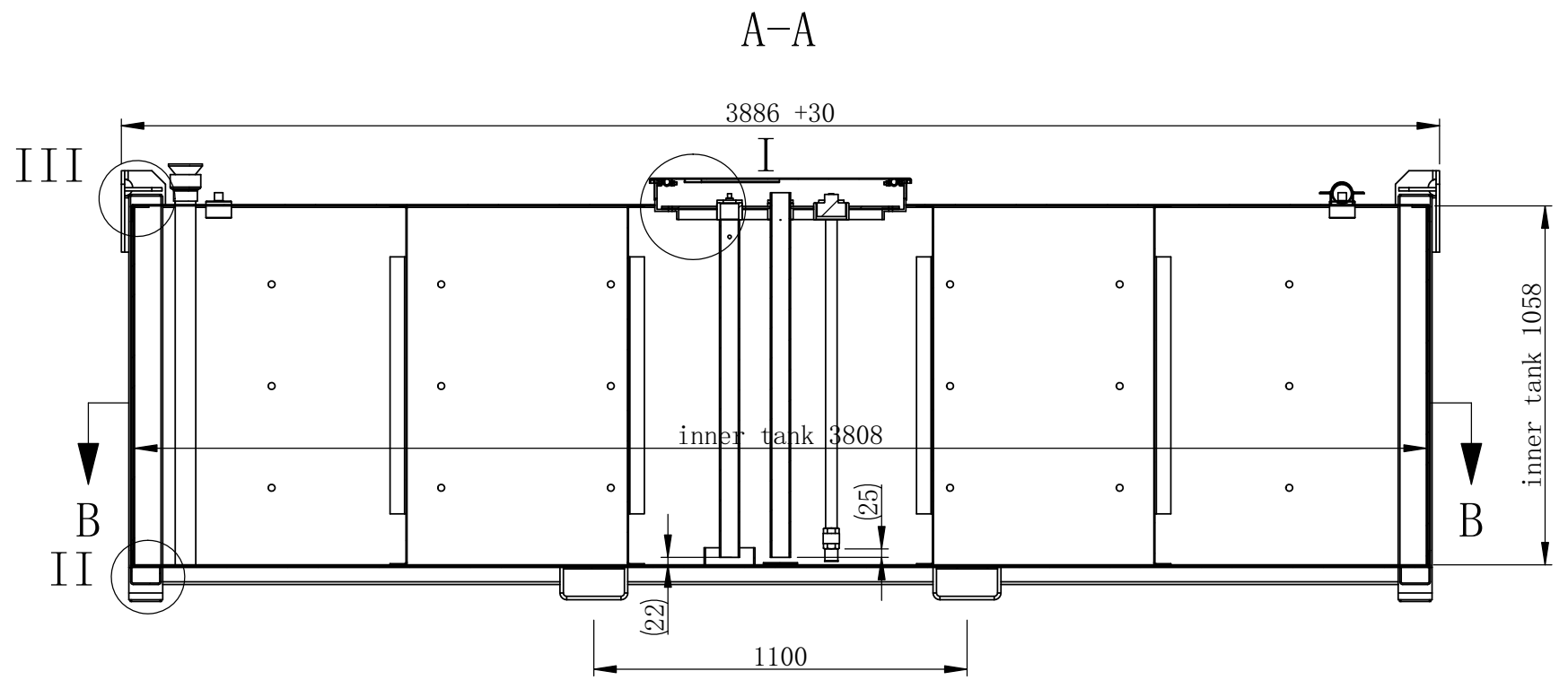
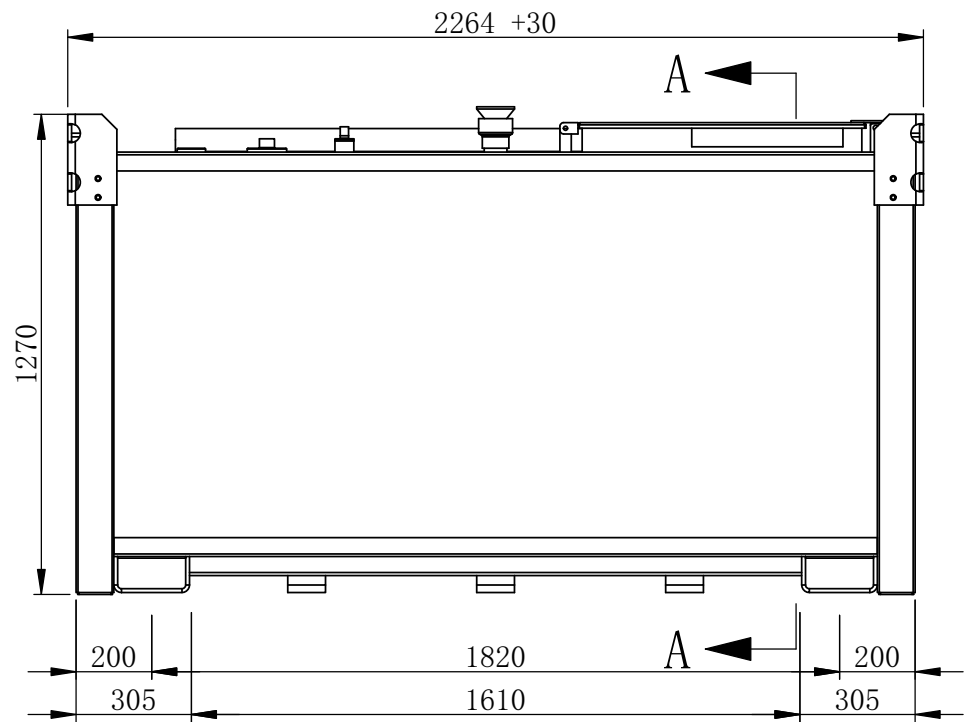

07					
06					
05					
04					
03					
02					
01					
REV:	DATE:	REVISION:	DRAWN:	CHECKED:	APPROVED:



Material:
Weight: 2188.74KG

DRAWN: DATE: 2020-07-02
CHECKED: DATE:
CLIENT: DATE:
APPROVED: DATE:

TITLE:
BOX 8800L Self Bunded Tank
DRAWING NO. :
PURCHASE ORDER NO. :

REV: 01
SHEET: 3 of 4
Scale: No scale

A3



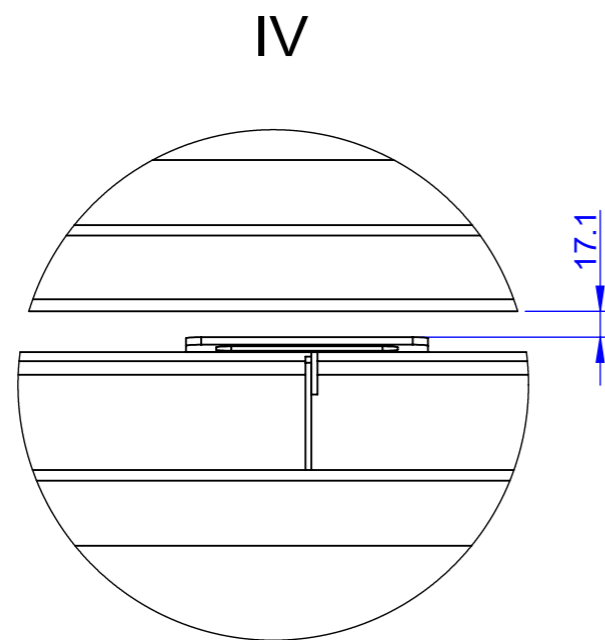
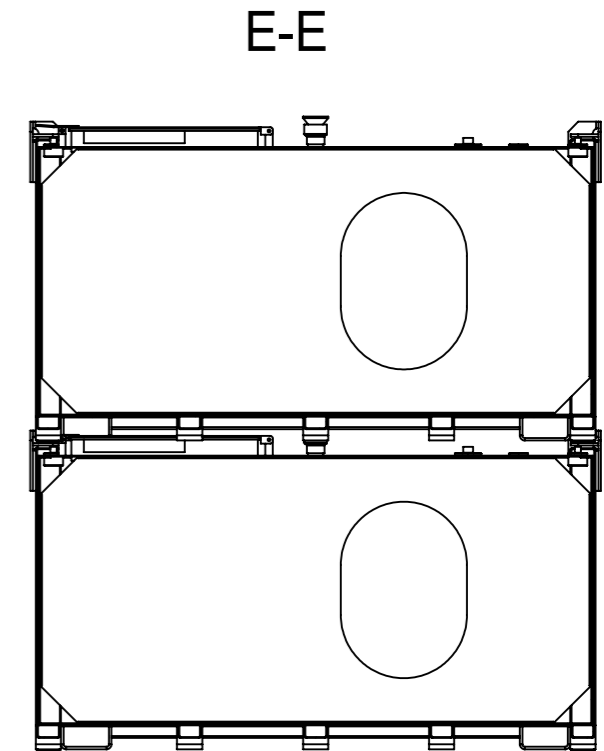
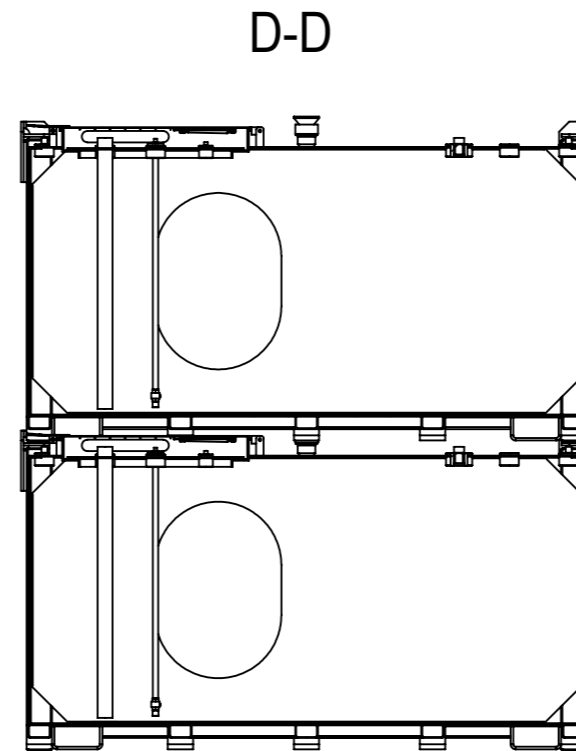
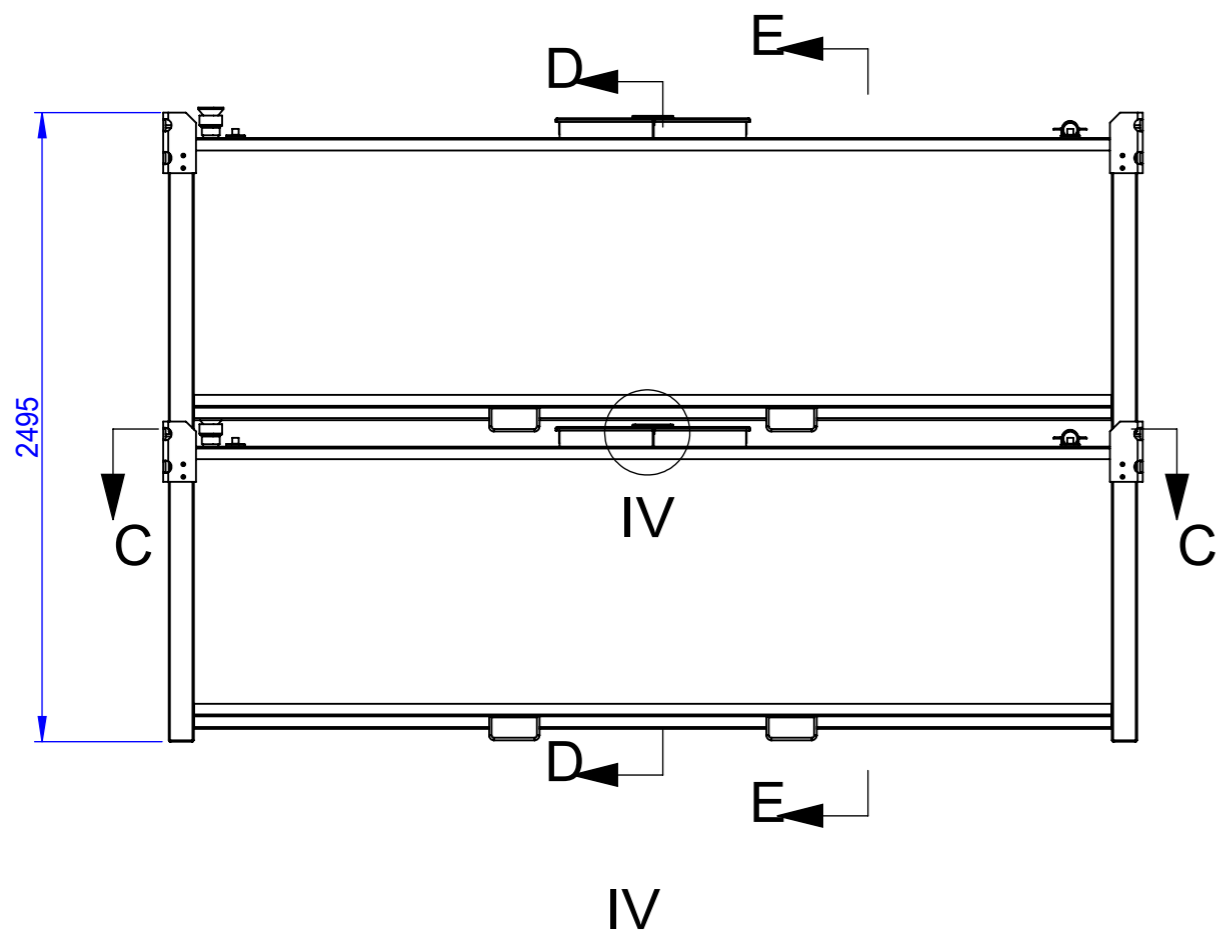

C-C

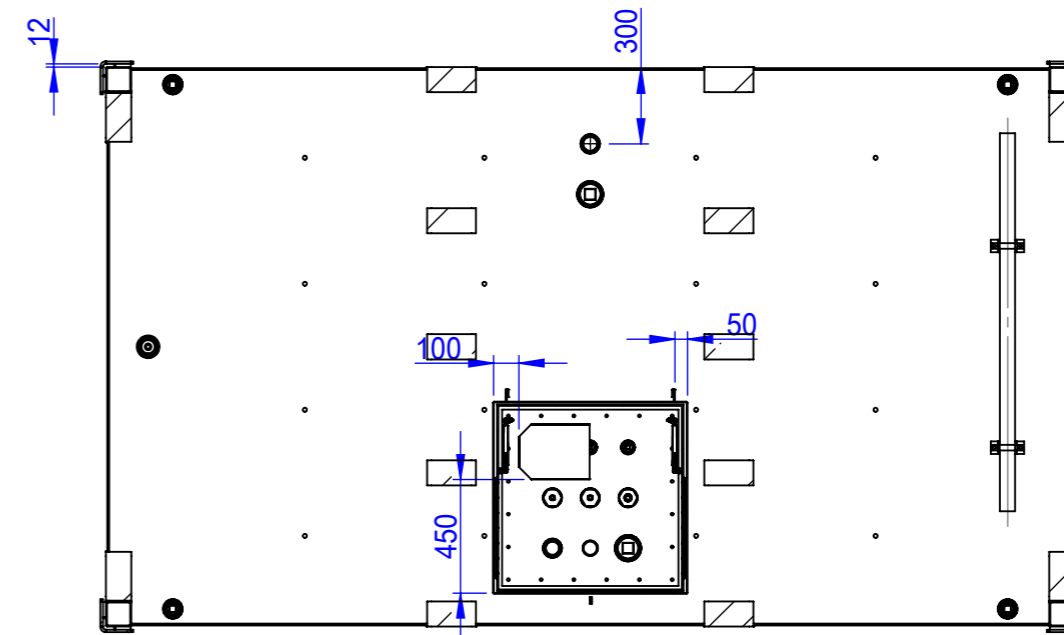

07					
06					
05					
04					
03					
02					
01					
REV:	DATE:	REVISION:	DRAWN:	CHECKED:	APPROVED:



Material:
Weight: 4373.92KG

DRAWN:
DATE: 2020/5/15
CHECKED:
DATE:
CLIENT:
DATE:
APPROVED:
DATE:

TITLE:
BOX 8800L Self Bunded Tank

DRAWING NO. :

PURCHASE
ORDER NO. :

REV:
01
SHEET:
4 of 4

Scale:
No scale

A3

