

Tank	
TANK CONTENTS	
DESIGNED TO	AS1940 / AS1692
BUILT TO	AS1657 / AS1554.1
PLATE THICKNESS, Material	4/4 mm, Q235B
Pressue Test	35KPA
External size	2294x1546x1270mm
Internal size	2186x1438x1058mm
GROSS VOLUME	3300L
SAFE FILL LEVEL	3000L
N. D. T.	Require By Client
TOTAL MASS	1092.54KG

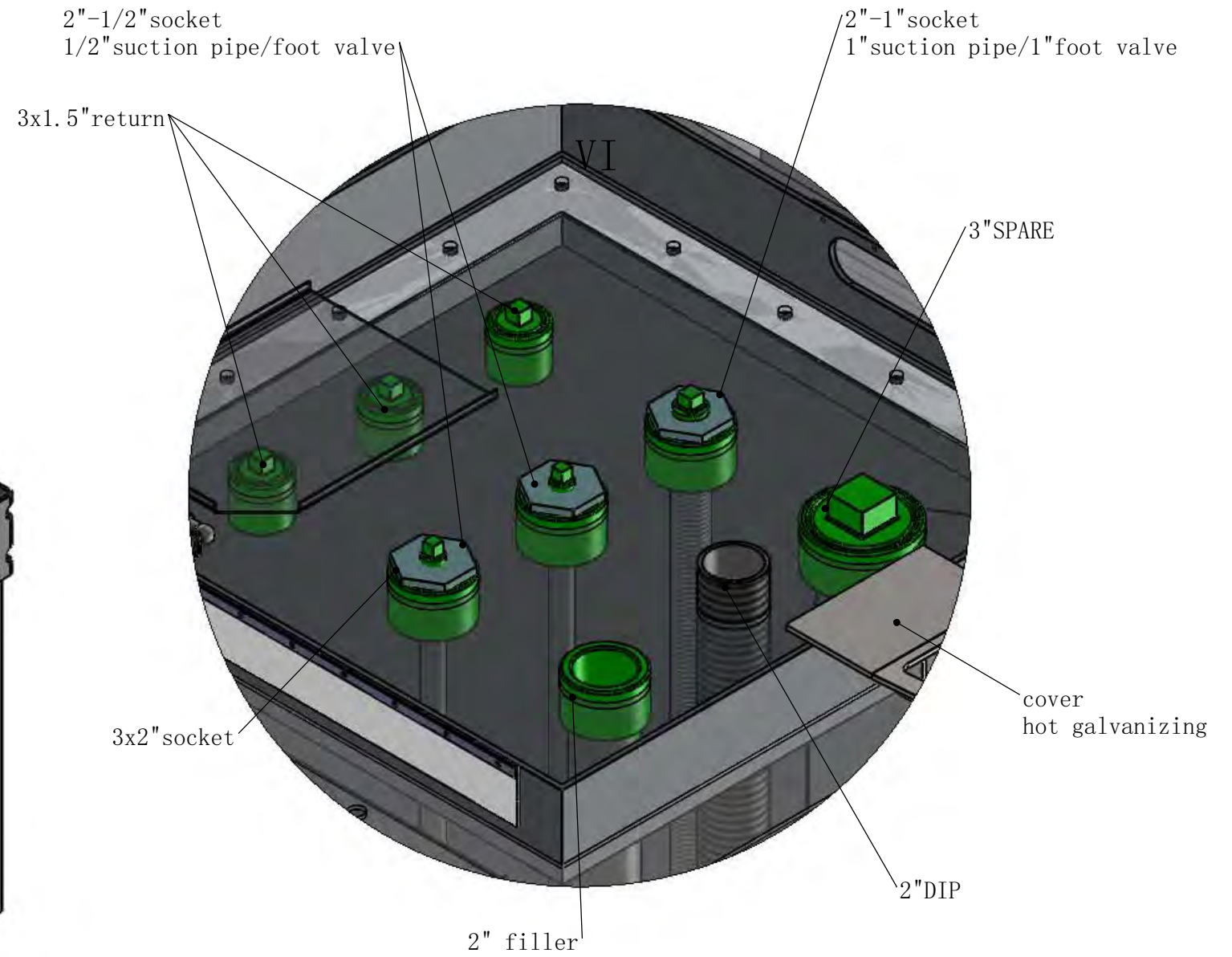

07					
06					
05					
04					
03					
02					
01					
REV:	DATE:	REVISION:	DRAWN:	CHECKED:	APPROVED:

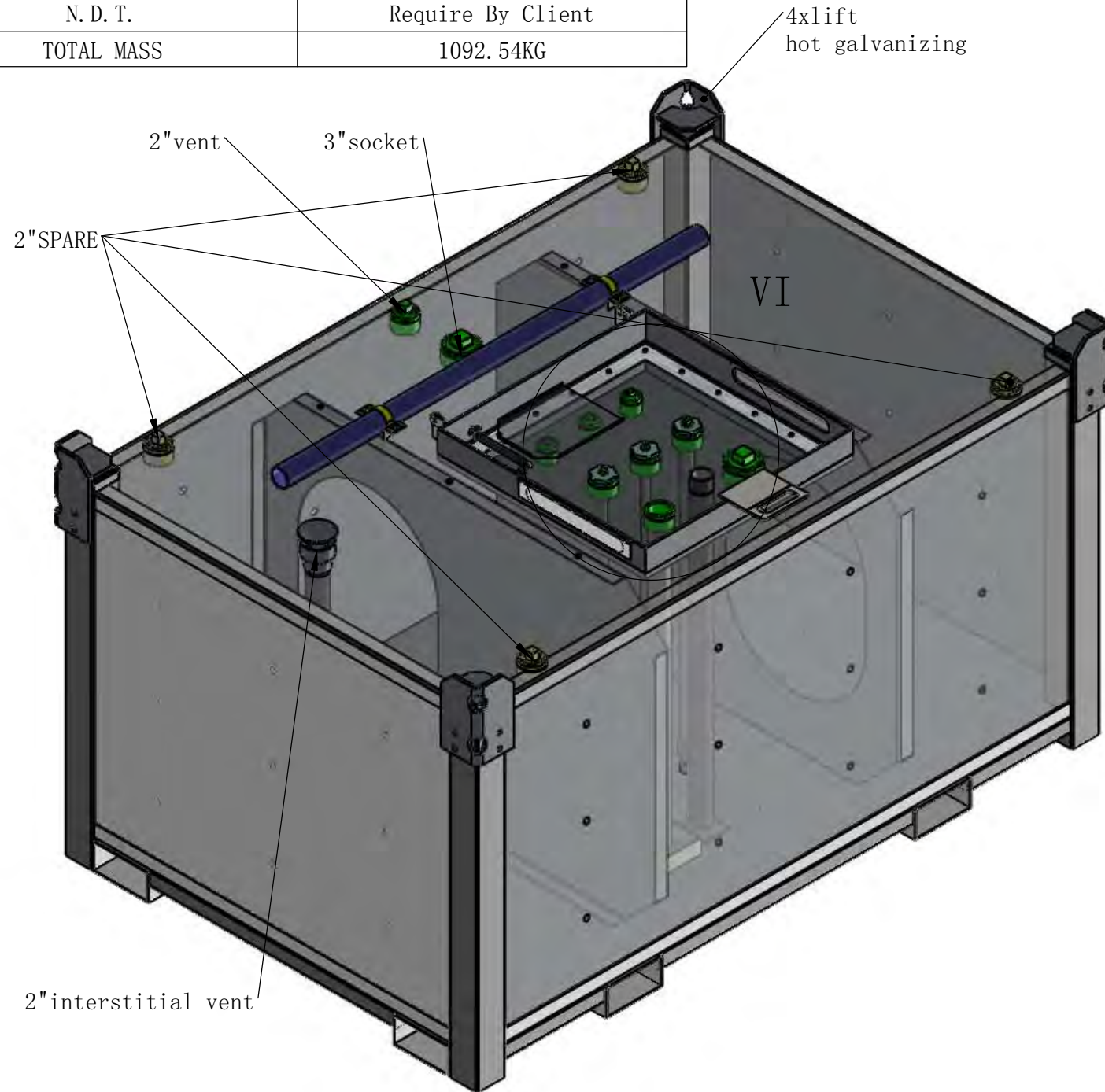

Material:
Weight: 1092.54KG

DRAWN:
DATE: 2020-07-01
CHECKED:
DATE:
CLIENT:
DATE:
APPROVED:
DATE:

TITLE:
BOX 3300L Self Bunded Tank
DRAWING NO. :
PURCHASE ORDER NO. :

REV: 01
SHEET: 1 of 4
Scale: No scale

A3



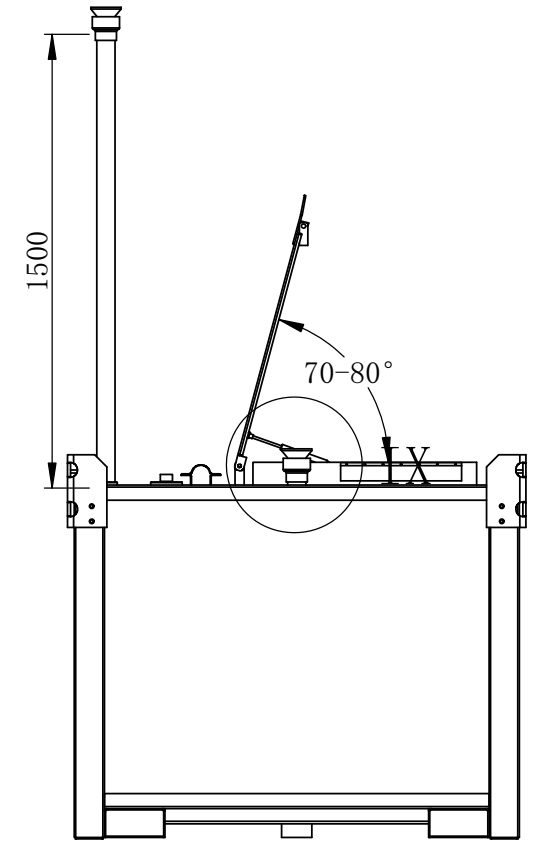
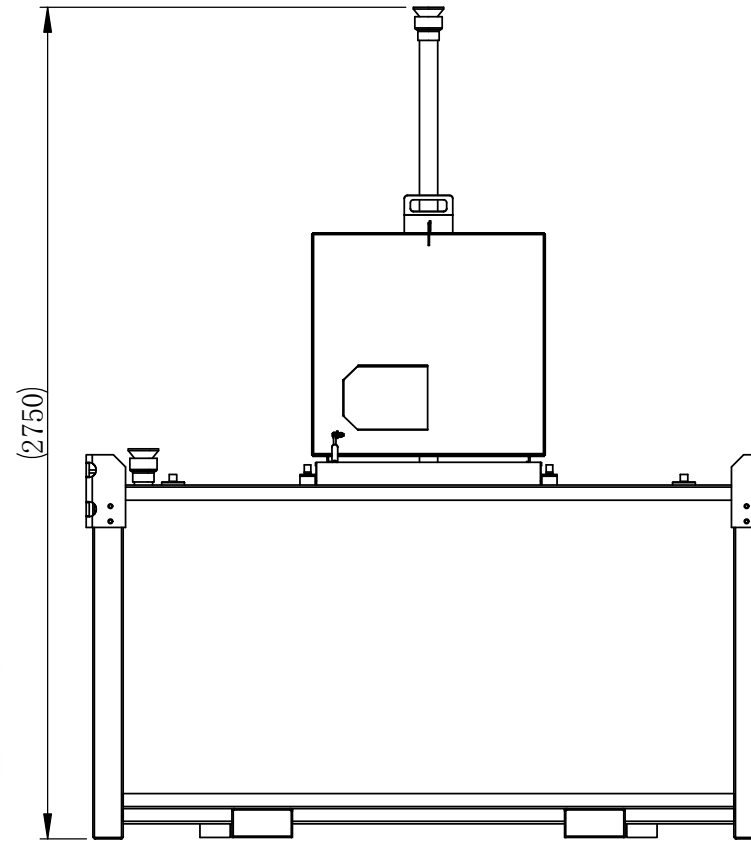
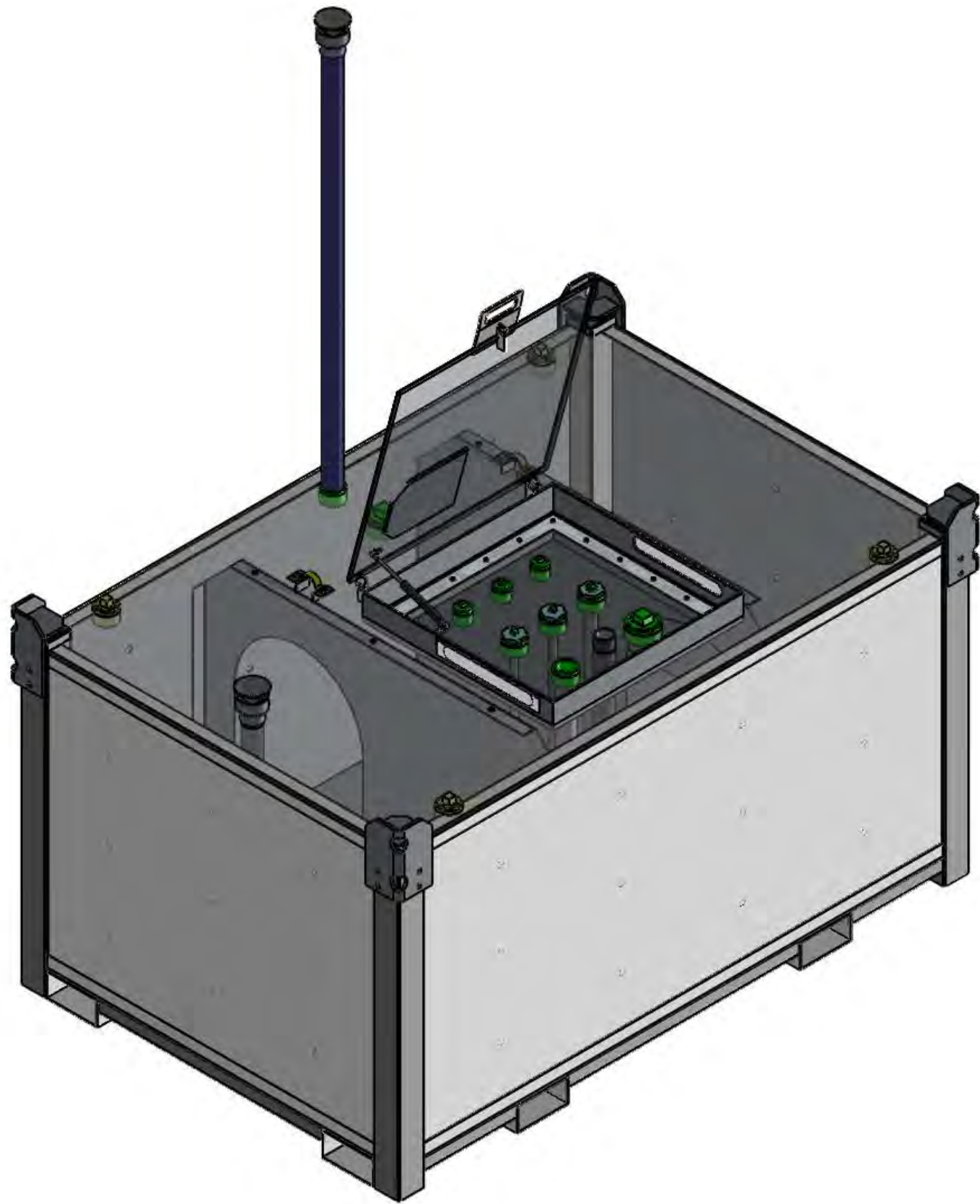

IX

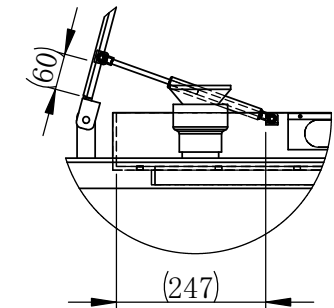
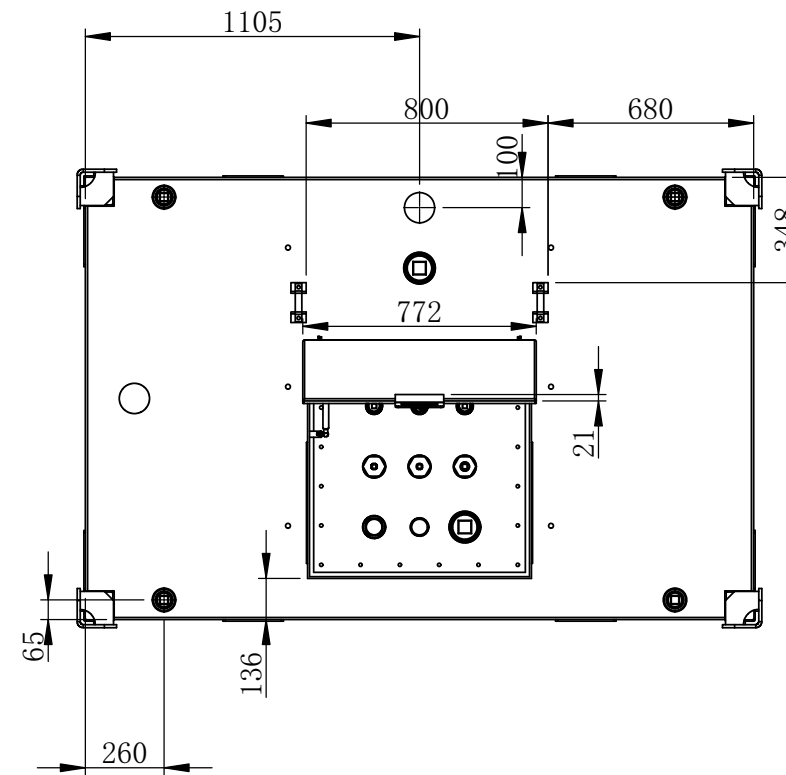

07					
06					
05					
04					
03					
02					
01					
REV:	DATE:	REVISION:	DRAWN:	CHECKED:	APPROVED:



Material:
Weight: 1092.54KG

DRAWN:
DATE: 2020-07-01
CHECKED:
DATE:
CLIENT:
DATE:
APPROVED:
DATE:

TITLE:
BOX 3300L Self Bunded Tank

DRAWING NO. :

PURCHASE
ORDER NO. :

REV:
01
SHEET:
2 of 4
Scale:
No scale

A3



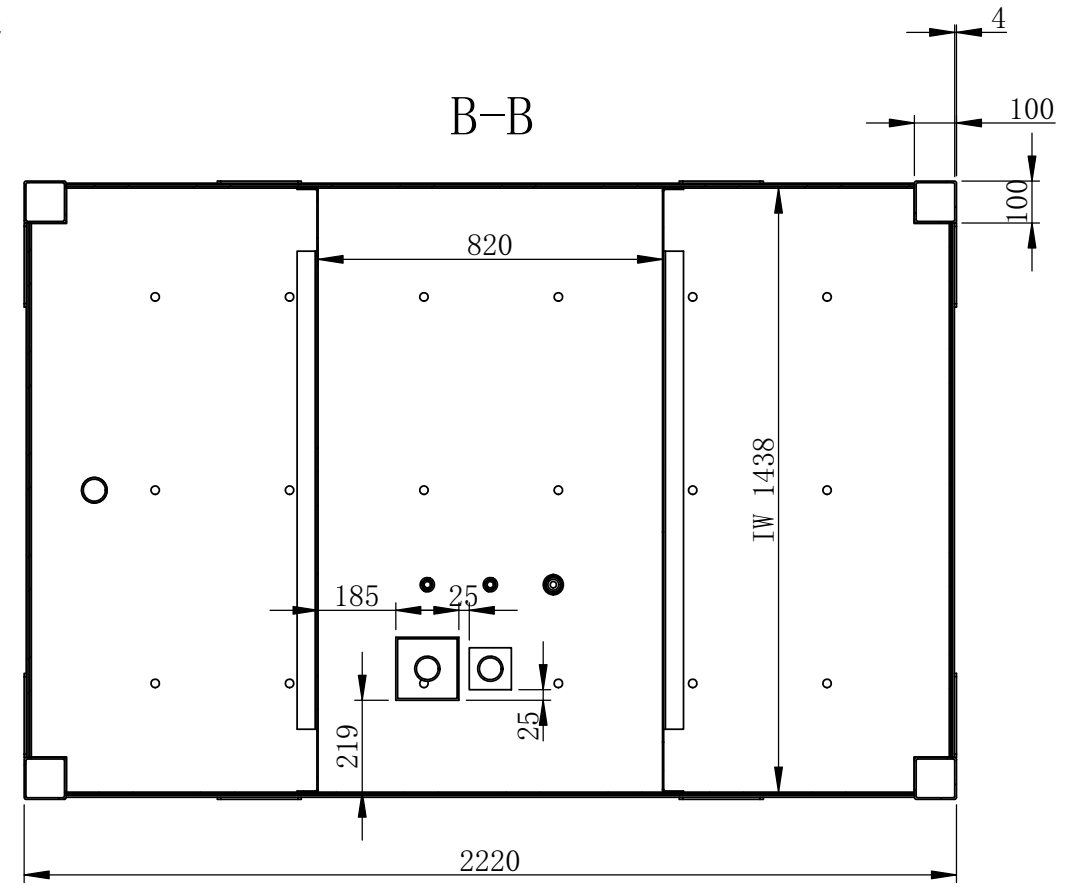
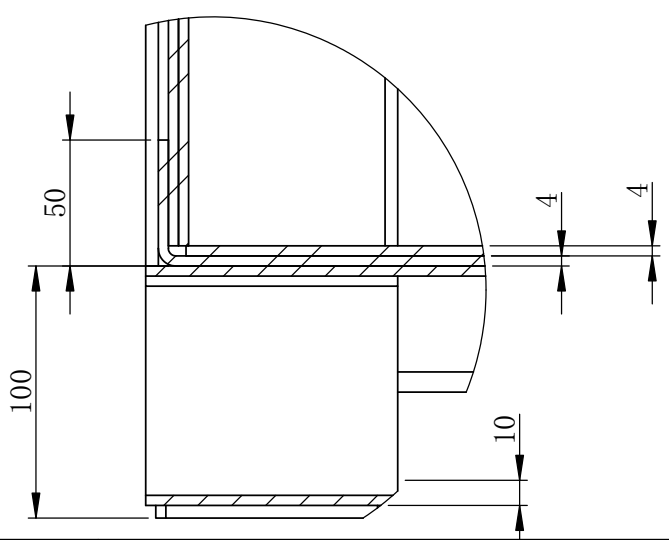
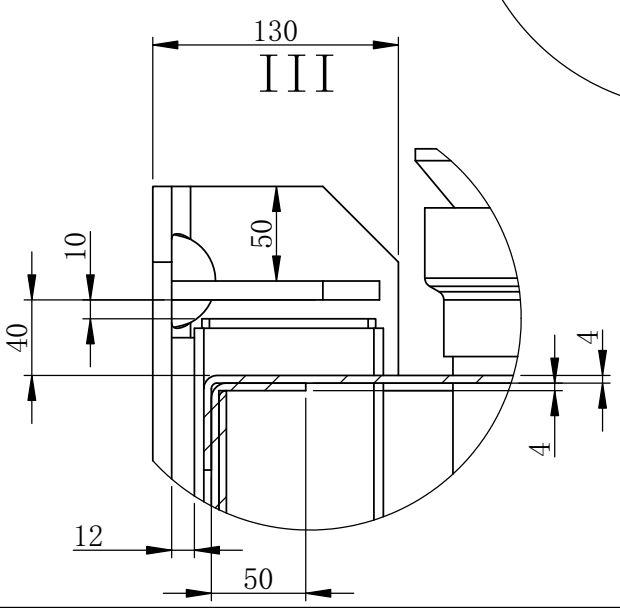
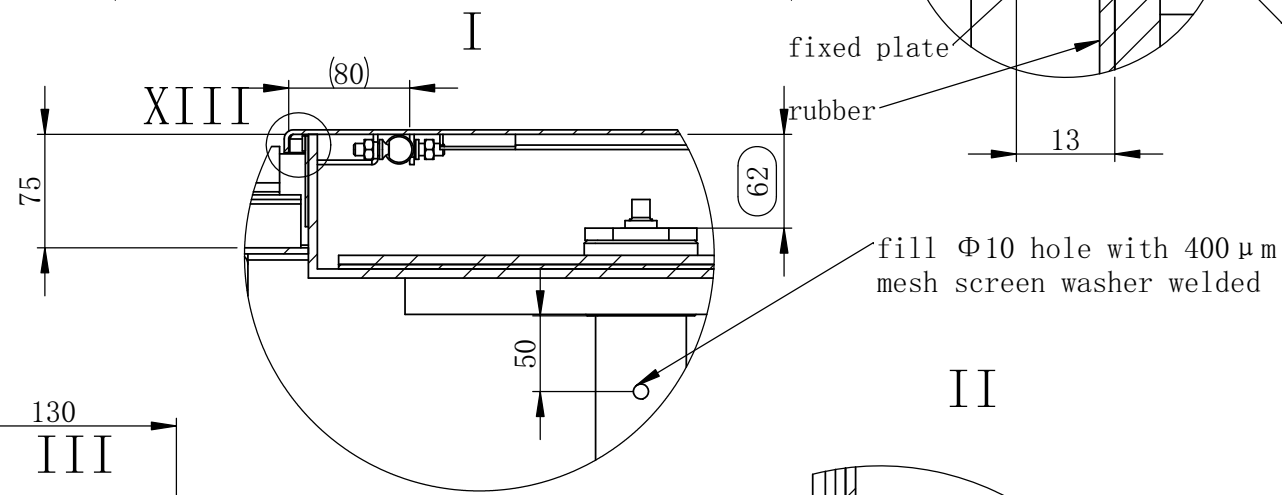
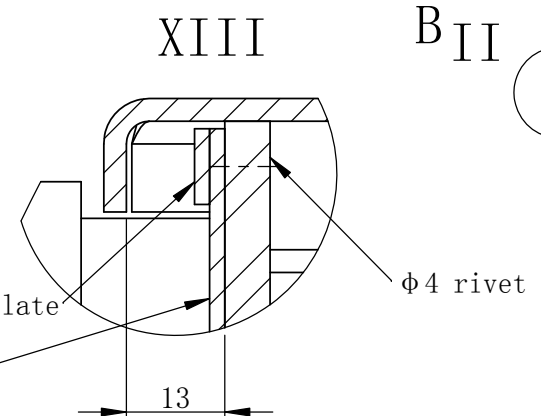
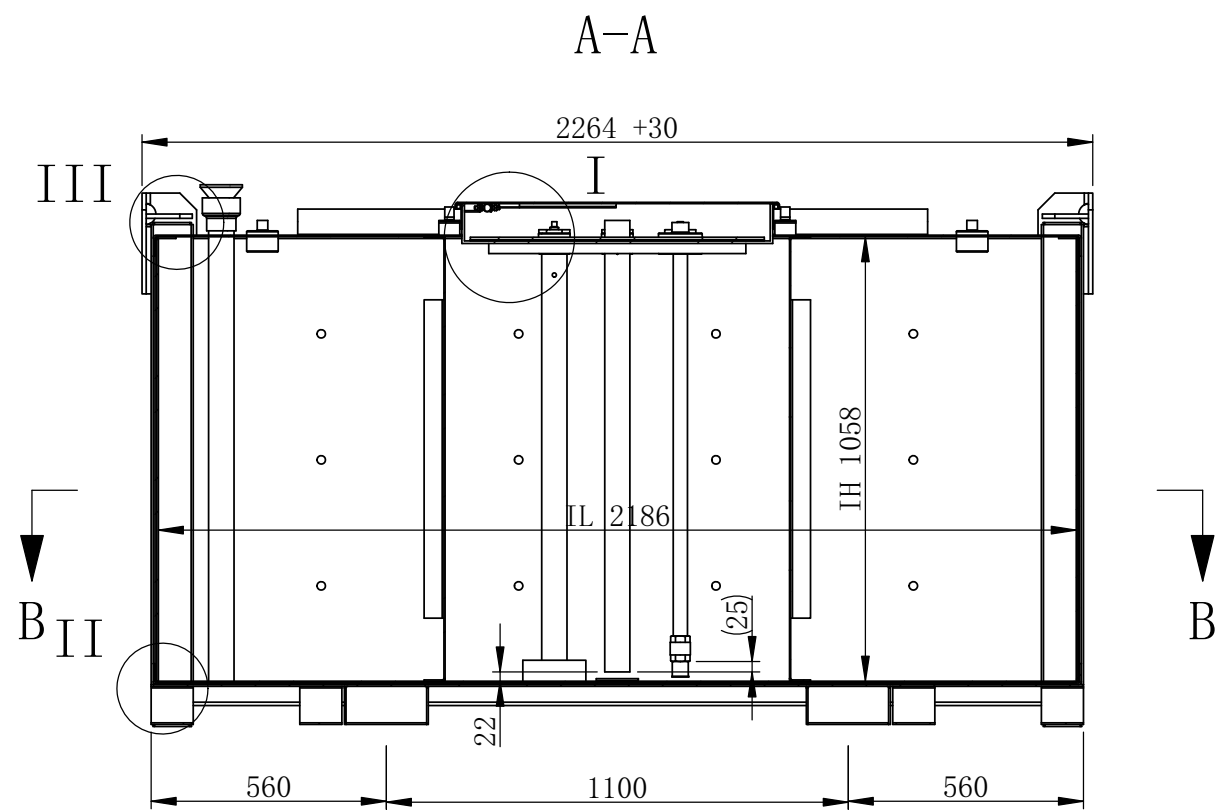
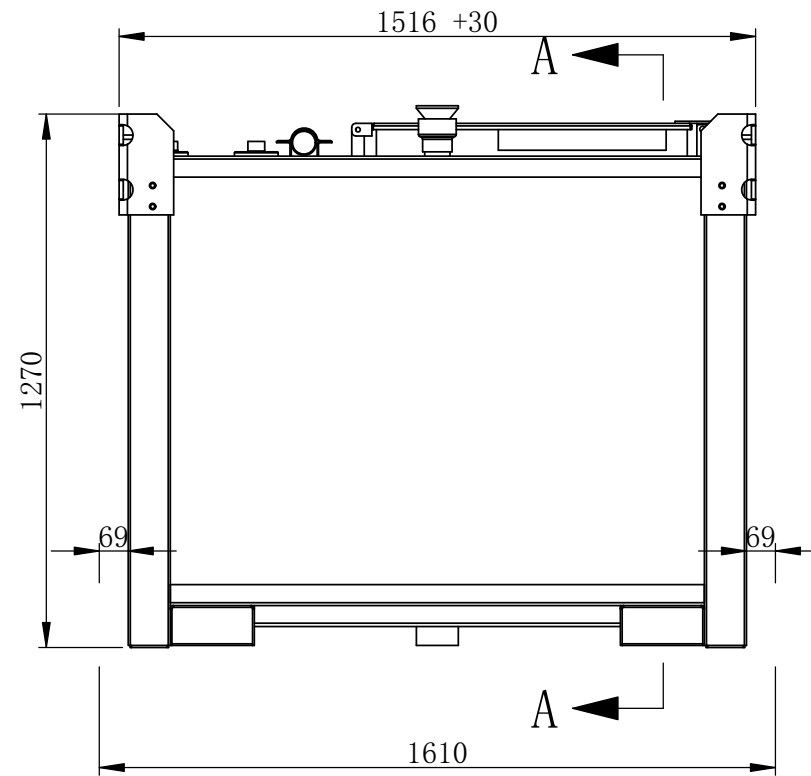

07					
06					
05					
04					
03					
02					
01					
REV:	DATE:	REVISION:	DRAWN:	CHECKED:	APPROVED:



Material:
Weight: 1094.29KG

DRAWN:	DATE:
CHECKED:	DATE:
CLIENT:	DATE:
APPROVED:	DATE:

TITLE:
BOX 3300L Self Bunded Tank

DRAWING NO. :

PURCHASE ORDER NO. :

REV:
01
SHEET:
3 of 4
Scale:
No scale

A3



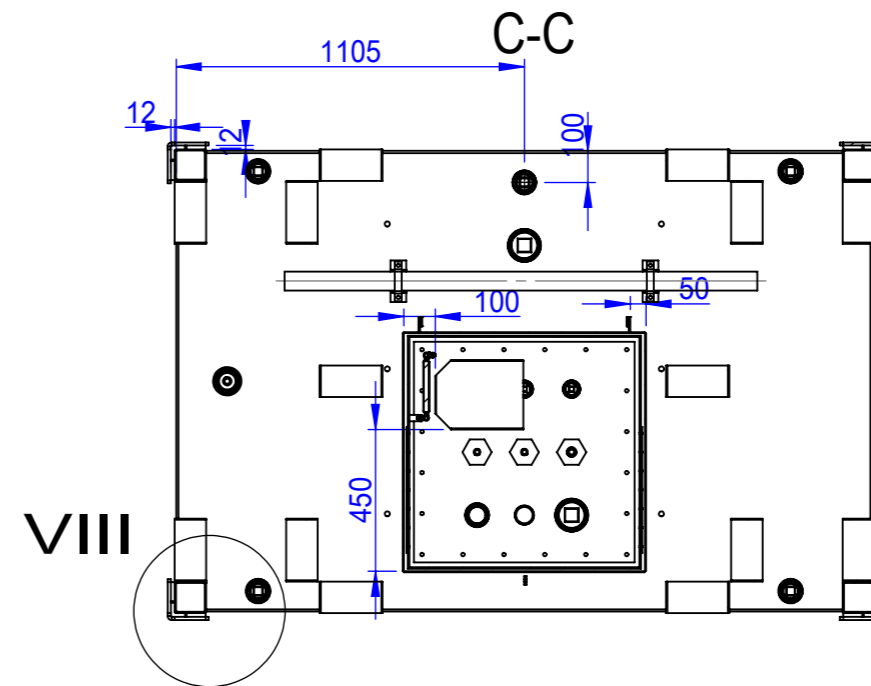
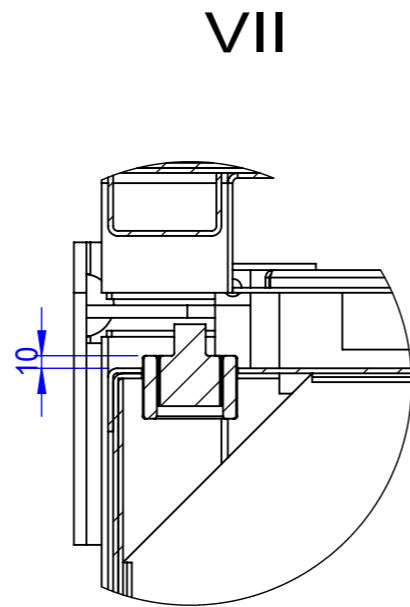
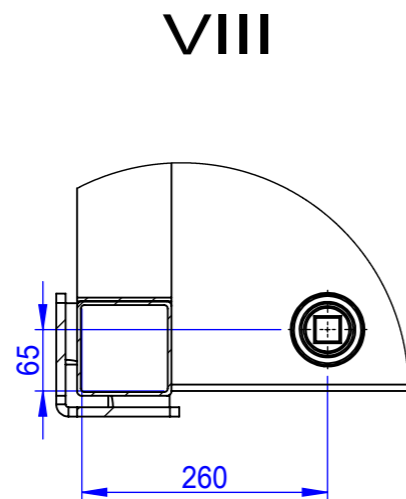
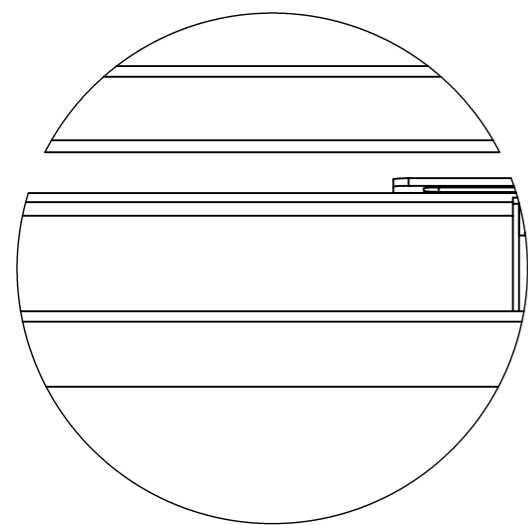
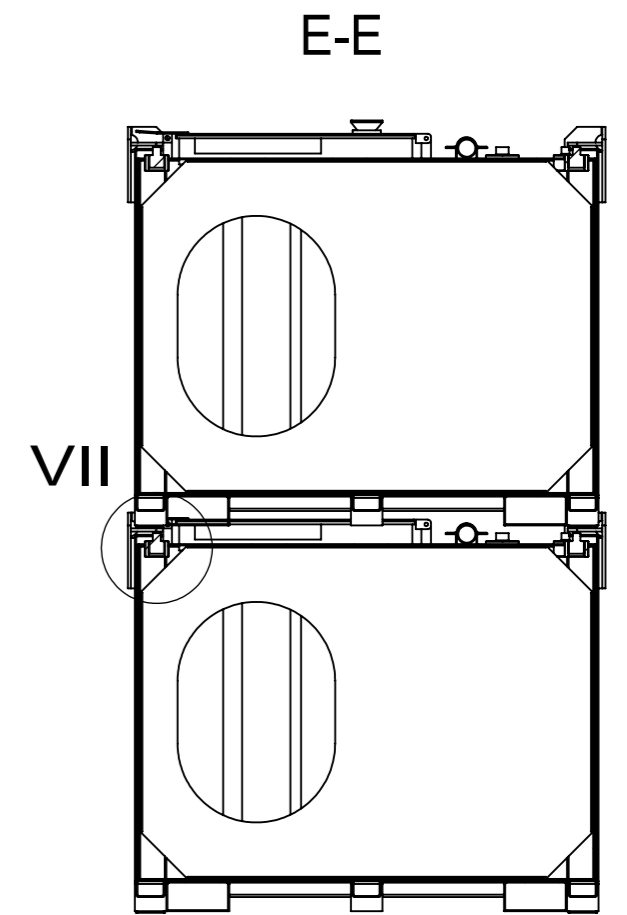
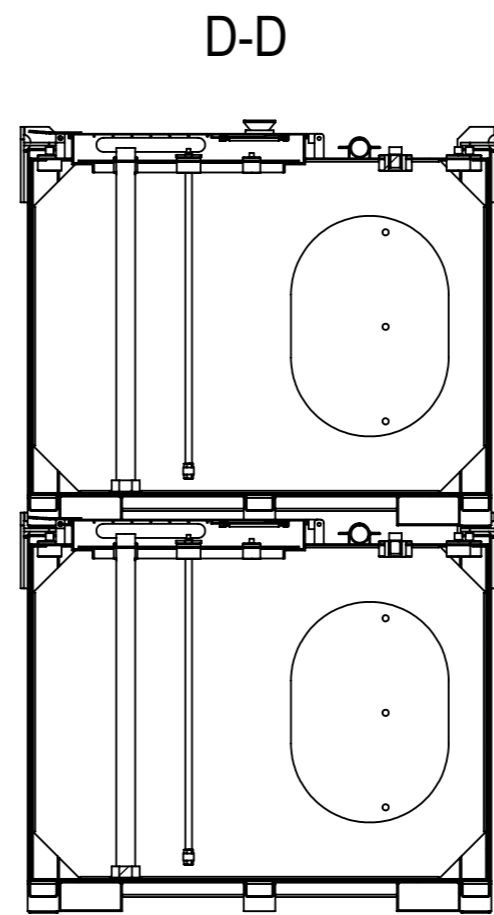
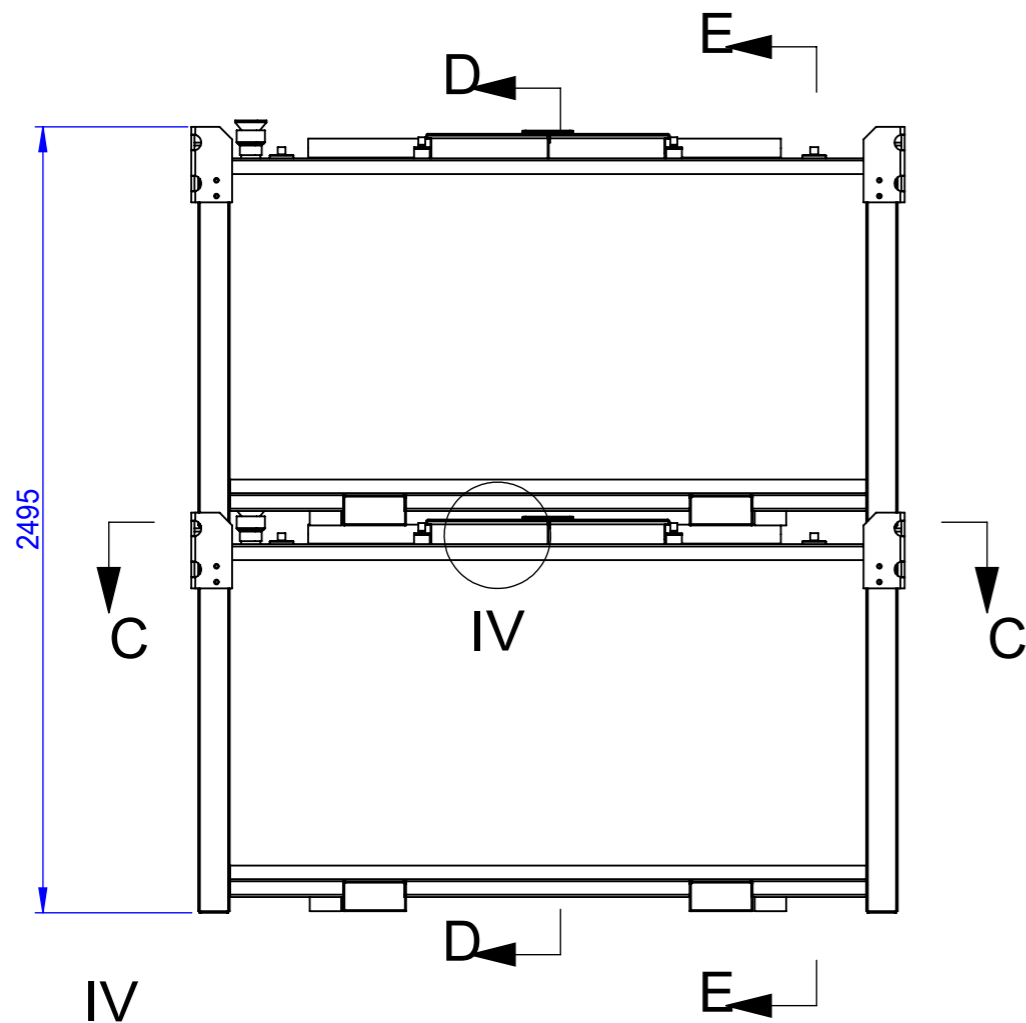

07					
06					
05					
04					
03					
02					
01					
REV:	DATE:	REVISION:	DRAWN:	CHECKED:	APPROVED:



Material:
Weight: 2172.40KG

DRAWN:
CHECKED:
CLIENT:
APPROVED:

DATE:
2019/7/5
DATE:
DATE:
DATE:

TITLE:
BOX 3300L Self Bunded Tank
DRAWING NO. :
PURCHASE ORDER NO. :

REV:
01
SHEET:
4 of 4
Scale:
No scale

A3

