

Tank	
TANK CONTENTS	
DESIGNED TO	AS1940 / AS1692
BUILT TO	AS1657 / AS1554.1
PLATE THICKNESS, Material	4/4 mm, Q235B
Pressue Test	35KPA
External size	2294x1086x1270mm
Internal size	2186x978x1058mm
GROSS VOLUME	2250L
SAFE FILL LEVEL	2000L
N. D. T.	Require By Client
TOTAL MASS	887.62KG

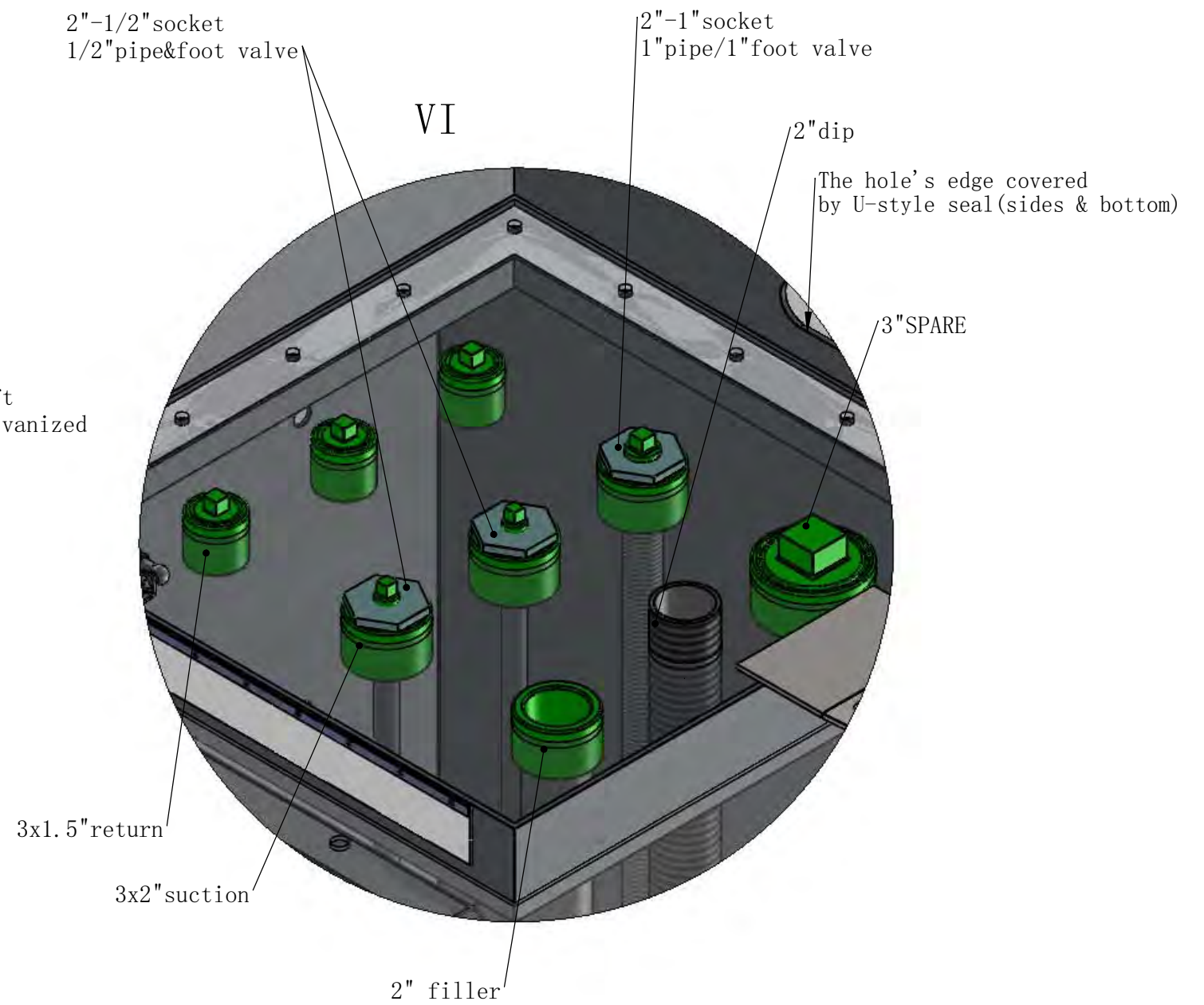

07					
06					
05					
04					
03					
02					
01					
REV:	DATE:	REVISION:	DRAWN:	CHECKED:	APPROVED:

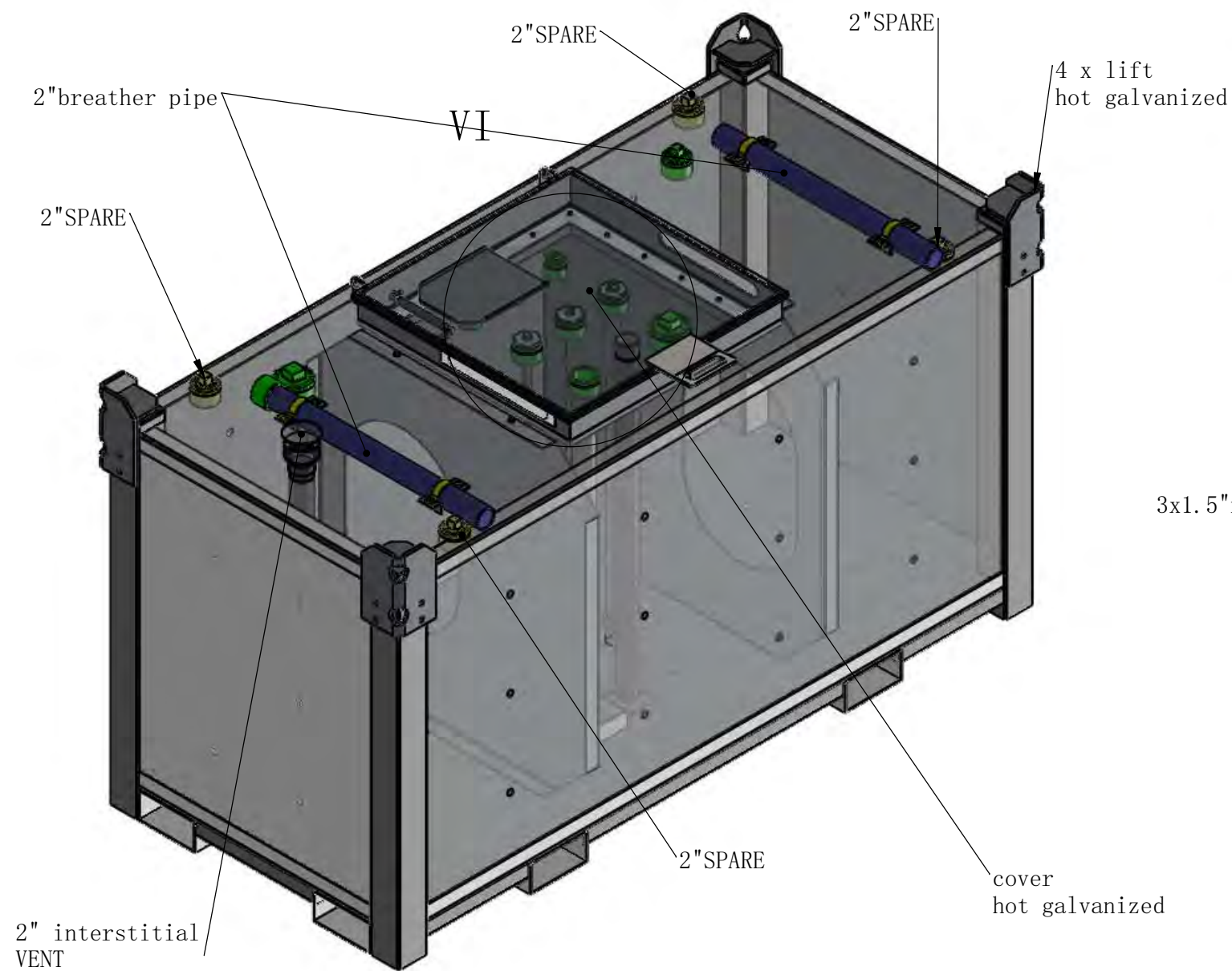

Material:  
Weight: 887.62KG

DRAWN: DATE: 2020-06-29  
CHECKED: DATE:  
CLIENT: DATE:  
APPROVED: DATE:

TITLE: BOX 2250L Self Bunded Tank  
DRAWING NO. :  
PURCHASE ORDER NO. :

REV: 01  
SHEET: 1 of 5  
Scale: No scale

A3



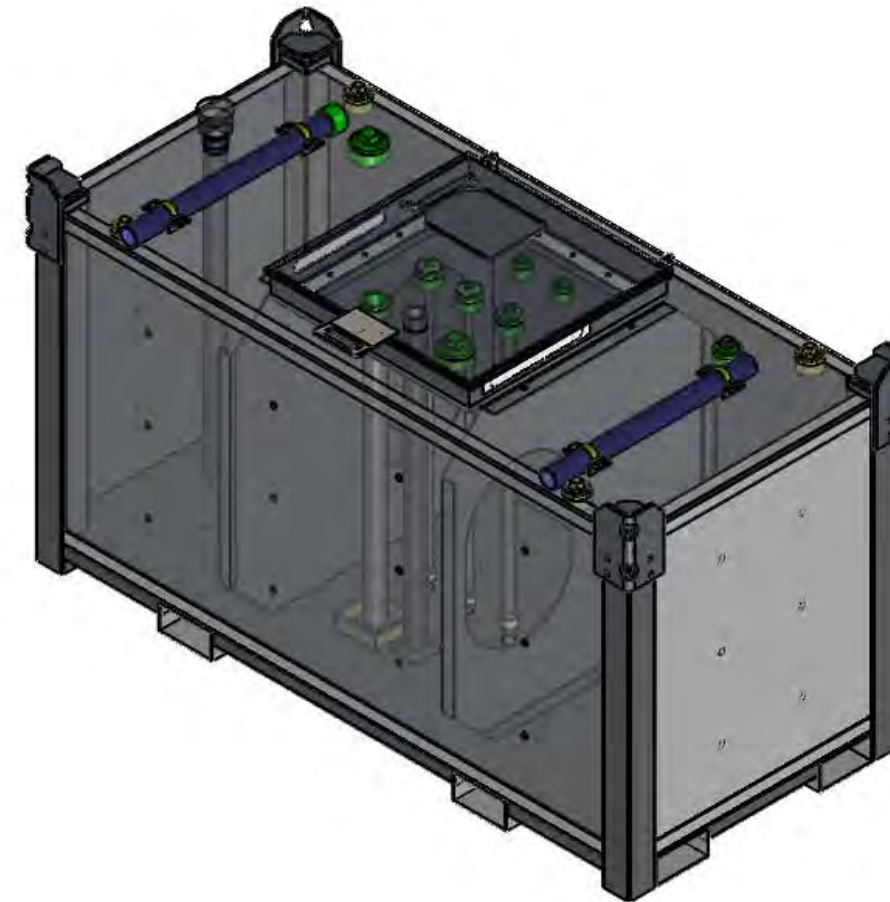
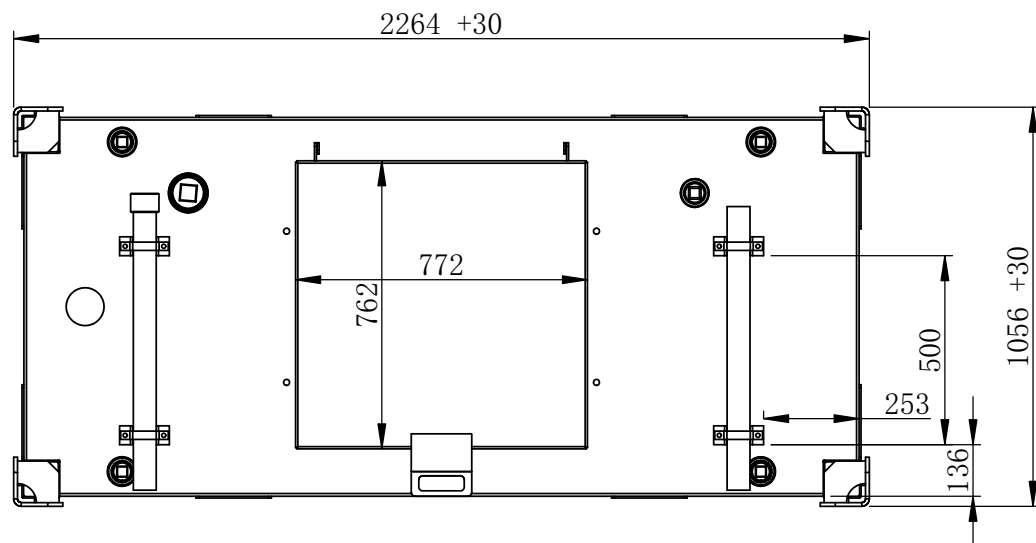
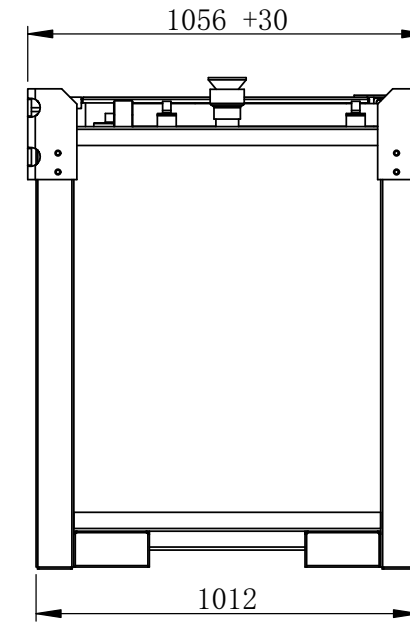
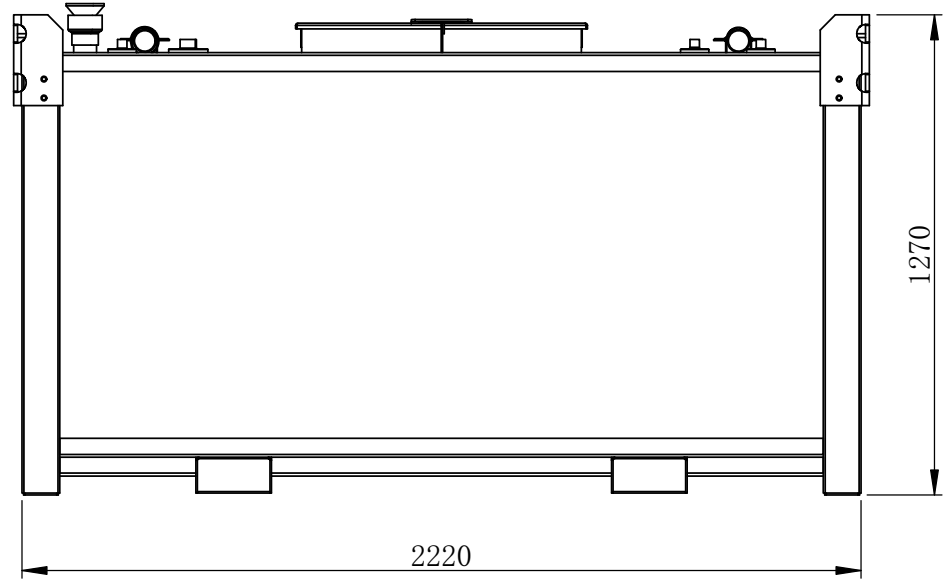

07					
06					
05					
04					
03					
02					
01					
REV:	DATE:	REVISION:	DRAWN:	CHECKED:	APPROVED:



Material:  
Weight: 887.62KG

DRAWN:  
DATE: 2020-06-29  
CHECKED:  
DATE:  
CLIENT:  
DATE:  
APPROVED:  
DATE:

TITLE:  
BOX 2250L Self Bunded Tank  
DRAWING NO. :  
PURCHASE ORDER NO. :

REV: 01  
SHEET: 2 of 5  
Scale: No scale

A3





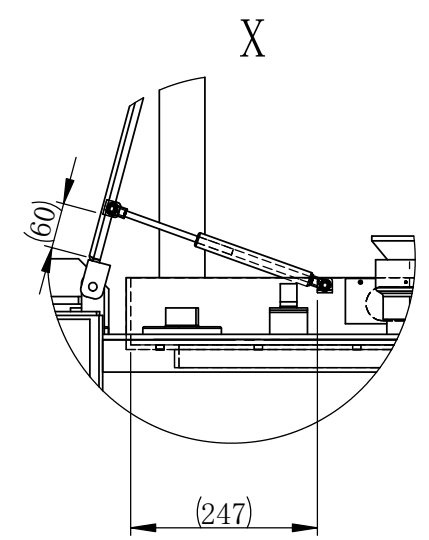
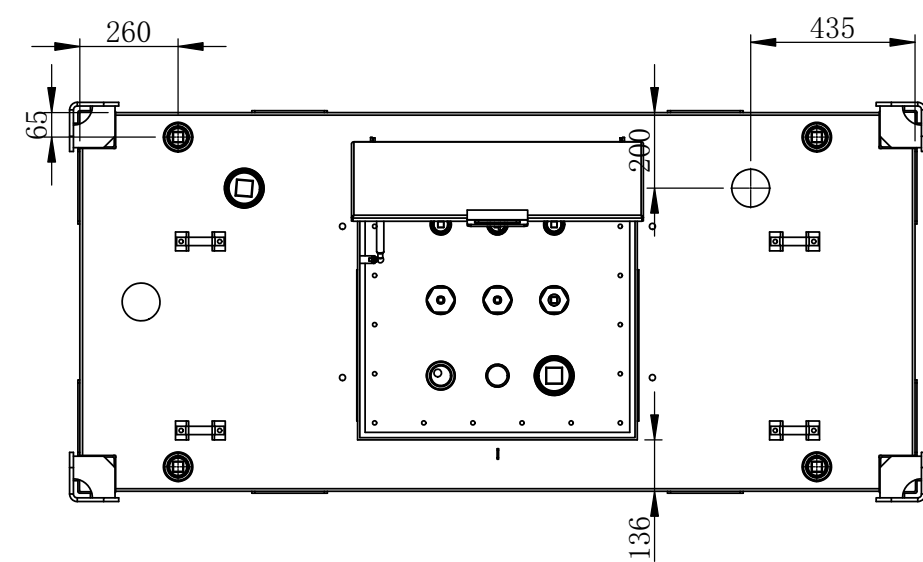
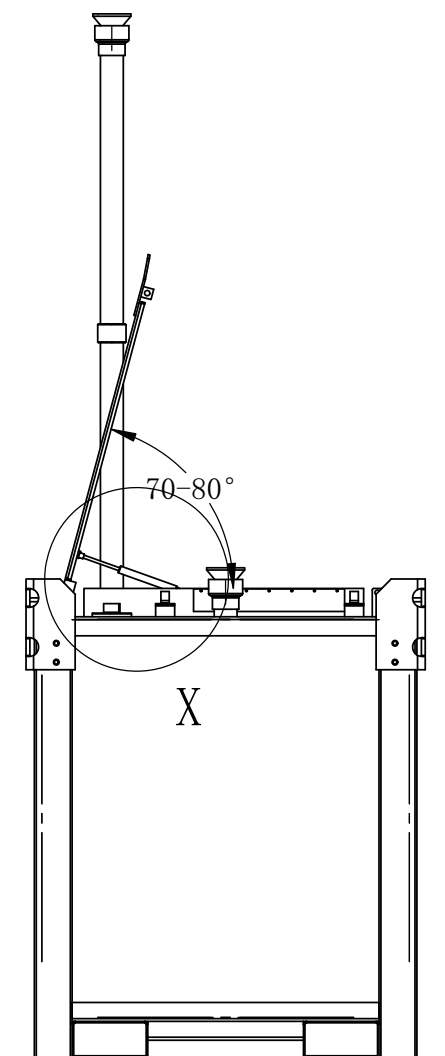
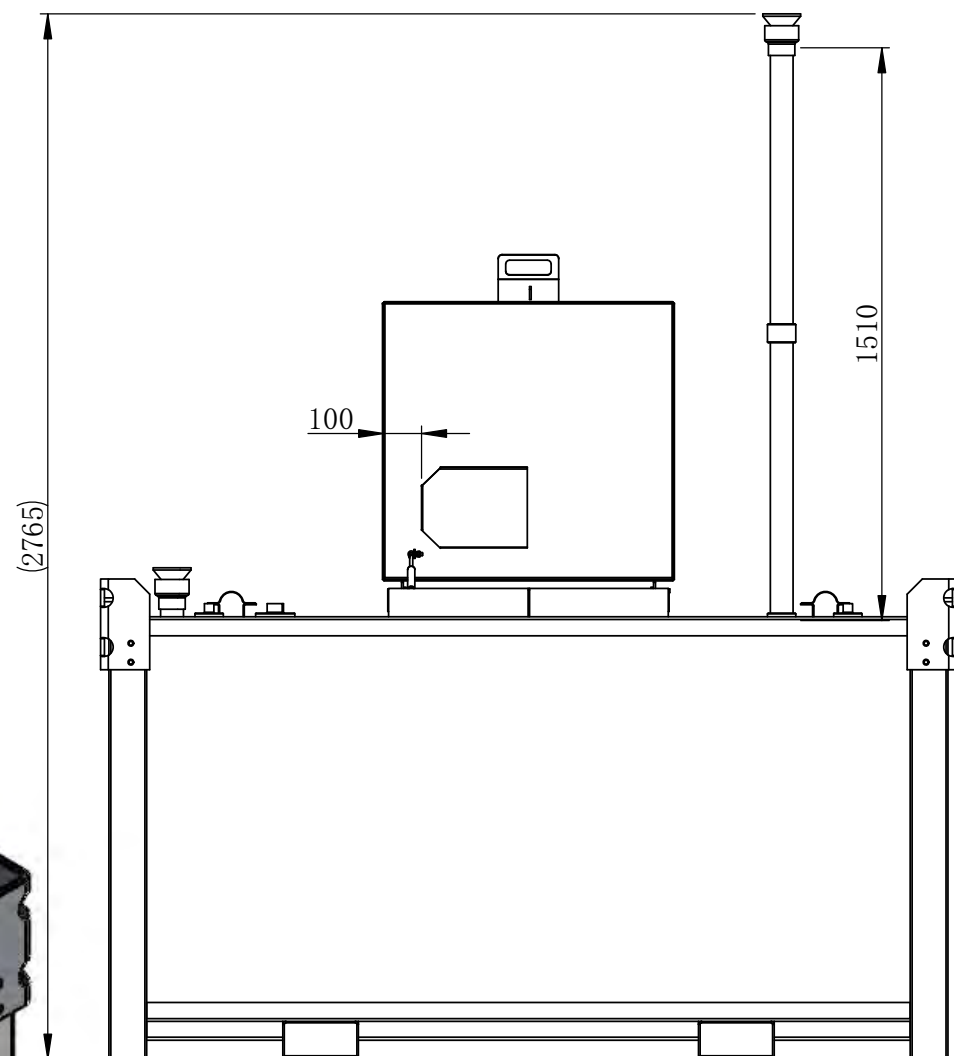
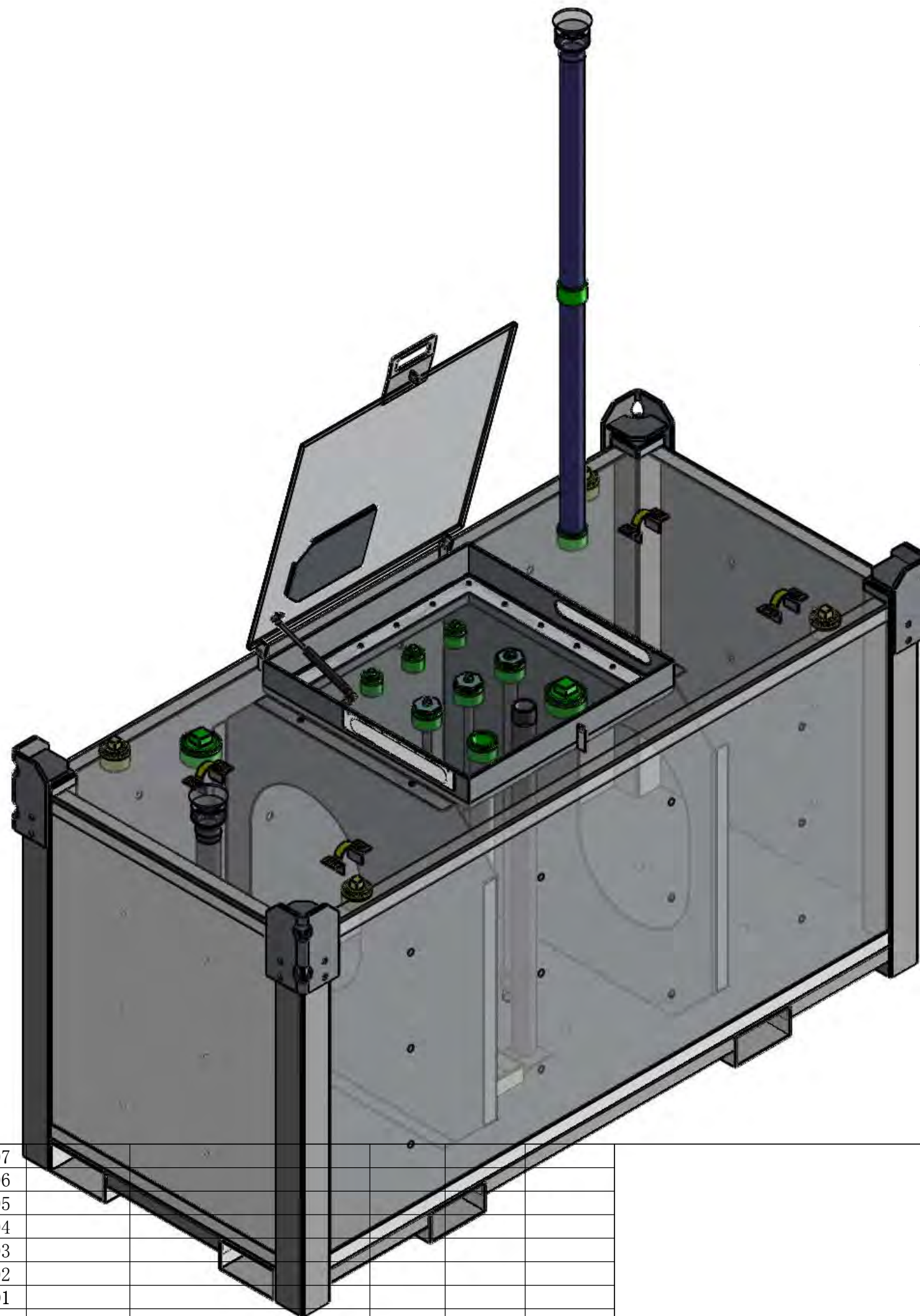

07					
06					
05					
04					
03					
02					
01					
REV:	DATE:	REVISION:	DRAWN:	CHECKED:	APPROVED:



Material:  
Weight: 888.49KG

DRAWN: DATE: 2020-06-29  
 CHECKED: DATE:  
 CLIENT: DATE:  
 APPROVED: DATE:

TITLE:  
BOX 2250L Self Bunded Tank  
 DRAWING NO. :  
 PURCHASE ORDER NO. :  
 REV: 01  
 SHEET: 3 of 5  
 Scale: No scale

A3

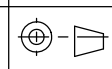

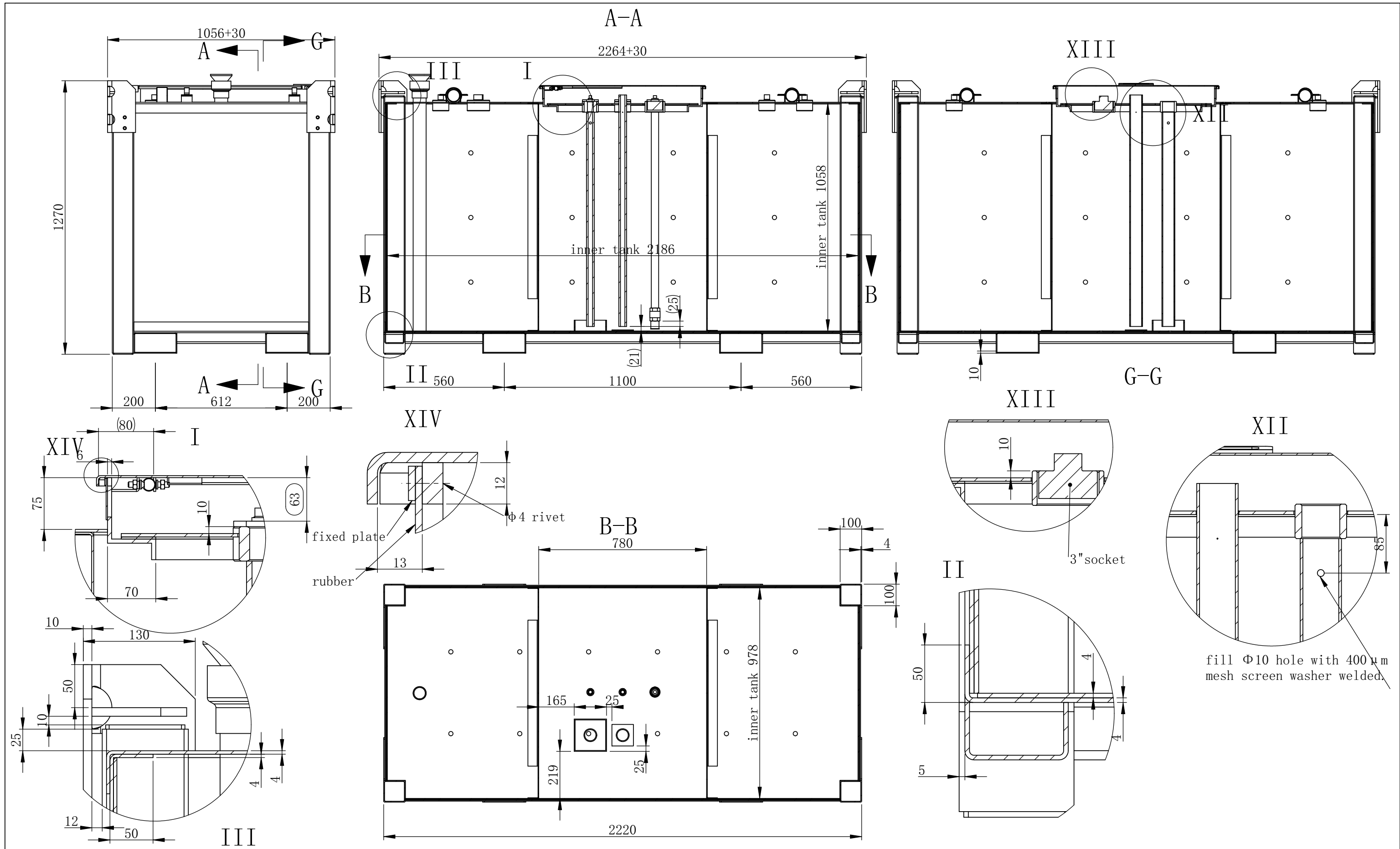

07					
06					
05					
04					
03					
02					
01					
REV:	DATE:	REVISION:	DRAWN:	CHECKED:	APPROVED:



Material:  
Weight: 884.82KG

DRAWN:  
DATE: 2020-07-03  
CHECKED:  
DATE:  
CLIENT:  
DATE:  
APPROVED:  
DATE:

TITLE:  
BOX 2250L Self Bunded Tank  
DRAWING NO. :  
PURCHASE ORDER NO. :

REV: 01  
SHEET: 4 of 5  
Scale: No scale

A3

