

Tank	
TANK CONTENTS	
DESIGNED TO	AS1940 / AS1692
BUILT TO	AS1657 / AS1554.1
PLATE THICKNESS, Material	4/4 mm, Q235B
Pressue Test	35KPA
External size	4867x2294x1270mm
Internal size	4768x2186x1058mm
GROSS VOLUME	11000L
SAFE FILL LEVEL	10000L
N. D. T.	Require By Client
TOTAL MASS	2662. 15KG

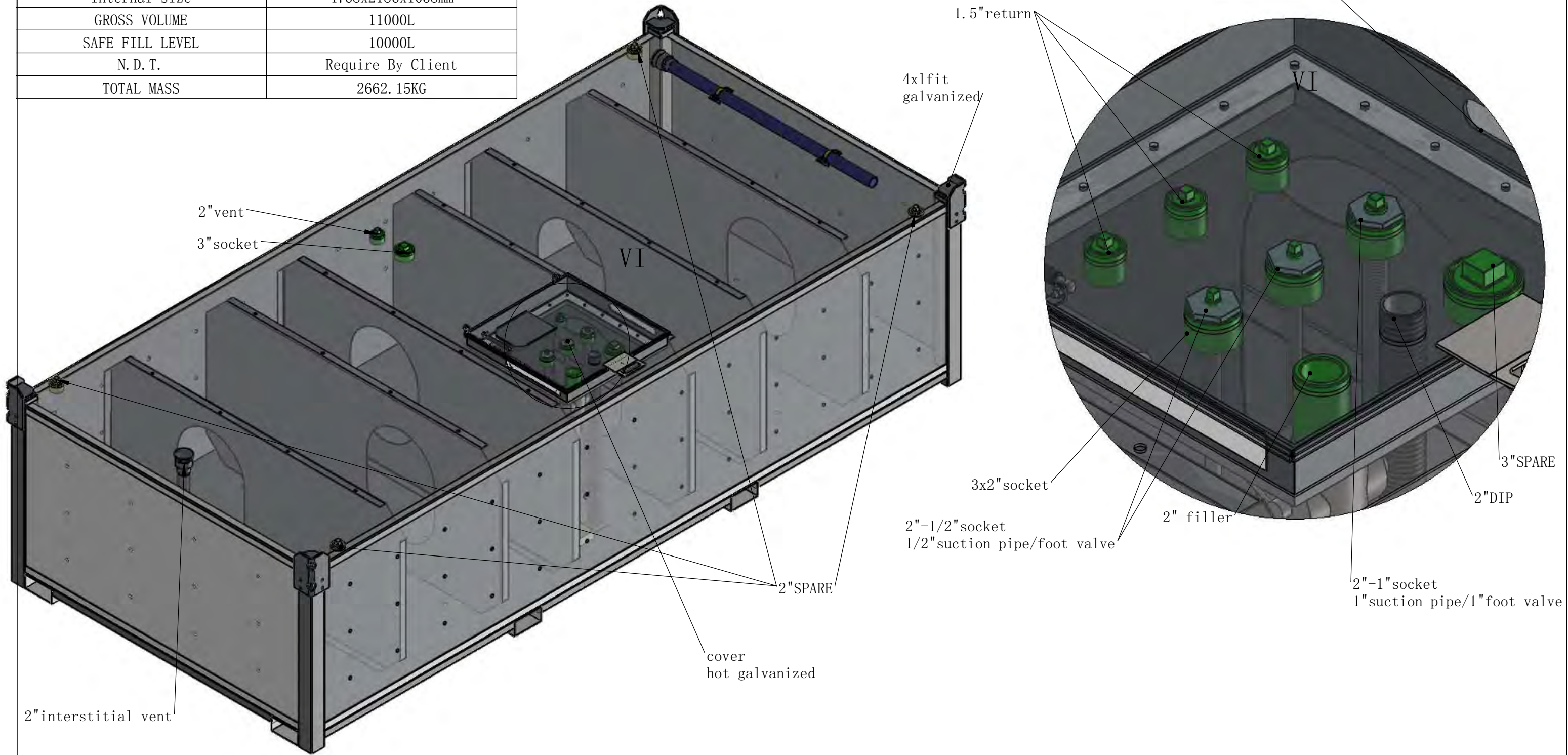

07					
06					
05					
04					
03					
02					
01					
REV:	DATE:	REVISION:	DRAWN:	CHECKED:	APPROVED:



Material:
Weight: 2662. 15KG

DRAWN: DATE: 2020-07-02
 CHECKED: DATE:
 CLIENT: DATE:
 APPROVED: DATE:

TITLE: BOX 11000L Self Bunded Tank
 DRAWING NO. :
 PURCHASE ORDER NO. :

REV: 01
 SHEET: 1 of 4
 Scale: No scale

A3



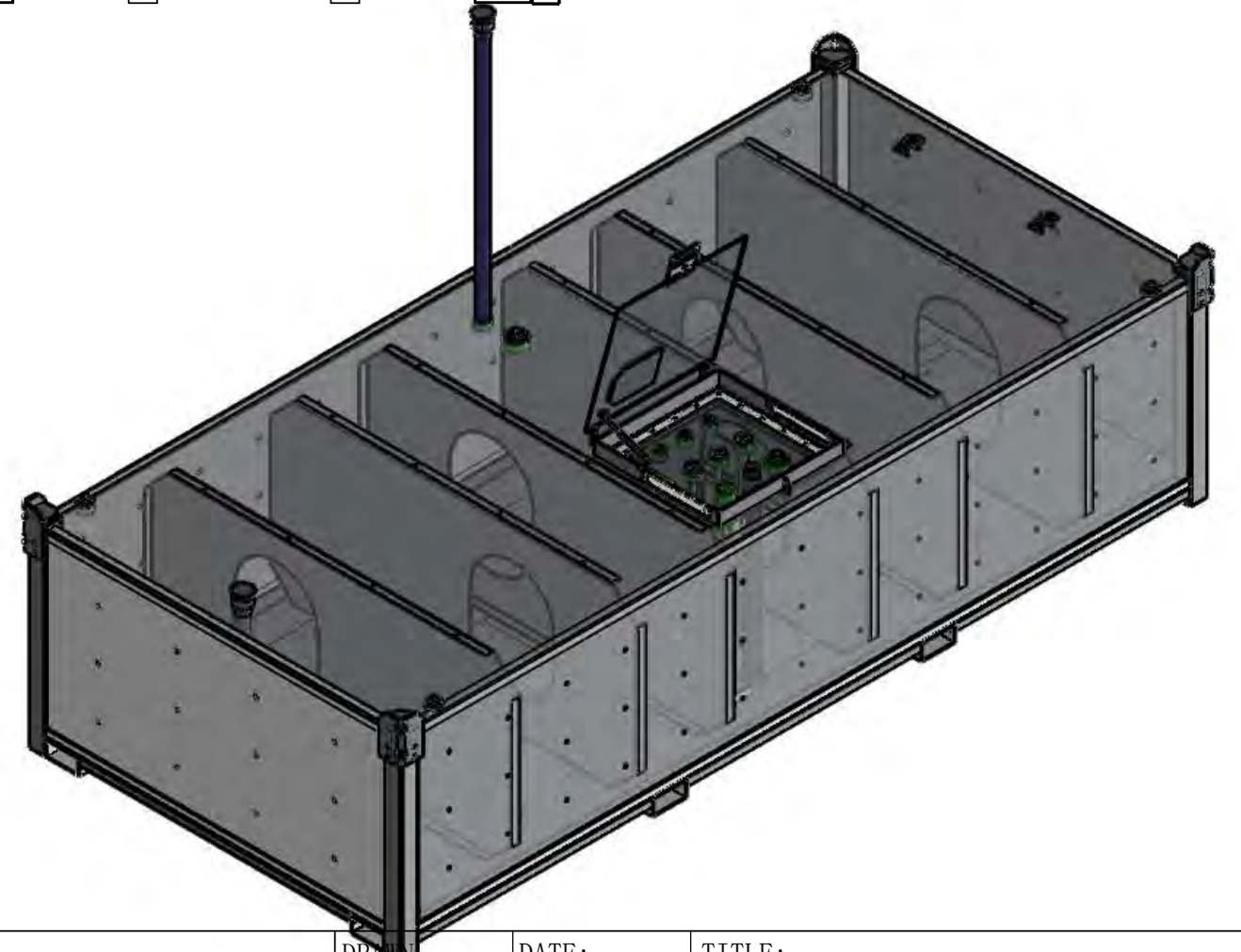
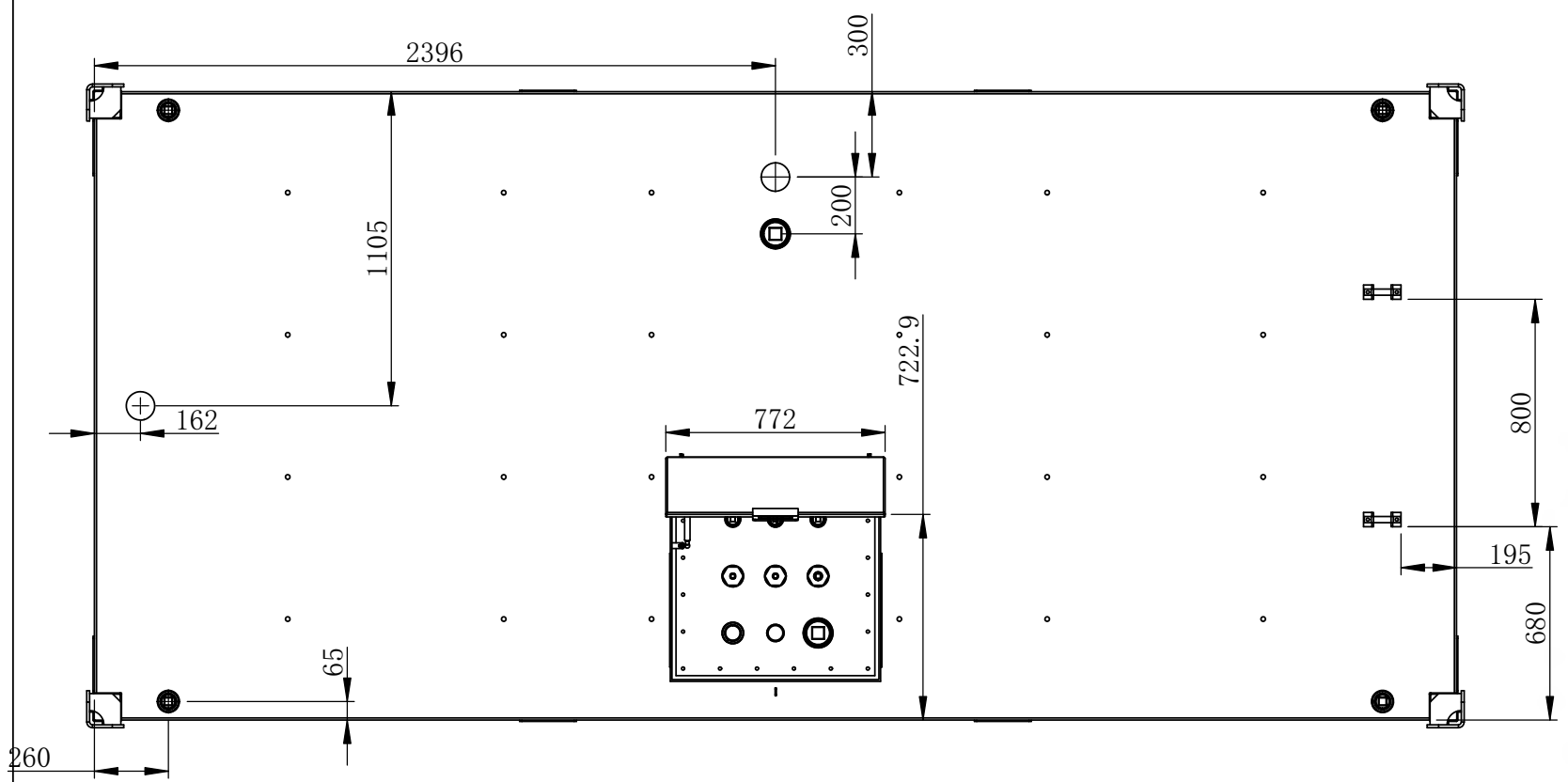
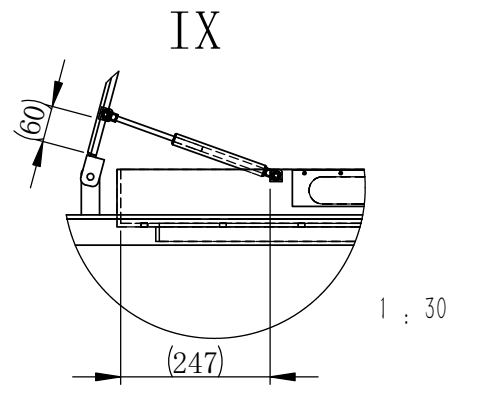
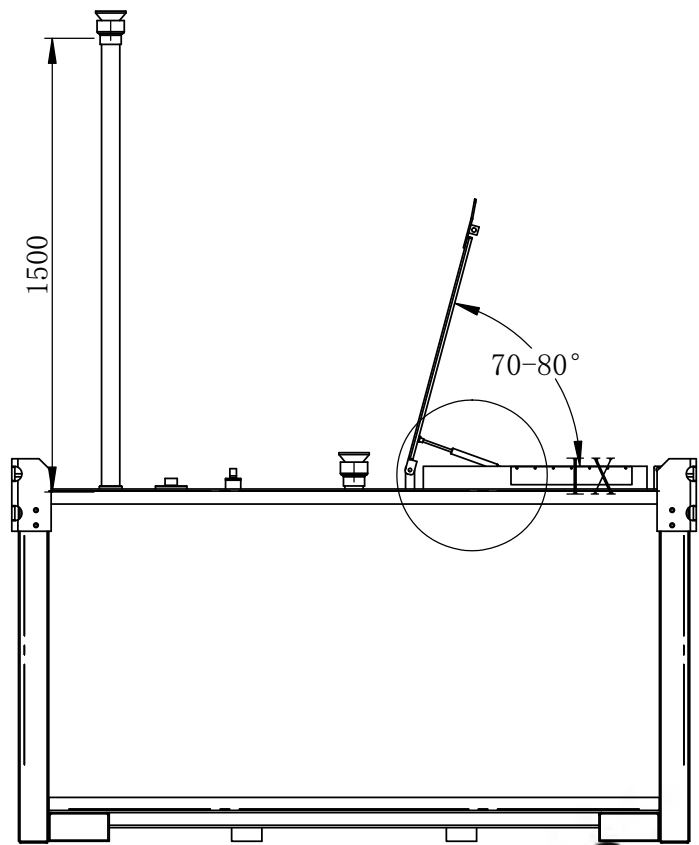
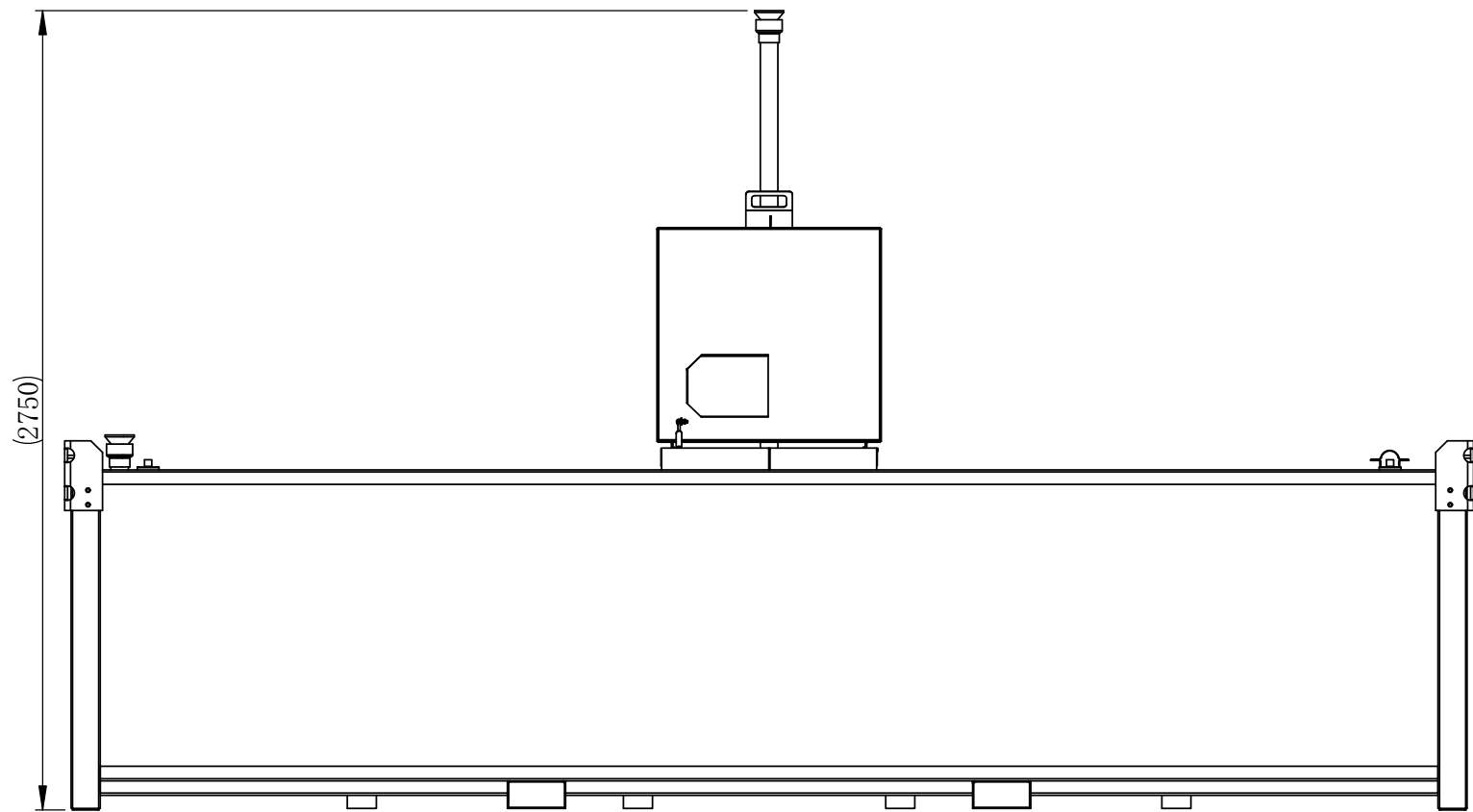

07					
06					
05					
04					
03					
02					
01					
REV:	DATE:	REVISION:	DRAWN:	CHECKED:	APPROVED:



Material:
Weight: 2662.15KG

DRAWN:	DATE: 2020-07-02
CHECKED:	DATE:
CLIENT:	DATE:
APPROVED:	DATE:

TITLE: BOX 11000L Self Bunded Tank	
DRAWING NO. :	REV: 01
	SHEET: 2 of 4
PURCHASE ORDER NO. :	Scale: No scale

A3



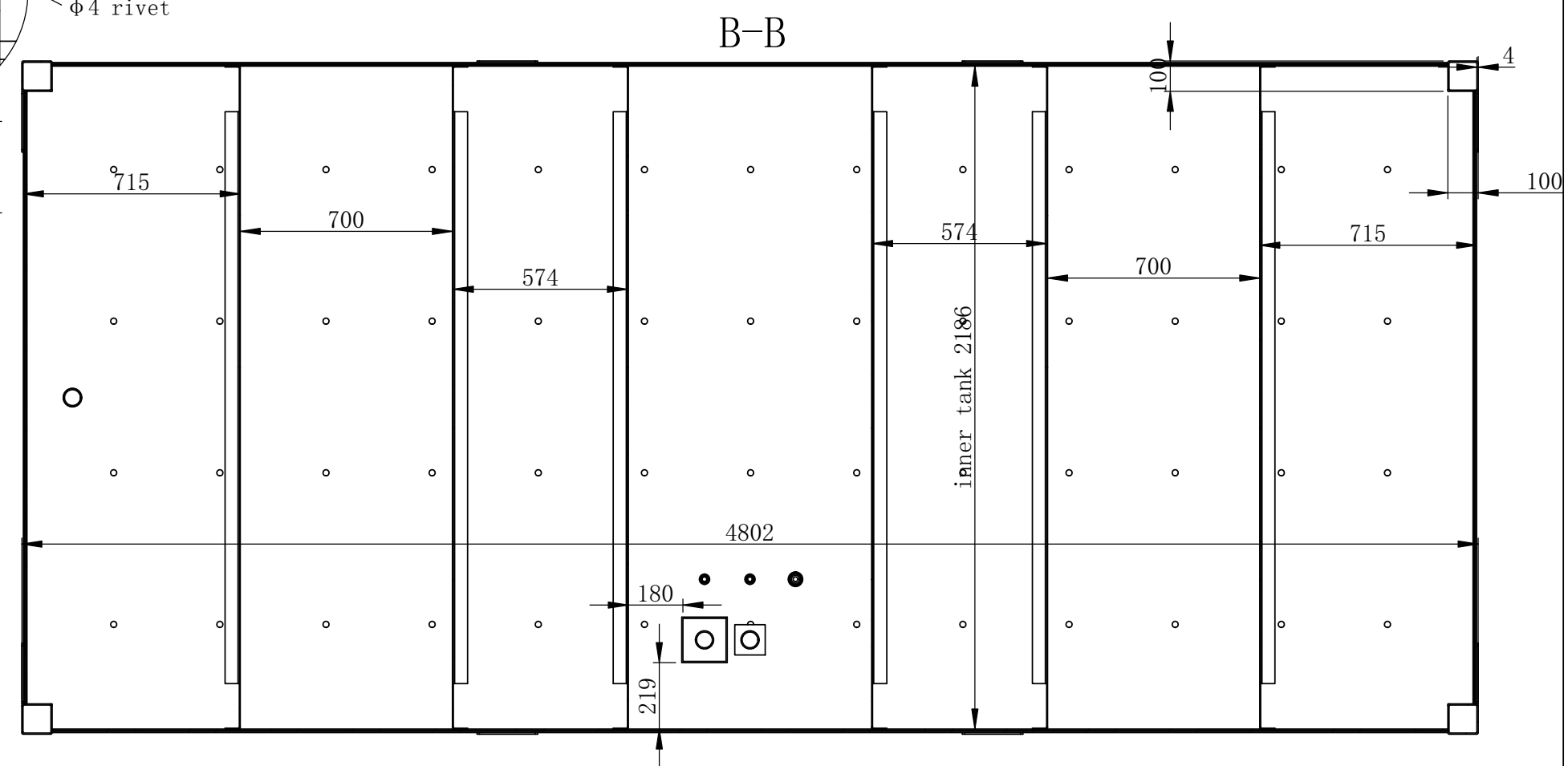
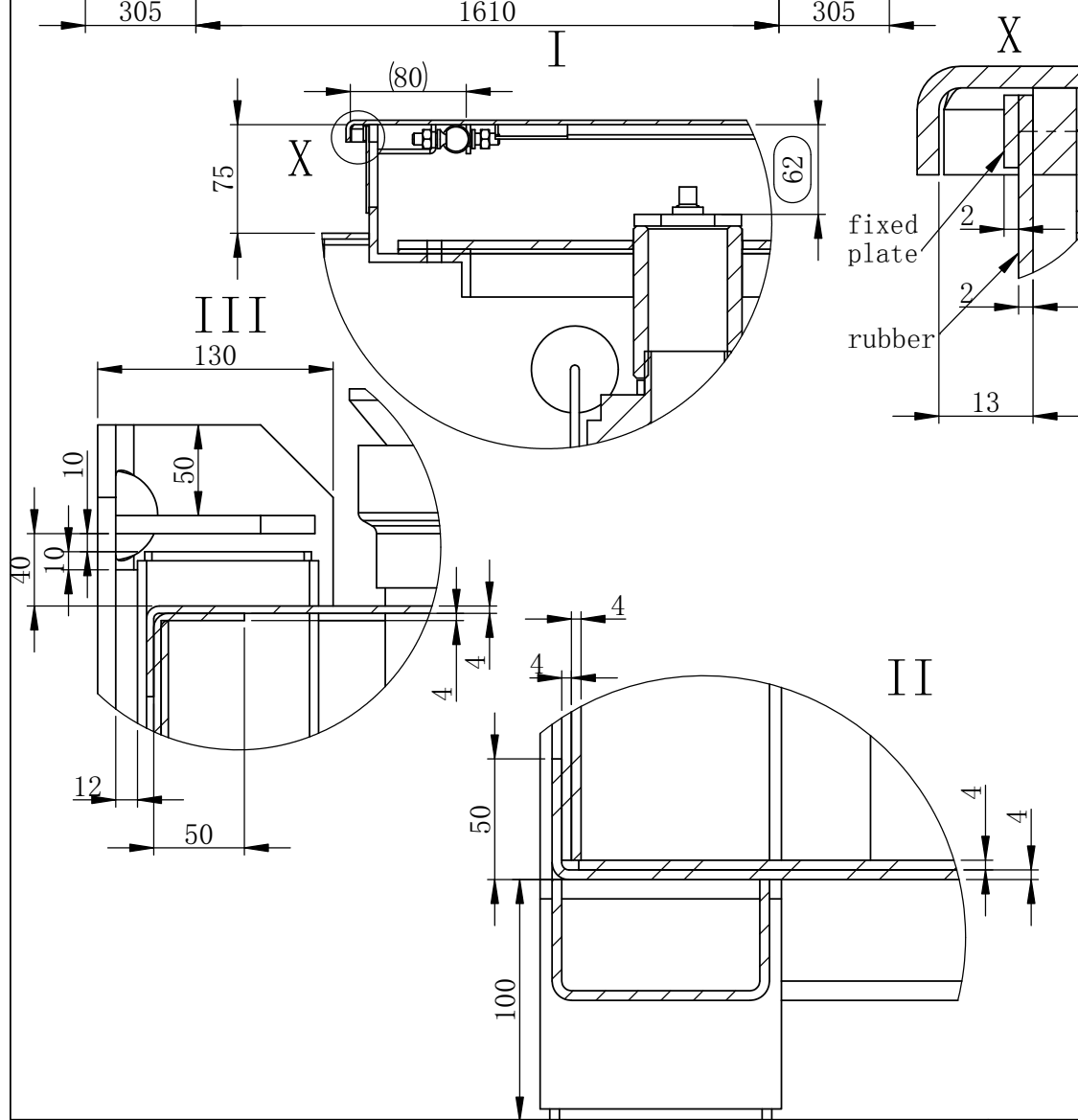
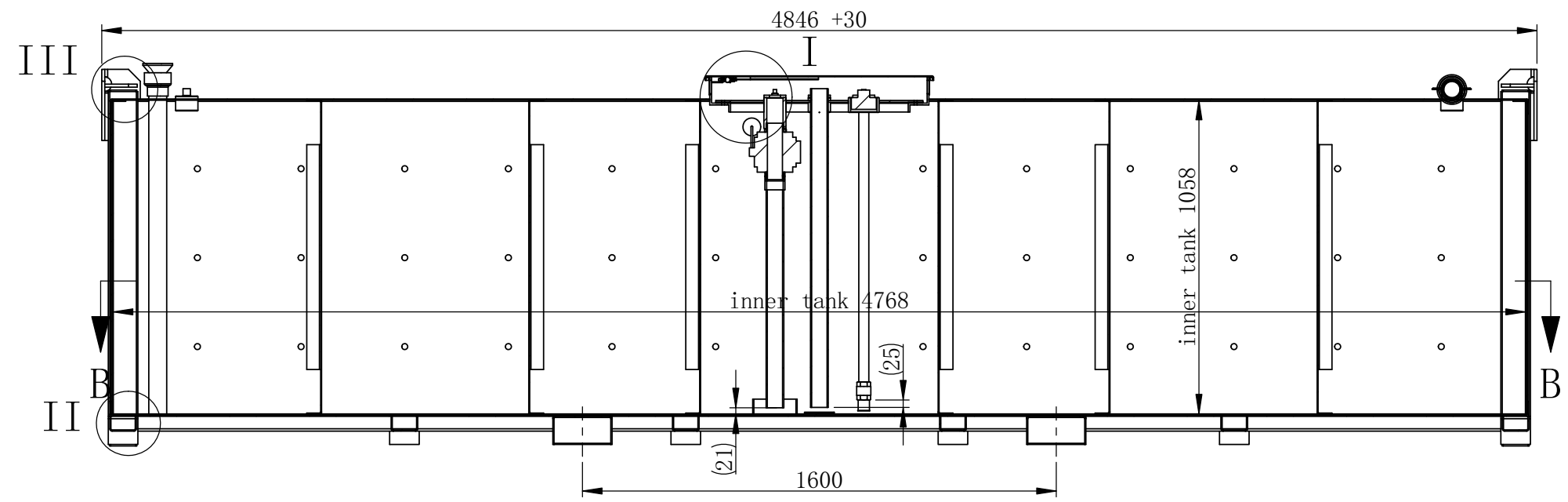
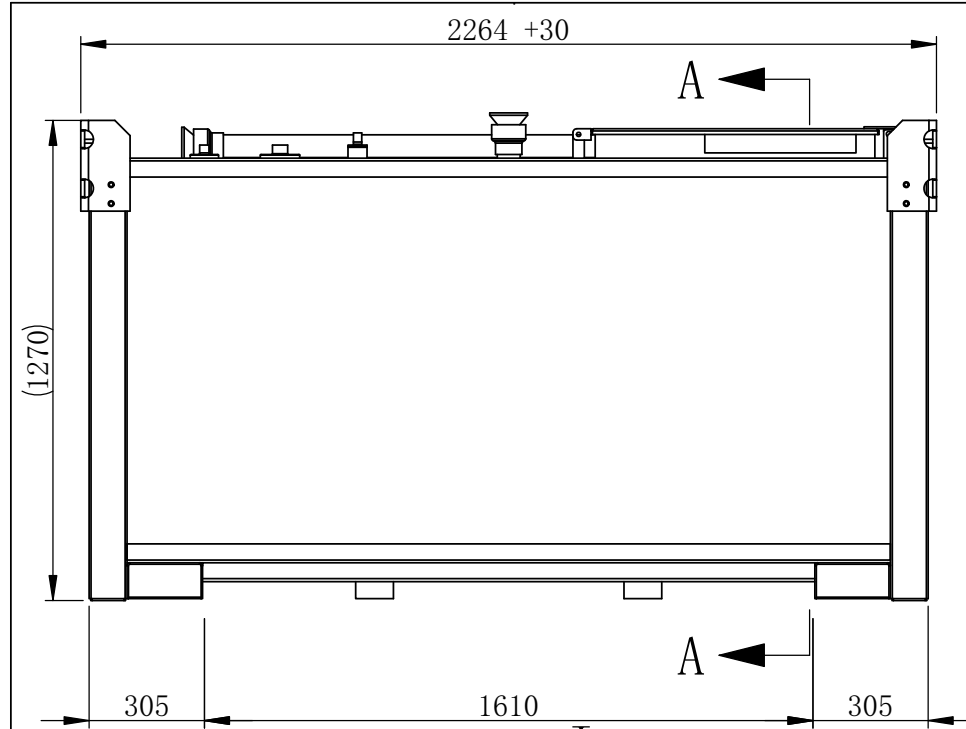

07					
06					
05					
04					
03					
02					
01					
REV:	DATE:	REVISION:	DRAWN:	CHECKED:	APPROVED:



Material:
Weight: 2662.15KG

DRAWN:
CHECKED:
CLIENT:
APPROVED:

DATE:
2020-07-02
DATE:
DATE:
DATE:

TITLE:
BOX 11000L Self Bunded Tank

DRAWING NO. :
PURCHASE ORDER NO. :

REV: 01
SHEET: 3 of 4
Scale: No scale

A3

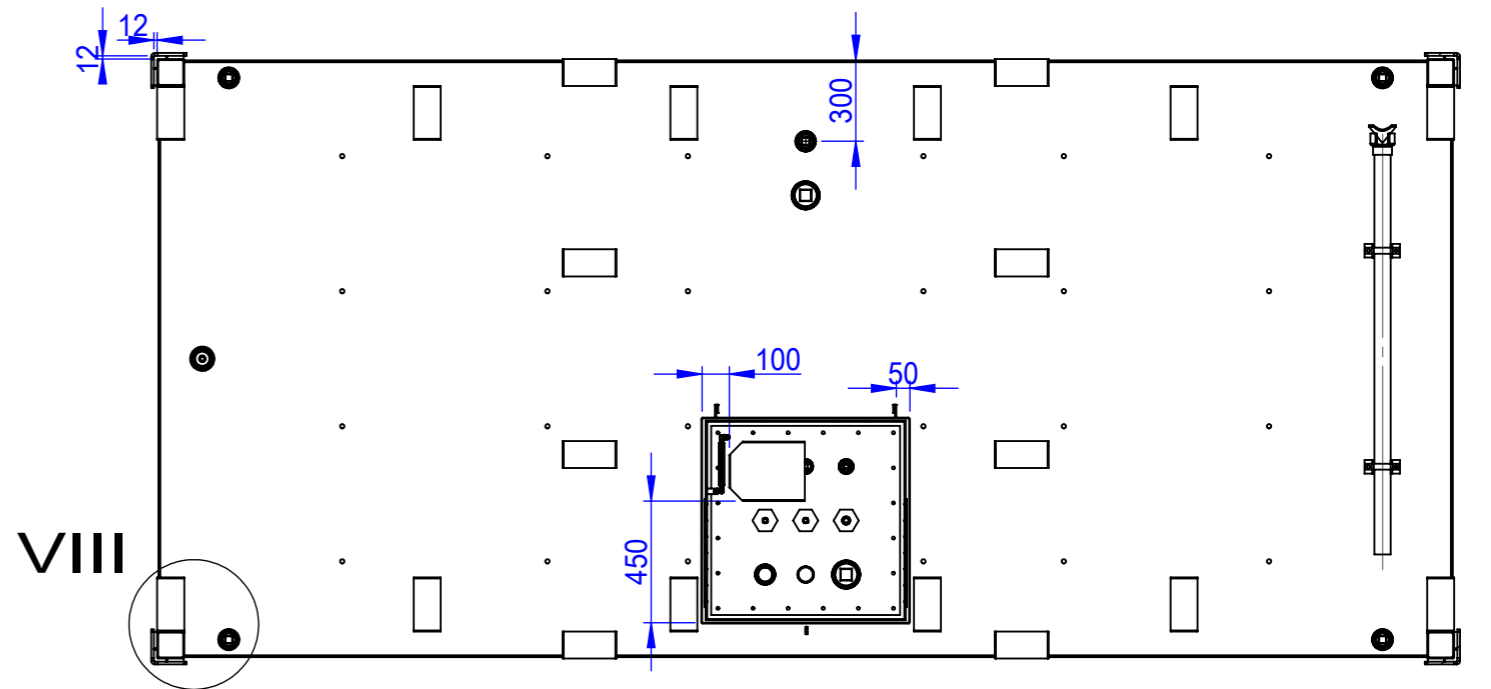
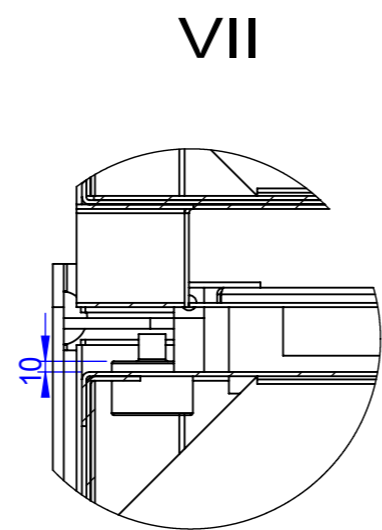
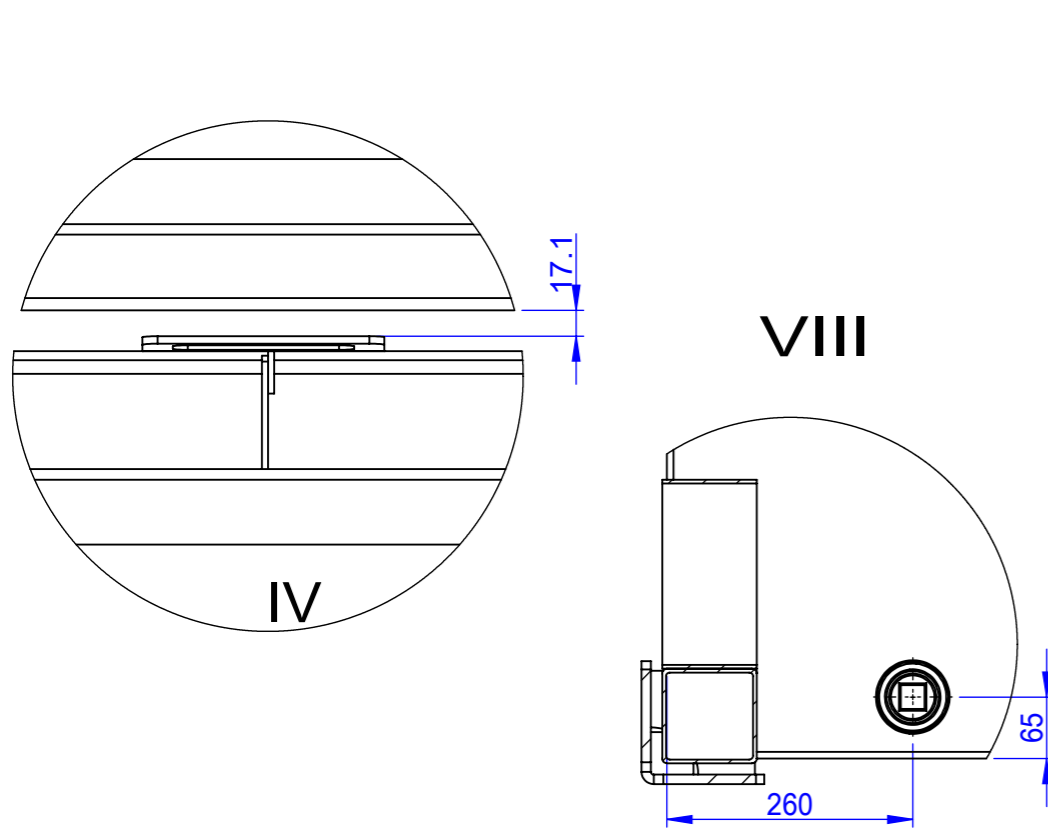
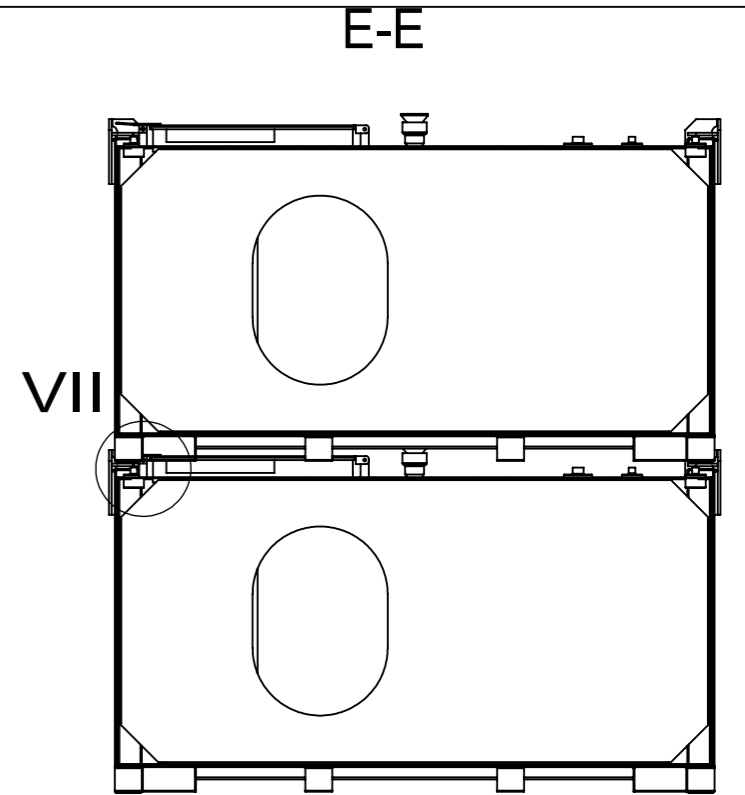
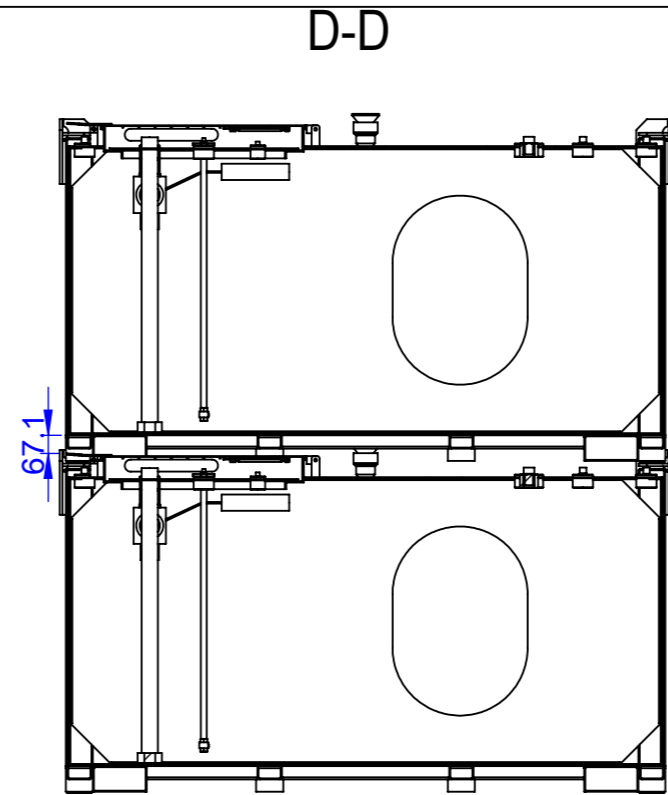
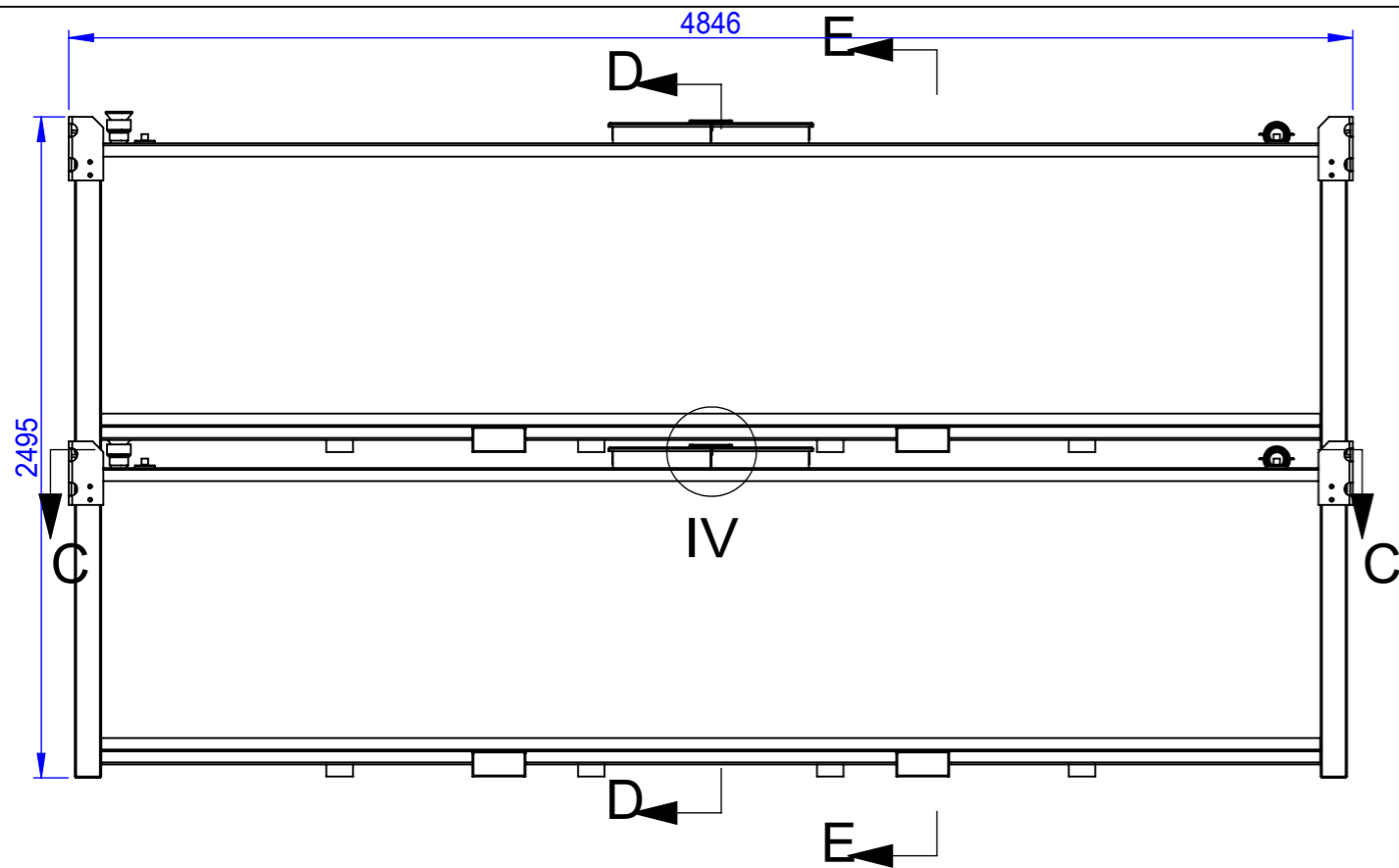

07					
06					
05					
04					
03					
02					
01					
REV:	DATE:	REVISION:	DRAWN:	CHECKED:	APPROVED:



Material:
Weight: 5311.75KG

DRAWN:

CHECKED:

CLIENT:

APPROVED:

DATE:

2019/7/4

DATE:

DATE:

DATE:

TITLE:

BOX 11000L Self Bunded Tank

DRAWING NO. :

PURCHASE
ORDER NO. :

REV:

01

SHEET:

4 of 4

Scale:

No scale

A3

