



DISPENSERS



PUMPS



METERS



NOZZLE



FILTRATION

FLUID
MONITORING

E80 / E120

FUEL
REFUELLING SOLUTIONS

FEATURES

- VERSATILITY
- STURDY STRUCTURE
- LONG LASTING
- REASY TO USE
- THERMAL PROTECTION

The PIUSI E80 and E120 are self-priming rotary electric vane pumps, compact and easy to install, suitable to meet all those use requirements needing a high-performance and long lasting product. Its sturdy structure along with the thermal protection and the top-quality components allow its use at low working temperatures.

PERFORMANCE

UP TO

110 L/MIN

FLOW-RATE

AC**CONTINUOUS DUTY**

POWER

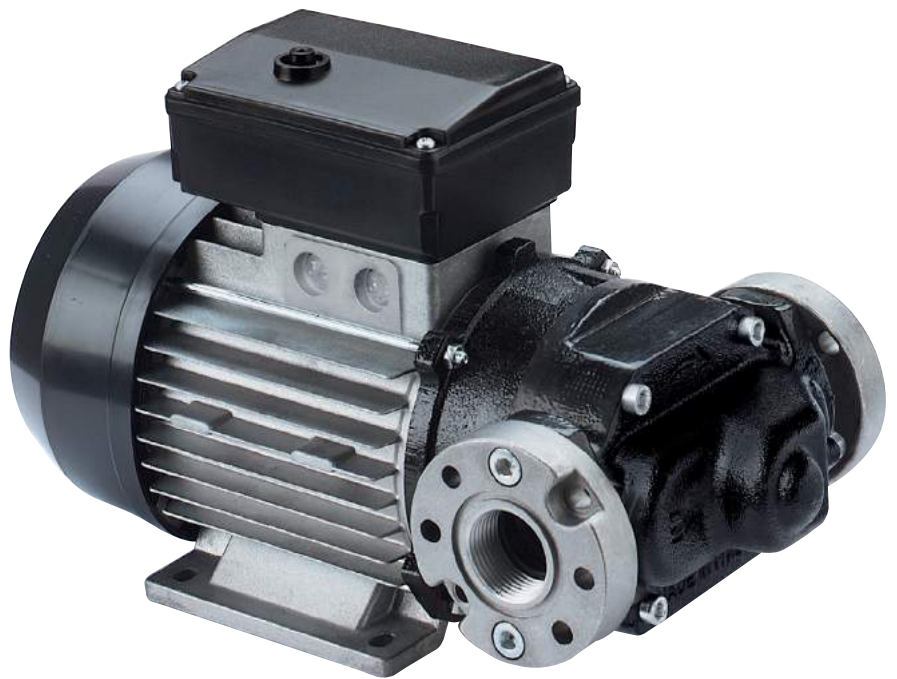

E80/E120



PACKAGING

CODE	WEIGHT		PACKAGING			N. BOXES / EUROPALLET	
	KG	LBS	MM	INCH	PCS/BOX	✕	
E 80							
000305000	13	28,7	355X185X285	-	1	60	72
000307000	13	28,7	355X185X285	-	1	60	72
E 120							
000326000	15,6	34,4	355X185X285	-	1	60	72
000312000	15,6	34,4	355X185X285	-	1	60	72



HOSE REELS



ACCESSORIES



MERCHANDISE

INDEX



AIR



ANTIFREEZE



AdBlue®



BIODIESEL



DIESEL



FOOD



GASOLINE



GREASE



KEROSENE



OIL



WATER



WINDSCREEN

CHART

E80 - E120

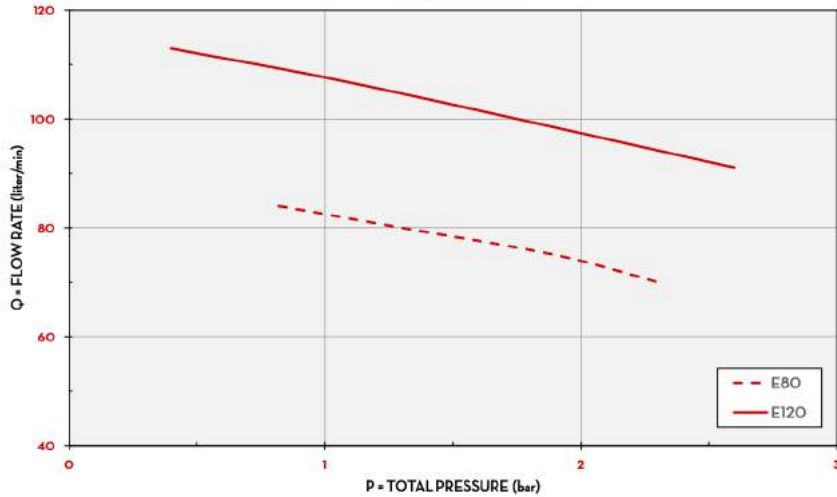

TYPE OF FLUID DIESEL
 TEMPERATURE 15-13 °C

IN THE BOX

- E80/E120 PUMP
- FLANGED CONNECTION
- INSTRUCTION MANUAL

DETAILS



VANE ROTOR



FLANGED CONNECTION

DIMENSIONS

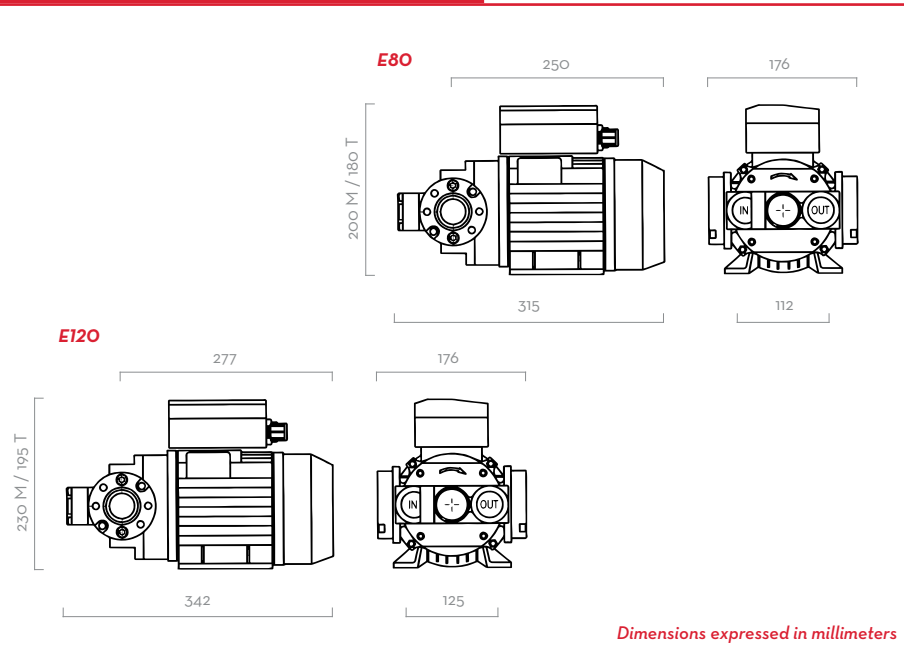

MATERIALS

- BODY: CAST IRON
- ROTOR: SINTERED STEEL
- VANES: ACETAL RESIN
- SEAL: VITON
- SHAFT: STEEL



PUMP

- > MAX 6M (20FT),
- > SUCTION HOSE Ø 1" MIN,
- > MAX SUCTION HEIGHT:
 - 2M (7FT) W/O NON RETURN VALVE
 - 4M (14FT) W NON RETURN VALVE



TANK

TECHNICAL DATA

CODE	DESCRIPTION	FLUIDS TYPE	FLOW-RATE		VOLTAGE				RPM	INLET OUTLET BSP	FLANGE CONNECTION	BYPASS VALVE	INLET FILTER
			L/MIN	GPM	SINGLEPHASE MOTOR V/HZ	THREEPHASE MOTOR V/HZ	POWER WATT	AMP. MAX.					
E 80													
000305000	E 80 M	D	70	18	230/50	-	500	3,5	1400	1"	YES	YES	NO
000307000	E 80 T	D	70	18	-	400/50	550	1,6	1450	1"	YES	YES	NO
E 120													
000326000	E 120 M	D	100	26	230/50	-	750	5,7	1450	1"	YES	YES	NO
000312000	E 120 T	D	100	26	-	400/50	750	2,2	1450	1"	YES	YES	NO

E80 / E120