



PATTERN COLLECTION: *WOMEN*



Walking Bird Cardigan

Designed by Kristin Hansen

SIZES

Small (Medium, Large, 1X, 2X)

Sample shown in Small size

FINISHED MEASUREMENTS

Bust, buttoned: 36½ (40½, 44½, 48½, 52½)"

Length: 26½ (27, 27½, 28, 28¼)"

MATERIALS

Classic Shades (70% acrylic, 30% wool; 100 g/197 yds)

- 723 Stained Glass – 6 (7, 7, 8, 8) balls

Needles: US Size 9 (5.5 mm) and US Size 10 (6 mm) 32" circular needles, set of dpns for sleeves *or size needed to obtain gauge*

US Size 10½ (6.5 mm) straight circular (for 3 needle bind off)

Notions: tapestry needle, seven 5/8" buttons, stitch holders

GAUGE

16 sts x 20 rows = 4" in St st using middle ndl

Save time, check your gauge.

Knit. Relax. Smile. Repeat!

2013 © Universal Yarn, Inc.

All rights reserved.

www.universalyarn.com

This pattern may not be reproduced for business, trade or sale.

STITCH GUIDE

Seed Stitch

(even number of sts)(worked flat)

Row 1 (RS): * K1, p1; rep from * to end of row

Row 2 (WS): * P1, k1; rep from * to end of row.

Rep rows 1-2 for patt.

Seed Stitch

(even number of sts)(worked in the rnd)

Rnd 1: * K1, p1; rep from * to end of rnd

Rnd 2: * P1, k1; rep from * to end of rnd.

Rep rnds 1-2 for patt.

Kfbf: Knit into the front leg, then the back leg, then the front leg again of the next st – 2 sts inc'd.

PEPLUM

With middle ndl, cast on 3 sts.

Increase Section

Row 1 (RS): Wyib, sl 1, yo, kfbf, yo, k1 - 7 sts.

Row 2 (WS): Wyif sl 1, purl to end of row.

Row 3: Wyib sl 1, yo, knit to last st, yo, k1 – 2 sts inc'd.

Rep Rows 2 & 3 above, until Peplum meas 8½ (8½, 8½, 9, 9)" along right hand edge.

Straight Section

Row 1 (RS): Beg at top edge of Peplum, wyib sl 1, ssk, knit to last st, yo, k1.

Row 2 (WS): Wyif, sl 1, purl.

Rep Rows 1 & 2 above until there are 140 (156, 172, 188, 204) slipped sts along top edge of Peplum. Loosely bind off all sts.

CARDIGAN BODY

With smallest ndl, beg at Right Front edge of Peplum, pick and knit 1 st in each slipped st along top edge of Peplum – 140 (156, 172, 188, 204) sts. Work in garter st (knit every row) until Body meas 3". Change to middle

ndl. Work even in Seed Stitch until Body meas 9½" (all sizes), ending with WS row.

Divide for Fronts and Back:

Next row (RS): Work 31 (35, 37, 41, 45) sts in est patt for Right Front, bind off next 8 (8, 12, 12, 12) sts, place Right Front sts on holder, work next 62 (70, 74, 82, 90) sts in est patt for Back, bind off next 8 (8, 12, 12, 12) sts, place Back sts on holder, work in est patt to end of row – 31 (35, 37, 41, 45) sts rem for Left Front.

Left Front

Cont in est patt until Left Front meas 4½ (5, 5, 5½, 5½)" from division of Fronts and Back, ending with RS row.

Shape Left Front Neck

Bind off 4 (4, 5, 5, 5) sts at beg of next WS row. Bind off 2 sts at beg of next 2 WS rows. Bind off 1 st at beg of next 5 (5, 5, 6, 7) WS rows – 18 (22, 23, 26, 29) sts rem.

Cont, if necessary, in est patt until Left Front meas 8½ (9, 9½, 9½, 9¾)" from division of Fronts and Back, ending with WS row. Place shoulder sts on holder.

Right Front

Place Right Front sts on middle ndl. Beg with WS row, cont in est patt until Right Front meas 4½ (5, 5, 5½, 5½)" from division of Fronts and Back, ending with WS row.

Shape Right Front Neck

Bind off 4 (4, 5, 5, 5) sts at beg of next RS row. Bind off 2 sts at beg of next 2 RS rows. Bind off 1 st at beg of next 5 (5, 5, 6, 7) RS rows – 18 (22, 23, 26, 29) sts rem.

Cont, if necessary, in est patt until Left Front meas 8½ (9, 9½, 9½, 9¾)" from division of Fronts and Back, ending with WS row. Place shoulder sts on holder.

Knit. Relax. Smile. Repeat!

2013 © Universal Yarn, Inc.

All rights reserved.

www.universalyarn.com

This pattern may not be reproduced for business, trade or sale.

Back

Place Back sts on middle ndl. Work in est patt until Back meas $8\frac{1}{2}$ (9, $9\frac{1}{2}$, $9\frac{1}{2}$, $9\frac{3}{4}$)" from division of Fronts and Back, ending with WS row.

Next row (RS): Work 18 (22, 34, 26, 29) sts in est patt, bind off center 26 (26, 28, 30, 32) sts, work in patt to end. Place shoulder sts on holders.

Join Shoulder Seams

Place left Back shoulder sts & Left Front shoulder sts onto middle circ ndl. Using largest straight ndl, join Left Shoulder Seam using 3 ndl bind off. Rep for Right Shoulder seam.

Sleeves

Instructions are given assuming magic loop method is used. Dpns may also be used.

With middle ndl, beg at underarm, pick up and knit 4 (4, 6, 6, 6) sts along armhole bind off, 60 (64, 64, 64, 64) sts evenly around armhole, and 4 (4, 6, 6, 6) sts long other side of armhole bind off – 68 (72, 76, 76, 76) sts. Pm and join to work in the rnd. Work 4 rnds even in Seed st.

Shape Sleeves

Dec rnd: K2tog, work in patt to last 2 sts, ssk – 2 sts dec'd. Rep Dec rnd every 4 (4, 4, 4, 4) rnds, 14 (17, 17, 12, 9) more times, then rep Dec rnd every 6 (-, 6, 6, 6) rnds, 1 (-, 1, 5, 7) more time(s) – 34 (36, 38, 40, 42) sts rem. Cont in patt, if necessary until Sleeve meas $14\frac{1}{2}$ (15, $15\frac{1}{2}$, 16, $16\frac{1}{2}$)" from underarm. Change to smallest dpns. Knit 1 rnd, decreasing 3 (3, 5, 5, 5) sts evenly spaced on rnd. Work in garter stitch (purl 1 rnd, knit 1 rnd) for $1\frac{1}{2}$ ". Loosely bind off all stitches.

FINISHING

Block all pieces.

Right Front Band

With smallest ndl and RS facing, beg at lower edge of waist band, pick up and knit 2 sts for every 3 rows along Right Front. Knit 3 rows. Mark 6 buttonholes, evenly spaced along Right Front Band, with first button hole $\frac{1}{4}$ " from top of Band and last buttonhole $\frac{1}{4}$ " from bottom of Band.

Buttonhole row (RS): Knit to first marked buttonhole, bind off 2 sts, rep for each marked buttonhole.

Next row (WS): Knit, casting on 2 sts over each 2-st bind-off gap. Cont in garter stitch until Front Band meas $1\frac{1}{2}$ " from pick-up edge. Loosely bind off all sts.

Left Front Band

With smallest ndl and RS facing, beg at lower edge of Waistband, pick up and knit 2 sts for every 3 rows. Work in garter st until Front Band meas $1\frac{1}{2}$ " from pick up edge. Loosely bind off all sts.

Neckline Band

With smallest ndl and RS facing, beg at Right Neck edge along top of Right Front Band, pick up and knit 1 st for each bound-off Neck st, and 3 sts for every 4 rows around entire Neck edge. Knit 3 rows. Mark Neckline buttonhole to line up with buttonholes on the Right Front Band.

Next row (RS): Knit to buttonhole marker, bind off 2 sts.

Next row (WS): Knit, casting on 2 sts over 2-st bind-off gap. Cont in garter st until Neckline Band meas $1\frac{1}{2}$ " from pick up edge. Loosely bind off all sts.

Sew buttons on Left Front to correspond to buttonholes. Weave in ends.

Knit. Relax. Smile. Repeat!

2013 © Universal Yarn, Inc.

All rights reserved.

www.universalyarn.com

This pattern may not be reproduced for business, trade or sale.

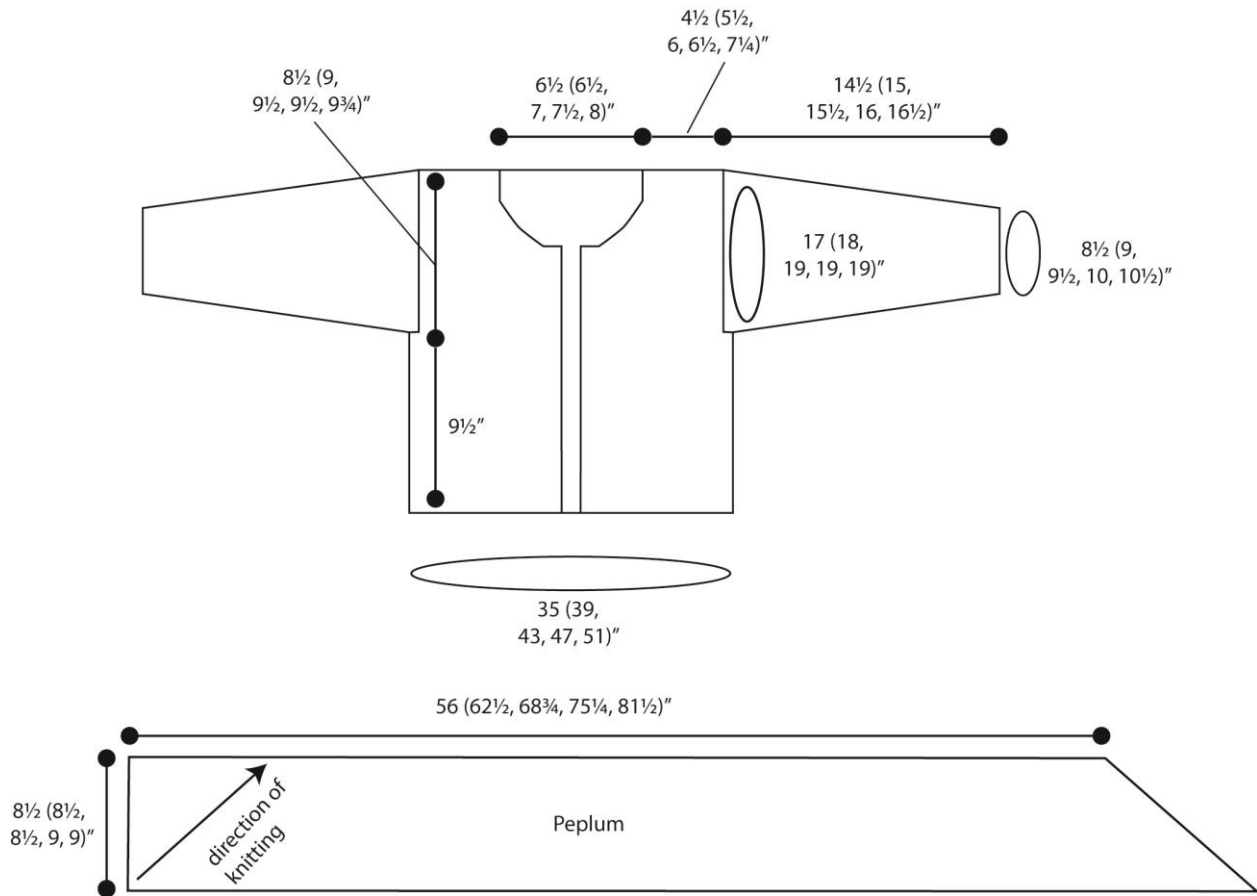

Knit. Relax. Smile. Repeat!

2013 © Universal Yarn, Inc.

All rights reserved.

www.universalyarn.com

This pattern may not be reproduced for business, trade or sale.