



## Pattern Collection: Women



### Swirling River Cardigan

Designed by Universal Yarn Design Team

#### SIZES

Small (Medium, Large, 1X, 2X, 3X)  
Shown in Small size modeled with 3”  
of positive ease.

#### FINISHED MEASUREMENTS

**Bust:** 35½ (38½, 43, 46, 50½, 55)”

#### MATERIALS

**Universal Yarn Uptown DK** (100%  
anti-pilling acrylic; 100g/273 yds)

- 146 Aqua – 5 (6, 7, 8, 9, 9)  
balls

**Needles:** US Size 6 (4 mm) straight *or*  
*size needed to obtain gauge*

US Size 4 (3.5 mm) straight

**Notions:** Tapestry needle, stitch  
markers, removable markers, 6 (7, 7,  
7, 7, 8) ¾” buttons

#### GAUGE

21 sts x 27 rows = 4” in St st using  
larger ndl

30 sts x 28 rows = 4” in K2, P2

Ribbing using smaller ndl, relaxed

**Save time, check your gauge**

*Knit. Relax. Smile. Repeat!*

2015 © Universal Yarn, Inc.

All rights reserved.

[www.universalyarn.com](http://www.universalyarn.com)

This pattern may not be reproduced for business, trade or sale.

## PATTERN NOTES

This cardigan is worked in pieces and seamed.

## STITCH GUIDE

### K2, P2 Ribbing

(multiple of 4 sts + 2)

**Row 1 (RS):** \* K2, p2; rep from \* to last 2 sts, p2.

**Row 2 (WS):** P2, \* k2, p2; rep from \* to end.

Rep Rows 1-2 for patt.

### Little Swirl

(panel of 7 sts)

**Row 1 (RS):** K3, yo, ssk, k2.

**WS Rows 2-10:** Purl.

**Row 3:** K1, k2tog, yo, k1, yo, ssk, k1.

**Row 5:** K2tog, yo, k3, yo, ssk.

**Row 7:** K1, yo, ssk, k2, yo, ssk.

**Row 9:** K2, yo, sl 1-k2-*psso*, yo, k2.

Rep Rows 1-10 for patt.

### Big Swirl

(panel of 15 sts)

**Row 1 (RS):** K5, yo, ssk, k2, yo, ssk, k4.

**WS Rows 2-16:** Purl.

**Row 3:** K3, k2tog, yo, k1, yo, ssk, k2, yo, ssk, k3.

**Row 5:** K2, k2tog, yo, k3, [yo, ssk, k2] 2 times.

**Row 7:** K1, k2tog, yo, k2, k2tog, yo, k1, yo, ssk, k2, yo, ssk, k1.

**Row 9:** K2tog, yo, k2, k2tog, yo, k3, yo, ssk, k2, yo, ssk.

**Row 11:** [K2, yo, ssk] 2 times, k1, k2tog, yo, k2, k2tog, yo.

**Row 13:** K3, yo, ssk, k2, yo, sl 1-k2tog-*psso*, yo, k2, k2tog, yo, k1.

**Row 15:** K4, yo, ssk, k2, yo, ssk, k1, k2tog, yo, k2.

Rep Rows 1-16 for patt.

## LEFT FRONT

With smaller ndl, cast on 54 (58, 66, 70, 78, 86) sts.

### Hem

Work in K2, P2 Ribbing patt for 2", ending with WS row.

**Dec row (RS):** Work in est'd rib, working p2tog in purl columns to dec 11 (11, 13, 13, 15, 17) sts evenly across row – 43 (47, 53, 57, 63, 69) sts rem. Switch to larger ndl, purl a WS row.

## Establish Pattern

**Row 1 (RS):** K4 (5, 7, 8, 10, 12), pm, work Row 1 of Big Swirl patt over 15 sts, pm, k4 (5, 7, 8, 10, 12), pm, work Row 1 of Little Swirl patt over 7 sts, pm, k3 (4, 5, 6, 7, 8), pm, work Row 1 of Little Swirl patt over 7 sts, pm, k3 (4, 5, 6, 7, 8).

**Row 2 (WS):** [Purl to m, work Row 2 of Little Swirl patt to m] 2 times, purl to m, work Row 2 of Big Swirl patt to m, purl to end.

Cont in patt as est'd until piece meas 14½ (14½, 14½, 15, 15, 15)". Place removable marker at right hand side of piece to indicate beg of armhole. Cont in patt until piece meas 4½ (5, 5½, 6, 6¼, 6½)", ending with RS row.

### Shape Neck

Bind off 6 (7, 7, 8, 8, 9) sts at beg of next WS row – 37 (40, 46, 49, 55, 60) sts rem.

*Note: Maintain sts in patt as much as possible during Neck shaping.*

**Dec row (RS):** Work in patt to last 3 sts, ssk, k1 – 1 st dec'd.

**Dec row (WS):** P1, ssp, work in patt to end – 1 st dec'd.

Cont to work a Dec row every row, 2 more times, then work a Dec row every RS row, 5 times – 28 (31, 37, 40, 46, 51) sts rem. Work even until piece meas 7½ (8, 8½, 9, 9¼, 9½)" from marker, ending with WS row. Bind off all sts.

## RIGHT FRONT

With smaller ndl, cast on 54 (58, 66, 70, 78, 86) sts.

### Hem

Work in K2, P2 Ribbing patt for 2", ending with WS row.

**Dec row (RS):** Work in est'd rib, working p2tog in purl columns to dec 11 (11, 13, 13, 15, 17) sts evenly across row – 43 (47, 53, 57, 63, 69) sts rem. Switch to larger ndl, purl a WS row.

## Establish Pattern

**Row 1 (RS):** [K3 (4, 5, 6, 7, 8) pm, work Row 1 of Little Swirl patt over 7 sts, pm] 2 times, k4 (5, 7, 8, 10, 12), pm, work Row 1 of Big Swirl patt over 15 sts, pm, k4 (5, 7, 8, 10, 12).

**Row 2 (WS):** Purl to m, work Row 2 of Big Swirl patt to m, [purl to m, work Row 2 of Little Swirl patt to m] 2 times, purl to end.

Cont in patt as est'd until piece meas 14½ (14½, 14½, 15, 15, 15)". Place removable marker at left hand side

*Knit. Relax. Smile. Repeat!*

2015 © Universal Yarn, Inc.

All rights reserved.

[www.universalyarn.com](http://www.universalyarn.com)

This pattern may not be reproduced for business, trade or sale.

of piece to indicate beg of armhole. Cont in patt until piece meas 4½ (5, 5½, 6, 6¼, 6½)”, ending with WS row.

### Shape Neck

Bind off 6 (7, 7, 8, 8, 9) sts at beg of next RS row – 37 (40, 46, 49, 55, 60) sts rem. Work a WS row even

*Note: Maintain sts in patt as much as possible during Neck shaping.*

**Dec row (RS):** K1, k2tog, work in patt to end – 1 st dec’d.

**Dec row (WS):** Work in patt to last 3 sts, p2tog, p1 – 1 st dec’d.

Cont to work a Dec row every row, 2 more times, then work a Dec row every RS row, 5 times – 28 (31, 37, 40, 46, 51) sts rem. Work even until piece meas 7½ (8, 8½, 9, 9¼, 9½)” from marker, ending with WS row. Bind off all sts.

### BACK

With smaller ndl, cast on 118 (126, 142, 154, 166, 182) sts.

### Hem

Work in K2, P2 Ribbing patt for 2”, ending with WS row.

**Dec row (RS):** Work in est’d rib, working p2tog in purl columns to dec 25 (25, 29, 33, 33, 37) sts evenly across row – 93 (101, 113, 121, 133, 145) sts rem. Switch to larger ndl. Purl a WS row.

### Establish Pattern

**Row 1 (RS):** K4 (5, 7, 8, 10, 12), pm, work Row 1 of Big Swirl patt over 15 sts, pm, k4 (5, 7, 8, 10, 12), pm, [work Row 1 of Little Swirl patt over 7 sts, pm, k3 (4, 5, 6, 7, 8), pm] 4 times, work Row 1 of Little Swirl patt over 7 sts, pm, k4 (5, 7, 8, 10, 12), pm, work Row 1 of Big Swirl patt over 15 sts, pm, k4 (5, 7, 8, 10, 12).

**Row 2 (WS):** Purl to m, work Row 2 of Big Swirl patt to m, [purl to m, work Row 2 of Little Swirl patt to m] 5 times, purl to m, work Row 2 of Big Swirl patt to m, purl to end.

Cont in patt as est’d until piece meas 14½ (14½, 14½, 15, 15, 15)”. Place removable markers each side of piece to indicate beg of armholes. Cont in patt until piece meas 7½ (8, 8½, 9, 9¼, 9½)” from markers, ending with WS row. Bind off all sts.

### SLEEVES

With smaller ndl, cast on 54 (58, 58, 62, 62, 66) sts.

### Cuff

Work in K2, P2 Ribbing patt for 2”, ending with WS row.

**Dec row (RS):** Work in est’d rib, working p2tog in purl columns to dec 9 (11, 11, 13, 13, 15) sts evenly across row – 45 (47, 47, 49, 49, 51) sts rem. Switch to larger ndl, Purl a WS row.

### Establish Pattern

**Row 1 (RS):** K4 (5, 5, 6, 6, 7), pm, [work Row 1 of Little Swirl over 7 sts, pm, k3, pm] 3 times, work Row 1 of Little Swirl over 7 sts, pm, k4 (5, 5, 6, 6, 7).

**Row 2 (WS):** [Purl to m, work Row 2 of Little Swirl to m] 4 times, purl to end.

Cont in patt as est’d for 2 more rows.

**Inc row (RS):** K1, m1, work in patt to last st, m1, k1 – 2 sts inc’d.

*Note: maintain inc’d sts in St st.*

Rep Inc row every 4 rows, - (6, 12, 18, 21, 24) more times, then rep Inc row every 6 rows, 16 (12, 8, 4, 2, -) times – 79 (85, 89, 95, 97, 101) sts. Work even in patt until Sleeve meas 18” from cast-on edge, ending with WS row. Bind off all sts.

### FINISHING

Block pieces to finished measurements.

### Buttonband

With smaller ndl and RS facing, pick up and knit 142 (146, 150, 158, 158, 162) sts evenly along Left Front. Work in K2, P2 Ribbing patt for 12 rows. Bind off all sts in patt.

### Buttonhole Band

With smaller ndl and RS facing, pick up and knit 142 (146, 150, 158, 158, 162) sts evenly along Right Front. Work in K2, P2 Ribbing patt for 7 rows. Place 5 (6, 6, 6, 6, 7) markers for buttonholes along purl columns (on the RS of the work) with the first marker in the second purl column from the bottom of the piece, the last marker in the 5<sup>th</sup> purl column from the top of the neck edge, and the remaining markers evenly spaced in between.

**Buttonhole Row (RS):** K2, p2, k1, \* ^k2tog tbl, [yo] 2 times, k2tog^, work in Ribbing to next marker; rep from \* to end, repeating the instructions from between the ^ symbols for each buttonhole over the 2 purl column stitches and the knit st on either side.

*Knit. Relax. Smile. Repeat!*

2015 © Universal Yarn, Inc.

All rights reserved.

www.universalyarn.com

This pattern may not be reproduced for business, trade or sale.

**Next row (WS):** Work in established rib to end, working [k1, k1 tbl] into each buttonhole. Work 3 more rows in patt. Bind off all sts in patt. Sew buttons to Buttonband beneath buttonholes. Sew shoulder seams. Center bind-off edge of sleeve to shoulder seams. Sew in place. Sew sleeve and side seams.

### Collar

With smaller ndl and RS facing, pick up and knit 142 (146, 146, 150, 150, 154) sts evenly along Neck edge, including side of Buttonband and Buttonhole Band. Work in K2, P2 Ribbing patt for 5 rows.

**Buttonhole Row:** K2, p2, k1, k2tog tbl, [yo] 2 times, k2tog, work in Ribbing to end.

**Next row (WS):** Work in established rib to end, working [k1, k1 tbl] into buttonhole. Work 3 more rows in patt. Bind off all sts in patt. Weave in ends. Block edgings.

### Abbreviations

<b>approx</b>	approximately
<b>circ</b>	circular
<b>cont</b>	continue
<b>dec('d)</b>	decrease(d)
<b>est'd</b>	established
<b>inc('d)</b>	increase(d)
<b>k</b>	knit
<b>k2tog</b>	knit 2 stitches together (1 st dec'd)
<b>m</b>	marker
<b>m1</b>	insert left needle from front to back under horizontal strand of yarn lying between st just worked and next st, knit or purl this st through the back loop (1 st inc'd)
<b>meas</b>	measures
<b>ndl</b>	needle
<b>patt</b>	pattern
<b>p</b>	purl
<b>pm</b>	place marker
<b>p2tog</b>	purl 2 sts together (1 st dec'd)
<b>pssso</b>	pass slipped stitch(es) over
<b>rem</b>	remain(ing)
<b>rep</b>	repeat
<b>rnd</b>	round
<b>RS</b>	right side
<b>sl</b>	slip

<b>ssk</b>	slip next 2 sts individually knitwise, slip them back to left needle in this position, knit them together through the back loops (1 st dec'd)
<b>ssp</b>	slip next 2 sts individually knitwise, slip them back to left needle in this position, purl them together through the back loops (1 st dec'd)
<b>st(s)</b>	stitch(es)
<b>tbl</b>	through the back loop(s)
<b>tog</b>	together
<b>WS</b>	wrong side
<b>yo</b>	yarn over

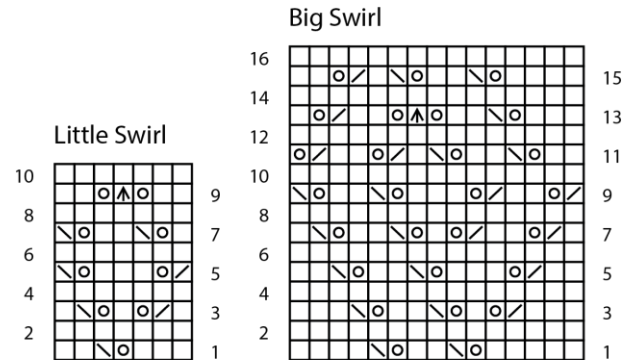

### Key

- knit on RS, purl on WS
- yarn over
- k2tog
- ssk
- sl 1-k2tog-pssso

*Knit, Relax, Smile, Repeat!*

2015 © Universal Yarn, Inc.  
All rights reserved.  
www.universalyarn.com

This pattern may not be reproduced for business, trade or sale.

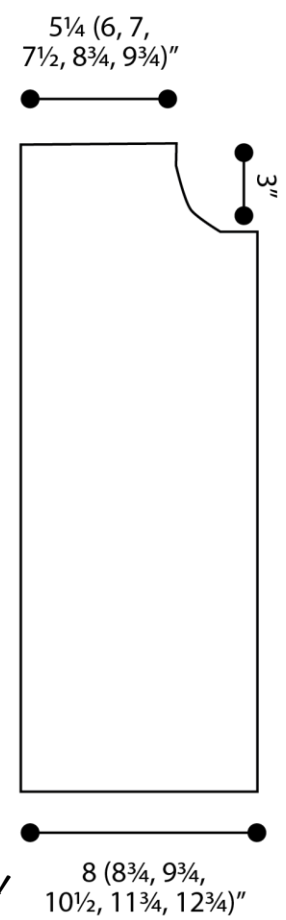
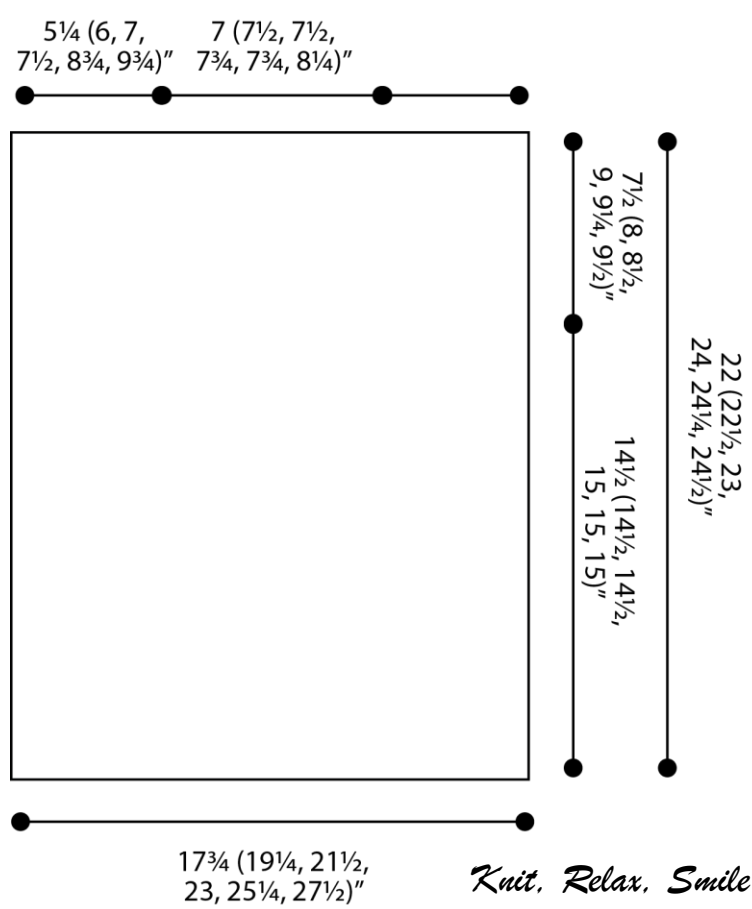
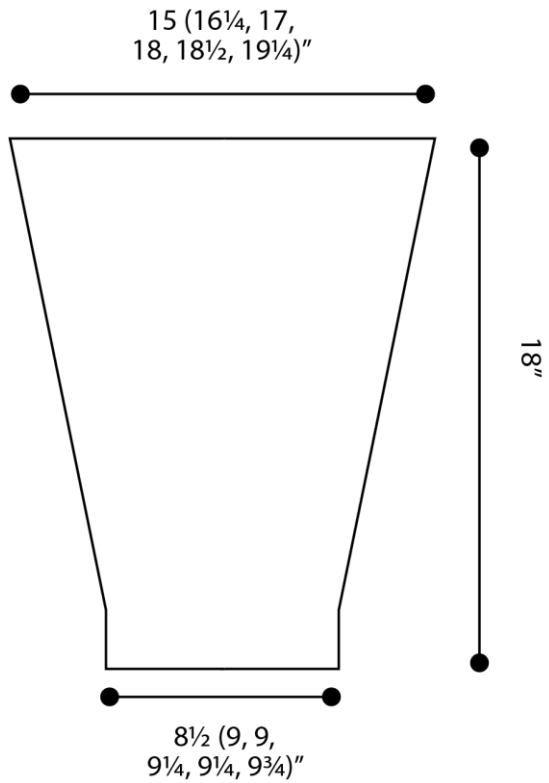

*Knit. Relax. Smile. Repeat!*

2015 © Universal Yarn, Inc.  
All rights reserved.  
www.universalyarn.com

This pattern may not be reproduced for business, trade or sale.