



Pattern Collection: Women



Sideways Sweater

Designed by Universal Yarn Design Team

SIZES

Small (Medium, Large, 1X, 2X, 3X)
Shown in Small size modeled with 1" of ease in the bust

FINISHED MEASUREMENTS

Bust: 34 (38, 42, 46, 50, 54)"

MATERIALS

Universal Yarn Classic Shades Frenzy
(70% acrylic, 30% wool; 100g/158 yds)

- 911 Stranded – 5 (6, 7, 7, 8, 9) balls

Needles: US Size 10 (6 mm) straight *or size needed to obtain gauge*
US Size 9 (5.5 mm) straight, 16" circular (for neck edging)

Notions: Tapestry needle, stitch marker

GAUGE

12 sts x 18 rows = 4" in St st using larger ndl

15 sts x 20 rows = 4" in Slipped Ribbing patt using larger ndl

Save time, check your gauge.

Knit, Relax, Smile, Repeat!

2016 © Universal Yarn, Inc.

All rights reserved.

www.universalyarn.com

This pattern may not be reproduced for business, trade or sale.

PATTERN NOTES

This A line sweater is worked in pieces and seamed. Front, Back, and Sleeves are worked sideways. The hems and cuffs are worked by picking up stitches from the sides of the main pieces and then knit downward.

STITCH GUIDE

Slipped Ribbing

(odd number of sts)

Row 1 (RS): K1, * p1, sl 1 pwise wyib; rep from * to last 2 sts, k1.

Row 2 (WS): * P1, k1; rep from * to last st, p1.
Rep Rows 1-2 for patt.

I-Cord Bind-Off

Cast on 3 sts to first st on left ndl using knitted cast-on. * K2, k2tog tbl (1 st bound-off), slip these 3 sts back to left ndl; rep from * until all sts have been bound-off. Bind off rem 3 I-Cord sts.

FRONT

With larger ndl, cast on 7 sts (all sizes).

Shape Hip

Row 1 (RS): Knit.

Row 2 (WS): Cast on 7 sts, purl to end – 14 sts.

Row 3: Knit.

Rows 4-11: Rep Rows 2-3, 4 more times – 42 sts.

Row 12: Cast on 22 (24, 26, 27, 28, 29) sts – 64 (66, 68, 69, 70, 71) sts.

Work even in St st until piece meas 4 (5, 6, 6¾, 7¾, 8¾)" from last cast-on row, ending with WS row.

Shape Neck

Dec row (RS): Knit to last 3 sts, ssk, k1 – 1 st dec'd.

Dec row (WS): P1, ssp, purl to end – 1 st dec'd.

Cont to dec every row, 18 (18, 18, 20, 20, 20) more times – 44 (46, 48, 47, 48, 49) sts rem.

Inc row (RS): Knit to last st, m1, k1 – 1 st inc'd.

Inc row (WS): P1, m1p, purl to end – 1 st inc'd.

Cont to inc every row, 18 (18, 18, 20, 20, 20) more times – 64 (66, 68, 69, 70, 71) sts.

Work even in St st until piece meas 4 (5, 6, 6¾, 7¾, 8¾)" from last Inc row, ending with RS row.

Shape Hip

Row 1 (WS): Bind off 22 (24, 26, 27, 28, 29) sts, purl to end – 42 sts rem.

Row 2 (RS): Knit.

Row 3 (WS): Bind off 7 sts, purl to end – 35 sts rem.

Row 4 (RS): Knit.

Rows 5-12: Rep Rows 3-4, 4 more times – 7 sts rem.
Bind off rem sts.

Hem

With RS facing and smaller ndl, pick up and knit 71 (79, 87, 93, 101, 109) sts evenly along short end of Sleeve. Knit 3 rows. With larger ndl, bind off all sts over the next RS row, do not fasten off. With last loop on ndl, pick up and purl 70 (78, 86, 92, 100, 108) sts along bind-off edge, working behind sts so that bind-off edge creates a ridge on the RS of the work – 71 (79, 87, 93, 101, 109) sts. Rep Rows 1-2 of Slipped Ribbing patt until Cuff meas 4" from first pick-up edge, ending with WS row. Bind off all sts using I-Cord Bind-off.

BACK

With larger ndl, cast on 7 sts (all sizes).

Shape Hip

Row 1 (RS): Knit.

Row 2 (WS): Cast on 7 sts, purl to end – 14 sts.

Row 3: Knit.

Rows 4-11: Rep Rows 2-3, 4 more times – 42 sts.

Row 12: Cast on 22 (24, 26, 27, 28, 29) sts – 64 (66, 68, 69, 70, 71) sts.

Work even in St st until piece meas 4 (5, 6, 6¾, 7¾, 8¾)" from last cast-on row, ending with WS row.

Shape Neck

Dec row 1(RS): Knit to last 3 sts, ssk, k1 – 1 st dec'd.

Dec row 2(WS): P1, ssp, purl to end – 1 st dec'd.

Dec row 3: Rep Row 1 – 61 (63, 65, 66, 67, 68) sts rem. Work even in St st until piece meas 7½ (7½, 7½, 8, 8, 8)" from last Dec row, ending with RS row.

Inc row 1 (WS): P1, m1p, purl to end – 1 st inc'd.

Inc row 2 (RS): Knit to last st, m1, k1 – 1 st inc'd.

Inc row 3: Rep Row 1 – 64 (66, 68, 69, 70, 71) sts.

Work even in St st until piece meas 4 (5, 6, 6¾, 7¾, 8¾)" from last Inc row, ending with RS row.

Shape Hip

Row 1 (WS): Bind off 22 (24, 26, 27, 28, 29) sts, purl to end – 42 sts rem.

Row 2 (RS): Knit.

Row 3 (WS): Bind off 7 sts, purl to end – 35 sts rem.

Row 4 (RS): Knit.

Rows 5-12: Rep Rows 3-4, 4 more times – 7 sts rem.
Bind off rem sts.

Knit. Relax. Smile. Repeat!

2016 © Universal Yarn, Inc.

All rights reserved.

www.universalyarn.com

This pattern may not be reproduced for business, trade or sale.

SLEEVES

With larger ndl, cast on 4 (4, 3, 3, 3, 3) sts.

Increase Section

Row 1 (RS): Knit.

Row 2 (WS): Purl.

Cast on 4 (4, 3, 3, 3, 3) sts at beg of next 1 (6, 1, 5, 5, 9) RS row(s), then cast on 5 (5, 4, 4, 4, 4) sts at beg of next 6 (2, 8, 5, 5, 2) RS rows – 38 sts, all sizes. Work even in St st for 8 (8, 8½, 8½, 9, 9) more, ending with WS row.

Decrease Section

Bind off 5 (5, 4, 4, 4, 4) sts at beg of next 6 (2, 8, 5, 5, 2) RS rows, then bind off 4 (4, 3, 3, 3, 3) sts at beg of next 1 (6, 1, 5, 5, 9) RS row(s). Bind off rem sts.

Cuff

With RS facing and smaller ndl, pick up and knit 29 (29, 31, 31, 33, 33) sts evenly along short end of Sleeve. Knit 3 rows. With larger ndl, bind off all sts over the next RS row, do not fasten off. With last loop on ndl, pick up and purl 28 (28, 30, 30, 32, 32) sts along bind-off edge, working behind sts so that bind-off edge creates a ridge on the RS of the work – 29 (29, 31, 31, 33, 33) sts. Rep Rows 1-2 of Slipped Ribbing patt until Cuff meas 5" from first pick-up edge, ending with WS row. Bind off all sts using I-Cord Bind-off.

FINISHING

Block pieces to finished measurements. Sew Shoulder seams. Sew Sleeves to body. Sew Sleeve and side seams.

Neck Edging

With smaller circ ndl, pick up and knit 27 (27, 27, 29, 29, 29) sts along Back Neck, 28 (28, 28, 30, 30, 30) sts along Left Front Neck, and 28 (28, 28, 30, 30, 30) sts along Right Front Neck. PM and join to work in the rnd. Purl 1 rnd. Bind off all sts using I-Cord Bind-off.

Weave in ends.

Abbreviations

circ	circular
cont	continue
dec('d)	decrease(d)
inc('d)	increase(d)
k	knit
k2tog	knit 2 stitches together (1 st dec'd)
m	marker
m1	insert left needle from front to back under horizontal strand of yarn lying between st just worked and next st, knit or purl this st through the back loop (1 st inc'd)
m1P	insert left needle from back to front under horizontal strand of yarn lying between st just worked and next st, purl this st through the front loop (1 st inc'd)
meas	measures
ndl	needle
patt	pattern
p	purl
pm	place marker
p2tog	purl 2 sts together (1 st dec'd)
pwisewise	purlwise
rem	remain(ing)
rep	repeat
rnd	round
RS	right side
ssk	slip next 2 sts individually knitwise, slip them back to left needle in this position, knit them together through the back loops (1 st dec'd)
ssp	slip next 2 sts individually knitwise, slip them back to left needle in this position, purl them together through the back loops (1 st dec'd)
st(s)	stitch(es)
St st	Stockinette stitch (knit on RS rows, purl on WS rows; in the rnd, knit every rnd)
WS	wrong side
wyib	with yarn held in back

Knit. Relax. Smile. Repeat!

2016 © Universal Yarn, Inc.

All rights reserved.

www.universalyarn.com

This pattern may not be reproduced for business, trade or sale.

→ indicates direction of knitting

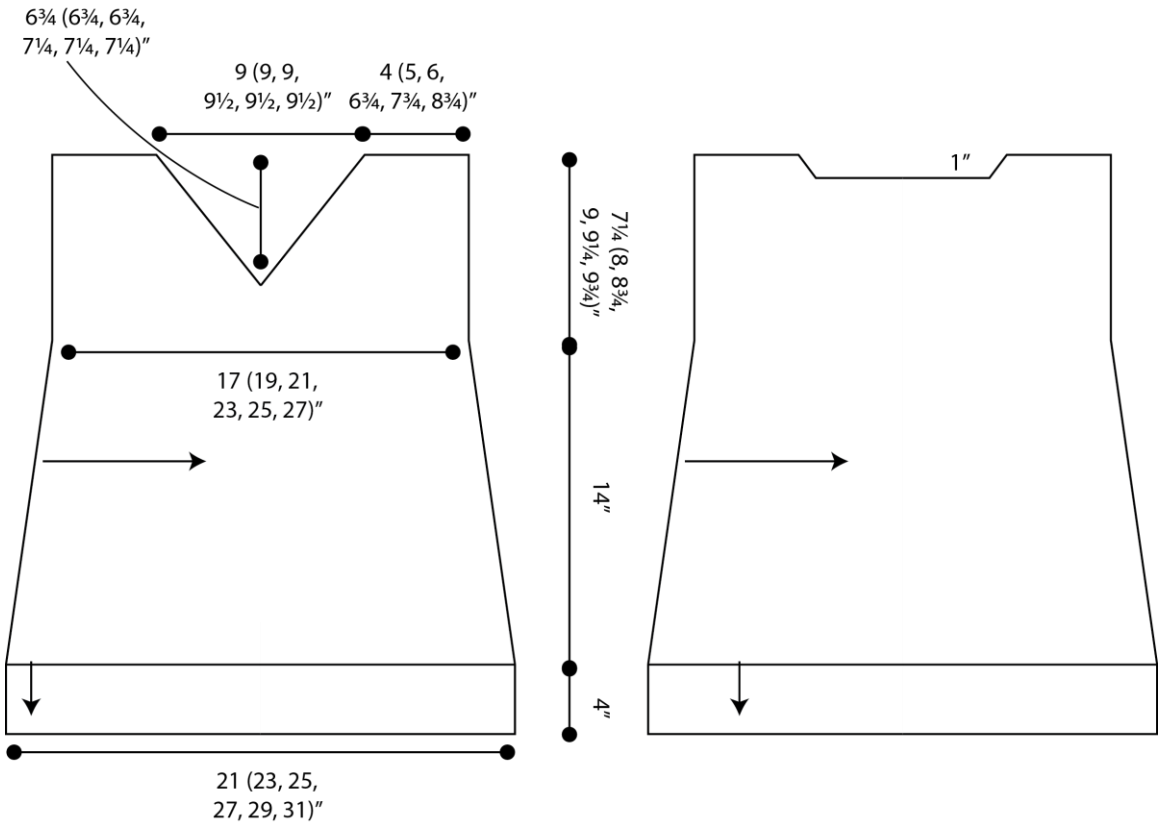
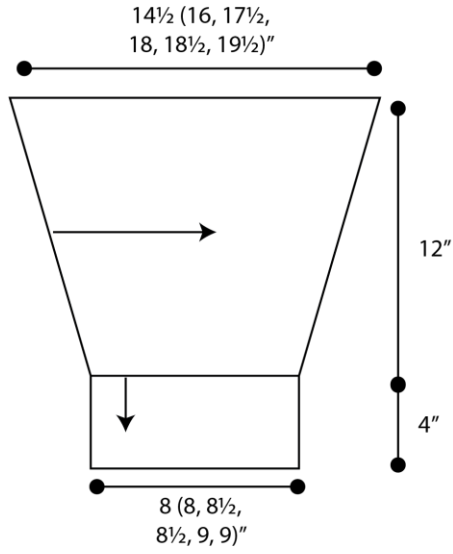

Knit. Relax. Smile. Repeat!

2016 © Universal Yarn, Inc.

All rights reserved.

www.universalyarn.com

This pattern may not be reproduced for business, trade or sale.