



## PATTERN COLLECTION

### Children



#### Cloudborn Cardigan

Designed by Rachel Brockman

#### SKILL

Knitting

#### DIFFICULTY

Easy

#### SIZES

6 mo. (12 mo., 18 mo., 2 yr., 4 yr., 6 yr.)

*Shown in size 2 years.*

#### FINISHED MEASUREMENTS

**Chest Circumference (buttoned):** 16¼  
(18, 20¼, 22, 24¼, 26)''

**Length:** 12½ (13¼, 14, 14¾, 16, 17¼)''

#### MATERIALS

[Universal Yarn Wool/Pop](#) (50% bamboo, 35% super wash wool, 15% polyamide; 100g/284 yds)

- 624 Blueberry - 2 (2, 2, 2, 2, 3) skeins

**Needle:** US Size 5 (3.75 mm) 16'', 24'' circular and set of DPNs (or your preferred needle for knitting small circumferences) *or size needed to obtain gauge*

**Notions:** Tapestry needle, stitch holders or waste yarn, stitch markers, one ½'' button, sewing needle and thread, spare circular needle (for three-needle bind-off)

#### GAUGE

22 sts x 44 rows = 4'' in garter stitch after blocking

**Save time, check your gauge.**

Knit, Relax, Smile, Repeat!

2023 © Universal Yarn, Inc.

[www.universalyarn.com](http://www.universalyarn.com)

All rights reserved. This pattern may not be reproduced for business, trade or sale.

Questions? Contact [patterns@universalyarn.com](mailto:patterns@universalyarn.com)

## PATTERN NOTES

Sunshine and blue skies call for a cute-as-a-button cardigan for your little one. The Cloudborn Cardigan is a versatile layering piece that would look adorable over a folky sundress. Its feature ruffle sleeves let your little one's personality shine through. Our Wool Pop yarn is soft and squishy, making it the perfect match for this garter stitch garment.

The body of this cardigan is knit flat from the bottom up in one piece. The fronts and back are separated at the underarms. The shoulders are joined with the three-needle bind-off. Stitches are then picked up around the armholes and worked in the round, incorporating increases to create the ruffles. Finally, stitches along the neck are picked up and immediately bound off using a 2-stitch I-cord bind-off.

### I-Cord Bind-Off (2-stitch version)

Cast on 2 sts to first st on the left ndl using the knitted cast-on. \* K1, k2tog tbl (1 st bound off), slip these 2 sts back to the left ndl; \* rep from \* until all sts have been bound off. Bind off rem 2 I-Cord sts.

## STITCH GUIDE

### Sleeve Ruffles

*(even number of sts)*

**Rnd 1:** \* [K1, yo] 2 times; rep from \* to end – 2 sts inc'd per rep.

**Even Rnds 2-12:** Purl.

**Rnd 3:** \* K1, yo, k3, yo; rep from \* to end – 2 sts inc'd per rep.

**Rnd 5:** \* K1, yo, k5, yo; rep from \* to end – 2 sts inc'd per rep.

**Rnd 7:** \* K1, yo, k7, yo; rep from \* to end – 2 sts inc'd per rep.

**Rnd 9:** \* K1, yo, k9, yo; rep from \* to end – 2 sts inc'd per rep.

**Rnd 11:** Knit.

## PATTERN BEGINS

### BODY

With 24" circ ndl, cast on 97 (107, 119, 129, 141, 151) sts.

**Set-up Row (WS):** K24 (27, 30, 32, 35, 38) Right Front sts, pm for side, k49 (53, 59, 65, 71, 75) Back sts, pm for side, k24 (27, 30, 32, 35, 38) Left Front sts.

**Row 1 (RS):** Knit.

**Row 2 (WS):** Knit.

Cont in garter st as est'd until piece meas approx. 3 (4, 4, 4, 5, 5)" from cast-on edge, ending with a WS row.

### Shape Body

**Dec Row (RS):** [Knit to 2 sts bef side m, ssk, sl m, k2tog] 2 times, knit to end – 4 sts dec'd, 93 (103, 115, 125, 137, 147) sts rem.

**Next Row (WS):** Knit.

Work even in garter st for 32 (42, 42, 42, 52, 52) rows.

**Next Row (RS):** Rep Dec Row – 4 sts dec'd, 89 (99, 111, 121, 133, 143) sts rem.

Cont even in garter st until piece meas 7¼ (8¼, 8¾, 9¼, 10¼, 11¼)" from cast-on edge, ending with a WS row.

### Right Front

**Separation Row (RS):** Knit across 22 (25, 28, 30, 33, 36) Right Front sts, remove side m, turn. Place rem 67 (74, 83, 91, 100, 107) sts on holder or waste yarn.

Work even in garter st until piece meas 3 (3, 3¼, 3¼, 3½, 3¾)" from Front/Back separation, ending with a WS row.

**Buttonhole Row 1 (RS):** K2, bind off 2 sts, knit to end.

**Buttonhole Row 2 (WS):** Knit to gap, cast on 2 sts, k2 – 1 buttonhole.

Cont even in garter st until piece meas 3½ (3½, 3¾, 3¾, 4, 4¼)" from Front/Back Separation, ending with a WS row.

### Shape Right Front Neck

**Row 1 (RS):** Bind off 4 (5, 5, 5, 5, 6) sts, knit to end – 18 (20, 23, 25, 28, 30) sts rem.

**Row 2 (WS):** Knit.

**Row 3:** Bind off 3 (4, 4, 4, 4, 5) sts, knit to end – 15 (16, 19, 21, 24, 25) sts rem.

**Row 4:** Knit.

**Row 5:** Bind off 3 (3, 4, 4, 4, 4) sts, knit to end – 12 (13, 15, 17, 20, 21) sts rem.

**Row 6:** Knit.

**Row 7:** K1, k2tog, knit to end – 1 st dec'd, 11 (12, 14, 16, 19, 20) sts rem.

**Row 8:** Knit.

**Rows 9-12:** Rep Rows 7-8, 2 more times – 2 sts dec'd, 9 (10, 12, 14, 17, 18) sts rem.

Cont even in garter st, if necessary, until piece meas 4¾ (5, 5¼, 5½, 5¾, 6)" from Front/Back Separation, ending with a WS row. Place sts on holder or waste yarn.

Knit, Relax, Smile, Repeat!

2023 © Universal Yarn, Inc.

[www.universalyarn.com](http://www.universalyarn.com)

All rights reserved. This pattern may not be reproduced for business, trade or sale.

Questions? Contact [patterns@universalyarn.com](mailto:patterns@universalyarn.com)

Return held Back and Left Front sts to ndl, ready to work a RS row.

### Back

**Separation Row (RS):** Knit across 45 (49, 55, 61, 67, 71) Back sts to m, remove side m, turn. Place rem 22 (25, 28, 30, 33, 36) Left Front sts on holder or waste yarn.

Work even in garter st until piece meas 4¾ (5, 5½, 5½, 5¾, 6)” from Front/Back Separation, ending with a RS row. Place sts on holder or waste yarn.

**Next Row (WS):** K9 (10, 12, 14, 17, 18) Left Back sts, bind off center 27 (29, 31, 33, 33, 35) neck sts, k9 (10, 12, 14, 17, 18) Right Back sts. Place Left Back and Right Back sts on holder or waste yarn.

Return held Left Front sts to ndl, ready to work a RS row.

### Left Front

Work even in garter st until piece meas 3½ (3½, 3¾, 3¾, 4, 4¾)” from Front/Back Separation, ending with a RS row.

### Shape Left Front Neck

**Row 1 (WS):** Bind off 4 (5, 5, 5, 5, 6) sts, knit to end – 18 (20, 23, 25, 28, 30) sts rem.

**Row 2 (RS):** Knit.

**Row 3:** Bind off 3 (4, 4, 4, 4, 5) sts, knit to end – 15 (16, 19, 21, 24, 25) sts rem.

**Row 4:** Knit.

**Row 5:** Bind off 3 (3, 4, 4, 4, 4) sts, knit to end – 12 (13, 15, 17, 20, 21) sts rem.

**Row 6:** Knit to last 3 sts, ssk, k1 – 1 st dec'd, 11 (12, 14, 16, 19, 20) sts rem.

**Row 7:** Knit.

**Rows 8-11:** Rep Rows 6-7, 2 more times – 2 sts dec'd, 9 (10, 12, 14, 17, 18) sts rem.

Cont even in garter st, if necessary, until piece meas 4¾ (5, 5½, 5½, 5¾, 6)” from Front/Back Separation, ending with a WS row. Place sts on holder or waste yarn.

### Join Shoulders

Place held Left Back sts onto a spare circ ndl. With RS facing together, join Left Front and Left Back shoulder sts using the three-needle bind-off. Rep for Right Front and Right Back shoulder sts.

### Sleeve Ruffles

*Note: Change from DPNs to 16” and/or 24” circ ndl as there becomes too many sts to fit comfortably on DPNs.*

With DPNs or your preferred ndl for knitting small circumferences, RS facing, and beginning at the center of the underarm, pick up and knit 52 (54, 56, 60, 62, 66) sts evenly around the armhole. PM and join to knit in the rnd.

Work Rnds 1-12 of Sleeve Ruffle patt. Patt will be repeated 26 (27, 28, 30, 31, 33) times across each rnd – 260 (270, 280, 300, 310, 330) sts inc'd, 312 (324, 336, 360, 372, 396) sts.

Bind off all sts kwise. Rep for opposite armhole.

### FINISHING

Gently wash and block to finished measurements. Weave in ends. Using sewing needle and thread, sew ½” button to Left Front, opposite buttonhole.

### Neck Edging

With 16” circ and RS facing, beg at Right Front neck edge. Pick up and knit 55 (63, 67, 73, 73, 79) sts evenly around neck. Bind off all sts using the I-Cord Bind-off. Weave in rem ends.

### Abbreviations

approx	approximately
beg	begin(ning)
circ	circular
cont	continue
dec('d)	decrease(d)
dpn(s)	double pointed needle(s)
est'd	established
garter st	knit every row
inc('d)	increase(d)
k	knit
k2tog	knit 2 stitches together (1 st dec'd)
kwise	knitwise
m	marker
meas	measures
ndl	needle
p	purl
patt	pattern
pm	place marker
rem	remain(ing)
rep	repeat
rnd(s)	round(s)
RS	right side
sl	slip
ssk	slip next 2 sts individually knitwise, slip them back to left needle in this position, knit them together through the back loops (1 st dec'd)
st(s)	stitch(es)
WS	wrong side
yo	yarn over

Knit, Relax, Smile, Repeat!

2023 © Universal Yarn, Inc.

[www.universalyarn.com](http://www.universalyarn.com)

All rights reserved. This pattern may not be reproduced for business, trade or sale.

Questions? Contact [patterns@universalyarn.com](mailto:patterns@universalyarn.com)

# Sleeve Ruffles

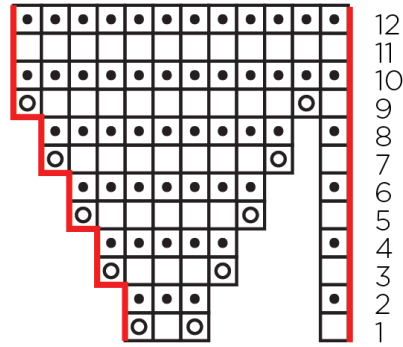

## Key

- pattern repeat
- knit
- purl
- yo

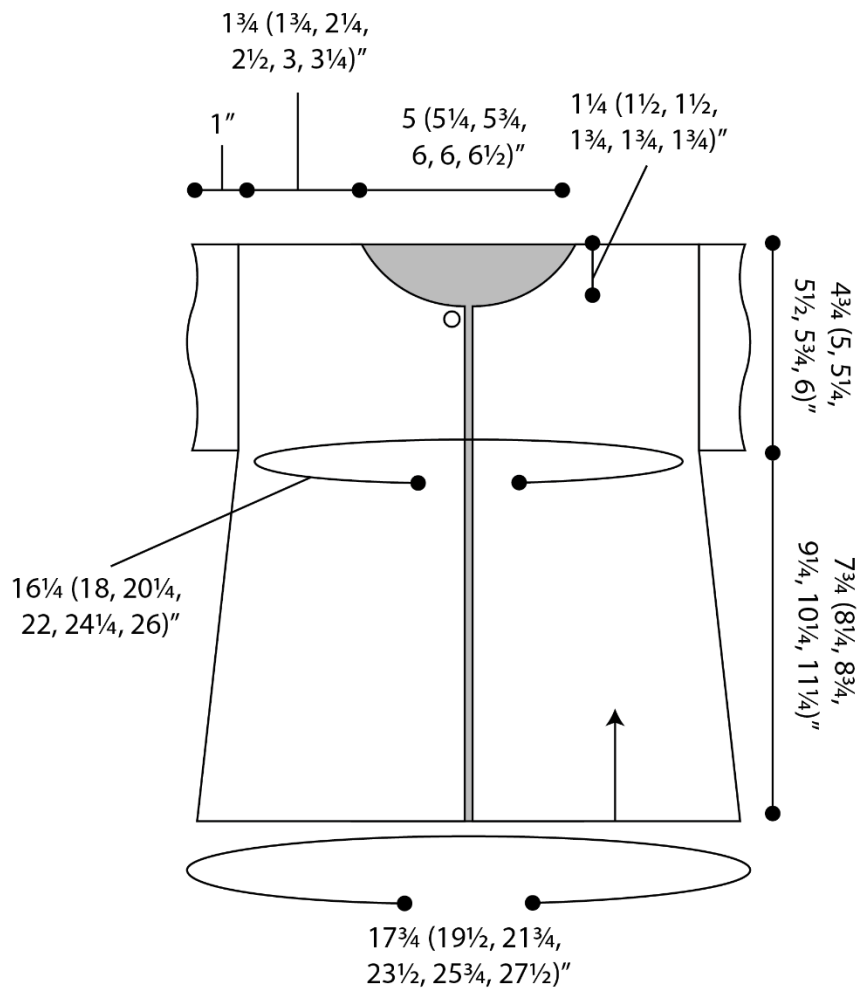

Knit, Relax, Smile, Repeat!

2023 © Universal Yarn, Inc.

[www.universalyarn.com](http://www.universalyarn.com)

All rights reserved. This pattern may not be reproduced for business, trade or sale.

Questions? Contact [patterns@universalyarn.com](mailto:patterns@universalyarn.com)