



SPARE PARTS LIST

SURFACE PREPARATION EQUIPMENT

PG 450, 2014-06

C PG 450
Chassi

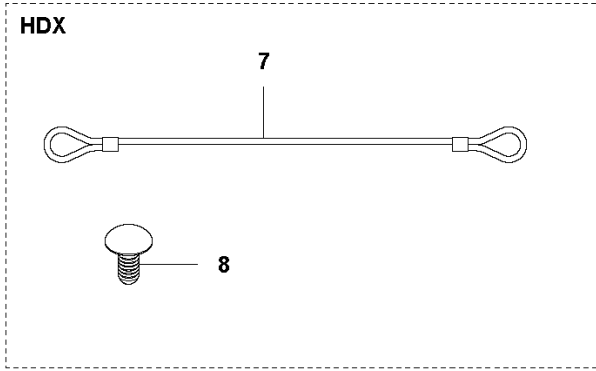
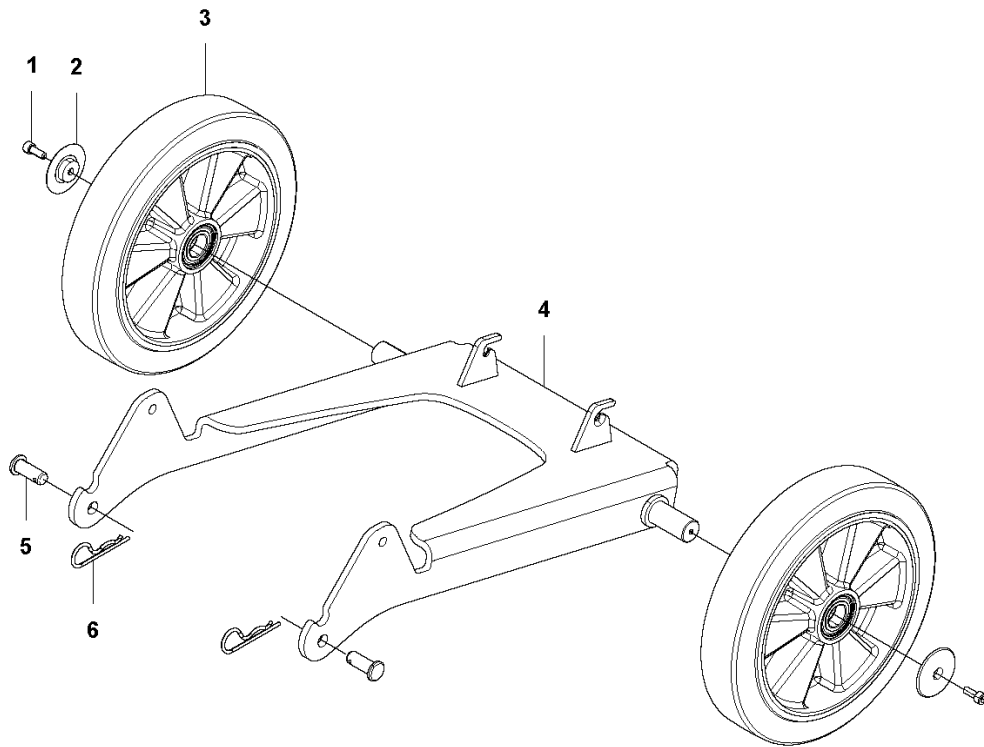

Ref	Part No	Description	Remark	QTY KIT
1	725 53 70-51	SCREW IHSCM		2
2	575 39 51-01	WASHER		2
3	502 54 50-01	WHEEL		2
4	585 10 92-01	FRAME ASSY		1
5	721 85 68-01	CLEVIS PIN		2
5	585 51 91-03	CLEVIS PIN	HDX variant only	2
6	721 68 02-51	SPRING COTTER		2
7	586 29 64-01	WIRE	HDX variant only	4
8	586 82 91-01	RIVET	HDX variant only	6

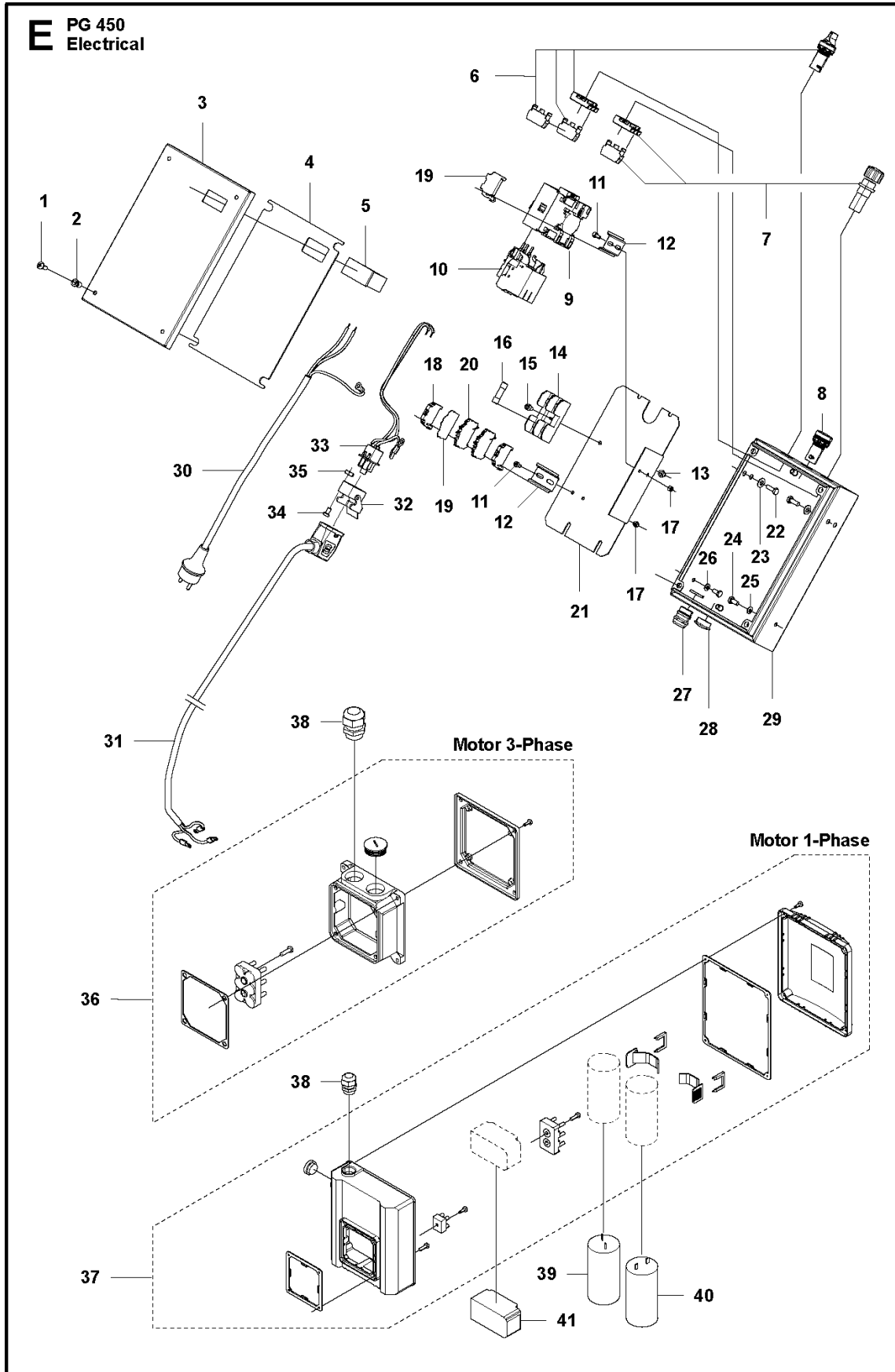

Ref	Part No	Description	Remark	QTY KIT
1	724 13 68-51	SCREW CRPANM		4
2	521 88 66-01	RIVET		4
3	586 47 43-01	LID		1
3	586 47 43-03	LID	HDX version only	1
4	586 46 70-01	SEALING	Attach with double-sided tape	1
5	584 29 63-01	HOUR METER		1
6	586 99 15-01	SWITCH KIT		1
7	586 99 16-01	SWITCH KIT		1
8	584 29 71-01	LAMP		1
8	584 29 71-02	LAMP		1
9	585 36 58-01	CONTACTOR	200-230V, 50/60Hz	1
9	585 36 58-02	CONTACTOR	100-120V, 60Hz	1
9	586 99 18-01	CONTACTOR	100-120V, 50Hz	1
10	584 29 78-02	RELAY	3 phase	1
10	584 29 78-01	RELAY	1 phase, 220-240V, 60Hz	1
10	580 62 35-02	PROTECTION	1 phase, 220-240V, 50Hz	1
10	580 62 35-01	PROTECTION	1 phase, 100-120V, 60Hz	1
10	584 29 78-05	RELAY	1 phase, 100-120V, 50Hz	1
11	725 53 25-01	SCREW IHSCM		4
12	522 74 70-01	RAIL		2
13	731 23 16-01	HEXAGON NUT		1
14	525 88 26-01	FUSE HOLDER		1
15	725 53 64-55	SCREW IHSCM		1
16	525 63 81-01	FUSE		2
17	732 25 14-01	HEXAGON LOCKING NUT		4
18	585 36 61-05	TERMINAL BLOCK		3
19	585 36 61-03	TERMINAL BLOCK		1
19	585 36 61-07	TERMINAL BLOCK	US 1ph 100-120V	1
20	585 61 35-01	TERMINAL BLOCK	2pcs for 1ph and 3pcs for 3ph machines	
20	585 36 61-01	TERMINAL BLOCK	1 phase, US, 120V	2
21	585 59 38-01	PLATE		1
22	725 24 51-71	SCREW EHHM		4
23	734 11 63-01	WASHER		4
24	725 23 66-71	SCREW EHHM		2
25	734 11 52-01	WASHER		1
26	735 21 53-01	LOCKWASHER		1
27	575 48 98-01	GROMMET		1
27	587 10 12-01	GROMMET		1
28	586 58 69-01	PLUG		1
28	586 58 69-02	PLUG	US only	1
29	586 47 42-01	BOX		1
29	586 47 42-02	BOX	HDX version only	1
30	586 23 68-03	CABLE	1 phase	1
30	586 23 68-02	CABLE	1 phase, AUS	1
30	586 23 68-01	CABLE	1 phase, CH	1
30	586 23 68-08	CABLE	1 phase, BR	1
30	586 23 68-12	CABLE	1 phase, US, 120V	1
30	586 23 68-13	CABLE	1 phase, US, 240V	1
30	586 23 68-06	CABLE	1 phase, UK	1
30	586 23 78-05	CABLE	3 phase, JP	1
31	585 63 81-03	CABLE	1 phase	1
31	585 63 81-10	CABLE	1 phase, US/CAN, 240V	1
31	585 63 81-11	CABLE	1 phase, US/CAN, 120V	1
31	585 63 81-07	CABLE	3 phase, JP	1
32	587 06 15-01	CONNECTOR		1
33	585 36 66-02	CONNECTOR		1
34	725 52 24-01	SCREW		2
35	732 25 10-01	HEXAGON LOCKING NUT		2
36	587 17 39-02	ELECTRONIC BOX	3 phase	1
37	587 17 39-01	ELECTRONIC BOX	1 phase	1
38	587 17 42-02	GROMMET	3 phase	1
38	587 17 42-01	GROMMET	1 phase	1
38	587 16 33-01	GROMMET	1 phase, US, 120V	1

Ref	Part No	Description	Remark	QTY KIT
39	587 17 45-01	CAPACITOR	230V, 50/60Hz	1
39	587 17 45-02	CAPACITOR	110V, 50/60Hz	1
40	587 17 44-01	CAPACITOR	230V, 50Hz	1
40	587 17 44-02	CAPACITOR	230V, 60 Hz	1
40	587 17 44-03	CAPACITOR	110V, 50/60Hz	1
41	587 17 43-01	SWITCH	230V, 50 Hz	1
41	587 17 43-02	SWITCH	208-230V, 60Hz	1
41	587 17 43-03	SWITCH	110V, 50-60 Hz	1

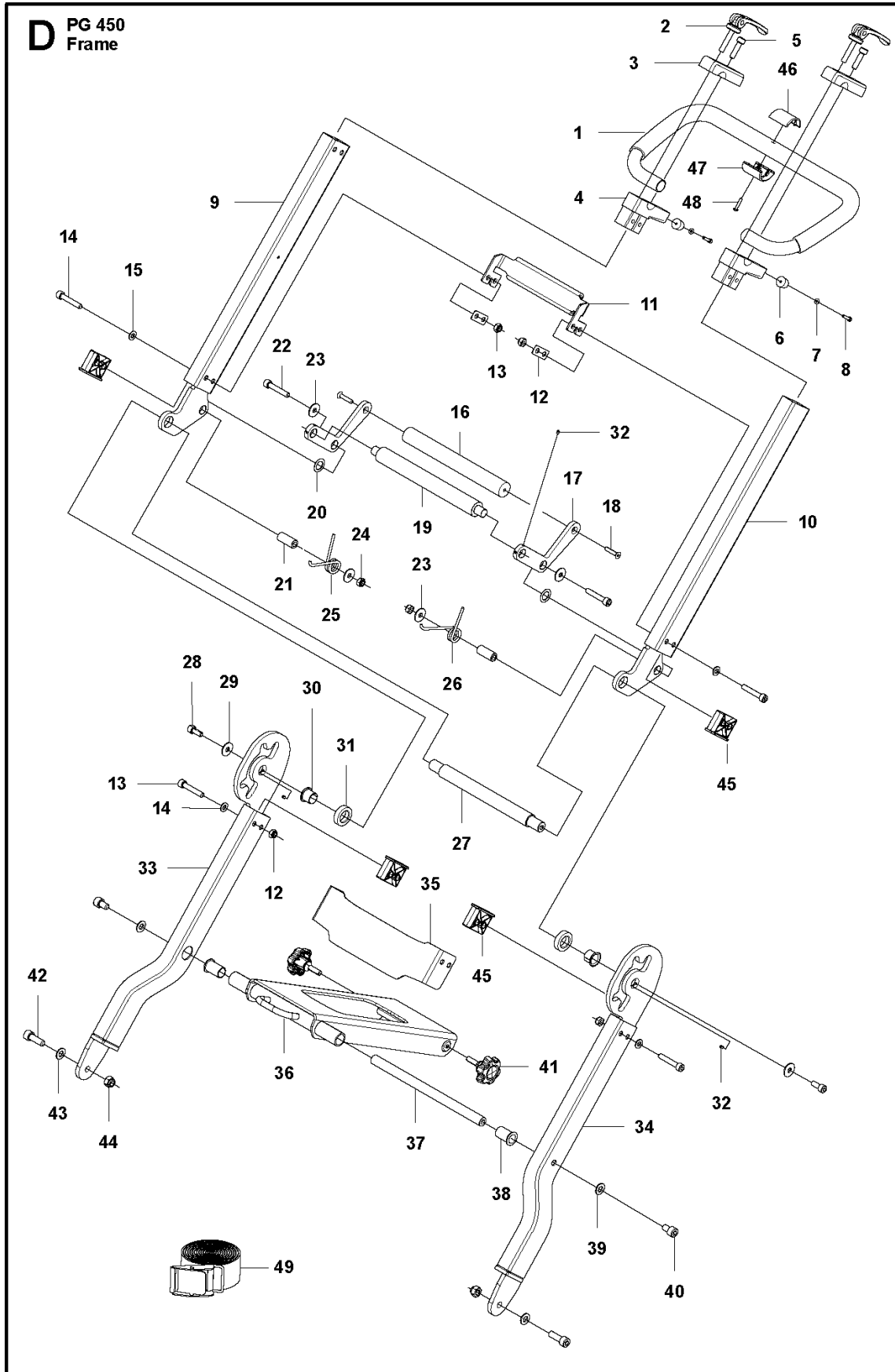

Ref	Part No	Description	Remark	QTY KIT
1	585 14 40-01	HANDLE		1
2	585 12 92-01	LOCKING HANDLE		2
3	585 51 66-01	BRACKET		2
4	585 51 67-01	BRACKET		2
5	725 54 55-21	SCREW IHSCM		2
6	585 51 68-01	RUBBER SHOE		2
7	734 11 36-01	WASHER		2
8	725 52 95-01	SCREW IHSCM		2
9	585 57 35-03	FORK		1
10	585 57 35-04	FORK		1
11	585 38 28-01	BRACKET		1
12	585 38 31-01	WASHER		2
13	732 25 18-01	HEXAGON LOCKING NUT		8
14	725 54 60-01	SCREW IHSCM		8
15	734 11 63-01	WASHER		8
16	585 13 37-01	HANDLE		1
17	585 13 33-01	PLATE		2
18	725 63 74-51	SCREW		2
19	585 13 38-01	ROD		1
20	585 41 62-01	WASHER		2
21	585 38 33-01	SLEEVE		2
22	725 54 61-01	SCREW IHSCM		2
23	734 11 65-41	WASHER		4
24	732 25 18-01	HEXAGON LOCKING NUT		2
25	585 41 73-01	SPRING		1
26	585 41 61-01	SPRING		1
27	585 13 36-01	TUBE		1
28	725 54 51-01	SCREW IHSCM		2
29	734 11 65-41	WASHER		2
30	585 41 60-01	BUSH		2
31	585 13 35-01	SPACER		2
32	728 82 85-01	SCREW IHSETM		6
33	585 12 74-01	FORK		1
34	585 12 74-02	FORK		1
35	585 38 30-01	BRACKET		1
35	585 38 30-03	BRACKET	HDX variant only	1
36	585 10 97-01	SUPPORT		1
37	585 12 90-02	TUBE		1
38	585 12 91-01	BUSH		2
39	734 11 72-01	WASHER		2
40	725 54 89-01	SCREW IHSCM		2
41	586 91 28-01	KNOB		2
42	725 54 95-01	SCREW IHSCM		2
43	734 11 72-01	WASHER		2
44	732 25 20-01	HEXAGON LOCKING NUT		2
45	585 13 29-01	SPACER		4
46	587 15 85-01	COVER		1
47	587 15 86-01	COVER		1
48	729 52 61-71	SCREW CRPANT		1
49	584 61 87-01	STRAP		1

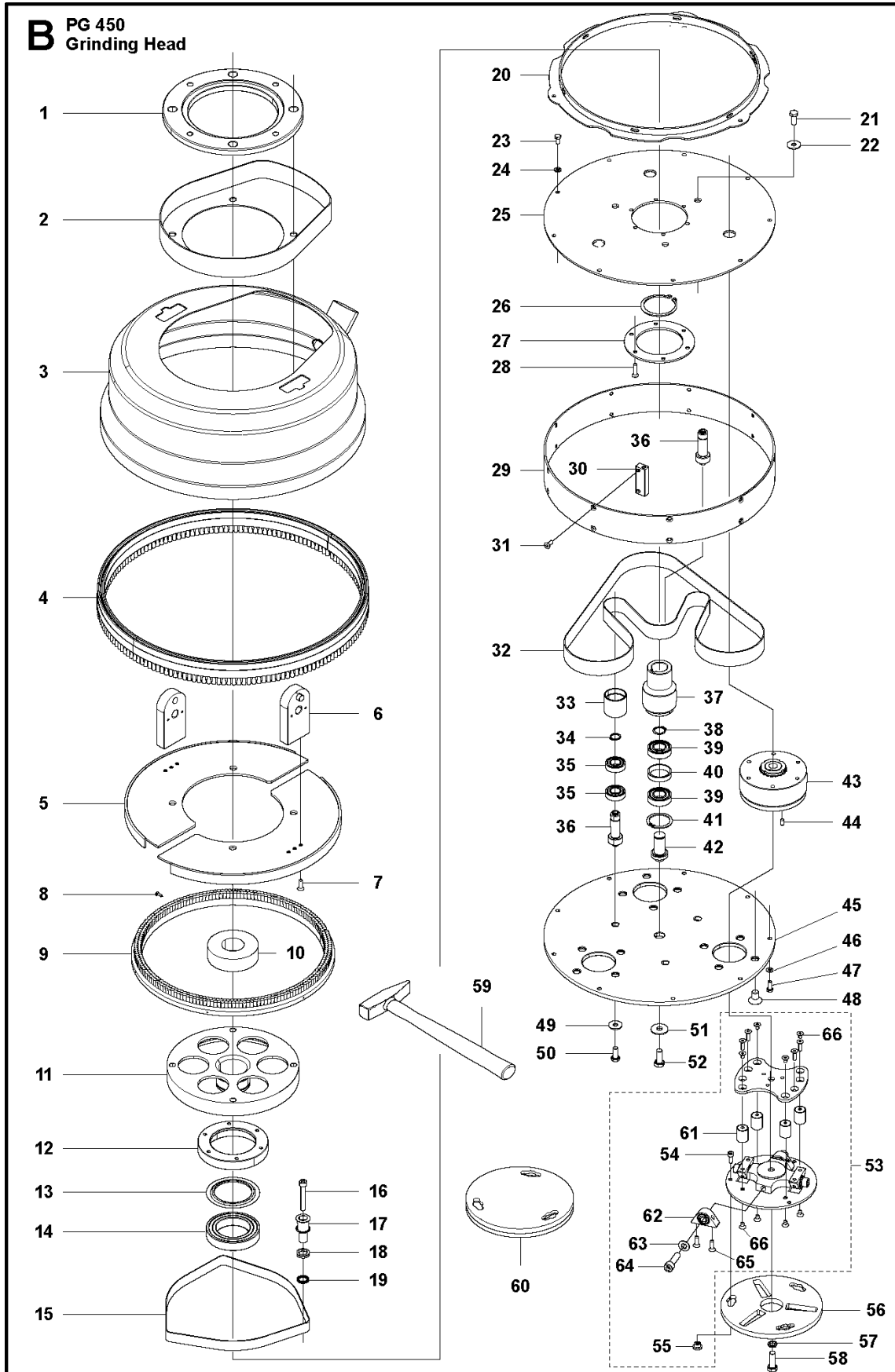

Ref	Part No	Description	Remark	QTY	KIT
1	585 08 33-02	SPACER		1	
2	584 85 10-01	GUIDE		1	
3	585 08 34-01	DUST COVER		1	
4	585 13 84-05	BRUSH		1	
5	586 85 24-01	MOUNTING PLATE		2	
6	585 54 03-01	BRACKET		2	
6	585 54 03-02	BRACKET	HDX variant only	2	
7	725 63 70-51	SCREW IHCSFM		6	
8	729 52 81-01	SCREW CRPANT		7	
9	584 83 27-02	BRUSH		1	
10	585 41 78-01	SEAL		1	
11	584 82 95-01	PLATE		1	
12	584 82 91-01	HOUSING		1	
13	584 82 92-01	SEAL		1	
14	502 56 26-01	BALL BEARING		1	
15	584 82 98-01	BELT		1	
16	725 54 62-01	SCREW IHSCM		3	
17	584 83 94-01	SHAFT		3	
18	740 68 11-21	V-RING		3	
19	584 82 84-01	RADIAL SEAL		3	
20	584 83 24-01	COVER		1	
21	725 24 51-71	SCREW EHHM		3	
22	734 11 65-41	WASHER		3	
23	725 23 68-71	SCREW EHHM		9	
24	734 11 52-01	WASHER		9	
25	584 82 83-01	LID		1	
26	502 53 96-01	CIRCLIP		1	
27	584 82 94-01	COVER		1	
28	725 63 72-51	SCREW IHCSFM		6	
29	584 83 81-01	COVER		1	
30	584 83 79-01	BOSS		9	
31	725 63 68-51	SCREW IHCSFM		18	
32	584 83 16-01	BELT		1	
33	584 82 87-01	PULLEY		2	
34	735 31 19-00	CIRCLIP		2	
35	584 82 88-01	BALL BEARING		4	
36	584 82 86-01	SHAFT		3	
37	584 83 06-01	PULLEY		1	
38	735 31 22-00	CIRCLIP		1	
39	584 83 04-01	BALL BEARING		2	
40	584 83 05-01	SPACER		1	
41	735 31 38-10	CIRCLIP		1	
42	584 83 02-01	SHAFT		1	
43	584 83 07-01	PULLEY ASSY		3	
44	720 13 49-50	PARALLEL PIN		9	
45	584 83 17-01	LID		1	
46	734 11 52-01	WASHER		9	
47	725 23 68-71	SCREW EHHM		9	
48	584 83 23-01	SCREW IHCSFM		12	
49	734 11 65-41	WASHER		3	
50	725 24 51-71	SCREW EHHM		3	
51	734 11 74-41	WASHER		1	
52	725 24 93-71	SCREW EHHM		1	
53	584 81 57-01	HOLDER ASSY		3	
54	725 53 68-51	SCREW IHSCM		9	53
55	502 53 44-01	LOCK		9	53
56	584 85 02-01	HOLDER		3	
57	735 11 73-01	SPRING WASHER		3	
58	725 24 95-71	SCREW EHHM		3	
59	522 03 97-01	HAMMER		1	
60	585 59 17-01	HOLDER		3	
61	584 81 61-01	ABSORBER		1	53
62	584 81 64-01	CONNECTION		12	53
63	734 11 72-01	WASHER		12	53
64	725 54 97-01	SCREW IHSCM		12	53
65	725 63 70-51	SCREW IHCSFM		12	53
66	725 63 64-51	SCREW IHCSFM		24	53

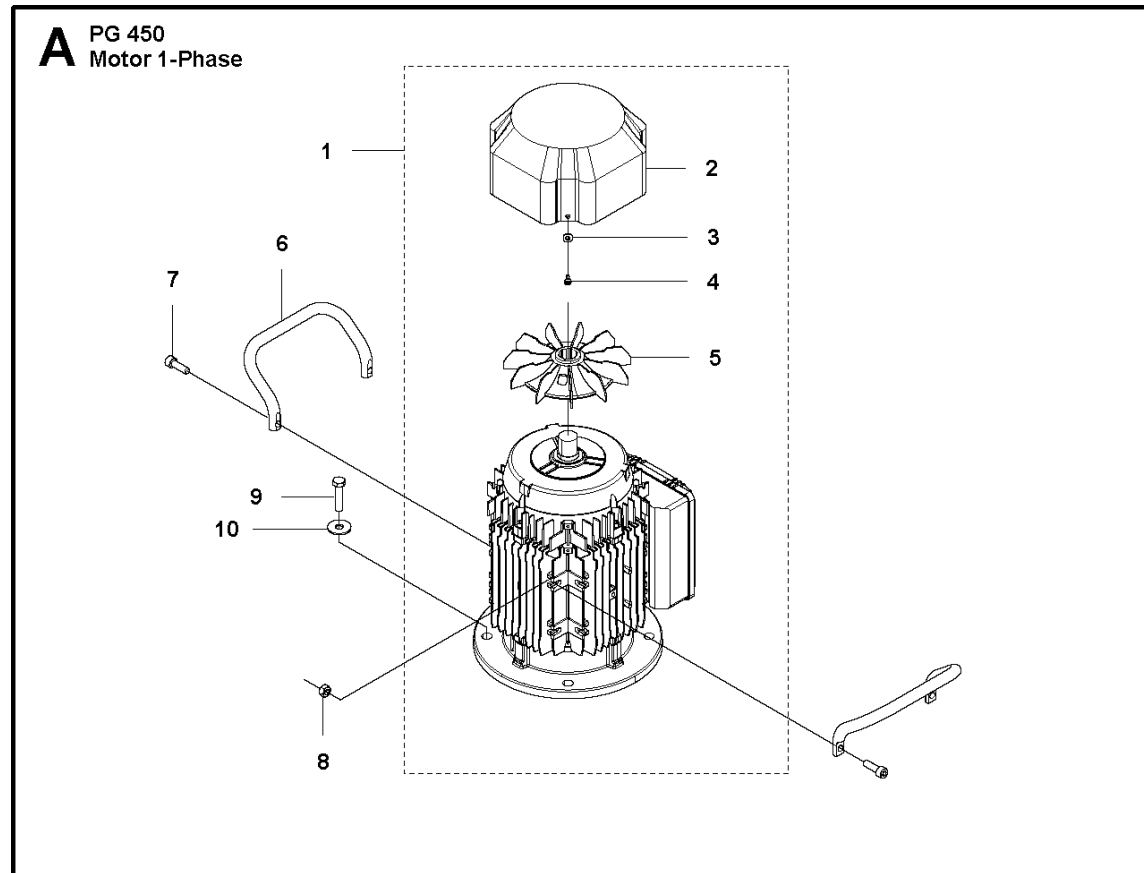

MOTOR

PG 450, 2014-06

Ref	Part No	Description	Remark	QTY	KIT
1	585 19 19-01	MOTOR	1 phase, 230V, 50Hz	1	
1	585 19 19-02	MOTOR	1 phase, 230V, 60Hz	1	
1	585 19 21-01	MOTOR	1 phase, 110V, 60Hz	1	
1	585 19 22-01	MOTOR	1 phase, 110V, 50Hz	1	
2	587 17 46-01	FAN COVER		1	1
3	734 11 46-01	WASHER		4	1
4	724 13 23-01	SCREW CRPANM		4	1
5	587 17 47-01	FAN		1	1
6	585 42 33-01	HANDLE		2	
7	725 54 51-01	SCREW IHSCM		4	
8	731 23 18-01	HEXAGON NUT		4	
9	725 25 42-71	SCREW EHHM		4	
10	734 11 78-01	WASHER		4	

A PG 450
Motor 3-Phase

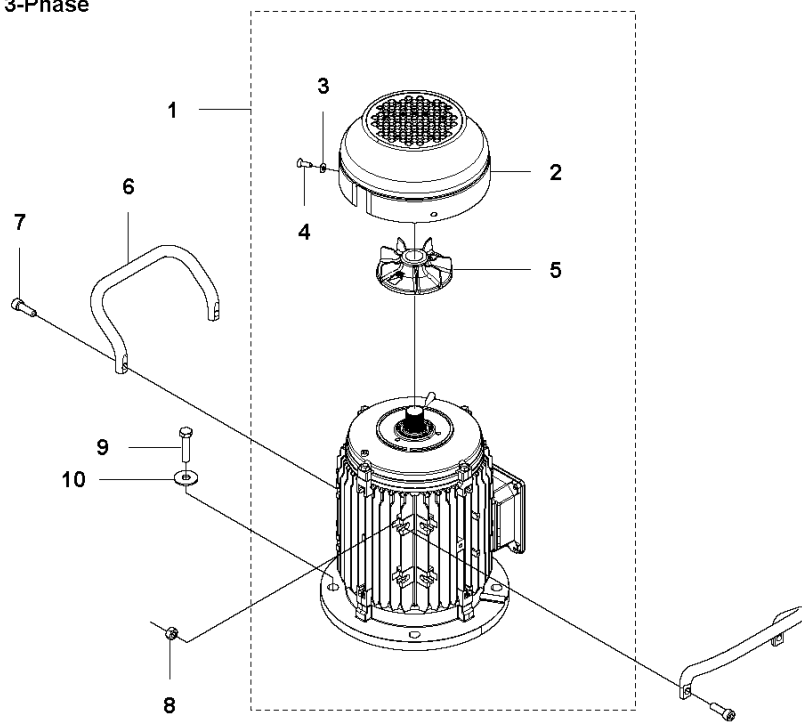

MOTOR

PG 450, 2014-06

Ref	Part No	Description	Remark	QTY	KIT
1	585 19 23-01	MOTOR	JP, 3 phase, 200V, 50/60Hz	1	
2	587 17 46-03	FAN COVER		1	1
3	734 11 46-01	WASHER		3	1
4	724 13 23-01	SCREW CRPANM		3	1
5	587 17 47-04	FAN		1	1
6	585 42 33-01	HANDLE		2	
7	725 54 51-01	SCREW IHSCM		4	
8	731 23 18-01	HEXAGON NUT		4	
9	725 25 42-71	SCREW EHHM		4	
10	734 11 78-01	WASHER		4	