

M-1 COMPLETE CORE RIG

Great for the General Contractor
#1 Selling Rig in the U.S.A.



M-1 Angle Combination Stand Only		
Part #	Cat #	List Price
4245062 for Milwaukee	01799	\$1,156



M-1 Standard Combination Stand Only		
Part #	Cat #	List Price
4245065	01801	\$954
4245092 for Weka, CB733 & CB744	07810	935

Motor mount plate for Milwaukee motors		
Part #	Cat #	List Price
4648029	02159	\$139

Special Combo Stand for Milwaukee motors		
Part #	Cat #	List Price
4241214	37567	\$1,858



M-1 Angle Anchor Stand Only		
Part #	Cat #	List Price
4246070	01809	\$1,017



M-1 Standard Anchor Stand Only		
Part #	Cat #	List Price
4246055	01806	\$829
4243055 for Weka, CB733 & CB744	77909	813



M-1 Complete Combination Rig with CB744 motor (control panel not needed)



M-1 Complete Anchor Rig with CB733 motor



MADE IN THE U.S.A.

10" Standard Bit Capacity, 14" w/Spacers
14" Standard Bit Capacity (CB733, CB744)

Features & Benefits:

- 2-1/2" square column (mast) with black oxidized finish
- 6" wheels for easy mobility
- Dual switch/outlet control panel with amp meter (except for CB733 and CB744 models with LED amp meter)
- Vacuum pump for quick mounting to flat surface without drilling an anchor hole (included with combination rig)
- 4 leveling screws on the base
- Slide handle allows for drilling in tight areas
- Combination base changes from vacuum to anchor base
- Ceiling jack helps keep the rig in place as a backup for anchoring or vacuuming the base down (used with a brace piece-2 x 4 or other material)

M-1

COMPLETE M-1 COMBINATION DRILL RIGS WITH VACUUM PUMP & CONTROL PANEL								INCLUDES:
Model #	Motor	Power	Motor RPM	Combo Rig Part #	Cat #	Product Weight (lbs.)	List Price	
M1C-20-CB733-V	Core Bore CB733	20 amp	550/1000/1600	4245112	85327	136	\$3,237	Combo Stand, Motor, Vacuum Pump, Control Panel
M1C-20-MW4004-V	Milwaukee	20 amp	300/600	4245048	01784	127	3,302	
M1C-20-MW4096-V	Milwaukee	20 amp	450/900	4245059	01794	127	3,302	
M1C-20-MW4005-V	Milwaukee	20 amp	600/1200	4245049	01785	127	3,302	
M1C-15-MW4097-V	Milwaukee	15 amp	500/1000	4245051	01787	127	3,255	
M1C-23-DK22-V	Weka DK22	23 amp	550/1120/1680	4245053	47173	127	4,643	
M1C-23-DK22S-V	Weka DK22S	23 amp	800/1640/2430	4245046	50138	127	4,643	
COMPLETE M-1 COMBINATION DRILL RIGS WITHOUT CONTROL PANEL (Control panel not needed - Includes LED meter and on/off switch on motor)								
M1C-20-CB733WO	Core Bore CB733	20 amp	550/1000/1600	4245115	39317	108	\$2,881	Combo Stand, Motor, Vacuum Pump
M1C-25-CB744WO	Core Bore CB744*	25 amp	385/530/975/1340	4245104	81050	110	3,768	
COMPLETE M-1 COMBINATION DRILL RIGS WITHOUT VACUUM PUMP								
M1C-20-MW4004	Milwaukee	20 amp	300/600	4245072	75375	108	\$2,914	Combo Stand, Motor, Control Panel
M1C-20-MW4096	Milwaukee	20 amp	450/900	4245073	67092	108	2,914	
M1C-20-MW4005	Milwaukee	20 amp	600/1200	4245074	74708	108	2,914	
M1C-15-MW4097	Milwaukee	15 amp	500/1000	4245075	70125	108	2,835	
M1C-23-DK22	Weka DK22	23 amp	550/1120/1680	4245077	71962	117	4,261	
M1C-23-DK22S	Weka DK22S	23 amp	800/1640/2430	4245078	72583	117	4,261	
COMPLETE M-1 ANCHOR DRILL RIGS								
M1A-20-MW4004	Milwaukee	20 amp	300/600	4245009	47162	91	\$2,767	Anchor Stand, Motor, Control Panel
M1A-20-MW4096	Milwaukee	20 amp	450/900	4245003	01776	91	2,767	
M1A-20-MW4005	Milwaukee	20 amp	600/1200	4245010	01782	91	2,767	
M1A-15-MW4097	Milwaukee	15 amp	500/1000	4245006	01780	91	2,686	
M1A-23-DK22	Weka DK22	23 amp	550/1120/1680	4245008	52339	95	4,112	
M1A-23-DK22S	Weka DK22S	23 amp	800/1640/2430	4245011	66795	95	4,112	
COMPLETE M-1 ANCHOR DRILL RIGS WITHOUT CONTROL PANEL (Control panel not needed - Includes LED meter and on/off switch on motor)								
M1A-20-CB733WO	Core Bore CB733	20 amp	550/1000/1600	4245114	39195	98	\$2,304	Anchor Stand, Motor
M1A-25-CB744	Core Bore CB744*	25 amp	385/530/975/1340	4245103	81054	98	3,184	

CB733 and CB744 motors do not require a control panel for operation. These motors include LED amp meter and on/off switch.

Over a Thousand Different Ways to Build Your Custom Rig!

Looking for a Quick Disconnect on Your M-1 Rig? Use Part # 4699961, Cat # 469830

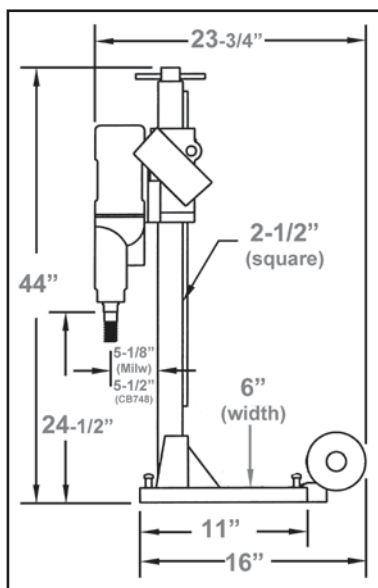

M-1 ANCHOR

Location to drill anchor hole = 12" measured from the center of the motor spindle to the center of the anchor slot on base

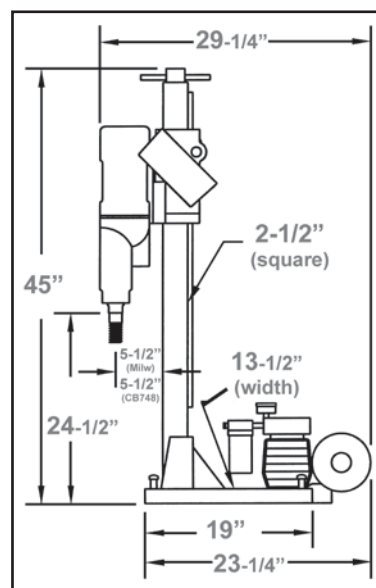

M-1 COMBINATION

Location to drill anchor hole = 12-1/2" measured from the center of the motor spindle to the center of the anchor/vacuum slot on base



Vacuum base gasket provides a seal to keep the base vacuumed to the surface