

GorillaConcreteTools

GCT-8 Series III Early Entry

Product Manual



Parts Diagram

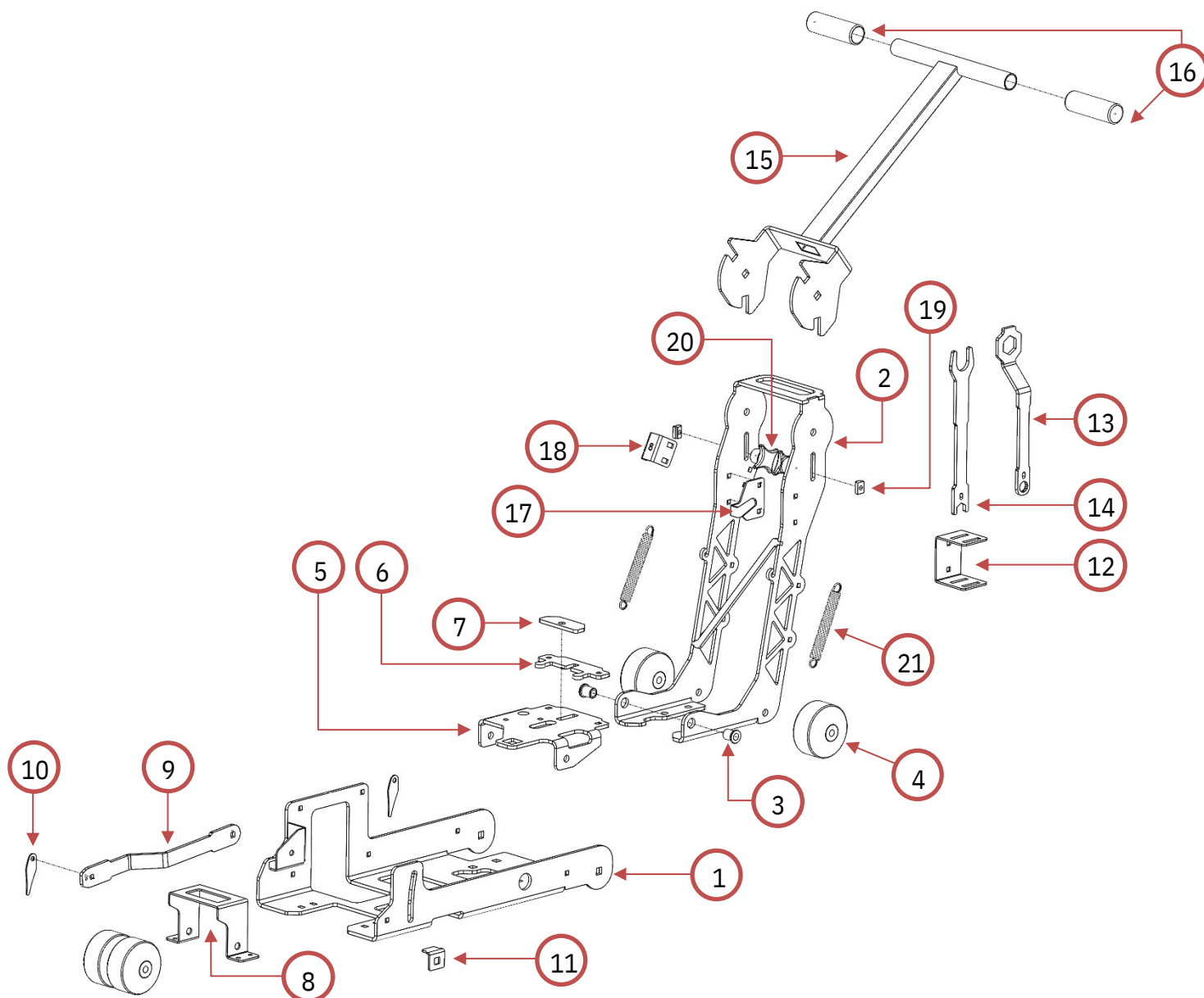

Part #	Description
8 - 1	Saw Base
8 - 2	Handle Mount
8 - 3	Powerhead Pivot Plate Bearing
8 - 4	Wheel
8 - 5	Powerhead Pivot Plate
8 - 6	Powerhead Plate Alignment
8 - 7	Powerhead Plate Lock
8 - 8	Front Wheel Mount
8 - 9	Pointer Arm
8 - 10	Pointer
8 - 11	Depth Stop
8 - 12	Wrench Holder
8 - 13	Nut Wrench

Part #	Description
8 - 14	Shaft Wrench
8 - 15	Handle
8 - 16	Grip
8 - 17	Blade Holder
8 - 18	Lift/Lower Lock
8 - 19	Position Lock Nut
8 - 20	4-arm Knob
8 - 21	Tension Spring

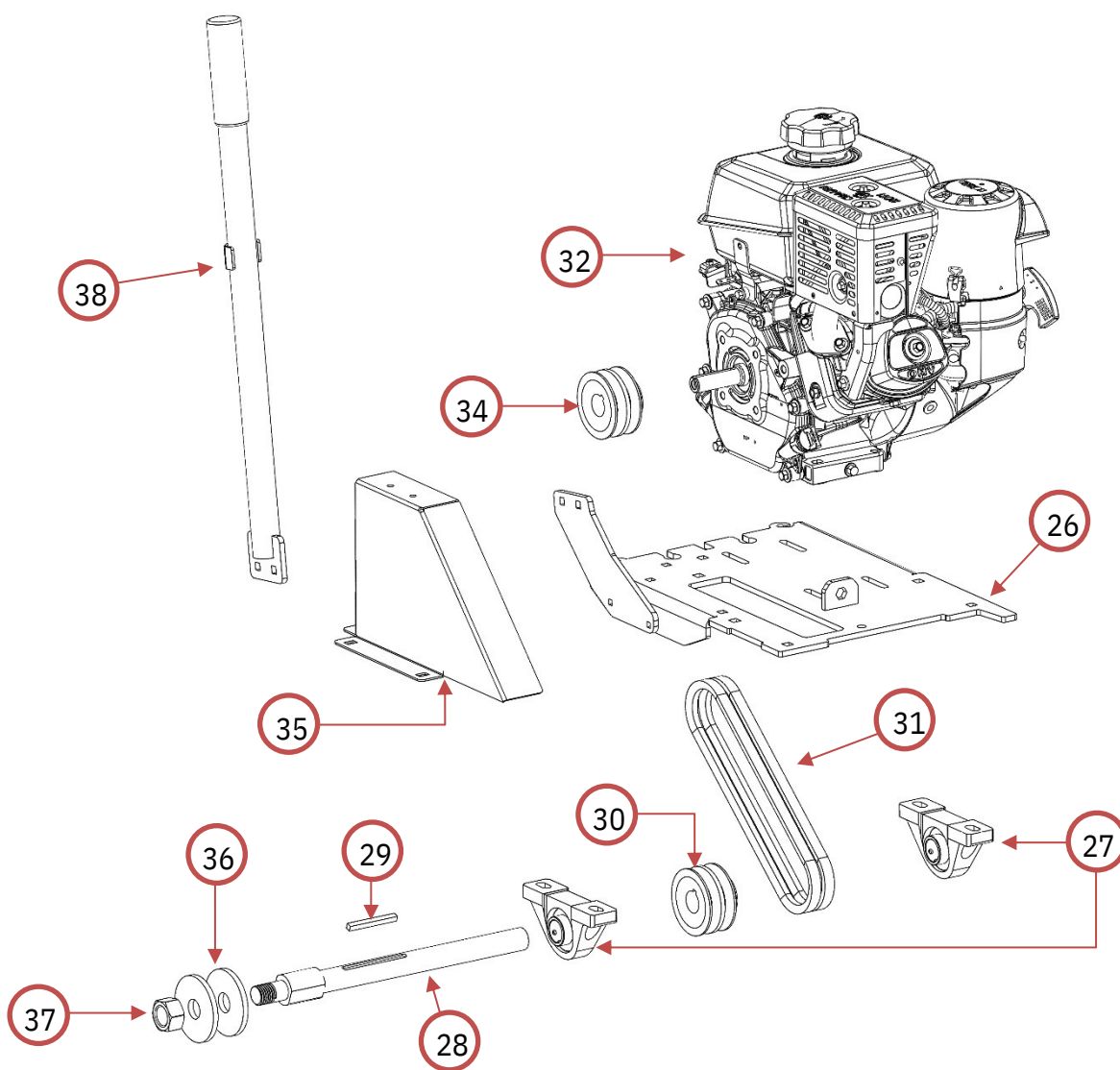

Part #	Description
8 - 26	Powerhead Mounting plate
8 - 27	Blade Shaft Bearing
8 - 28	Blade Shaft
8 - 29	Blade Shaft Key
8 - 30	Blade Shaft Pulley
8 - 31	Drive Belt
8 - 32	Motor
8 - 33	Motor Shaft Key
8 - 34	Motor Pulley
8 - 35	Belt Cover
8 - 36	Blade Clamp
8 - 37	Blade Shaft Nut
8 - 38	Lift/Lower Handle
8 - 40	Shaft Assembly (Part #: 27, 28, 29, 30, 36 & 37)
8 - 41	Blade Clamp Shim (Not Pictured)

GCT-8 Series III Early Entry Dust Box

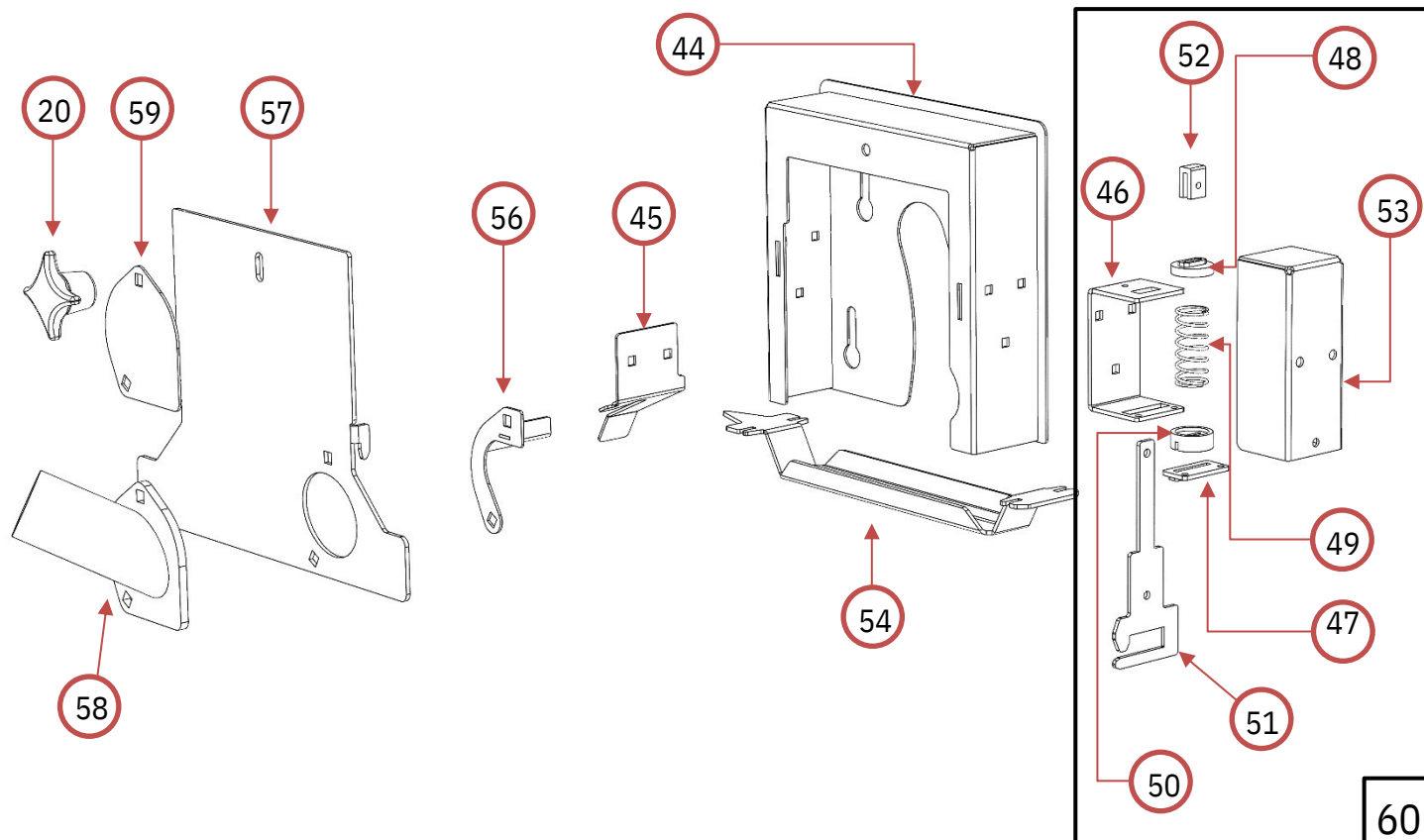

Part #	Description
8 - 44	Dust Box Main
8 - 45	Internal Dust Deflector
8 - 46	Spring Mount
8 - 47	Lower Slide
8 - 48	Upper Spring Retainer
8 - 49	Spring
8 - 50	Lower Spring Retainer
8 - 51	Skid Plate Slide
8 - 52	Slide Stop
8 - 53	Spring Cover
8 - 54	Skid Plate - 0.090 Opening
8 - 55	Skid Plate - 0.25 opening (Not Pictured)
8 - 56	Dust Box Door Baffle
8 - 57	8EE Dust Box Door
8 - 58	Dust port
8 - 59	Dust port Block Off
8 - 60	Skid Plate Slide Assembly
8 - 61	Early Entry Dust Box Assembly w/ Skid Plate

GCT-8 Series II Dust Box

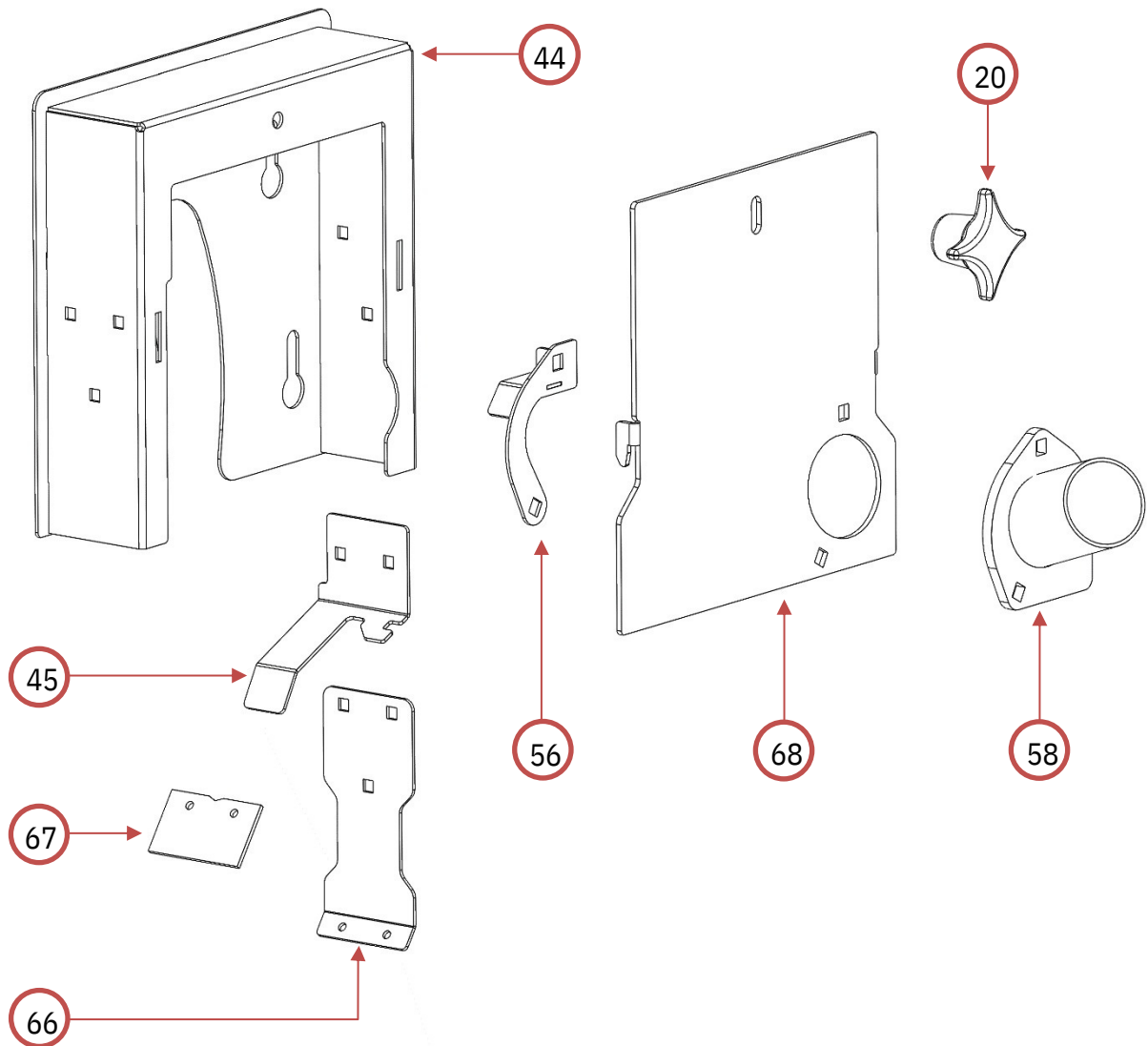

Part #	Description
8 - 66	Dust Skirt Mount
8 - 67	Dust Skirt
8 - 68	GCT-8 Series II Dust Box Door
8 - 69	GCT-8 Series II Dust Box Assembly

Product Set-Up

Warnings!

This Saw is made for outdoor use only

Follow the engine manufactures manual prior to saw set-up. These instructions are only intended to show you the set-up of our saw. Do not use until you have been trained on how to properly operate a walk behind concrete saw.



Stay clear of others while in operation. Debris can fly from blade area. Eye and face protection required.



Respirator required. Operate in well ventilated area.



Ear protection required.

Blade Removal and Installation

Ensure engine switch is in the off position

1. Remove the knob on the outside of the dust box, slide the blade guard upward, and pull away from the unit. (Fig. 1)
2. Loosen the nut on the blade shaft using the wrenches provided (Fig. 2). The flat wrench is used on the shaft between the dust box and the engine.
3. Place one washer on either side of the blade (Fig. 3). Ensure the blade is oriented for a counter-clockwise rotation.
4. Install all hardware and completely tighten.

Figure 1



Figure 2

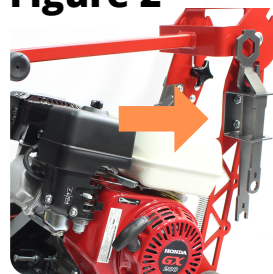
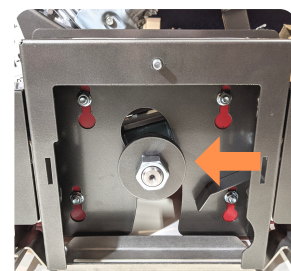

Figure 3



Blade Pointer Alignment

Install the blade before aligning pointers

1. Lower the pointer arm
2. Place a straight edge against the blade spanning from the rear pointer to the front pointer
3. Using a 1/2" wrench, loosen the pointer shown in Fig. 4 and align them with your straight edge.
4. Tighten all loose hardware.

Figure 4

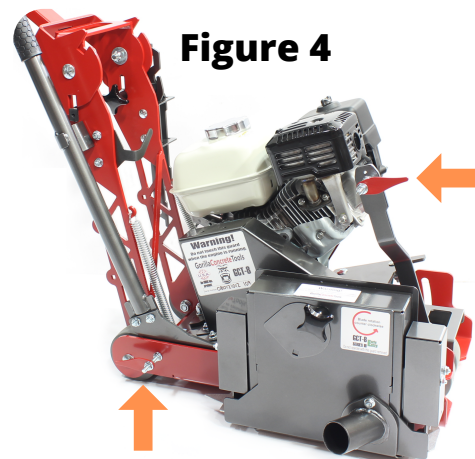

Blade Depth

The blade depth gauge features reference points with 1/4" or 1/2" depth increments up to 2" depth.

1. To adjust the depth, loosen the nut (Fig. 5) and slide up or down the slot.
2. Align bolt head with the arrow corresponding to the desired depth.
3. Tighten nut once desired depth is achieved.

Figure 5



Handle Positioning

1. To adjust the handle position, loosen the two black knobs on the handle (Fig. 6). Once loosened, slide the knobs downward.
2. Adjust the handle into either the operation position (Fig. 7) or the transport position (Fig. 8) using the slots on the handle.
3. Once the handle is in the desired position, slide the knob into the slot and tighten.

Figure 6

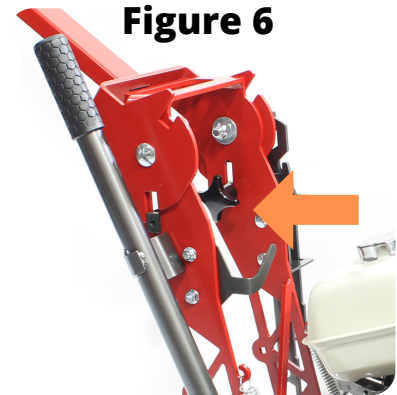

Figure 7



Figure 8



Skid Plate Pressure Adjustment (Fig. 9)

To access the bolts, follow the steps for blade removal

removal

1. Once you have access, loosen bolts and slide up or down to the desired position within the key-way. **The skid plate should remain in contact with the cutting surface in order to function properly**
2. Once the desired position is achieved, tighten all hardware and reinstall the blade and blade guard.

Figure 9

